

# BARRI

# 88

- Oil-hydraulic barrier
- For traffic control



**FADINI**<sup>®</sup>  
the gate opener

GB

## Oil-hydraulic traffic control barrier

Compact oil-hydraulic barrier fitted with anodized aluminium beam; suitable for commercial applications and for car parks where heavy duty open/close operations are required. Reliable and weatherproof; the housing is entirely made of sheet steel specially treated to provide a galvanized coating for a long lasting finish with epoxy paint in yellow colour. It is possible to reach the mechanism that operates the beam and the electronic control box through a lockable door with a coded key. The oil-hydraulic mechanism, ie. motor/pump/valve assembly is compact, capable of fast operations, smooth running and is fitted with a dampening device to slow down speed in both directions of movement. The beam is counterbalanced to perform regular, smooth movements without jerking. The beam in its horizontal position is supported by a folding pedestal or by a fixed post having a fork-shaped end. With both options it is possible to adjust the height from ground level by means of alignment adjustments, which also set the stop position of the motor pump through the limit switches with incorporated micro-switches. The electronics is located inside the housing.

If manual operation is required in event of a power failure, the barrier has an "emergency release" which is fitted to the by-pass valve assembly at the bottom of the oil reservoir of the motor pump unit. The angular speed of the beam is 4-5 seconds and is factory pre-set, therefore it is not possible to change it once installed. Barri 88 is designed as a handed unit. At the time of the order it is requested to specify right-hand or left-hand making reference to the position of the beam in relation to the door normally situated to



the inside of the property (see drawing at the back of the brochure). Barri 88 is produced in one speed version; the length of the beam is 4 m and can be cut to measure to meet the site requirements. It is entirely produced by Meccanica Fadini and undergoes continuous tests to control the manufacturing process and ensure a quality product.

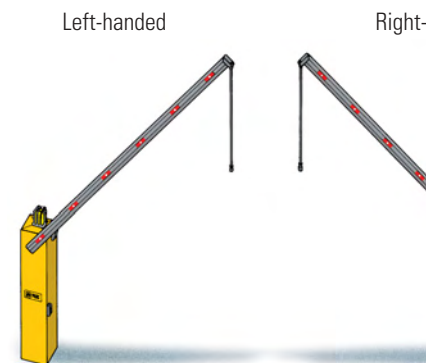
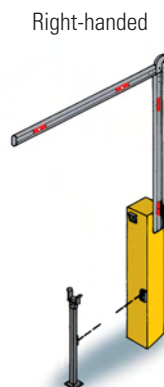
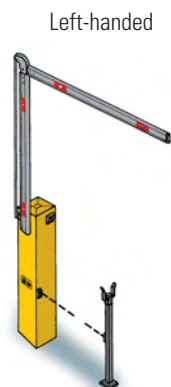



Ⓐ The electronic control box Elpro 88 exp can be raised for wiring operations.



Ⓐ

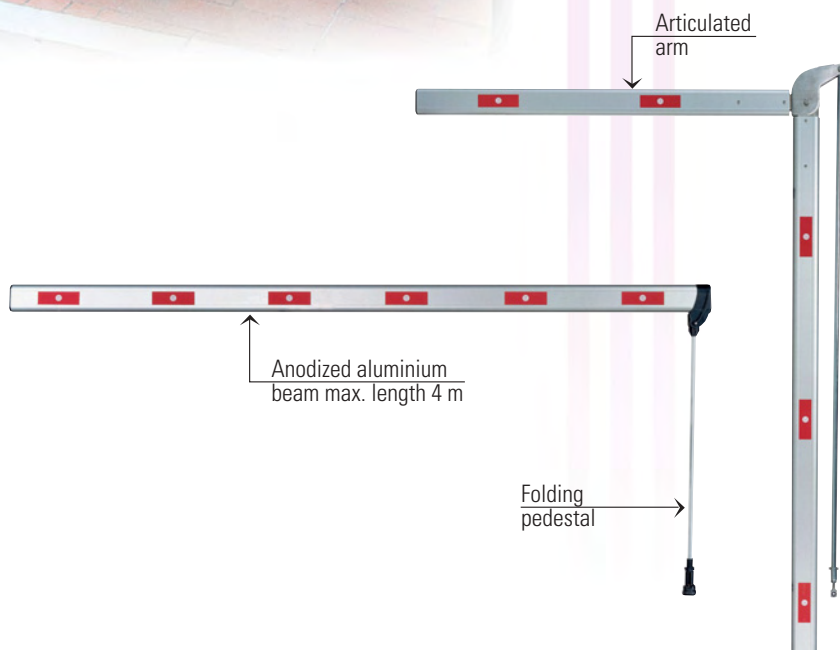

-handed

Left-handed

Right-handed



# BARRI 88 OIL-HYDRAULIC BARRIER

## Technical specifications

### OIL-HYDRAULIC PUMP

Pump flow rate P10.....	2.75 l/min.
Working pressure.....	2 MPa (20 bar)
Max. pressure.....	4 MPa (40 bar)
Working temperature.....	-20°C +80°C
Hydraulic oil.....	Oil FADINI A 15 by Agip
Max. shaft rotation.....	95°
Static weight.....	58 Kg
Rated torque.....	185.2 Nm
Aluminium beam.....	4 m
Opening time 4 m beam.....	5 s
Closing time 4 m beam.....	5 s
Protection standard.....	IP 557
Colour of the housing.....	RAL 1018 zinc-yellow

### ELECTRIC MOTOR

Power output.....	0.24 KW (0.33 HP)
Supply voltage / Frequency.....	230 V - 50 Hz
Absorbed power.....	330 W
Absorbed current.....	1.8 A
Capacitor.....	12.5 µF
Motor rotation speed.....	1'350 rev./min.
Intermittent service.....	S 3
Insulation class.....	F

### ELECTRONIC PROGRAMMER

Three relays. One for safety.....	24 V 16 A
Transformer.....	8 VA
Capacitor.....	12 µF 400 V

### SERVICE

Duty cycle.....	5 s Opening - 30 s Stop - 5 s Closing
Time of one complete cycle.....	40 s
No. of complete cycles "Opening - Stop - Closing".....	90/h
Cycles a year, 8 hours/service a day.....	N. 262'000

### WARNINGS

- Should the oil-hydraulic operator be removed from its place for maintenance, make sure that the hydraulic locking device is released, tighten the oil reservoir plug and remove the electric motor cables from their terminals in the control box.  
Switch off the mains to the system.
- Dispose properly of the packaging materials (such as cardboard, polystyrene, nylon).
- The whole apparatus must be properly earthed by means of the specifically provided screw.

Distributor's box

The manufacturers reserve the right to change the products without any previous notice

## Accessories



**ASTRO 43/2R** - plug in radio receiver card. 2 channels



**PRIT 19** Keyswitch



**MIRI 4** - flashing lamp



**BIRIO A8** aerial



**TRIFO 11** - infra-red modulated photocells



**ASTRO 43/2 TR** transmitter



High voltage safety cut off switch. CEI Standards



Fixing base plate



Fixed fork pedestal



Photocell Trifo 11 mounted to the anodized aluminium post with fixing base plate

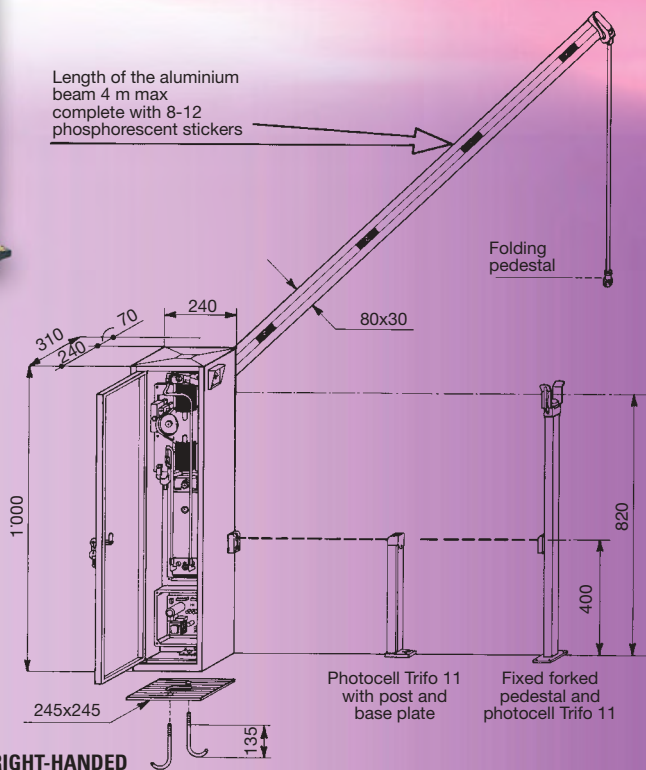

EUROPEAN MARK CERTIFYING CONFORMITY TO THE ESSENTIAL REQUIREMENTS OF THE STANDARDS 98/37/EC

- DECLARATION OF CONFORMITY
- SAFETY NORMS
- EN 12453, EN 12445 STANDARDS
- CEI EN 60204-1 STANDARDS
- WARRANTY CERTIFICATE ON THE CUSTOMER'S REQUEST

The "CE" mark certifies that the operator conforms to the essential requirements of the European Directive art. 10 EEC 73/23, in relation to the manufacturer's declaration for the supplied items, in compliance with the body of the regulations ISO 9000=UNI EN 29000. Automation in conformity to EN 12453, EN 12445 safety standards. The growth of MECCANICA FADINI has always been based on the development of guaranteed products thanks to our "TOTAL QUALITY CONTROL" system which ensures constant quality standards, updated knowledge of the European Standards and compliance with their requirements, in view of an ever increasing process of improvement.



AUTOMATIC GATE MANUFACTURERS

Via Mantova, 177/A - 37053 Cerea (Verona) Italy - Tel. +39 0442 330422 r.a. - Fax +39 0442 331054 - e-mail: info@fadini.net - www.fadini.net