

TOP-QUALITY
PNEUMATIC ACTUATOR

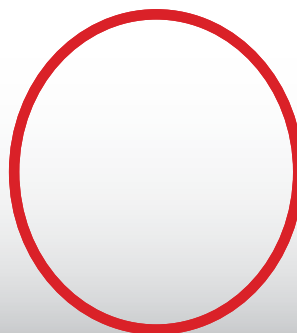

TOP-QUALITY

INNOBIZ
기술 혁신형 중소기업



INTRODUCTION

PDS series Pneumatic Actuators are designed using Scotch-Yoke technology from PDS 50 to the largest of PDS 200. Scotch-Yoke technology is well known to all users as the most suitable actuator mechanism for valve and damper operation as it produces higher torque at both end positions.

Specification of PDS actuators follow international standards for faster and easier mounting of accessories like Solenoid valves, limit switches, positioners etc.

Ranges available are 10Nm through 4000Nm double acting, and 5Nm through 1900Nm spring return.

The range of ambient temperature for standard operation is -20°C ~ 80°C as standard (For higher and lower temperature applications please consult manufacturer before placing order).

Mounting dimensions follow ISO5211, DIN3337, NAMUR, VDI/VDE3845 standards,

The drive shafts come in various sizes with double square shaped female bore for accommodating valve shaft, Spring package is pre-compressed for increased safety, Extremely long service life and reliable performance.

I-TORK Controls Ltd. also provides ITS series limit switch boxes (weather proof, explosion proof), solenoid valves, positioners for modulating services and other pneumatic accessories.

Side hand-wheel and de-clutchable gear box for manual operation are also options available in the I-TORK product range.

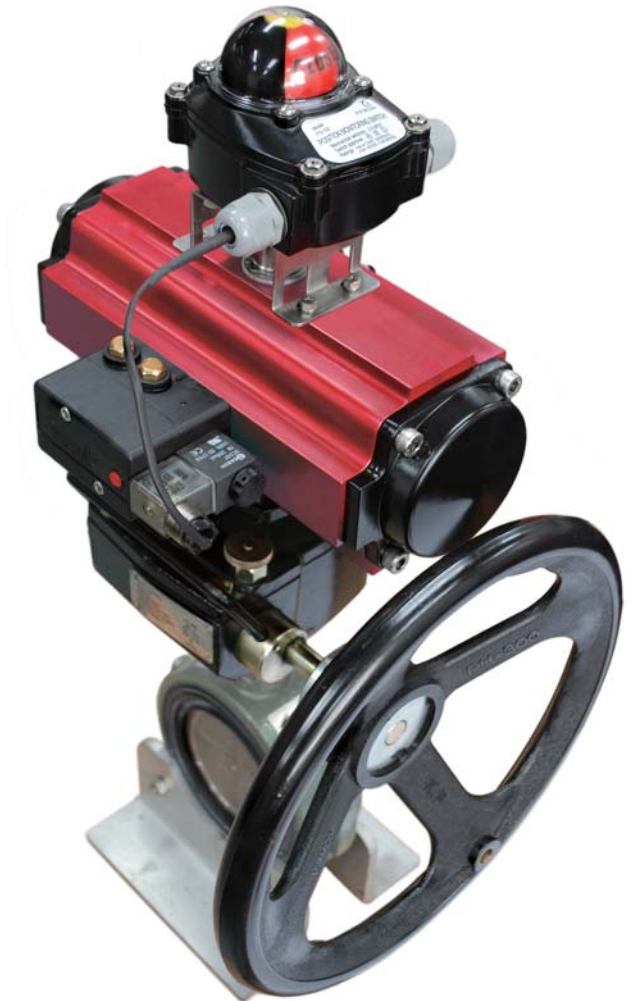

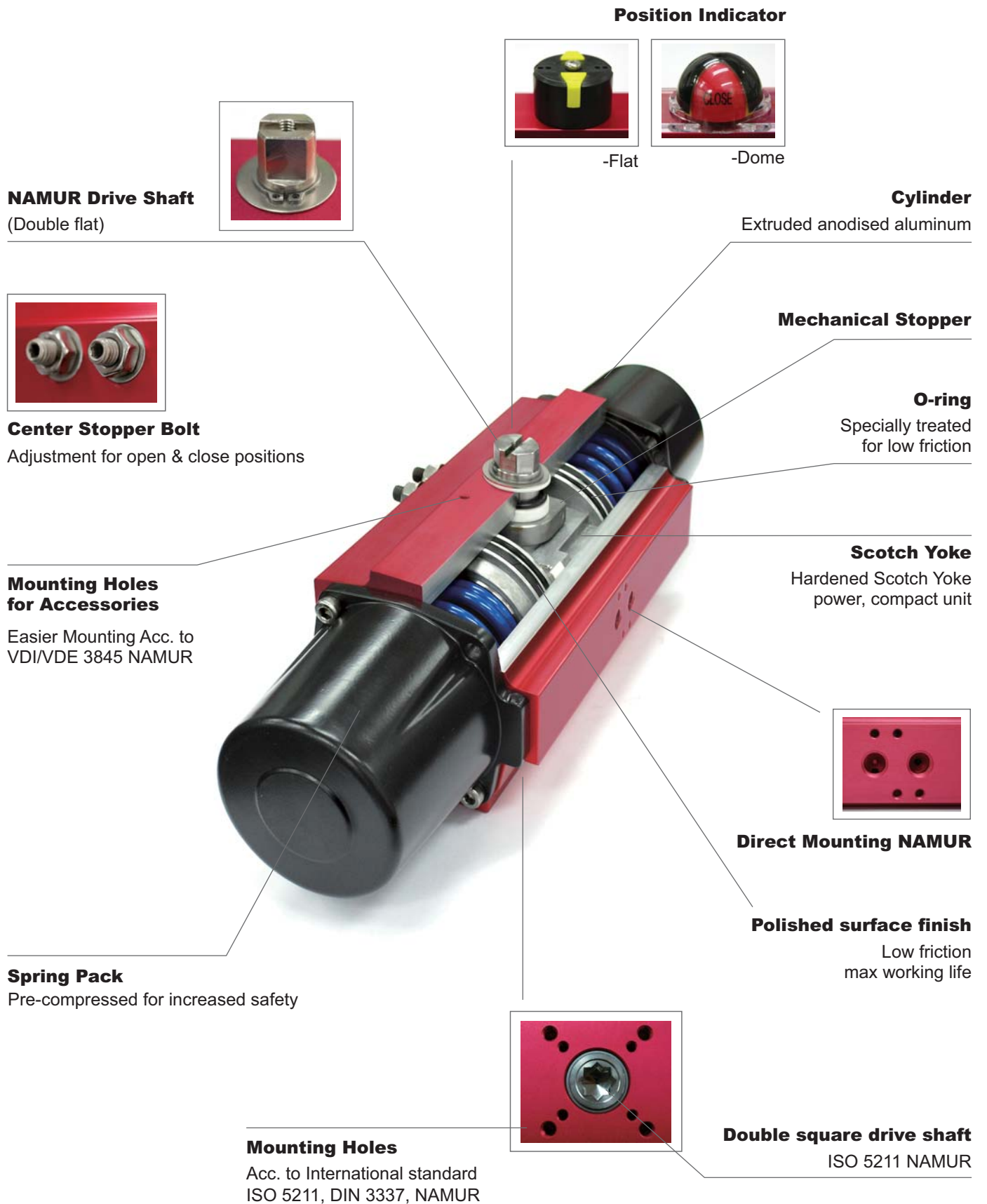

FEATURES AND ADVANTAGE



Advantage (Scotch Yoke)

The I-TORK actuators provide increased torque at open and close position, this closely matches the required torque for practical valve operation.

- Increased torque at the open and close position.
- Compact design and size
- Extremely long cyclic life
- Adjustable center stopper for both open & close positions

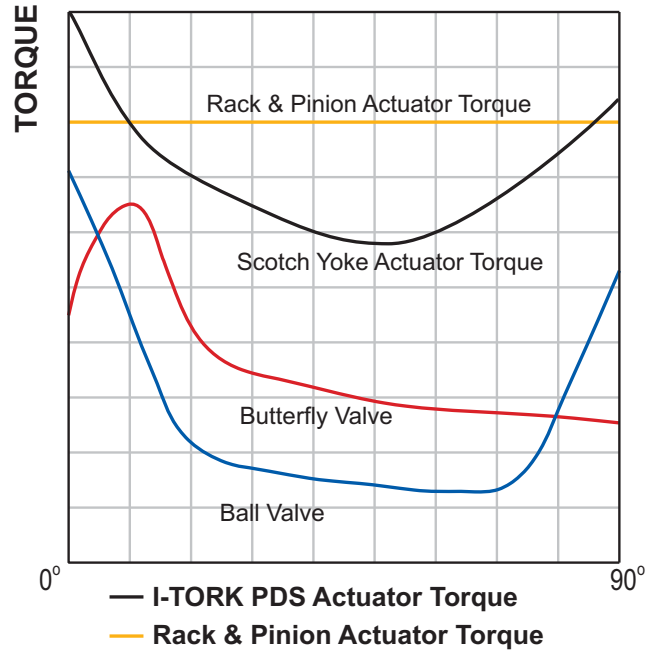

MECHANICAL MOVEMENT & POSITION INSIDE

DOUBLE ACTING

CLOSE

OPEN

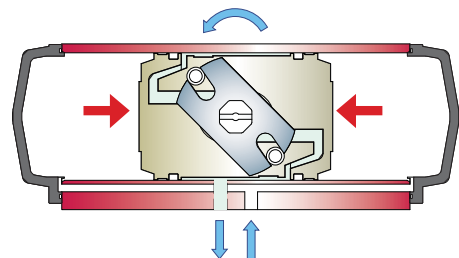
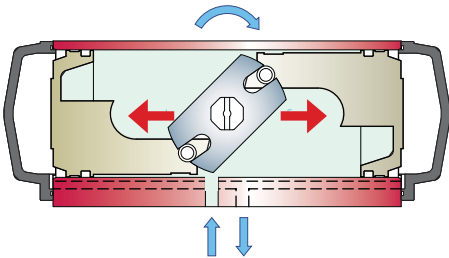

SPRING RETURN

CLOSE

OPEN

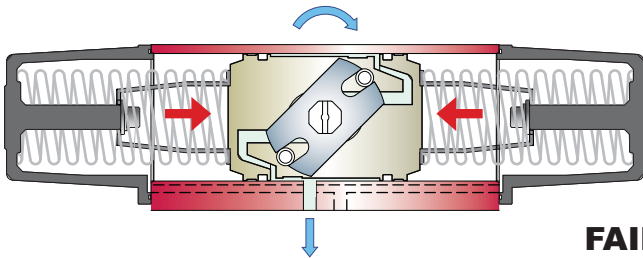

FAIL CLOSE

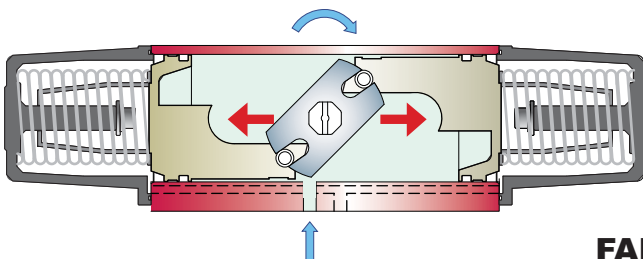
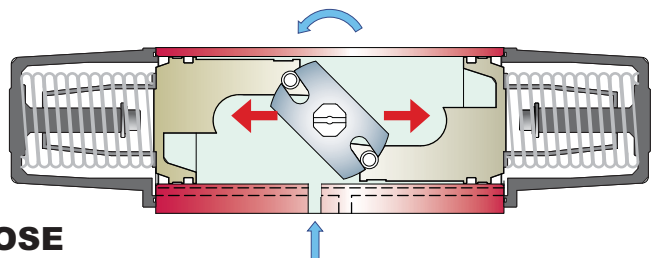

FAIL OPEN

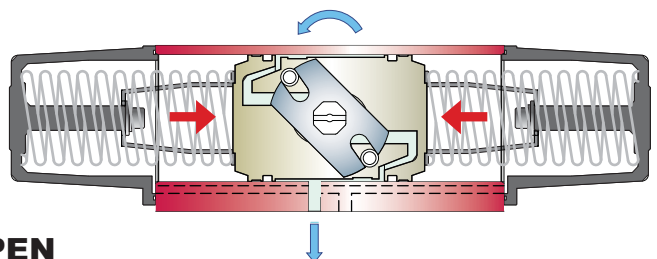

DOUBLE ACTING OUTPUT TORQUE (Nm)

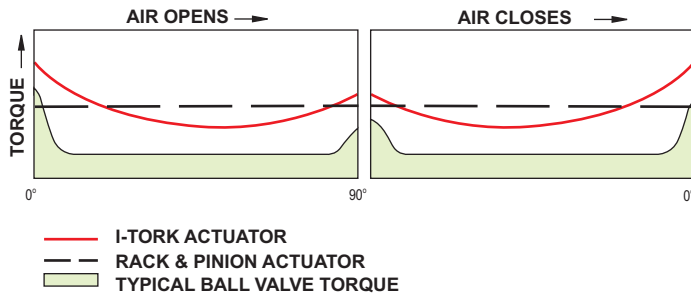

MODEL	Angle	2.8 bar 40 psi	3.5 bar 50 psi	4.2 bar 61 psi	5.5 bar 80 psi	6 bar 87 psi	7 bar 100 psi	8 bar 116 psi	Air Consumption (L, at 5.5 bar)		Operating Time (Sec., at 5.5bar)
									OPEN	CLOSE	
PD50	0°	27	34	41	54	59	69	79	0.16	0.16	< 0.3
	45°	12	15	17	23	25	29	33			
	90°	19	24	29	38	42	48	55			
PD70	0°	76	95	114	149	163	190	217	0.46	0.46	< 0.6
	45°	32	40	48	62	68	79	90			
	90°	53	66	78	104	114	133	152			
PD85	0°	141	176	212	277	302	353	403	0.8	0.8	< 1.0
	45°	59	74	89	116	127	148	169			
	90°	99	123	148	194	212	247	282			
PD100	0°	229	286	343	449	490	571	653	1.32	1.28	< 2.0
	45°	96	120	144	188	205	239	273			
	90°	160	200	240	314	343	400	457			
PD125	0°	438	547	657	860	938	1,095	1,250	2.49	2.42	< 3.0
	45°	182	228	273	358	390	456	521			
	90°	306	383	460	602	657	766	876			
PD140	0°	583	729	890	1,167	1,269	1,459	1,692	2.82	3.11	< 4.0
	45°	241	301	368	482	524	602	698			
	90°	448	560	684	897	976	1,122	1,300			
PD160	0°	850	1,062	1,274	1,668	1,820	2,124	2,427	4.52	4.61	< 5.0
	45°	355	444	533	698	761	888	1,015			
	90°	595	744	892	1,168	1,275	1,487	1,700			
PD200	0°	1,622	2,028	2,433	3,187	3,476	4,056	4,635	9.07	9.21	< 6.0
	45°	679	848	1,018	1,333	1,454	1,697	1,939			
	90°	1,136	1,420	1,704	2,231	2,434	2,840	3,245			

*Please be sure to include appropriate torque safety factors and consider variable service conditions when sizing.

TECHNICAL INFORMATION

SPRING RETURN OUTPUT TORQUE (Nm)

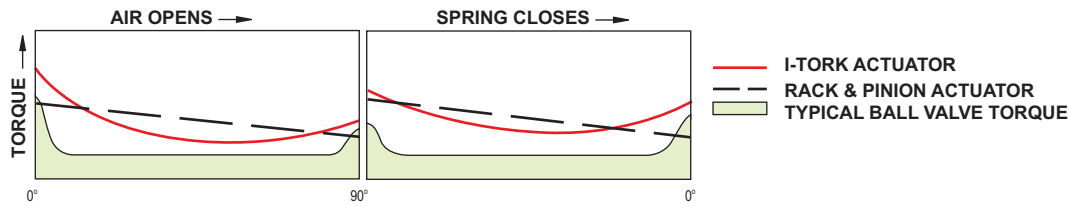

Spring Close

MODEL	Function	Angle	4.2 bar 60 psi	5.5 bar 80 psi	6 bar 87 psi	7 bar 100 psi	Air Consumption (L, at 5.5 bar)	Operating Time (Sec., at 5.5bar)
PS50	Air to open	0°	25.6	34.6	37.6	42.5	0.16	< 0.3
		55°	8.3	11.1	12.0	13.4		
		90°	10.0	13.1	14.2	15.4		
	Spring to close	90°	18.6	25.0	27.3	32.2		
		35°	9.0	12.0	13.1	15.5		
		0°	15.2	19.9	21.7	25.6		
PS70	Air to open	0°	68.3	92.3	98.9	112.3	0.46	< 0.6
		55°	21.9	29.0	31.6	35.4		
		90°	29.0	38.0	41.7	46.2		
	Spring to close	90°	49.5	66.7	72.1	84.6		
		35°	25.7	34.3	37.4	43.8		
		0°	43.8	57.2	63.6	74.6		
PS85	Air to open	0°	131.9	176.2	187.9	216.7	0.79	< 1.0
		55°	40.1	53.4	57.9	66.9		
		90°	50.4	67.0	72.5	83.9		
	Spring to close	90°	95.7	127.8	139.3	159.5		
		35°	48.4	64.5	70.4	80.6		
		0°	76.7	101.9	114.6	131.0		
PS100	Air to open	0°	214.6	286.8	311.2	359.6	1.28	< 2.0
		55°	64.7	86.1	93.4	108.4		
		90°	80.5	106.7	115.7	134.9		
	Spring to close	90°	156.0	208.7	227.2	259.2		
		35°	78.6	104.9	114.3	130.3		
		0°	123.2	163.5	178.5	203.3		
PS125	Air to open	0°	412.5	552.4	601.3	689.3	2.42	< 3.0
		55°	115.9	164.9	189.4	217.2		
		90°	132.3	202.8	247.1	283.4		
	Spring to close	90°	320.7	401.1	409.7	471.5		
		35°	158.4	200.9	208.4	240.0		
		0°	234.2	309.8	336.4	388.5		
PS140	Air to open	0°	565.6	683.5	-	-	3.11	< 4.0
		55°	176.7	200.4	-	-		
		90°	235.8	249.8	-	-		
	Spring to close	90°	387.4	567.6	-	-		
		35°	184.7	287.1	-	-		
		0°	324.5	483.9	-	-		
PS160	Air to open	0°	802.5	1,075.6	1,189.6	1,373.0	4.61	< 5.0
		55°	239.6	319.5	341.8	395.8		
		90°	294.8	390.9	401.8	467.1		
	Spring to close	90°	584.0	780.8	872.5	997.6		
		35°	292.7	390.2	429.9	491.3		
		0°	452.6	579.9	630.3	718.8		
PS200	Air to open	0°	1,561.3	2,079.9	2,272.7	2,603.4	9.21	< 6.0
		55°	452.2	607.9	660.3	747.3		
		90°	536.6	729.5	786.7	877.1		
	Spring to close	90°	1,141.7	1,508.2	1,646.9	1,920.1		
		35°	564.3	747.4	813.6	946.8		
		0°	835.6	1,115.9	1,202.8	1,391.4		

*Please be sure to include appropriate torque safety factors and consider variable service conditions when sizing.

SPRING RETURN OUTPUT TORQUE (Nm)

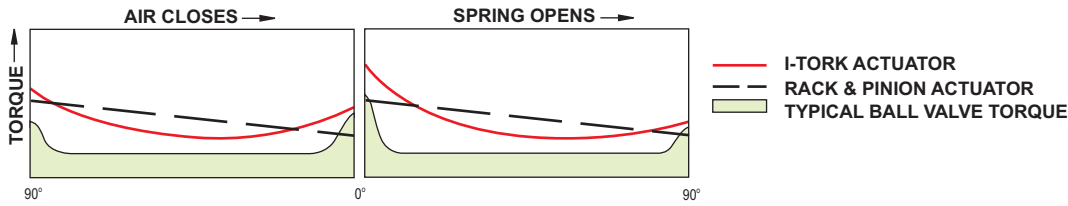

Spring Open

MODEL	Function	Angle	4.2 bar 60 psi	5.5 bar 80 psi	6 bar 87 psi	7 bar 100 psi	Air Consumption (L, at 5.5 bar)	Operating Time (Sec., at 5.5bar)
PS50	Air to close	90°	17.9	24.2	26.3	29.8	0.16	< 0.3
		55°	8.3	11.1	12.0	13.4		
		0°	14.3	18.7	20.3	22.0		
	Spring to open	0°	26.5	35.7	39.0	46.1		
		35°	8.3	11.0	12.0	14.1		
		90°	10.7	13.9	15.2	17.9		
PS70	Air to close	90°	47.8	64.6	69.3	78.6	0.46	< 0.6
		55°	22.7	30.4	32.8	36.9		
		0°	41.4	54.2	59.6	66.0		
	Spring to open	0°	70.7	95.3	103.0	120.8		
		35°	22.9	30.3	33.3	39.0		
		90°	30.7	40.1	44.6	52.2		
PS85	Air to close	90°	92.4	123.4	131.6	151.7	0.8	< 1.0
		55°	42.3	56.4	61.2	70.6		
		0°	72.0	95.6	103.5	119.8		
	Spring to open	0°	136.6	182.5	199.0	227.8		
		35°	42.1	56.1	61.2	70.0		
		90°	53.7	71.4	80.2	91.7		
PS100	Air to close	90°	150.3	200.8	217.9	251.8	1.32	< 2.0
		55°	68.5	91.3	99.1	114.8		
		0°	114.9	152.3	165.3	192.7		
	Spring to open	0°	222.8	298.0	324.4	370.2		
		35°	68.2	90.9	99.0	112.9		
		90°	86.2	114.5	125.0	142.4		
PS125	Air to close	90°	288.8	386.8	421.0	482.6	2.49	< 3.0
		55°	125.6	175.2	191.1	219.1		
		0°	188.9	289.7	352.9	404.8		
	Spring to open	0°	458.0	572.9	585.1	673.4		
		35°	135.1	173.5	189.4	218.3		
		90°	164.0	217.0	235.6	272.1		
PS140	Air to close	90°	396.0	478.6	-	-	3.11	< 4.0
		55°	189.8	234.0	-	-		
		0°	336.8	356.7	-	-		
	Spring to open	0°	553.3	810.7	-	-		
		35°	171.6	253.6	-	-		
		90°	227.3	338.8	-	-		
PS160	Air to close	90°	561.9	753.1	832.9	961.4	4.52	< 5.0
		55°	254.5	339.9	367.7	425.3		
		0°	421.0	558.3	573.8	667.0		
	Spring to open	0°	834.1	1115.1	1246.1	1424.8		
		35°	255.9	340.6	372.4	425.4		
		90°	316.9	418.6	441.4	503.3		
PS200	Air to close	90°	1093.2	1456.4	1591.3	1822.9	9.07	< 6.0
		55°	485.1	650.2	707.6	804.1		
		0°	766.4	1041.9	1123.5	1252.7		
	Spring to open	0°	1630.5	2154.0	2352.0	2742.2		
		35°	481.5	639.3	693.9	806.1		
		90°	585.1	781.4	842.2	974.3		

*Please be sure to include appropriate safety factors and consider various service conditions when sizing.

DIMENSIONS

DOUBLE ACTING : PD Series

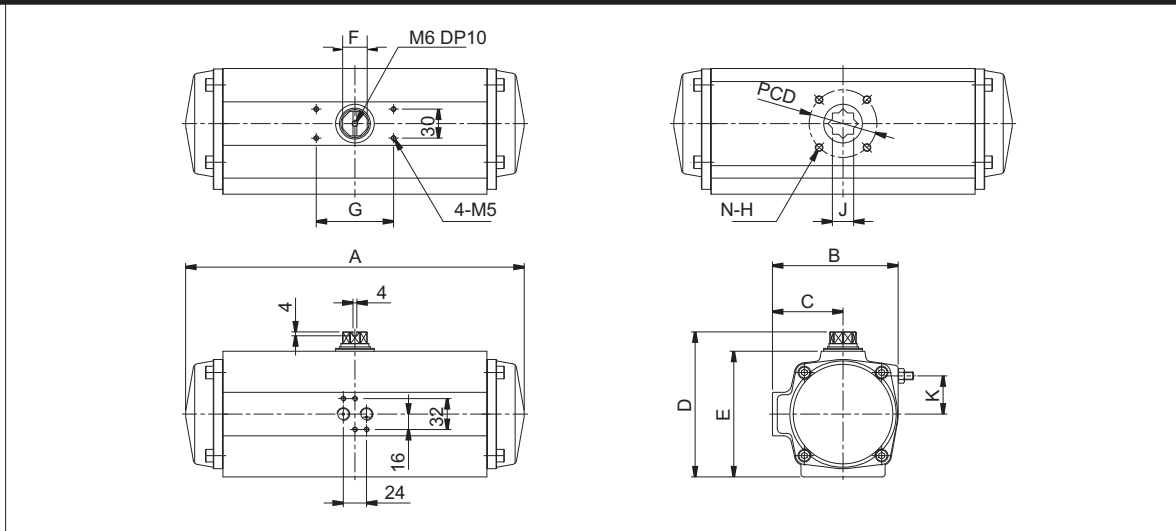

UNIT : mm

MODEL	A	B	C	D	E	F	G	ISO5211	PCD	N-H	J	DP	K	WEIGHT(kg)
PD50	186	73	42	91	71	9	80	F03/F05/F07	35/50/70	4-M5/M6	11x11	15	19.5	1.6
PD70	255	96	55	112	92	14	80	F05/F07	50/70	4-M6/M8	17x17	20	26	3
PD85	300	110	62	130	110	18	80	F05/F07	50/70	4-M6/M8	17x17	25	33	5.4
PD100	350	130	73	150	130	20	80	F07/F10	70/102	4-M8/M10	22x22	30	39.5	7.9
PD125	422	159	88	182	162	22	80/130	F10/F12	102/125	4-M10/M12	27x27	35	47.5	11.5
PD140	435	166.5	91.5	210	180	28	80/130	F10/F12	102/125	4-M10/M12	27x27	35	57	18.6
PD160	510	195	105	240	210	33	80/130	F10/F14	102/140	4-M10/M16	36x36	50	62	29
PD200	615	243	130	292	262	40	80/130	F12/F16	125/165	4-M12/M20	46x46	60	77.5	56

SPRING RETURN : PS Series

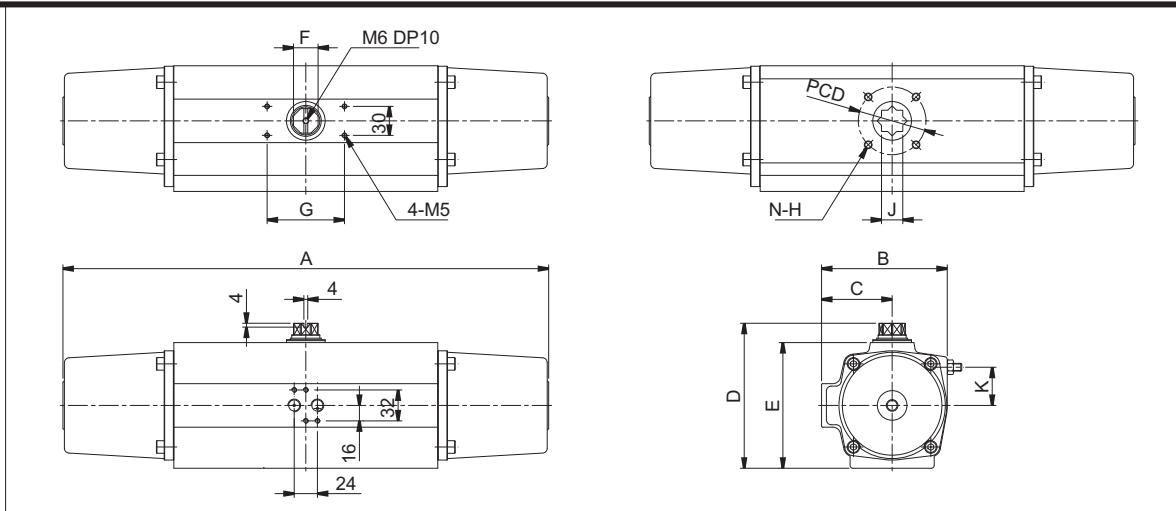

UNIT : mm

MODEL	A	B	C	D	E	F	G	ISO5211	PCD	N-H	J	DP	K	WEIGHT(kg)
PS50	255	73	42	91	71	9	80	F03/F05/F07	35/50/70	4-M5/M6	11x11	15	19.5	2
PS70	330	96	55	112	92	14	80	F05/F07	50/70	4-M6/M8	17x17	20	26	4.1
PS85	423	110	62	130	110	18	80	F05/F07	50/70	4-M6/M8	17x17	25	33	7.3
PS100	499	130	73	150	130	20	80	F07/F10	70/102	4-M8/M10	22x22	30	39.5	11.6
PS125	629	159	88	182	162	22	80/130	F10/F12	102/125	4-M10/M12	27x27	35	47.5	19
PS140	683	166.5	91.5	210	180	28	80/130	F10/F12	102/125	4-M10/M12	27x27	35	57	27
PS160	744	195	105	240	210	33	80/130	F10/F14	102/140	4-M10/M16	36x36	50	62	43.2
PS200	869	243	130	292	262	40	80/130	F12/F16	125/165	4-M12/M20	46x46	60	77.5	81.7

EXPLODED VIEW

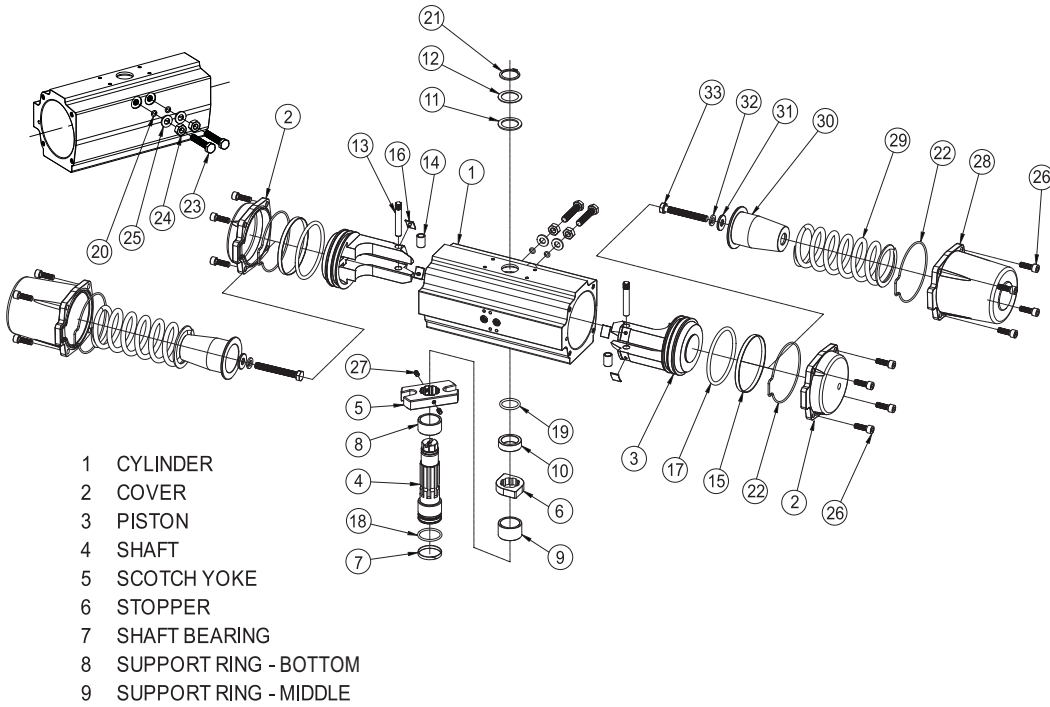

- 1 CYLINDER
- 2 COVER
- 3 PISTON
- 4 SHAFT
- 5 SCOTCH YOKE
- 6 STOPPER
- 7 SHAFT BEARING
- 8 SUPPORT RING - BOTTOM
- 9 SUPPORT RING - MIDDLE

- 10 SUPPORT RING - TOP
- 11 THRUST WASHER
- 12 WASHER - SHAFT
- 13 ROLLER PIN
- 14 ROLLER
- 15 SUPPORT BAND
- 16 PISTON GUIDE PAD
- 17 O-RING - PISTON
- 18 O-RING - SHAFT, LOWER
- 19 O-RING - SHAFT, UPPER
- 20 O-RING - STOPPER
- 21 SNAP RING
- 22 O-RING - COVER
- 23 ADJUST BOLT
- 24 ADJUST NUT
- 25 WASHER-STOPPER
- 26 HEX.HEAD SOCKET BOLT
- 27 SET SCREW
- 28 SPRING RETURN COVER
- 29 SPRING
- 30 SPRING RETAINER
- 31 PLANE WASHER
- 32 SPRING WASHER
- 33 TENSION SETTING BOLT

PD40 (RACK & PINION)

OUTPUT TORQUE

PD40 : DOUBLE ACTING (bar, N-m)

PRESSURE	2.8	3.5	4.2	5.5	6	7	8
TORQUE	5.6	7	8.4	11	12	14	16

Please be sure to include appropriate safety factors and consider various service conditions when sizing.

AIR CONSUMPTION (L, at 5.5 bar)	OPERATING TIME (Sec., at 5.5bar)
0.04	< 0.3

Air Volume :
0.04 Liter

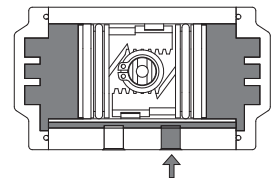

Air Volume :
0.04 Liter

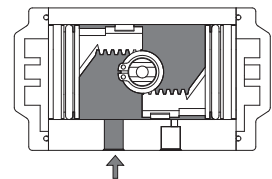

DIMENSIONS

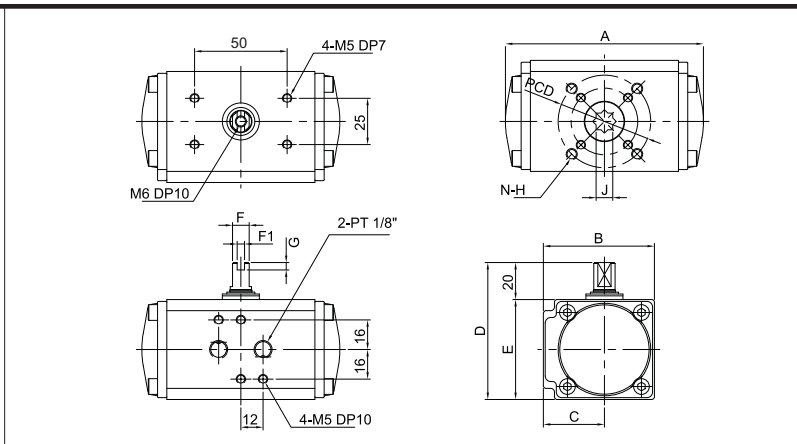

UNIT : mm

MODEL	A	B	C	D	E	F	F1	G	ISO5211	PCD	N-H	J	DP	WEIGHT(kg)
PD 40/ PS 40	107	60	33	74	54	9	4	4	F03/F05	35/50	4-M5/M6	9x9	11	1.1

EXPLODED VIEW

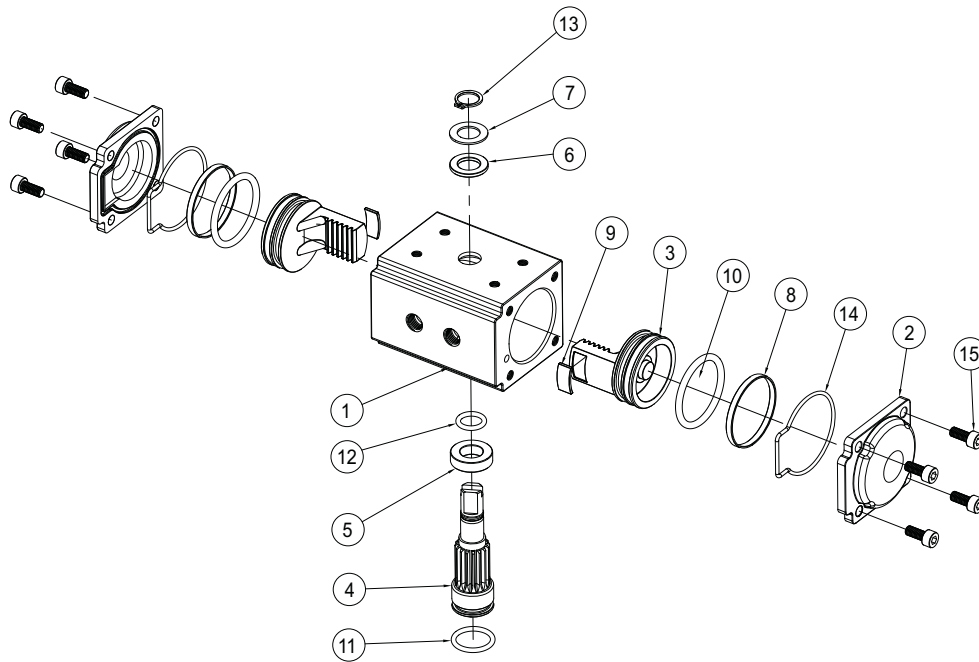

- 1 CYLINDER
- 2 COVER
- 3 PISTON
- 4 SHAFT
- 5 SUPPORT RING-UPPER
- 6 THRUST WASHER
- 7 WASHER - SHAFT
- 8 SUPPORT BAND
- 9 PISTON GUIDE PAD
- 10 O-RING - PISTON
- 11 O-RING - SHAFT, LOWER
- 12 O-RING - SHAFT, UPPER
- 13 SNAP RING
- 14 O-RING - COVER
- 15 STAINLESS WRENCH BOLT

ACCESSORIES

ITS Series Position Monitoring Switch Box

ITS 100 Series (Weather Proof)



SPECIFICATION	STANDARD OPTION
Enclosure	Weather proof IP67, O-ring sealed
Outside coating	Epoxy-Polyester inside and outside
Ambient temperature	-20°C ~ +80°C
Cable entries	2 - PT1/2", other standard threads
Terminal block	8 nos of terminal strips
Position indicator	Dome type 0°~90°
Mounting bracket	Stainless steel acc. to VDI/VDE 3845, NAMUR, SS1, SS2 as standard
Switches(Sensors)	2-SPDT mechanical switch(Form C)

ITS 300 Series (Explosion Proof)

Suitable for valves and actuators in hazardous area applications conforms to EN50014 and 50018, also suitable in Zone 1 and 2

Ex d : IECEx, GOST_R/RTN certified



SPECIFICATION	STANDARD OPTION
Enclosure	Explosion proof Ex d IIC T6, IP67, O-ring sealed
Outside coating	Epoxy-Polyester outside against corrosion
Ambient temperature	-20°C ~ +60°C
Cable entries	2 - PF3/4", other standard threads
Terminal block	8 nos of terminal strips
Position indicator	Dome type 0°~90°
Mounting bracket	Stainless steel acc. to VDI/VDE 3845, NAMUR, SS1, SS2 as standard
Switches(Sensors)	2-SPDT mechanical switch(Form C)

ITS 500 Series

Special stainless steel housig (316L or Duplex) for extremely corrosive environmental conditions & for off-shore applications.

Other specifications are shared with the ITS 300 series except for enclosure & coating.

Ex d : IECEx, GOST_R/RTN certified



Electro-Pneumatic Positioner



EPL (Linear Type)



EPR (Rotary Type)

EPL / EPR (Mechanical Type)

FEATURES

- Precise calibration with simple SPAN and ZERO adjustments
- Simple conversion to direct acting or reverse acting
- 1/2 split range available
- Rugged aluminum housing with corrosion-resistant coating
- Stainless steel gauges standard
- Restricted pilot valve orifice kit for small actuators included

*Options available

- Position transmitter (4-20mA output signal)
- Two limit switches (open and close)

SSL / SSR (Electronic Smart Type)

FEATURES

- Auto-calibration for optimum conditions
- Easy operation with four key pads and full text graphical LCD
- Single and double acting actuators
- Pressure regulator built in to eliminate variations in supply air pressure
- Economical energy saving
- Mounting on linear actuators according to IEC 534
- Mounting on rotary actuators according to VDI / VDE 3845

*Options available

- Position transmitter (4-20mA output signal)
- Gauge block with two stainless pressure gauges
- Explosion proof type (Ex d IIB T6, Exia IIC T6)
- HART communication (FSK)



SSL (Linear Type)



SSR (Rotary Type)



IPC

IPC (I/P CONVERTER)

FEATURES

- Pressure regulator built in to eliminate variations in supply air pressure
- Low air consumption due to piezo electric micro-valve
- Explosion proof type (please contact for details)

Solenoid Valve

- Robust, reliable patented 2 piston / 4 pillar poppet valve design provides bubble-tight shut-off for millions of cycles
- 5/2 function or 3/2 function selectable via 180o turn of the patented rotary sealing plate
- Direct NAMUR standard mounting
- Corrosion and impact resistant glass fiber reinforced composite material
- Low maintenance through non lubrication design
- High air flow (Cv > 1,1) and fast response
- Wide operating temperature range : -40°C to 50°C (-40°F to 125°F)
- Pressure range 2.5 - 8 Bar (35-120 PSI)

Weatherproof IP67

NEMA types 1, 2, 3, 3S, 4 and 4X & CE Certified

- ATEX Ex Series
- Ex-Proof Series
- Intrinsically Safe Series
- Standard Series

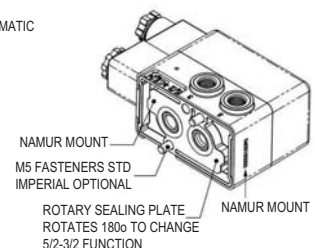
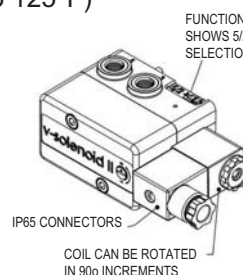

ACCESSORIES

Declutchable Gear Box

-Aluminum Housing

MODEL NO	ITG 050	ITG 070	ITG 140
Max. Output Torque	300 Nm	360 Nm	1310 Nm
Pneumatic Actuator Mounting Flange (ISO 5211)	F05 / F07	F07 / F10	F10 / F12
Valve Mounting Flange (ISO 5211)	F05 / F07	F07 / F10	F10 / F12
Reduction Ratio	40 : 1	38 : 1	50 : 1
Number of Turns 90°	10 Turn	9.5 Turn	12.5 Turn
Handwheel Diameter	Ø200	Ø200	Ø400
Weight	2.3 Kg	3.5 Kg	12.5 Kg
Application for Pneumatic Actuator	PS50 / 70 / 85 PD50 / 70	PS100 PD85	PS125 / 160 PD100 / 125

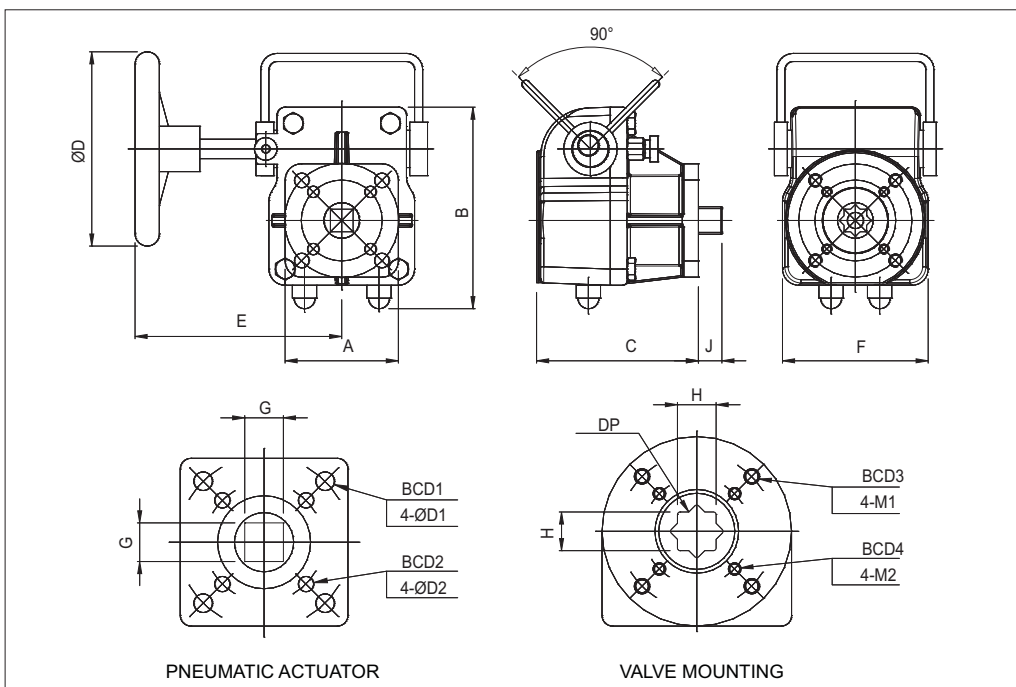

* Details are provided upon request.

Manual Handwheel



-For PDS50 to PDS200, DA and SR
-Simple and Compact in size and weight

* The details of this catalog are subject to change without prior notification.