

Category 4, EN 954-1

PNOZ X2, PNOZ X2.1, PNOZ X2.2



Emergency stop relay and safety gate monitor in accordance with VDE 0113-1 Part 1, 11/98 and EN 60204-1, 12/97.

Features

- Dual-channel operation which detects shorts across the input contacts
- Supply voltage: 24 VAC/DC
- PNOZ X2: monitored manual reset only
- PNOZ X2.2: several units may be started in parallel using one reset button

Approvals

	PNOZ X2/X2.1/X2.2
	●
	●
	●

Technical Details	PNOZ X2, PNOZ X2.1, PNOZ X2.2
Electrical Data	
Supply Voltage	AC: 24 V DC: 24 V
Tolerance	85 ... 110 %
Power Consumption	Approx. 2 W/2 VA
Voltage and Current at the Input and Reset Circuits and Feedback Control Loop	24 VDC/25 mA
Switching Capability in accordance with EN 60947-4-1, 10/91	AC1: 240 V/6 A/1500 VA DC1: 24 V/4 A/100 W
EN 60947-5-1, 10/91 (DC13: 6 cycles/min.)	AC15: 230 V/5 A; DC13: 24 V/4A
Output Contacts	2 safety contacts (N/O)
EN 954-1, 07/96, category 4	
Contact Fuse Protection (EN 60947-5-1, 10/91)	6 A quick or 4 A slow
Times	
Delay-on Energisation	Automatic reset: max. 150 ms Manual reset: max. 100 ms
Delay-on De-energisation	Single-channel input circuit: max. 120 ms Dual-channel input circuit: max. 30 ms
Recovery Time	Approx. 1 s
Simultaneity channel 1/2	∞
Max. Supply Interruption before De-energisation	Approx. 10 ms
Mechanical Data	
Maximum Cross Section of External Conductors	2 x 1.5 mm ² or 1 x 2.5 mm ² Single-core or multi-core with crimp connectors
Dimensions (H x W x D)	87 x 22.5 x 122 mm
Weight	220 g

Description

- 22.5 mm, S-95 housing, DIN-Rail mounting
- Positive-guided relay outputs: 2 safety contacts (N/O)
- Connections for
 - E-STOP button or safety gate limit switch
 - reset button
- Detects shorts across the input contacts
- LEDs for channel 1, channel 2 and power
- Increase in the number of safety contacts available by connecting expander modules.

- PNOZ X2.1 only: automatic reset
- PNOZ X2.2 only: as the PNOZ X2 but any number of units can be connected in parallel to one or more reset buttons

Operating Modes

- Single-channel operation
- Dual-channel operation
- Manual reset
- PNOZ X2 only: monitored manual reset

Category 4, EN 954-1

PNOZ X2, PNOZ X2.1, PNOZ X2.2

Internal Wiring Diagram

- PNOZ X2, PNOZ X2.1

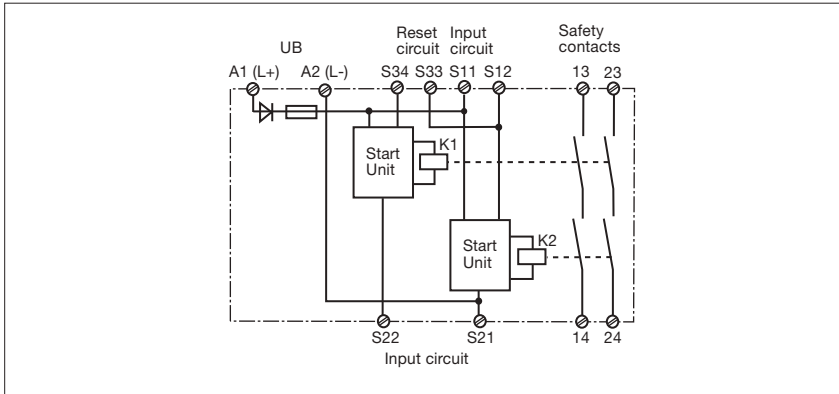

- PNOZ X2.2

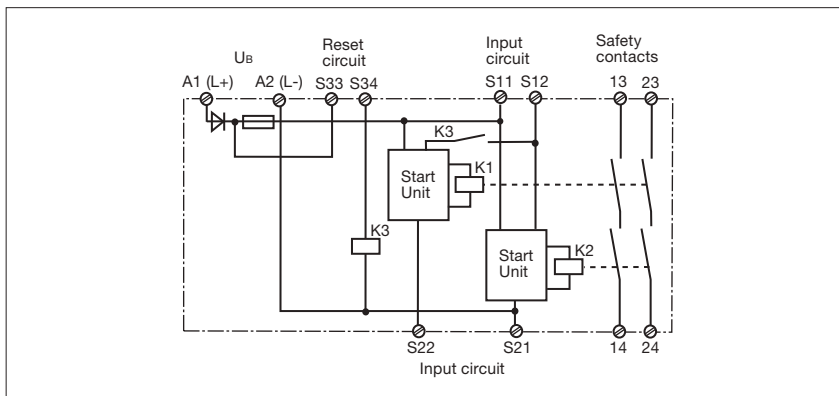

External Wiring

● Example 1

Single-channel E-STOP wiring with monitored manual reset, delay-on de-energisation: max. 100 ms

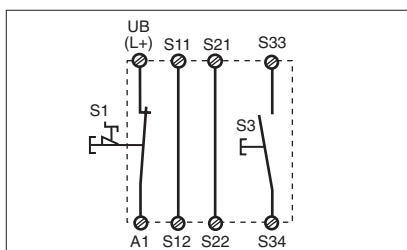

● Example 2

Dual-channel E-STOP wiring with monitored manual reset.

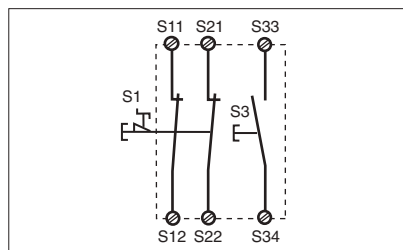

● Example 3

PNOZ X2.1 only: dual-channel E-STOP wiring with automatic reset.

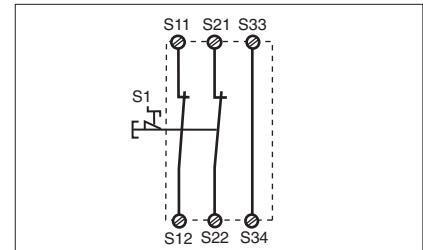

● Example 4

Dual-channel safety gate control through forced-contact limit switches with position monitoring.

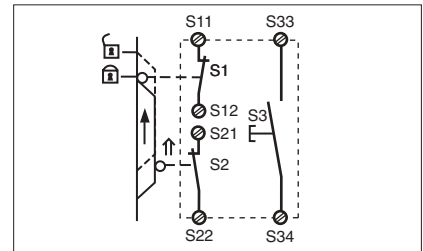

● Example 5

PNOZ X2.1 only: dual-channel safety gate control with automatic reset.

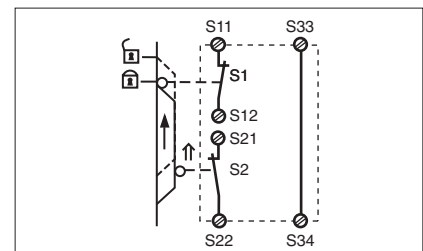

Category 4, EN 954-1

PNOZ X2, PNOZ X2.1, PNOZ X2.2

- Example 6

PNOZ X2.2 only: dual-channel

E-STOP wiring where units can be started in parallel using one reset button.

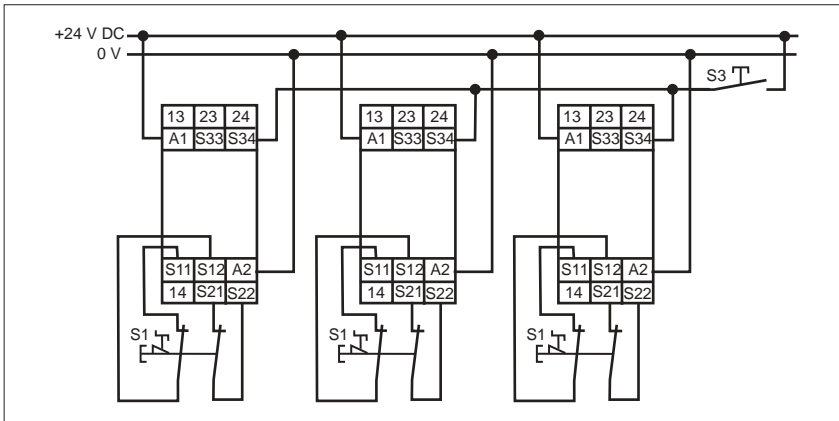

– Key

S1/2:	E-STOP or safety gate switch
S3:	Reset button
	Switch operated
	Gate open
	Gate closed

- Increase in safety contacts

The number of output contacts can be increased by using expander modules or relays/contactors with positive-guided contacts.

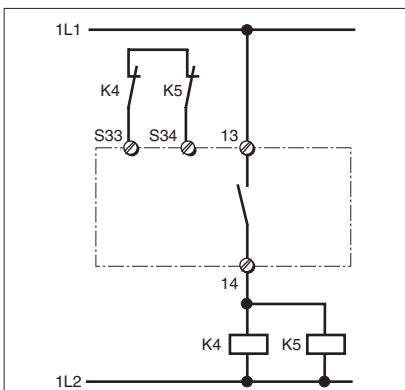

Category 4, EN 954-1

PNOZ X2, PNOZ X2.1, PNOZ X2.2

General Technical Data

Unless stated otherwise in the technical details for the specific unit

Electrical Data

Frequency Range AC	50 ... 60 Hz
Residual Ripple DC	160 %
Contact Material	AgSnO ₂
Continuous Duty	100 %

Environmental Data

EMC	EN 50081-1, 01/92, EN 50082-2, 03/95
Vibration in accordance with EN 60068-2-6, 04/95	Frequency: 10 ... 55 Hz, Amplitude: 0.35 mm
Climatic Suitability	DIN IEC 60068-2-3, 12/86
Airgap Creepage	DIN VDE 0110 part 1, 04/97
Ambient Temperature	-10 ... +55 °C
Storage Temperature	-40 ... +85 °C

Mechanical Data

Torque Setting on Connection Terminals	0.6 Nm (screws)
Mounting Position	Any
Housing Material	Thermoplast Noryl SE 100
Protection	Mounting: IP 54 Housing: IP 40 Terminal Range: IP 20

The units were tested in accordance with the relevant standards current at the time of development.

Order References

Type	U _B	Order No.
PNOZ X2	24 V AC/DC	774 303
PNOZ X2.1	24 V AC/DC	774 306
PNOZ X2.2	24 V AC/DC	774 607