



MASON INDUSTRIES, Inc.

Manufacturers of Vibration Control Products
 350 Rabro Drive 2101 W. Crescent Ave., Suite D
 Hauppauge, NY 11788 Anaheim, CA 92801
 631/348-0282 714/535-2727
 FAX 631/348-0279 FAX 714/535-5738
 Info@Mason-Ind.com Info@MasonAnaheim.com
 www.Mason-Ind.com

JOB NAME _____
 CUSTOMER _____
 CUSTOMER P.O. _____
 MASON M.I. _____
 DWG. NO. _____

ND
 Double
 Deflection
 Neoprene
 Mounts

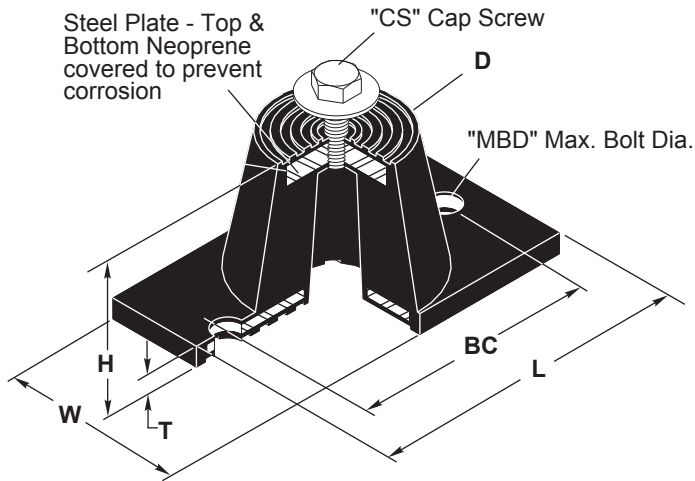

TYPE ND RATINGS

Size (Color Mark)	Duro- meter	Rated Capacity Range		Max. Rated Deflection	
		(lbs)	(kg)	(in)	(mm)
ND-A-Black	30	15-45	7-20	0.35	9
ND-A-Green	40	30-75	13-34		
ND-A-Red	50	60-125	27-57		
ND-B-Black	30	50-100	23-45	0.40	10
ND-B-Green	40	75-150	34-68		
ND-B-Red	50	110-235	50-107		
ND-B-White	60	180-380	82-172		
ND-B-Yellow	70	300-600	136-272		
ND-C-Green	40	140-260	64-118	0.50	13
ND-C-Red	50	200-400	91-181		
ND-C-White	60	310-600	141-272		
ND-C-Yellow	70	520-1000	236-454		
ND-D-Yellow	70	1060-2100	481-953	0.50	13
ND-DS-Yellow	70	2150-4300	998-1950	0.50	13

Mounts have straight line deflection curves.

TYPE ND DIMENSIONS

Size	D		H		L		T		W		BC		CS		MBD	
	(in)	(mm)	(in)	(mm)	(in)	(mm)	(in)	(mm)	(in)	(mm)	(in)	(mm)	(in)	(mm)	(in)	(mm)
ND-A	1 3/16	30	1 1/2	38	3 3/16	81	3/16	5	1 5/8	41	2 3/8	60	5/16-18 x 3/4" x 19		5/16	8
ND-B	1 3/4	44	1 7/8	48	3 7/8	98	1/4	6	2 5/16	59	3	76	3/8-16 x 1" x 25		5/16	8
ND-C	2 9/16	65	2 3/4	70	5 1/2	140	1/4	6	3 5/16	84	4 1/8	105	1/2-13 x 1" x 25		1/2	13
ND-D	3 3/8	86	2 3/4	70	6 1/4	159	5/16	8	4	102	5	127	1/2-13 x 1" x 25		1/2	13
ND-DS	3 3/8	86	2 3/4	70	6 3/4	171	5/16	8	4 3/8	111	5 1/2	140	1/2-13 x 1" x 25		1/2	13

PLAN VIEW OF MOUNT LOCATION

TAG : _____

UNIT : _____



SPECIFIED DEFLECTION

1 :	6 :
2 :	7 :
3 :	8 :
4 :	9 :
5 :	10 :
Sets Required:	