



High flow 3-stage pump unit

Choice of air or electric power options

Rigid, compact & lightweight

The Hi-Force TPA & TPE range of Premium line torque wrench pumps offers the following features :

F

- >> High speed 3-stage, 8 piston pump unit
- >> Multi outlet 4-way split block for simultaneous operation of up to 4 hydraulic wrenches
- >> Compact design, fitted within a rigid rollbar protection & carrying frame
- >> Automatically activated oil cooling heat exchanger fitted as standard on all electric driven models
- >> Exhaust air radiator cooling system on air driven models
- >> Adjustable torque setting pressure relief valve with locking nut
- >> Models with suffix 'A' fitted with analogue pressure gauge
- >> Models with suffix 'D' fitted with pressure transducer and digital pressure gauge
- >> Pendant controlled choice of manual with auto retract or full automatic cycle operation [automatic cycle functions only available on electric driven models]
- >> Solenoid valve with pendant control including motor on/off and 5 metre cable

Model number	Max. pressure Bar	Power supply	Pressure gauge	Gauge reading [*]	Displacements l / m		
					1 st stage 0-65 bar	2 nd stage 65-325 bar	3 rd stage 325-700 bar
Air driven pump units							
TPA07A	700	7.0 Bar air	analogue	Bar/PSI	7.0	1.6	0.80
TPA07D	700	7.0 Bar air	digital	Bar/PSI/Nm/Lbf.Ft	7.0	1.6	0.80
Electric driven pump units							
TPE15A	700	110V-1Ph-50Hz	analogue	Bar/PSI	6.5	1.5	0.75
TPE15D	700	110V-1Ph-50Hz	digital	Bar/PSI/Nm/Lbf.Ft	6.5	1.5	0.75
TPE16A	700	120V-1Ph-60Hz	analogue	Bar/PSI	7.8	1.8	0.90
TPE16D	700	120V-1Ph-60Hz	digital	Bar/PSI/Nm/Lbf.Ft	7.8	1.8	0.90
TPE25A	700	230V-1Ph-50Hz	analogue	Bar/PSI	6.5	1.5	0.75
TPE25D	700	230V-1Ph-50Hz	digital	Bar/PSI/Nm/Lbf.Ft	6.5	1.5	0.75
TPE26A	700	230V-1Ph-60Hz	analogue	Bar/PSI	7.8	1.8	0.90
TPE26D	700	230V-1Ph-60Hz	digital	Bar/PSI/Nm/Lbf.Ft	7.8	1.8	0.90
TPE45A	700	400V-3Ph-50Hz	analogue	Bar/PSI	6.5	1.5	0.75
TPE45D	700	400V-3Ph-50Hz	digital	Bar/PSI/Nm/Lbf.Ft	6.5	1.5	0.75
TPE46A	700	480V-3Ph-60Hz	analogue	Bar/PSI	7.8	1.8	0.90
TPE46D	700	480V-3Ph-60Hz	digital	Bar/PSI/Nm/Lbf.Ft	7.8	1.8	0.90

Note: [*] Torque value reading only available on software controlled, programmable pump unit



Maximum working pressure 700 Bar

Inbuilt oil cooling system

Multi-outlet block for operation of 4 wrenches

>> Optional extras include a full software controlled pump unit, enabling the user to select the hydraulic torque wrench in use via the digital display and have torque readings (in Nm or Lbf.ft) on the digital gauge. All Hi-Force TWS-N and TWH-N hydraulic torque wrenches are programmed and selectable as standard.

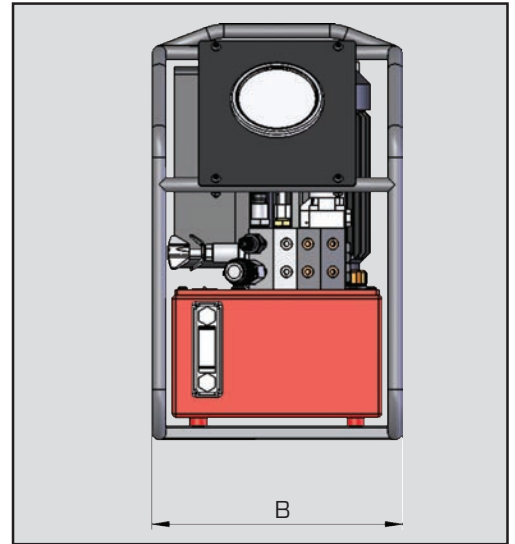
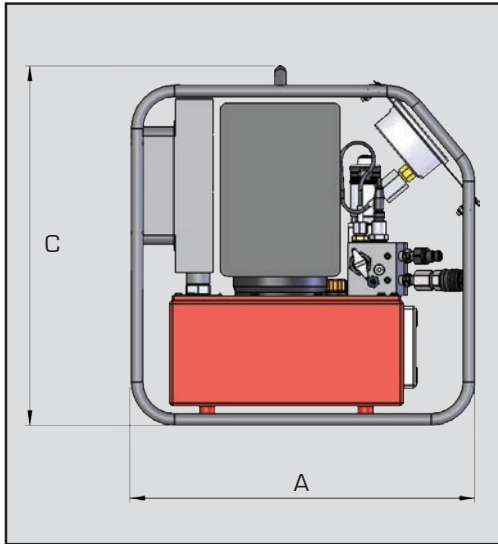

Pump Model	Oil capacity	Max. noise level	Max. oil temp	Weight incl. oil	Dimensions in mm		
					Length (A)	Width (B)	Height (C)
All TPA air driven models	7 litres	90 db (A)	80° C	30 kg	456	286	476
All TPE electric driven models	7 litres	88 db (A)	80° C	39 kg	456	286	476

Optional coupler sets for simultaneous operation of multiple torque wrenches (one set supplied fitted as standard):

Model number	Description
TP-CS1	Single set of male / female flat face couplers, for simultaneous operation of two hydraulic wrenches
TP-CS2	Double set of male / female flat face couplers, for simultaneous operation of three hydraulic wrenches
TP-CS3	Triple set of male / female flat face couplers, for simultaneous operation of four hydraulic wrenches