



aerospace
climate control
electromechanical
filtration
fluid & gas handling
hydraulics
pneumatics
process control
sealing & shielding



AC690+ Integrator Series Drives

Product Catalog



ENGINEERING YOUR SUCCESS.

 **WARNING - USER RESPONSIBILITY**

FAILURE OR IMPROPER SELECTION OR IMPROPER USE OF THE PRODUCTS DESCRIBED HEREIN OR RELATED ITEMS CAN CAUSE DEATH, PERSONAL INJURY AND PROPERTY DAMAGE.

This document and other information from Parker Hannifin Corporation, its subsidiaries and authorized distributors provide product or system options for further investigation by users having technical expertise.

The user, through its own analysis and testing, is solely responsible for making the final selection of the system and components and assuring that all performance, endurance, maintenance, safety and warning requirements of the application are met. The user must analyze all aspects of the application, follow applicable industry standards, and follow the information concerning the product in the current product catalog and in any other materials provided from Parker or its subsidiaries or authorized distributors.

To the extent that Parker or its subsidiaries or authorized distributors provide component or system options based upon data or specifications provided by the user, the user is responsible for determining that such data and specifications are suitable and sufficient for all applications and reasonably foreseeable uses of the components or systems.

OFFER OF SALE

The items described in this document are hereby offered for sale by Parker Hannifin Corporation, its subsidiaries or its authorized distributors. This offer and its acceptance by the provisions stated in the detailed 'Offer of Sale' which is available upon request.

Integrator Series AC Drive

AC690+ Integrator Series AC Drive

AC Drive 1 HP - 1500 HP

Table of Contents

		Page
General Information	Introduction to Parker Hannifin	4
	Service and support	8
	AC drives range overview	12
	DC drives range overview	14
AC690+	Description and Operating Modes	15
	Features	16
	Specifications	17
	AC690+ K Frame	18
	Electrical Characteristics	19
	Active Front End Regenerative Drives	21
	Dimensions	22
	Accessories and options AC690+	23
	Dynamic Braking	28
Packaged Drives	Pre-engineered configurable AC and DC drives	30
Software	Programming software tools for all drives	32
TS8000	TS8000 Human machine interface (HMI) touchscreens	33
	Communications options TS8000	37
Accessories	EMC filters	38
	Input and output reactors	39
Motors	Inverter and Vector Duty AC Motors	41

Parker Hannifin

The global leader in motion and control technologies and systems

Global Partnerships Global Support

Parker is committed to helping make our customers more productive and more profitable through our global offering of motion and control products and systems. In an increasingly competitive global economy, we seek to develop customer relationships as technology partnerships. Working closely with our customers, we can ensure the best selection of technologies to suit the needs of our customers' applications.



Electromechanical Technologies for High Dynamic Performance and Precision Motion

Parker electromechanical technologies form an important part of Parker's global motion and control offering. Electromechanical systems combine high performance speed and position control with the flexibility to adapt the systems to the rapidly changing needs of the industries we serve.



aerospace
climate control
electromechanical
filtration
fluid & gas handling
hydraulics
pneumatics
process control
sealing & shielding



About Parker Hannifin Corporation

With annual sales exceeding \$12 billion in fiscal year 2013, Parker Hannifin is the world's leading diversified manufacturer of motion and control technologies and systems, providing precision-engineered solutions for a wide variety of mobile, industrial and aerospace markets. The company employs approximately 58,000 people in 49 countries around

the world. Parker has increased its annual dividends paid to shareholders for 57 consecutive years, among the top five longest-running dividend-increase records in the S&P 500 index. For more information, visit the company's web site at <http://www.parker.com>, or its investor information site at <http://www.phstock.com>

Electromechanical Automation

Global products with local manufacturing and support

Global Product Design

Parker Hannifin has more than 40 years' experience in the design and manufacturing of drives, controls, motors and mechanical products. With dedicated global product development teams, Parker draws on industry-leading technological leadership and experience from engineering teams in Europe, North America and Asia.

Local Application Expertise

Parker has local engineering resources committed to adapting and applying our current products and technologies to best fit our customers' needs. Parker's engineering resources also extend to the development and manufacture of complete systems for continuous process and motion control applications.

Manufacturing to Meet Our Customers' Needs

Parker is committed to meeting the increasing service demands that our customers require to succeed in the global industrial market. Parker's manufacturing teams seek continuous improvement through the implementation of lean manufacturing methods throughout the process. We measure ourselves on meeting our customers' expectations of quality and delivery, not just our own. In order to meet these expectations, Parker operates and continues to invest in our manufacturing facilities in Europe, North America and Asia. This allows us to minimize transportation time and cost and to be able to respond more quickly to customer needs.

Worldwide Electromechanical Automation Locations

North America

Charlotte, North Carolina
Rohnert Park, California
Irwin, Pennsylvania
New Ulm, Minnesota

Europe

Littlehampton, UK
Dijon, France
Offenburg, Germany
Milan, Italy

Asia

Wuxi, China
Chennai, India

SSD Drives Division Manufacturing

Parker SSD drive products are manufactured globally to provide our customers with quality products at a competitive price point. In addition to factory-direct support, Parker provides sales assistance and local technical support through a group of dedicated sales teams and a network of authorized systems integrators, field service engineers, and technical distributors across the globe. For contact information, please refer to the Sales Offices listed on the back cover of this document or visit www.parker.com/ssdusa



Charlotte, NC



Littlehampton, UK



Wuxi, China



Chennai, India

Solutions to Improve Productivity, Increase Flexibility and Save Energy

Process Productivity and Reliability

Parker brings together the technology and experience required for continuous process applications across many industries. AC and DC variable speed drive products combined with application-specific function block-based configuration software ensure precise speed control and reliable performance. Parker combines more than 30 years of adjustable speed drive application experience with a global sales and support network to help you increase productivity and efficiency.

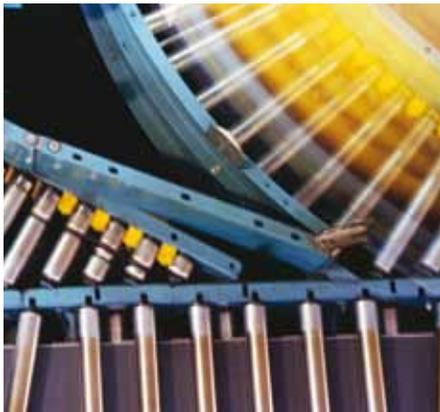

	AC Drives	DC Drives	Direct Drive Motors	Servo Drives and Motors
Converting machinery				
Folding, gluing, stitching and collating	√	√		√
Coating, laminating and foil stamping	√	√	√	√
Slitting, cutting and rewinding	√	√	√	√
Plastics processing machinery				
Plastic extrusion	√	√	√	
Injection moulding	√		√	√
Thermal forming	√		√	√
Wire and cable				
Wire and cable manufacturing	√	√		√
Winding/unwinding	√	√	√	
Extrusion for wire and cable	√	√	√	
Printing machinery				
Web/sheetfed offset	√		√	√
Flexographic printing	√		√	√
Gravure printing	√		√	√
Shaftless printing	√		√	√
Other industries				
Paper machinery	√		√	
Textiles	√	√	√	√
Steel production	√	√	√	
Hoists, cranes, and lifts	√	√		
Automotive test rigs	√	√	√	√

Energy Efficiency and Clean Power

Parker has developed the technology to maximize the efficient use of energy in industrial, mobile and commercial environments.

Hybrid Vehicle Technology

Parker has adapted its electric drive technologies for use in hybrid and electric vehicles, including mass transit, utility trucks, passenger vehicles, and watercraft. Examples include inverters and motor drives, charging systems, export power, and electric motors and generators. For more information, visit <http://hev.parker.com>

Energy Savings for Pumps, Fans, and Compressors

Parker has the drive technology to help you realize significant energy savings in the operation of pumps, fans and compressors in both industrial and commercial applications, including:

- Commercial refrigeration
- Water and wastewater treatment
- Building automation
- Industrial processes
- Hydraulic systems



Power Generation and Conversion

Using proven inverter technology, Parker has developed numerous solutions for the conversion of energy for commercial use from a variety of sources, including wind, wave and energy storage devices.

Motion Control Systems for Total Production Flexibility

Parker's electromechanical automation customers enjoy total production flexibility in their general and precision motion control applications. Complete packaged linear positioning systems, coupled to servo and stepper drives and control, enable our customers to develop a complete motion solution with one partner. Parker provides the products for a wide range of motion needs - power, speed, travel, force - with easy to use controls designed to work on multiple control and communication platforms. Additionally Parker's products can be easily customized to suit specific applications.



	Mechanical Actuators	Motors and Gearheads	Drives	Controls	HMI
Assembly machinery					
Pick and place	√	√	√	√	√
Lifting	√	√	√	√	
Transfer machinery	√	√	√	√	√
Automotive assembly					
Resistance welding	√	√	√	√	
Painting applications	√	√	√	√	√
Transfer machinery	√	√	√	√	√
Packaging machinery					
Primary, secondary, tertiary	√	√	√	√	√
Handling machinery	√	√	√	√	√
Food processing machinery					
Processing machinery	√	√	√	√	√
Packaging machinery	√	√	√	√	√
Handling machinery	√	√	√	√	√
Material handling systems					
Transfer systems	√	√	√	√	√
Pick and place systems	√	√	√	√	√
Metal forming machinery					
Presses	√	√	√	√	√
Tube bending	√	√	√	√	√
Handling machinery	√	√	√	√	√
Machine Tools					
Spindles		√	√		
Ancillary axes		√	√		
Semiconductor machinery					
Front end processes	√	√	√	√	√
Inspection machinery	√	√	√	√	√
Packaging machinery	√	√	√	√	√
Lithography	√	√	√	√	
Medical devices					
Device manufacture	√	√	√	√	√
Product packaging and dispensing	√	√	√	√	√
Scanning equipment	√	√	√		
Pumps and analyzers		√	√		
Entertainment					
Theatre and studio automation	√	√	√	√	
Simulation and amusement rides	√	√	√		
Ski Lifts and snow-making		√	√	√	√

Parker SSD Drives Service and Support

Preventative maintenance

Improve plant reliability and minimize production losses with Parker SSD.

With over 30 years experience of designing, manufacturing and supporting an extensive range of drives and motors, Parker SSD Drives ideally placed to offer the best possible levels of support to the customers.

With a variety of service and maintenance contracts available to choose from, it is possible to create a custom service package that meets your production needs and ensures that costly downtime is kept to a minimum and plant efficiency is kept at its optimum.



Training

Helping our customers become self-sufficient

Professional product training guarantees that your engineers and technicians are fully conversant and confident with the equipment that controls your process. With a number of different classroom and web-based courses running throughout the year covering all aspects of our drives range and meeting the specific needs of designers, programmers and maintenance staff, Parker SSD Drives provides its customers with the necessary skills to enable them to support their own equipment without the need of external assistance. If it is not convenient to travel to our training facility in Charlotte NC, we will come to you. Ask about our custom on-site training programs.

For a full list of currently available courses, please visit our website or ask your local territory manager.



Product Repairs

Any product returned to the dedicated repair facility at our Charlotte NC manufacturing facility undergoes a full visual inspection, professional repair and thorough test. In addition the equipment is updated to the latest relevant build standard and all parts replaced carry a warranty. For urgent situations, we offer an option for quick turnaround.

- **Repair using production parts**
- **Build standard update**
- **Standard or optional full diagnostic report**
- **Rapid turn around options**



Parker SSD Drives Service and Support

Field Service and Commissioning

A dedicated team of Parker SSD field service engineers strategically located across the country are available for on-site services.

- **System and drive commissioning and start-up**
- **Repair and replacement of components**
- **Preventative maintenance audits**
- **Software updates and upgrades**
- **Drive and PLC programming**

Call (704) 583-8134 to schedule Field Service



Technical Phone Support

You can count on excellent telephone support from our factory located team of product experts. We do not use an off-site call center, so you can be assured that any technical issues will be dealt with promptly and efficiently by experienced Parker SSD product support engineers.

- **Installation and set-up assistance**
- **Troubleshooting**
- **Spare and replacement part recommendations**
- **System optimization**
- **After-hours support**

Call (704) 602-6062 or email techsupport.us.ssd@parker.com for Technical Support

On-line Resources

Delivering information whenever you need it, our website is a valuable source of additional information and provides access to a wide range of documentation at anytime

- **Technical documentation, datasheets**
- **Product hardware and software manuals**
- **Legacy product manual archive**
- **Application notes and case studies**
- **Communication option files**
- **Software downloads and updates**
- **E-mail list for the latest news from SSD Drives**

For more information visit us on-line at:

www.parker.com/ssdusa



Parker SSD Drive Systems Capabilities

Engineered Solutions

Systems Build Capabilities

For customers preferring the convenience of more support in the design and implementation of their control systems, Parker SSD Drives and our network of integrators offer a complete in-house design and build service, enabling you to focus on your core competencies.

Based on the fundamental principles of application expertise, quality, reliability and safety, Parker's systems team are able to undertake all aspects of an electrical control system project, from pre-design specification to on-site installation and cabling services.

By allowing Parker or one of our qualified integrators to undertake the design, build, programming and commissioning of your motor control system, you can be

assured that every aspect of the design, from environmental considerations through component selection to mounting of products has been carefully considered and allowed for.

Fully documenting a complete control system can be a daunting task for many equipment manufacturers, again Parker are on hand to help by providing complete electrical schematic and single line drawings as well as installation, maintenance and operating instructions.

As an accredited systems builder, Parker SSD Drives are also able to undertake the certification process required to enable systems to be put into service in any number of industrial markets.



Total Project Support

From concept to installation and beyond, Parker SSD Drives and our integrator network have a full range of complimentary capabilities to provide as much or as little support to your own team's expertise as you need. With a team of highly qualified and experienced design, build and service engineers, we take the risk out of any capital project by ensuring that all stages of the project are managed and executed precisely to your requirements.

Holding certification to the latest quality standards (ISO 9001 - 2008) means that as a customer, you can be assured of reliable, repeatable quality of design, build and documentation.

Integrators

Parker SSD Drives is pleased to be backed by an extensive array of systems integrators with a plethora of controls experience. Each of our integrators has their own knowledge base in specific fields which allows us to provide support to a broad spectrum of markets. Our integrators offer a means for you to work with local engineering, service and support companies who pride themselves on catering to your facilities needs by improving system processes, eliminating downtime or simply helping you bring new products to market.





Together, we can take control of your applications. As well as your costs, design, quality, delivery, installation, after-sales support ...



Whether you're looking for a single drive in an enclosure for basic speed control, or a multi-bay automated drive system for complex control of a dockyard crane, high-speed printing machine or steel rolling mill, Parker Hannifin's SSD Drives Division has the expertise to deliver. Partnering with Parker SSD provides you with access to a host of additional services, all supplied to the same exacting standards as our AC,DC, systems and servo drive products. So relax and let Parker SSD take control of your panel-build, installation, commissioning and aftersales needs.

aerospace
climate control
electromechanical
filtration
fluid & gas handling
hydraulics
pneumatics
process control
sealing & shielding



ENGINEERING YOUR SUCCESS.

Variable Speed AC Drives

Range Overview Fractional to 2000 HP

Global AC Drive Solutions to Improve Productivity and Save Energy

Parker assists its customers in improving productivity and reducing energy consumption with a comprehensive, range of AC drives and drive systems. Parker AC drive products are sold, supported and serviced worldwide, with solutions from simple speed control to complex coordinated process control. Parker AC drive products are easy to configure and commission, with simple but flexible function block-based configuration tools and connectivity with all major industrial fieldbus networks.

Energy Savings Using Variable Speed Drive Technology

The application of variable speed drives to traditional fixed speed applications, such as in pumps, fans and compressors, can yield up to 30% energy savings. In fact, many power utilities and government agencies provide financial incentives to invest in VSD technology. Parker's AC650 and AC650V General Purpose AC drives make these savings possible.

Improving Process Productivity and Reliability

Parker AC drive products also have the functionality, designed and refined from decades of experience, to provide the precise, coordinated speed control, often among multiple motor axes, to ensure process line success.

AC Drives Product Range Overview

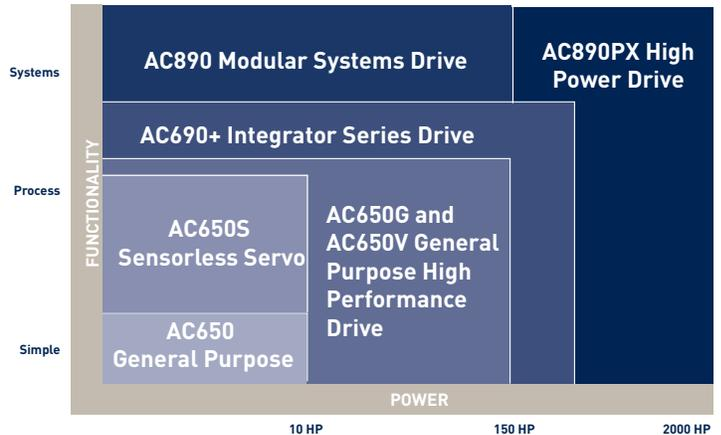

With high speed communication, easy to use configuration tools and HMI control solutions, Parker AC drives can handle the most complex process control applications.

Clean Power for Additional Energy Savings

Parker's AC drive products are frequently to be found at the heart of clean power solutions through Active Front End and line regeneration technology, producing additional energy savings through power factor control.

General Purpose AC Drives: AC650 Series

The AC650 is a simple, compact, cost effective solution to basic Volts/Hertz open-loop motor speed control applications to 10 HP, such as:

- Conveyors
- Pumps and fans
- Machine spindles

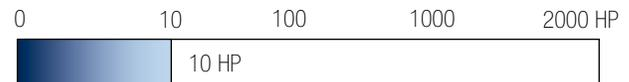

High Performance AC Drives: AC650G/V Series

The AC650G and AC650V expand upon the AC650 and benefits from the addition of sensorless flux vector control. This makes them ideally suited for applications up to 150 HP where improved speed regulation of variable loads and higher starting torques for high inertia systems is required.

- Centrifugal pumps
- Industrial blowers and fans
- Mixers

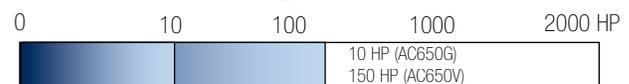

Variable Speed AC Drives

Range Overview Fractional to 2000 HP

Compact Drive for Sensorless Servo Control: AC650S Series

The AC650S series is designed to save energy in general purpose applications by replacing induction motors by more efficient permanent-magnet motors. Easy to commission and maintain, it controls the motor without a speed sensor. The AC650S is an effective solution where:

- Energy savings are required: pumps, fans, hydraulic systems, compressors
- Compactness is required: machine tools, packaging machinery, conveyors, winders/unwinders



High Performance Drives for Integrators: AC690+ Series

The AC690+ Integrator series provides high performance motor control for more complex or demanding applications up to 1500 HP. Available with multiple communications and control options for flexibility. Typical applications include:

- Multi-motor drive systems for process lines
- Distributed systems with communications
- High performance test equipment including 4-quadrant regenerative operation



Modular AC Systems Drives: AC890 Series

The AC890 Series is a range of modular AC drives, designed to minimize space and maximize performance in multiple axes applications. This AC890 Series can provide torque, speed and position control and can be configured to control permanent magnet servo motors in addition to induction motors. Available as stand-alone or common bus DC modules. Typical applications include:

- Printing machinery
- Converting machinery: coating, cutting, laminating
- High performance multi-axis machinery including 4-quadrant regenerative operation



High Power AC/Servo Drives: AC890PX

The AC890PX is a high power modular systems drive designed for industrial and power conversion applications. Available as a standalone drive or as part of a high power drive system, the AC890PX features removable phase and control modules, which allow for simple servicing and flexible system design. Power output to 1800 HP. Typical applications include:

- Extruders
- Pumps and Fans
- Mixers, centrifuges
- Engine dynamometers
- Power conversion inverters



Variable Speed DC Drives

Range Overview 1 HP - 2000 HP

Global DC Drive Solutions to Maximize Flexibility and Increase performance

With more than 30 years of worldwide application experience, Parker assists its customers in improving productivity and reducing energy consumption with a comprehensive, robust range of DC drives and drive systems. Parker DC drive products are sold, supported and serviced worldwide, with solutions from simple speed control to complex multi-motor coordinated process control. Parker DC drive products are easy to configure and commission, with simple but flexible function block-based configuration tools and connectivity with all major industrial fieldbus networks.

Digital DC Drives Maximize Flexibility and Functionality

Using the same 32-bit control architecture as our current range of AC drive products, Parker's range of digital DC drives provides the same high level of functionality - and with it flexibility and performance - as comparable AC drive systems, while simultaneously allowing the user to integrate both AC and DC drive systems in a single machine with the same interface and software.

Retrofit Existing Applications with the Latest Technology

By retrofitting existing DC motor applications with Parker digital DC drives, the user can avoid the cost of replacing an existing functioning, DC motor with a similar AC drive system, while still enjoying the benefits of a flexible control platform and high performance drive.

DC Drives Product Range Overview

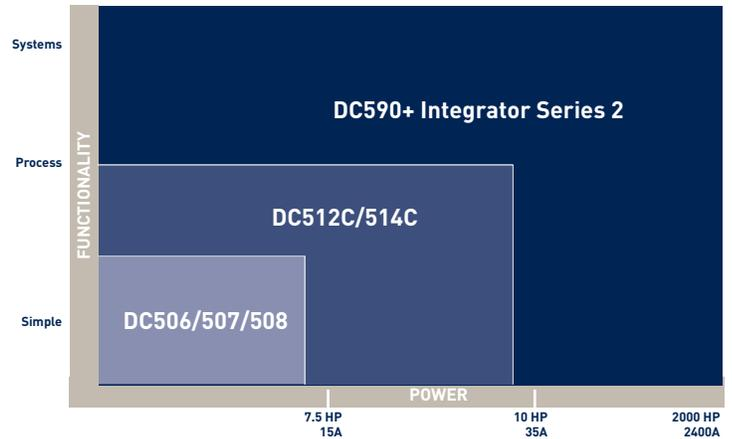

DRV Package - "Ready to Install" DC Drives

Save design time, panel space and the time and cost of component sourcing and installation with Parker's unique DRV drive format. DRV drives include all peripheral power components typically required in a DC drive system, integrated in a self-contained package. This package contains the additional components within the footprint of the standard drive module and saves significant panel space while reducing complexity and improving the appearance.

DC590+ Integrator Series 2 Digital DC Drive

The DC590+ uses an advanced control platform to provide high levels of flexibility and performance for a wide range of applications. Designed for machine integrators, the DC590+ features function block programming, multiple communications and feedback options and support worldwide. Available as non-regenerative or full four quadrant regenerative. Available from 1-2400A maximum. Fieldbus options include Profibus-DP, CANopen, Modbus RTU, Ethernet and DeviceNet.

Typical applications include

- Converting machinery
- Hoists and cranes
- Plastics processing machinery
- Wire and cable manufacturing
- Automotive test stands



Integrator Series AC Drives

AC690+ Series AC Drive

AC Drives 1 HP - 1500 HP

Description

The AC690+ Series is a single range of AC drives designed to meet the requirements of all variable speed applications from simple single motor speed control through to the most sophisticated integrated multi-drive systems.

The heart of the AC690+ is a highly advanced 32-bit microprocessor based motor control model. This provides an exceptional dynamic performance platform to which can be added a host of communications and control options, enabling you to tailor the drives to meet your exact requirements.

The AC690+ is available in 380-500V 3-phase 1 to 1500 HP and 220V-240V 1 to 60 HP, including single phase input for 1 to 3 HP.

Modes of Operation

The AC690+ can be user configured for different modes of operation:

Open-loop (volts/frequency) control

This mode is ideal for basic motor speed control, or multiple motors driven in parallel. The quick set-up menu and plain language display ensures the quickest and easiest, trouble free start up.

Sensorless vector control

High starting torque and tight speed regulation is provided by a sophisticated MRAS (Model Reference Adaptive System) motor control strategy. MRAS provides accurate speed simulation (without the need for any speed measuring transducer) by continually modelling the motor.

Closed-loop vector control

Full closed-loop flux vector performance can be achieved with the AC690+ by simply adding an encoder feedback 'technology box'. This provides 100% continuous full load standstill torque plus a highly dynamic speed loop (up to 45 Hz bandwidth); more than sufficient for the most demanding of applications.



Line Regenerative

Some applications require full four quadrant operation or extensive braking capabilities. The AC690+ series offers an energy efficient alternative to dynamic braking resistors in its Active Front End (AFE) unit. The AFE allows regenerative power to be returned to the grid safely and efficiently, and at unity power factor. The AC690+ AFE can also be used for situations that require ultra-low harmonics. An AFE package is offered, complete with LCL filter and other required components. See page 35 for details.

Integrator Series AC Drive

AC690+ Series AC Drive

AC Drives 1 HP - 1500 HP

Features

Encoder feedback option with encoder technology box

The AC 690+ is converted from open-loop control to high performance closed-loop control by simply adding the plug-in encoder feedback technology box.

High performance systems expansion module

The optional add-on “systems” expansion module is available for more advanced applications and includes phase locking between drives and register control. It fits behind the main control board and provides the following functionality:

- 5 configurable digital Inputs/ outputs
- Converts existing 4 analog inputs to high resolution (12 bit plus sign)
- 2 encoder inputs
- 2 high speed register mark inputs

Integrated function blocks

- Winder Control
- Process PID
- Raise/Lower
- Spinning Load Start

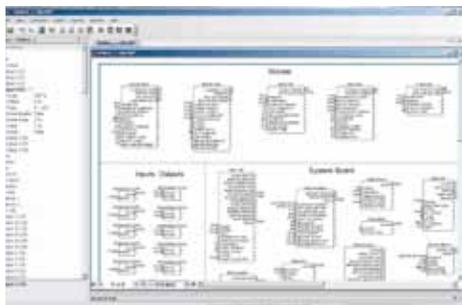

Mechanical protection options to suit all environments

A choice of mechanical protection options allows the drive to be mounted in a variety of different operating environments.

- **IP20** - for mounting inside an electrical enclosure.
- **IP40/NEMA 1** - The optional top cover, with cable gland plate enables the drive to be directly wall or machine mounted. (Frames B to E)
- **IP54** - Ideal for mounting in aggressive environments. Higher levels of protection are available as a special build option on request. A multitude of control options can be added to the drive using our Packaged Drive service.
- **Through-panel mounting** - This option allows the drive to be mounted with the major heat producing components and heatsink outside the enclosure, keeping the electronics clean and cool. (Frames C,D, and E)

Open standard fieldbus communications

The AC690+ has a host of communication technology box options allowing seamless multi-vendor integration into networked systems using the most common industrial fieldbus communications protocols :

- Profibus-DP
- Ethernet
- DeviceNet
- Modbus RTU
- CANbus
- ControlNet
- Modbus Plus
- SSD Link

Programming/Operator controls

The AC690+ HMI keypad comes standard with the drive, and provides access to all of the drive’s functions in a logical and intuitive manner. The readout is backlit and displays all functions in plain language and engineering units. The HMI can be mounted on the drive itself, or alternatively it can be supplied loose, with a mounting kit, for mounting remotely on a panel door, for example.

Integrator Series AC Drive

AC690+ Integrator Series AC Drive

AC Drive 1 HP - 1500 HP

Vector control with / without encoder feedback

Power ratings 1 HP - 1500 HP

Pre-programmed application Macros

Programmable over communications

Programming identical to DC590+ DC drive

Variable torque ratings

Class B EMC filters



Technical Specification

Power Supply	380-460V (±10%) 3-phase 1 to 1500 HP 380-500V (±10%) 3-phase 2.2 to 110kW 220-240V (±10%) 1-phase 1 to 3 HP 220-240V (±10%) 3-phase 1 to 60 HP
Operating Temperature	Constant torque - 0-45°C (40°C with IP40 cover) Derate 2% per degree C to 50°C max (Frame B-F) Derate 1% per degree C to 50°C max (Frame G-J) Derate 1.5% per degree C to 50°C max (Frame K)
Altitude	Maximum altitude: 1000m (Derate by 1% for every 100m above 1000m to 2000m maximum)
Overload	Constant torque: 150% for 60 seconds, 180% for 1 second Variable torque: 110% for 60 seconds
Output Frequency	Volts/Hertz mode: 0-1000 Hz Sensorless Vector mode: 0-120 Hz Closed Loop Vector mode: 0-300 Hz
Switching Frequency	Frame B: 3,6 or 9kHz Frame C, D, E and F: 3 or 6kHz All with audibly silent switching frequency
Dynamic Braking	Each drive can be fitted with an internal dynamic brake switch Frame B and C: standard Frame D,E and F: optional
Analog Inputs	4 Configurable, 10 bits (13 bits with optional system card). 0-10V, 0-±10V, 0-20mA, 4-20mA
Analog Outputs	3 Configurable, 10 bits. 0-10V, 0-±10V, 0-20mA, 4-20mA
Digital Inputs	7 Configurable, nominal 24VDC (30VDC max)
Digital Outputs	3 Configurable, relay contacts 3A/230 VAC
Reference Supplies	+10VDC, -10VDC, +24VDC
Motor Thermistor Input	Yes

Function Block Programming	Function block programming allows a tremendously flexible control structure to be created with ease. An almost infinite combination of user functions can be realized often alleviating the need for an external PLC. However, the drive is pre-configured so it can be used straight from the box as a standard AC drive without further adjustment.
Analog Functions	If So, summing, subtractor, multiplier, divider, if higher then lower then If, Counter, Timer
Boolean Functions	Not, And, Nand, Or, Nor, Xor, Trigger, Flip-Flop
Application Macros	Simple speed control, Forward/Reverse, Raise/Lower, Process PID, Preset speeds, Winder control.
6901 Operator Keypad	The 6901 keypad is designed for setting-up, configuring and operating the AC690+ drive. The intuitive menu navigation and parameter display is simple and easy to use. Main features: <ul style="list-style-type: none"> • Remote mounting capability on front of enclosure • Backlit display • Multilingual 2x16 alphanumeric display • Customizable display • Local Control: Speed setpoint, Start/Stop, Jog and Direction • Password protection • Quick set-up mode
Systems Expansion Module	The optional systems expansion module allows for advanced applications such as phase locking between drives and register control. Key features include: <ul style="list-style-type: none"> • 5 Additional user configurable Inputs / Outputs • 4 High resolution analog inputs (12 bits plus sign) • 2 Additional encoder inputs • 2 High speed register mark inputs • Encoder slave repeater

Integrator Series AC Drive

AC690+ Series AC Drive

K-Frame 600 HP - 1500 HP



Energy Savings

Fast return on investment in pump and fan applications

Improved power factor

Flux vector control with or without encoder and V/F control

Reduced harmonics through 12 or 18 pulse coupling

Improved HVAC control

Standards

Most standard products in the AC690+ series meet the following standards when installed in accordance with the relevant product manual. Consult factory for verification of standards for specific part numbers.

CE Marked to EN50178 (Safety, Low Voltage Directive)

CE Marked to EN61800-3 (EMC Directive)

UL Listed to US safety standard UL508C.

cUL Listed to Canadian standard C22.2 #14.



Specifications

6 pulse Model	Power Rating	Constant torque : 600 - 1500 HP Variable torque : 700 - 1600 HP
	Supply Voltage	380-460Vac (±10%) 3-phase
	Disconnect Switch	Standard
	Input inductance	Standard for limiting harmonic current
	Output Choke	Standard
	Operator Panel	6901 operator keypad mounted on enclosure door
12 pulse Model (option)	Harmonics	Reduced harmonic current
	Power Rating	Constant torque : 600 - 1000 HP Variable torque : 700 - 1500 HP
	Supply Voltage	380-460Vac (±10%) 3-phase
	Disconnect Switch	Standard
	Input Transformer	(not included in the enclosure) optional 2 secondaries U/D
	Operator Panel	6901 operator keypad mounted on enclosure door
18 pulse Model (option)	Harmonics	Total harmonic distortion (current) in accordance with limits of IEEE 519 (1992)
	Power Rating	Constant torque : 900 - 1500 HP Variable torque : 1000 - 1600 HP
	Supply Voltage	380-460Vac (±10%) 3-phase
	Disconnect Switch	Standard
	Input Transformer	(not included in the enclosure) optional 3 secondaries phase shifted by 20°
	Operator Panel	6901 operator keypad mounted on enclosure door



Electrical Characteristics

AC690+ Integrator Series AC Drive

Power Supply 220-240V (±10%) 50/60 Hz

Part Number	Phases	Frame	Constant Torque		Variable Torque		Inductance	Braking Module
			Power (HP/kW)	Output Current (A)	Power (HP/kW)	Output Current (A)		
690+0001/230/1BN1	1	B	1/1.75	4.0	-	-	No	Yes
690+0002/230/1BN1	1	B	2/1.5	7.0	-	-	No	
690+0003/230/1BN1	1	B	3/2.2	10.5	-	-	No	
690+0001/230/1BN	3	B	1/1.75	4.3	-	-	No	
690+0002/230/1BN	3	B	2/1.5	8	-	-	No	
690+0003/230/1BN	3	B	3/2.2	10.5	-	-	DC	
690+0005/230/1BN	3	B	5/4	16	-	-	DC	
690+0007/230/1BN	3	C	7.5/5.5	22	-	-	DC	
690+0010/230/1BN	3	C	10/7.5	28	-	-	DC	
690+0015/230/1NN	3	D	15/11	42	20/15	54	DC	
690+0015/230/1BN	3	D	15/11	42	20/15	54	DC	Yes
690+0020/230/1NN	3	D	20/15	54	25/18.5	68	DC	No
690+0020/230/1BN	3	D	20/15	54	25/18.5	68	DC	Yes
690+0025/230/1NN	3	D	25/18.5	68	25/18.5	68	DC	No
690+0025/230/1BN	3	D	25/18.5	68	25/18.5	68	DC	Yes
690+0030/230/1NN	3	E	30/22	80	40/30	104	DC	No
690+0030/230/1BN	3	E	30/22	80	40/30	104	DC	Yes
690+0040/230/CNN	3	F	40/30	104	50/37	130	AC	No
690+0040/230/CBN	3	F	40/30	104	50/37	130	AC	Yes
690+0050/230/CNN	3	F	50/37	130	60/45	154	AC	No
690+0050/230/CBN	3	F	50/37	130	60/45	154	AC	Yes
690+0060/230/CNN	3	F	60/45	154	75/55	192	AC	No
690+0060/230/CBN	3	F	60/45	154	75/55	192	AC	Yes

Power Supply 380-460V (±10%) 50/60 Hz 3-phase

Part Number	Phases	Frame	Constant Torque			Variable Torque			Inductance	Braking Module
			Power (HP/kW)	Output Current (A)		Power (HP/kW)	Output Current (A)			
				400V	460V		400V	460V		
690+0001/460/1BN	3	B	1/1.75	2.5	2.5	-	-	-	-	Yes
690+0002/460/1BN	3	B	2/1.5	4.5	4.5	-	-	-	-	Yes
690+0003/460/1BN	3	B	3/2.2	5.5	5.5	-	-	-	-	Yes
690+0005/460/1BN	3	B	5/4	9	9	-	-	-	-	Yes
690+0007B/460/1BN	3	B	7.5/5.5	12	11	-	-	-	-	Yes
690+0010B/460/1BN	3	B	10/6	14	14	-	-	-	-	Yes
690+0015/460/1BN	3	C	15/11	23	21	20/15	30	27	DC	Yes
690+0020C/460/1BN	3	C	20/15	30	27	25/18.5	37	34	DC	Yes
690+0025/460/1NN	3	D	25/18.5	38	38	30/22	45	45	DC	No
690+0025/460/1BN	3	D	25/18.5	38	38	30/22	45	45	DC	Yes
690+0030/460/1NN	3	D	30/22	45	45	40/30	59	52	DC	No
690+0030/460/1BN	3	D	30/22	45	45	40/30	59	52	DC	Yes
690+0040D/460/1NN	3	D	40/30	59	52	50/37.5	73	65	DC	No
690+0040D/460/1BN	3	D	40/30	59	52	50/37.5	73	65	DC	Yes

Constant Torque ratings provide 150% overload for 60 seconds. Variable Torque ratings provide 110% overload for 60 seconds
To add System Expansion Module (page 44) change last character in part number from "N" to "S"

Electrical Characteristics

Power Supply 380-460V (±10%) 50/60 Hz 3-phase

AC690+ Integrator Series AC Drive

Part Number	Phases	Frame	Constant Torque			Variable Torque			Inductance	Braking Module
			Power (HP/kW)	Output Current (A)		Power (HP/kW)	Output Current (A)			
				400V	460V		400V	460V		
690+0050/460/1NN	3	E	50/37	73	73	60/45	87	87	AC	No
690+0050/460/1BN	3	E	50/37	73	73	60/45	87	87	AC	Yes
690+0060/460/1NN	3	E	60/45	87	87	75/55	105	100	AC	No
690+0060/460/1BN	3	E	60/45	87	87	75/55	105	100	AC	Yes
690+0075/460/CNN	3	F	75/55	105	100	100/75	145	125	AC	No
690+0075/460/CBN	3	F	75/55	105	100	100/75	145	125	AC	Yes
690+0100/460/CNN	3	F	100/75	145	130	125/90	165	156	AC	No
690+0100/460/CBN	3	F	100/75	145	130	125/90	165	156	AC	Yes
690+0125/460/CNN	3	F	125/90	180	156	150/110	205	180	AC	No
690+0125/460/CBN	3	F	125/90	180	156	150/110	205	180	AC	Yes
690+0150/460/CNN	3	F	150/90	180	180	150/110	205	180	AC	No
690+0150/460/CBN	3	F	150/90	180	180	150/110	205	180	AC	Yes
690+0175/460/CNN	3	G	175/110	216	216	200/132	260	260	External	No
690+0175/460/CBN	3	G	175/110	216	216	200/132	260	260	External	Yes
690+0200/460/CNN	3	G	200/132	250	250	250/150	302	302	External	No
690+0200/460/CBN	3	G	200/132	250	250	250/150	302	302	External	Yes
690+0250/460/CNN	3	G	250/160	316	316	300/180	361	361	External	No
690+0250/460/CBN	3	G	250/160	316	316	300/180	361	361	External	Yes
690+0300/460/CNN	3	G	300/180	361	361	350/220	420	420	External	No
690+0300/460/CBN	3	G	300/180	361	361	350/220	420	420	External	Yes
690+0350/460/CNN	3	H	350/220	420	420	400/250	480	480	External	No
690+0350/460/CBN	3	H	350/220	420	420	400/250	480	480	External	Yes
690+0400/460/CNN	3	H	400/250	480	480	450/300	545	545	External	No
690+0400/460/CBN	3	H	400/250	480	480	450/300	545	545	External	Yes
690+0450/460/CNN	3	H	450/280	520	520	500/315	590	590	External	No
690+0450/460/CBN	3	H	450/280	520	520	500/315	590	590	External	Yes
690+0500/460/CNN	3	J	500/315	590	590	550/355	650	650	External	No
690+0500/460/CBN	3	J	500/315	590	590	550/355	650	650	External	Yes
690+K0600/460/2G/N	3*	K	600	-	685	700	-	798	AC	No
690+K0600/460/2G/B	3*	K	600	-	685	700	-	798	AC	Yes
690+K0700/460/2H/N	3*	K	700	-	798	800	-	912	AC	No
690+K0700/460/2H/B	3*	K	700	-	798	800	-	912	AC	Yes
690+K0800/460/2H/N	3*	K	800	-	988	900	-	1120	AC	No
690+K0800/460/2H/B	3*	K	800	-	988	900	-	1120	AC	Yes
690+K0900/460/3G/N	3**	K	900	-	1028	1000	-	1197	AC	No
690+K0900/460/3G/B	3**	K	900	-	1028	1000	-	1197	AC	Yes
690+K1000/460/2J/N	3*	K	1000	-	1120	1100	-	1235	AC	No
690+K1000/460/2J/B	3*	K	1000	-	1120	1100	-	1235	AC	Yes
690+K1000/460/3H/N	3**	K	1000	-	1197	1200	-	1368	AC	No
690+K1000/460/3H/B	3**	K	1000	-	1197	1200	-	1368	AC	Yes
690+K1300/460/3H/N	3**	K	1300	-	1482	1500	-	1681	AC	No
690+K1300/460/3H/B	3**	K	1300	-	1482	1500	-	1681	AC	Yes
690+K1500/460/3J/N	3**	K	1500	-	1681	1600	-	1852	AC	No
690+K1500/460/3J/B	3**	K	1500	-	1681	1600	-	1852	AC	Yes

Constant Torque ratings provide 150% overload for 60 seconds. Variable Torque ratings provide 110% overload for 60 seconds
To add System Expansion Module (page 44) change last character in part number from "N" to "S"

*12-Pulse Input Optional

**18-Pulse Input Optional



4 Quadrant Power Module

AC690+ Integrator Series AC Drive
Active Front End Units 10 HP - 500 HP



Illustration shows typical panel including AC690+ with AFE and additional system components.

Description

Many applications depend on the drive for braking torque as well as motoring torque. While dynamic braking with a resistor can be effective for lighter or lower duty cycle braking, some applications demand more braking performance than traditional D/B can provide. In addition, traditional dynamic braking using a resistor is wasteful of energy, as the potential energy in the load is dissipated as heat. By using an Active Front End (AFE) configuration, energy from the load is returned back to the power grid at unity power factor, providing extremely effective and controllable braking, as well as energy efficiency.

Applications that can benefit from line regeneration include hoists and lifts, centrifuges, continuous web processes, and dynamometer test stands. An AFE may also be used in applications that require ultra-low harmonics.

This cost effective AFE package includes pre-charge circuit and LCL filter.

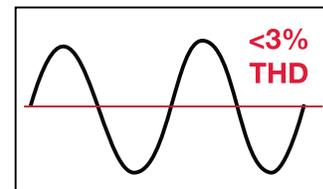
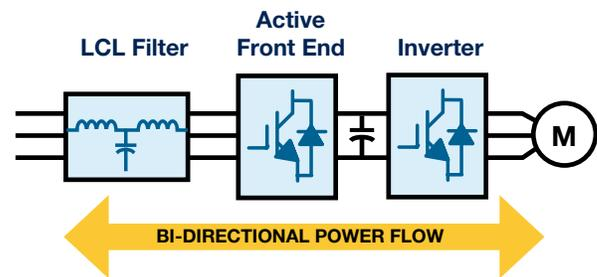

Part Number	Phases	Frame	Nominal Power (HP)	Dimensions (in)
AFE-13-LCL	3	B	13	22 x 18
AFE-26-LCL	3	C	26	28 x 22
AFE-45-LCL	3	D	45	33 x 27
AFE-85-LCL	3	E	85	46 x 34
AFE-125-LCL	3	F	125	46 x 34
AFE-167-LCL	3	F	167	46 x 34
AFE-200-LCL*	3	G	200	79 x 47 x 24
AFE-300-LCL*	3	G	300	79 x 47 x 24
AFE-350-LCL*	3	G	350	79 x 47 x 24
AFE-400-LCL*	3	H	400	79 x 47 x 24
AFE-500-LCL*	3	H	500	79 x 47 x 24

* Provided in NEMA 12 force ventilated cabinet with fans and filters

- Recovers wasted energy
- No braking resistor/No maintenance
- Ultra-low harmonics, meeting the requirements of IEEE 519
- High power factor ($\cos \phi \sim 1$)

Dimensions

AC690+ Integrator Series AC Drive

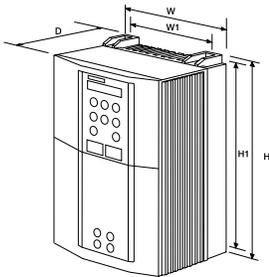

Frame B,C,D,E,F

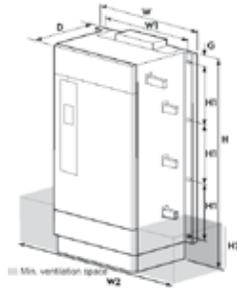

Frame G,H,J

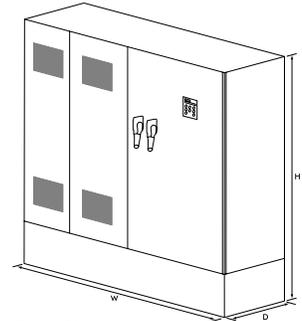

Frame K

Dimensions

Model	Dimensions (in/mm)			Mounting Centers (in/mm)					Weight (lb/kg)
	H	W	D	W2	H2	H1	W1	G	
Frame B	9.17/233	6.95/177	7.13/181	-	-	8.78/223	5.12/130	-	9.5/4.3
Frame C	13.7/348	7.91/201	8.19/208	-	-	13.19/335	5.91/150	-	20.5/9.3
Frame D	17.8/453	9.92/252	9.65/245	-	-	17.32/440	5.91/150	-	40.6/18.4
Frame E	26.3/669	10.1/257	12.28/312	-	-	24.80/630	5.91/150	-	72.0/32.5
Frame F	28.3/720	10.1/257	13.74/349	-	-	27.56/700	5.91/150	-	90.4/41.0
Frame G	41/1042	17.9/455	18.31/465	26.57/675	8.86/225	11.81/300	16.54/420	0.63/16	202/100
Frame H	46.3/1177	22.5/570	18.31/465	31.69/805	14.17/360	11.81/300	21.10/536	0.63/16	276/125
Frame J	50.7/1288	26.6/1177	18.31/465	32.48/825	13.11/333	11.81/300	25.24/641	0.63/16	388/176
Frame K - 685A, 798A, 988A, and 1120A ratings	79/2000	128/3251	24/610	-	-	-	-	-	-
Frame K - 1028A, 1197A, 1482A, and 1681A ratings	79/2000	176/4470	24/610	-	-	-	-	-	-



Accessories and Options

AC690+ Integrator Series AC Drive



Option Description	Frame	Part Number	Page
Operator Keypad			
AC690+ (removable)	B - K	6901/00/G	43
Advanced operator keypad (removable)	B - K	6911/01/00/G	
Remote mounting kit	B - K	6052/00	
Keypad Blanking Cover	B - K	LA500326U001	44
Communication Cards			
Ethernet Modbus/TCP and Ethernet IP	B	6053/ENET/00	40
	C - K	6055/ENET/00	
ControlNet	B	6053/CNET/00	
	C - K	6055/CNET/00	
Modbus Plus	B	6053/MBP/00	
	C - K	6055/MBP/00	
DeviceNet	B	6053/DNET/00	
	C - K	6055/DNET/00	
RS485 / Modbus	B	6053/EI00/00	
	C - K	6055/EI00/00	
Profibus-DP	B	6053/PROF/00	
	C - K	6055/PROF/00	
CANopen DS402	B	6053/CAN/00	
	C - K	6055/CAN/00	
LonWorks	B	6053/LON/00	
	C - K	6055/LON/00	
Link	B	6053/LINK/00	
	C - K	6055/LINK/00	
Apogee P1 (HVAC Series)	B	6053/APOG/00	
	C - K	6055/APOG/00	
Metasys N2 (HVAC Series)	B	6053/JMET/00	
	C - K	6055/JMET/00	
Speed Feedback / Systems Module			
HTTL Encoder Card	B	LA467461	41
	C - K	6054-00	
Systems Expansion Module	B - K	Specified in drive part number (S)	42
Other Options and Accessories			
Dynamic Braking Resistors	All	See table	44
Filters and Reactors	All	See table	112
IP40 Cover for Wall Mounting (Included standard with all part numbers ending in 1BN or 1NN)	B	LA467452	106
	C	LA465034U002	
	D	LA465048U002	
	E	LA465058U002	
DSE Lite Programming Software	All	DSE-Lite	106
Through-panel mount bracket assembly	C	LA465034U003	43
	D	LA465048U003	
	E	LA465058U003	
HMI Operator interface 3 to 15"	All	See TS8000 section	107
Conformal Coating	B - F	/083	43
Vent Kit	F	LA466717U003	44

Communication Cards

AC690+ Integrator Series AC Drive



Description

The selection of available AC690+ communication “technology boxes” allow the flexibility to be connected to the most common industry standard fieldbuses.

Features

- Communications cards can be factory installed into the drive, or purchased separately for installation on-site
- Dimensions H x W x D : 127mm x 76.2mm x 25.4mm
- LED indication of network and card status

Ethernet Communications Interface

*Part Number: 6053/ENET/00 and 6055/ENET/00	
Supported Protocols	Modbus/TCP and Ethernet IP
Communication Speed	10/100M bits/s
Station Address	Selectable via switch or Internet Explorer
Suitable for	AC690+ version 4.7+

ControlNet Communications Interface

*Part Number: 6053/CNET/00 and 6055/CNET/00	
Supported Messages	Polled I/O
Station Address	Selectable via Software
Suitable for	AC690+ version 4.7+

Modus Plus Communications Interface

*Part Number: 6053/MBP/00 and 6055/MBP/00	
Supported Protocols	Modbus Plus
Cabling	RS485 2 or 4 wire
Communication Speed	1 M bits/s
Station Address	Selectable via Software
Suitable for	AC690+ version 4.7+

Devicenet Communications Interface

*Part Number: 6053/DNET/00 and 6055/DNET/00	
Supported Protocols	DeviceNet Drive Profile Drive – Group 2 slave only
Station Address	DeviceNet Drive Profile Drive – Group 2 slave only
Suitable for Drives	AC690+

RS485/Modbus Communications Interface

*Part Number: 6053/EI00/00 and 6055/EI00/00	
Supported Protocols	Modbus RTU, EI Bisynch ASCII
Cabling	RS485 2 or 4 wire
Communication Speed	300 to 115200 bits/s
Station Address	Selectable via Software
Suitable for	AC690+ version 4.7+

Profibus-DP Communications Interface

*Part Number: 6053/PROF/00 and 6055/PROF/00	
Supported Protocols	Profibus-DP
Communication Speed	Automatically Detected
Station Address	Selectable via Software
Suitable for	AC690+ version 1.x+

CANopen Communications Interface

*Part Number: 6053/CAN/00 and 6055/CAN/00	
Profile	DS402
Supported Messages	SDO, PDO, NMT, SYNC
Communication Speed	20K, 50K, 125K, 250K, 500K, 1M bits/s selectable
Station Address	Selectable via Switch
Suitable for	AC690+

LonWorks

*Part Number: 6053/LON/00 and 6055/LON/00	
Supported Protocols	LonWorks
Delivered	with a resource file compatible with LonMaker software (or equivalent)
Suitable for	AC690+ HVAC Series version 5.1+

SSD Link

*Part Number: 6053/LINK/00 and 6055/LINK/00	
Supported Protocols	Parker SSD LINK
Cabling	Fiber Optic
Network speed	2.7 MBaud
Suitable for	AC690+

Apogee P1 (HVAC Series only)

*Part Number: 6053/APOG/00 and 6055/APOG/00	
Supported Protocols	Apogee P1
Suitable for	AC690+ HVAC Series

Metasys N2 (HVAC Series only)

*Part Number: 6053/JMET/00 and 6055/JMET/00	
Supported Protocols	Johnson Controls N2
Suitable for	AC690+ HVAC Series version 4.6+

* Refer to page 39 for details of drive frame compatibility



HTTL Encoder Feedback Card

AC690+ Integrator Series AC Drive



Description

The HTTL Encoder Feedback Card allows an incremental encoder to be connected to the AC690+ AC drive, allowing users to take full advantage of the integrated torque control and speed regulation functionality.

The HTTL Encoder Feedback card has the following features:

- 4 Optically isolated differential inputs A, B, M and H
- Adjustable isolated 10 - 20V encoder power output

Specifications

Maximum Input Frequency	250kHz
Receiver current consumption	≤10mA per channel
Input Format	2-channels in quadrature, clock / direction, or clock only
De-phasing	>1μs
Differential Input Voltage	10 - 30V Maximum
Encoder Power	Maximum Load: Card LA467461: 200mA or 2W Housing 6054-00: 250mA or 2.5W Voltage 10-20V software adjustable.

Installation and cabling

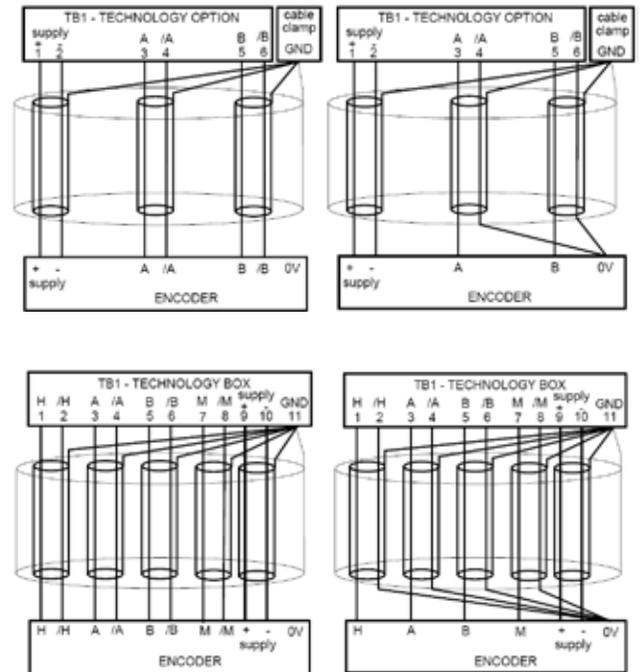

Part Numbers

Part Number	Compatible Drives
LA467461	AC690+ Frame B (690-xxxxxB...) drives
6054-00	AC690+ Frames C - K drives

AC690+ Frame B Drives

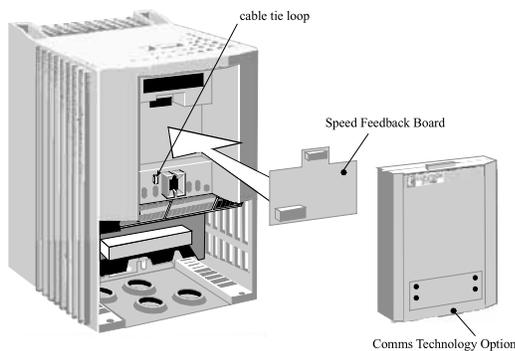

AC690+ Frames C-K Drives

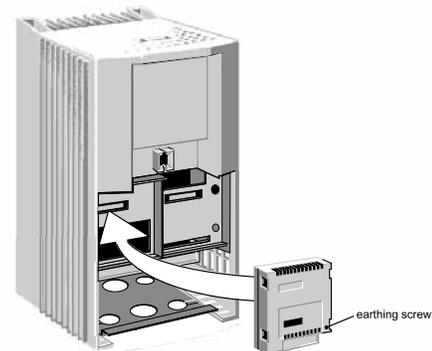

System Expansion Module

AC690+ Integrator Series AC Drive

Description

With the System Expansion Module, the AC690+ can be used in more sophisticated applications, or where a small amount of automation is required to be used in conjunction with the drive.

The following features are available:

Analog Inputs AIN1-4 are become high resolution (12 bit plus sign)

5 isolated I/O points, configurable as either inputs or outputs

Variable isolated output power for encoders

Master encoder inputs (Isolated HTTL): A, A/, B, B/, Z and Z/

Slave encoder inputs (Isolated HTTL): A, A/, B, B/, Z and Z/

Slave encoder output retransmission (Isolated HTTL): A, A/, B, B/, Z and Z/.



External Power Supply

An external 1 Amp 24VDC ($\pm 10\%$) supply must be connected to the card.

How to Order

Change last character of drive part number from "N" to "S".

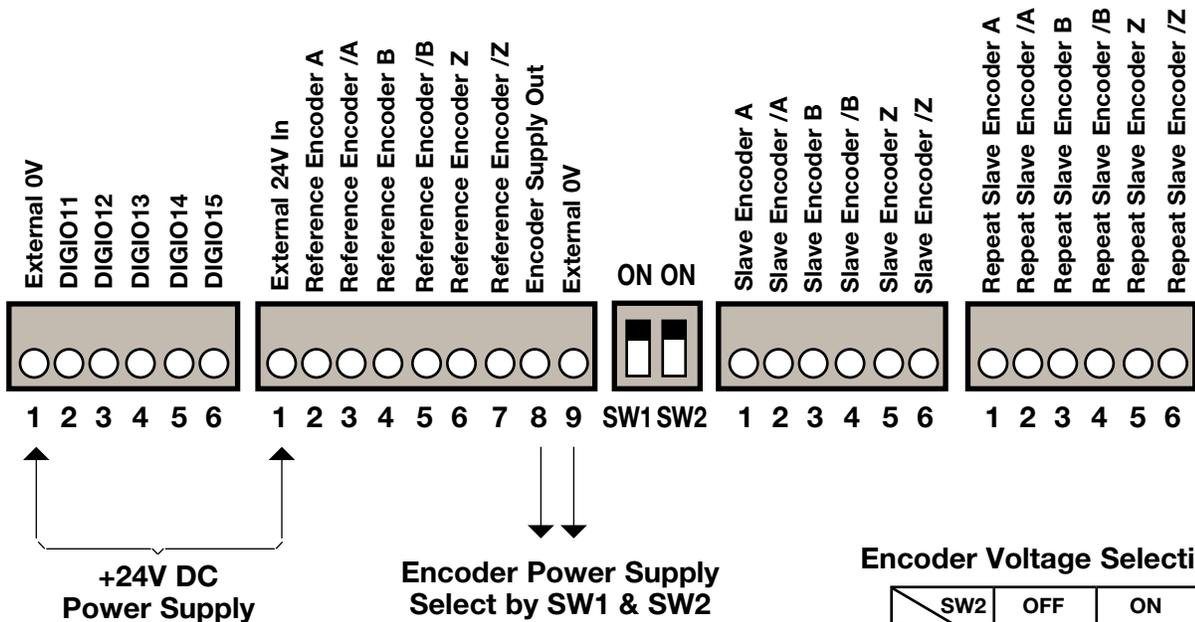

Operator Keypads

AC690+ Integrator Series AC Drive



Standard operator keypad 6901/00/G

Features

- Local motor control : start, speed, direction, diagnostics
- Operator menus and parameter configuration
- Quick setup menu
- Password protection for parameter configuration

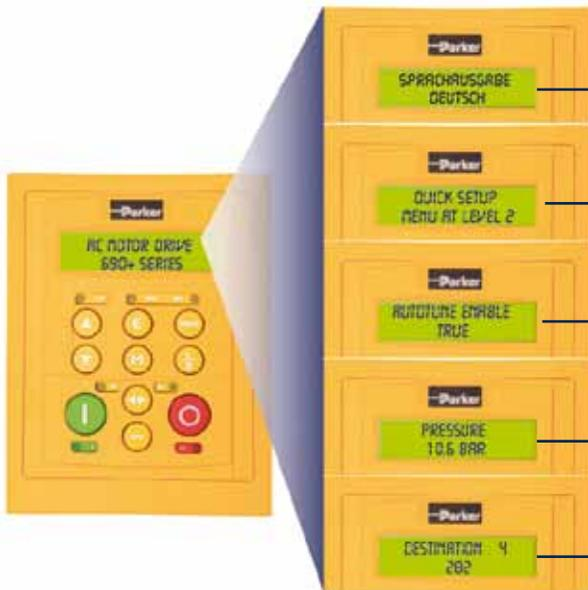

Multilingual

English · Spanish · French · German · Italian · Portuguese · Swedish · Polish

Quick setup menu

Intuitive menus allowing easy and quick setup of the drive

Auto-tuning

Automatic tuning of motor parameters ensures maximum dynamic motor performance

Diagnostics messages

Display input and output parameters as well as drive operating units

Drive configuration

Advanced operator keypad 6911/01/00/G

Features

- 128 x 64 pixels semi-graphical resolution
- RS232 and RS485 ports
- Recording of parameters to keypad and restore to drive (Memory card 256Mb to 2Gb)



Conformal Coating

For environments that have dusty, humid or corrosive atmospheres, the AC690+ family can optionally be supplied with conformally coated circuit boards that improve the drive's resistance to corrosion, thereby increasing reliability and service life. Environments that typically benefit from conformal coating include:

- Water and wastewater treatment plants
- Paper and pulp processing mills
- Steel mills
- Marine and offshore
- Outdoor cranes
- Wind & wave power generation
- Food and chemical processing plants

Through-panel Mounting Kit

Description

This option allows the heat sink of the drive to protrude through the back panel of an enclosure or cabinet, allowing the heat to be dissipated outside of the enclosure. This mounting configuration can generally permit the use of a smaller enclosure, or elimination of the need for air conditioning inside the enclosure. Please consult the installation manual for complete information regarding thermal management requirements for the drive or drives to be used.

Dynamic Braking Kit/Vent Kit

AC690+ Integrator Series AC Drive

D/B Kit includes resistor, overload, protective cage, and enclosure top or panel mounting							
Part Number	Voltage	Nominal Power - CT (HP)	Nominal Power - VT (HP)	Ohms	Amps	Watts	Dimensions (in) LxWxH
LA471358	208/230	1, 2, 3, 5	-	56	1.9	202	6.5 x 1.2 x 2.4
LA471406	208/230	7.5, 10	10, 15	30	3.5	368	13.5x4x5
LA471386	208/230	15	20	15	5	375	13.5x4x5
LA471378	208/230	20, 25	25	10	8.7	757	13.5x7x5
LA471407	208/230	30	40	7	10.4	757	13.5x7x5
LA471379	208/230	40	50	6	13.7	1126	13.5x10x5
LA471380	208/230	50, 60	60, 75	4	19.4	1505	13.5x13x5
LA471356	460	1, 2, 3	1, 2, 3	100	1	100	6.5 x 1 x 1.6
LA471404	460	5, 7.5, 10	5, 7.5, 10	100	1.9	361	13.5x4x5
LA471359	460	15	20	56	3	500	13.2x1.2x2.4
LA471405	460	20	25	60	3.5	735	13.5x7x5
LA471361	460	25, 30	30, 40	30	5	750	13.5x7x5
LA471350	460	40	50	22.5	7.1	1134	13.5x10x5
LA471364	460	50	60	18	7.9	1123	13.5x10x5
LA471365	460	60	75	15	8.7	1135	13.5x10x5
LA471367	460	75, 100	100, 125	8	13.7	1502	13.5x13x5
LA471369	460	125, 150	150	6	19.4	2258	13.5x10x5
LA471370	460	200	250	3	39	4563	20x18x10
LA471372	460	250, 300	300, 350	2.25	45	4556	20x18x10
LA471375	460	350, 400, 450	400, 450, 500	1.5	55	4538	20x18x10
LA471376	460	500	550	1.2	61	4465	20x18x10

*NEMA ICS 3-301.62 Dynamic braking stop option. Minimum 100% full load torque from base speed with 6x motor inertia, and 4 stops per hour.

Keypad Blanking Cover

Description

The keypad blanking cover kit may be used when local keypad is not installed. Kit includes light pipes for LED's.

Part Number	Description	Suitable for
LA500326U001	Blank Cover	AC690+ Frame B-J

Vent Kit

Description

For the two largest frame sizes, optional vent ducting kits is available. These kits provide a convenient means of venting hot exhaust air from the panel-mounted AC690+ drive. The kit includes a duct, attached to the top of the drive and the roof of your enclosure, and an air exhaust hood for mounting on the top of the enclosure. Mounting hardware and gasket are provided in the kit. Installation will require a rectangular hole and six mounting bolt holes to be cut through the top of your enclosure.

Part Number	Description	Suitable for
LA466717U004	Vent Kit	AC690+ Frame E
LA466717U003	Vent Kit	AC690+ Frame F



Packaged Drives

AC and DC Series

0.5 HP - 500 HP

Overview

For those applications that require more than a standard drive, Parker SSD offers a unique line of configurable packaged drives designed for maximum flexibility and minimum lead time.

By choosing from a list of standard drives, pre-engineered options, and a selected group of enclosures, you can configure a packaged drive with the features you need, then receive a quick quote and part number to order. Most

packages ship in two weeks or less, built to your specifications!

Packaged drives can include any Parker SSD drive, from the economical AC650/AC650V, to the AC690+ or DC590+ Integrator Series, to the AC890/AC890PX.

Any one of a wide variety of communications cards may be chosen to match your current network. Operator devices like basic pushbuttons, selector

switches, or indicator lights are available, as are power-handling components, including circuit breakers, line contactor, output reactor, or bypass arrangements.

To get started, visit our website, www.ssddrives.com/usa and click "Packaged Drives" on the menu to the left. Download the quote request form or complete the form on page 81 of this catalog and follow the directions to receive a fast custom quote.



Packaged Drive Benefits

- **Fast Delivery**
- **Ready-to-install standalone drive**
- **I/O interface compatible with most existing building management systems**
- **Wide range of ratings available up to 500 HP**
- **Extensive range of control options pre-engineered for fast delivery**
- **Easy commissioning**
- **Meets all relevant UL and EMC standards**
- **Economical...specify only the features you want**
- **Rugged industrial enclosures offer superior protection**

Packaged Drives

AC and DC Series

0.5 HP - 500 HP

3 Simple Steps to a Packaged Drive

1. Select the base drive model and HP rating from the Packaged Drive Quote Request Form (See page 103)



2. Select the control options and operator devices from the list of available items to suit your application

3. Submit the completed form to your local sales office or distributor for price and availability



Packaged Drives **Express** Quote Request Form

Company Info:

Company Name: _____ Contact: _____

Address: _____

City: _____ Zip/Postal Code: _____ Country: _____

Phone: _____ Fax: _____ E-mail: _____

Plant Power: 230VAC 460VAC 575VAC (AC890PX only) 690VAC (AC890PX only)**Drive Series:** AC650 AC650V AC690+ AC890 AC890PX DC590+ Regenerative
 Non-regenerative**Duty (AC drives only):** Constant Torque/Heavy Duty Variable Torque/Standard Duty**Rating:**

_____ HP _____ Full Load Amps (if known) For DC Drive: Field Volts _____ Amps _____

Feedback capability: Encoder _____ PPR Resolver (AC890 only) Endat (AC890 only)
 Tachometer (DC Drives only) _____ V/1000 RPM**Communications (subject to availability):** RS232/RS485/Modbus RTU EtherNet/IP Modbus/TCP
 Profibus – DP ControlNet Modbus Plus
 Lonworks CanOpen DeviceNet
 FireWire IEEE1394A FireWire IEEE1394B Link**Options:** Circuit breaker Input contactor Output contactor
 Output reactor (for motor leads >50m) Dynamic braking resistor HVAC Package (HVAC10)
 AC line reactor (Includes 3-contactor bypass, disconnect, overload, 115V transformer)**Operator devices:** 6901 keypad, door mounted E-Stop pushbutton Start p/b (illuminated)
 Stop pushbutton Reset p/b (illuminated) Jog Fwd pushbutton
 Jog Rev pushbutton Auto/Man selector switch Fwd/Rev selector switch
 Indicator light, Power On Indicator light, Healthy Indicator light, Run
 Speed pot, 10-turn Speed pot, 1-turn(Maximum of 6 operator devices OR keypad may be chosen)**Requested Lead Time: _____ Days****Additional Comments:**

Return this form to your Parker SSD territory manager by fax or e-mail. You will receive verification that your configuration is valid, and a price and confirmation of lead time within 48 hours. OR, send to info.us.ssd@parker.com or fax (704) 588-4806

Software Tools

For All Drives with communications

Drive System Explorer Software

DSE is the programming, monitoring and diagnostic software platform for SSD drives. Thanks to the on-line help, users can achieve the optimum drive configuration without the need to navigate through complicated parameter menus. Advanced programming is carried out through a set of pre-engineered templates in order to create the required configuration. It is possible to monitor every parameter of the drive either as a digital value or as a function in the “chart recorder” during normal operation.

While the drive is in running mode the oscilloscope function allows “on-line” monitoring of selected parameters and the recording of trends. Using straightforward block programming, DSE allows the user to create, parameterize and configure user defined applications thanks to function blocks dedicated to speed control, inputs, outputs, ramps, winder functions, PID, diameter calculator, and more. Groups of function blocks can be combined into macros for more complex programs.

There are three levels of DSE software available.

- DSE Lite is provided as a free download, and is a fully functional package for drive programming, configuration, status monitoring, and diagnosis.
- DSE Development software adds the capability to create and edit projects using AC890 with Firewire communications.
- DSE Runtime allows the user to edit projects using AC890 with Firewire communications, but not create new ones.

For users of DSD software who wish to migrate to the DSE platform, we offer upgrade packages for both development and runtime versions of that product.

System Requirements

- Windows Vista® or Windows® XP, Home or Professional Edition operating system
- 100Mb of free hard disk space
- USB port for connecting to an AC890 or AC890PX drive
- Serial port for connecting to AC650V, AC690+, DC590+, or legacy drives.

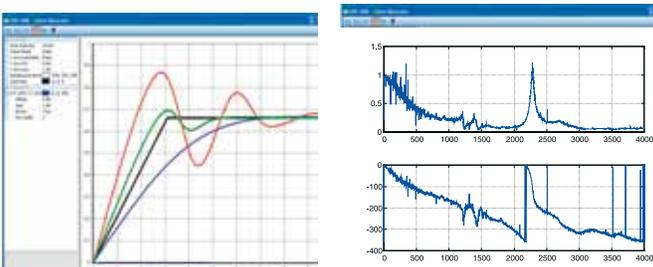

Real-time data acquisition and oscilloscope functions

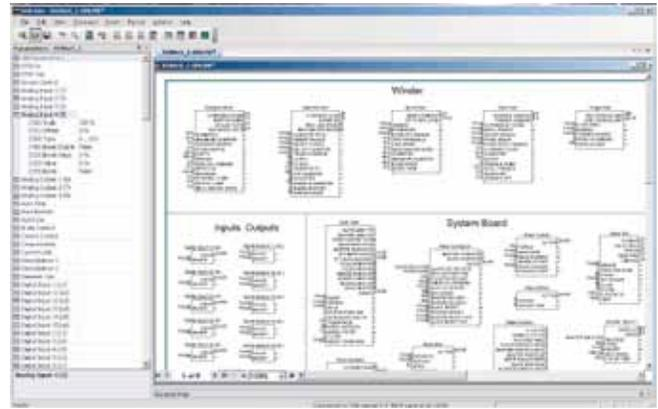

Function block configuration

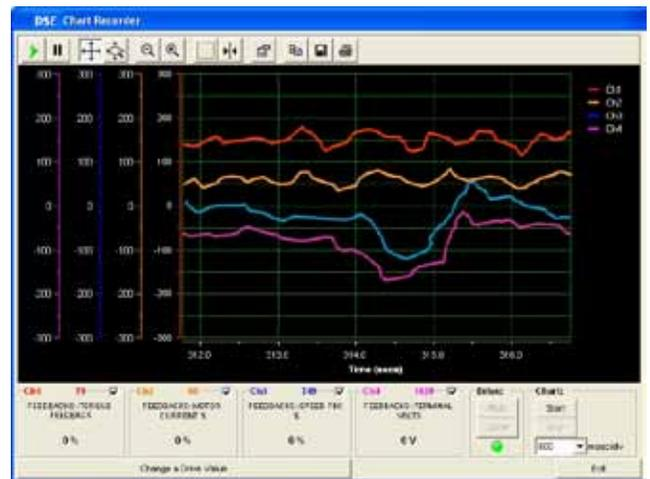

Chart recorder function

Drive System Designer (DSD)

DSD software is a package used to configure LINK systems. It employs a graphical interface and configurable function blocks that offer unlimited, interconnectable control schemes to create the desired configuration. Starting from a simple diagram of the line, machine, or process, the user can set the various parameters (line speed, tension, etc.) and functions (winder, taper, dancer, etc.) for each motor.

Part Number	Description
DSE-Lite	DSE Lite software (single axis) + USB cable*
8906-DSEDEV-00	DSE Development software + USB cable
8906-DSEDEV-00	DSE Runtime/Maintenance + USB cable
8906-DSEDEVUPG-00	DSD Development to DSE Development Upgrade + USB cable
8906-DSEDEVUPG-00	DSD Runtime to DSE Runtime Upgrade + USB cable
DSD-DEV	LINK Development
DSD-RUN	LINK DSD Runtime

* DSE Lite may also be downloaded free of charge



HMI Touchscreen

TS8000 Series



Description

TS8000 is a high performance web-enabled HMI touchscreen range with powerful features that would normally only be found in PC-based displays.

The TS8000 is able to communicate with many different pieces of hardware through its 10/100Base-T Ethernet port.

Furthermore a USB programming port allows programs to be downloaded, or access to trending and data logging, while data can be collected and stored on a standard CompactFlash card, freeing up internal memory.

Unlike similar competitive units, programming software for the TS8000 is a free download!

Multi-lingual graphical interface

Built-in symbol library of common objects

Built-in web server/Virtual Panel

CompactFlash support

Integrated automatic multiple protocol conversion

Free DSI8000 programming software

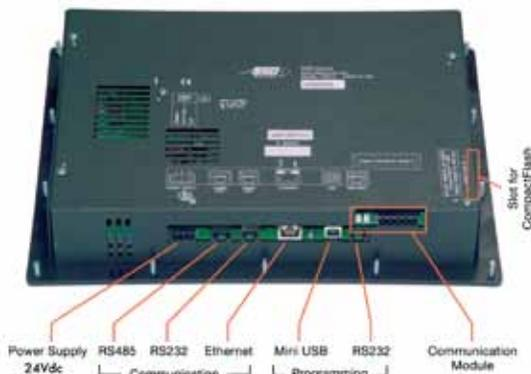

Technical specifications

Power Supply	24Vdc ±20%
Operating Temperature	0-50°C
Relative Humidity	80% non-condensing
Altitude	2000 m
Enclosure	IP66/Nema 4X
Keypads	<p>TS8003 :</p> <ul style="list-style-type: none"> . 8 user assignable keys . 5 navigation keys . 12 numeric keys . 7 dedicated keys <p>TS8006 : 5 programmable keys for on screen menus</p> <p>TS8008 : 7 programmable keys for on screen menus</p> <p>TS8010 : 8 programmable keys for on screen menus</p> <p>TS8015 : 10 programmable keys for on screen menus</p>
Memory	CompactFlash slot
Communication Ports	<p>Programming :</p> <ul style="list-style-type: none"> USB 1.1 - connector type B RS232 - via RJ12 <p>Communication :</p> <ul style="list-style-type: none"> . RS232 - via RJ12 . RS485 - via RJ45 . Ethernet 10/100 Base T - connector RJ45

HMI Specifications

Part Number	Screen	Colors	Pixels
TS8003/00/00	3.2"/FSTN	2	128 x 64
TS8006/00/00	5.7"/TFT	256 QVGA	320 x 240
TS8008/00/02	7.7"/TFT	256 VGA	640 x 480
TS8010/00/02	10.4"/TFT		
TS8015/00/00	15"/TFT	32,000 XGA	1024 x 768

HMI Touchscreen

TS8000 Series



Application Example



HMI Touchscreen

TS8000 Series



HMI Features

Pre-Engineered Projects

- Library with over 4000 symbols
- Support for BMP, JPG, WMF graphic files
- Database functionality
- Graphical Trending
- Alarm Logs
- Machine Drawings

Multilingual Interface

Programming and Display in:

Italian	German
English	Spanish
French	Dutch
Thai	

Unicode* Support for:

Japanese	Chinese (traditional)
Korean	Chinese (simplified)
Other languages available	

*Unicode support requires MS Windows language packs to be installed

Dimensions (in/mm) and Weights

Part Number	a	b	c	d	e	Weight (lb/kg)
TS8003/00/00	7.45/189.2	5.85/148.6	2.1/52	6.04/153.4	4.44/112.8	1.96/0.89
TS8006/00/00	8.83/224.3	7.08/179.8	2.3/58.4	7.42/188.5	5.67/144	3.0/1.36
TS8008/00/02	10.32/262	8.18/207.8	2.2/56	8.91/226.3	6.77/172	3.84/1.74
TS8010/00/02	12.83/325.8	9.5/241.3	2.2/56	11.55/293.3	8.27/210.1	5.53/2.51
TS8015/00/00	16.0/406.4	13.0/330.2	2.8/71.5	14.59/370.6	11.59/294.4	11.41/5.17

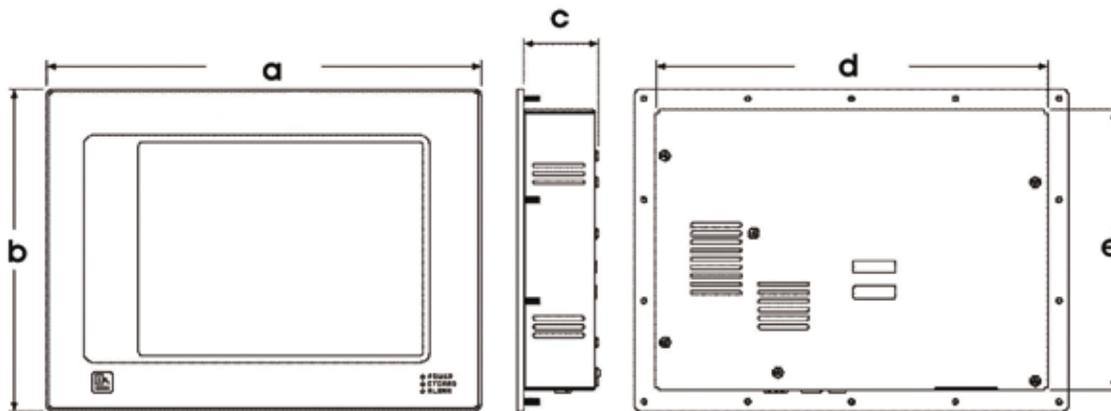

Options

Part Number	Description
8000/CB/00/00	CanOpen fieldbus option card (master)
8000/DN/00/00	DeviceNet option card
8000/PB/00/00	Profibus option card
8000/LK/00/00	LINK fieldbus option card
8000/FA/00/00	FireWire fieldbus option card

International Standards

Complies with standards:

- EN61010-1
- EN61326
- EN55011 Class A

CE Marked

HMI Touchscreen

TS8000 Series



HMI Applications

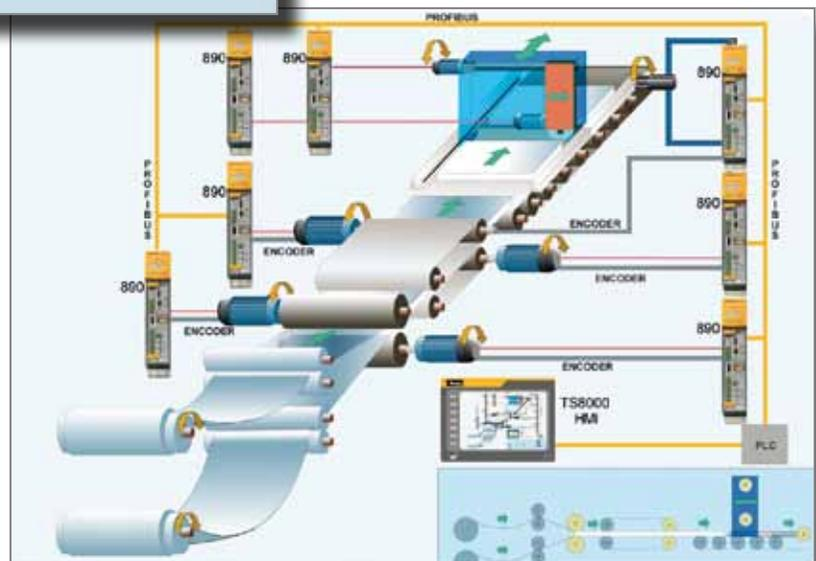
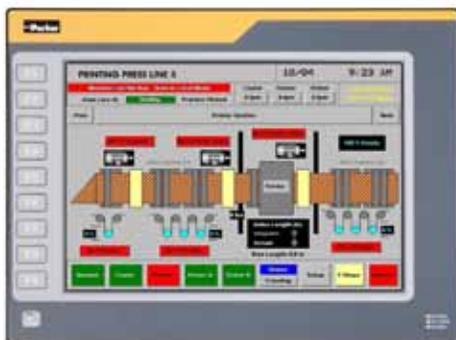
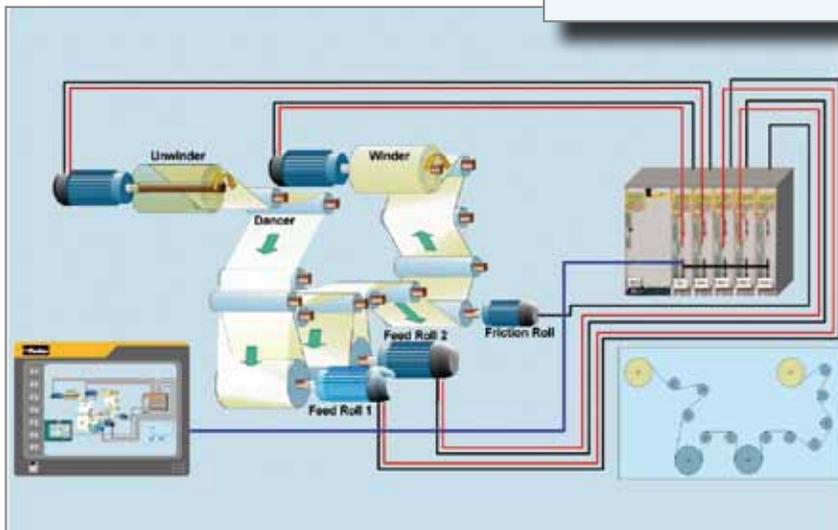
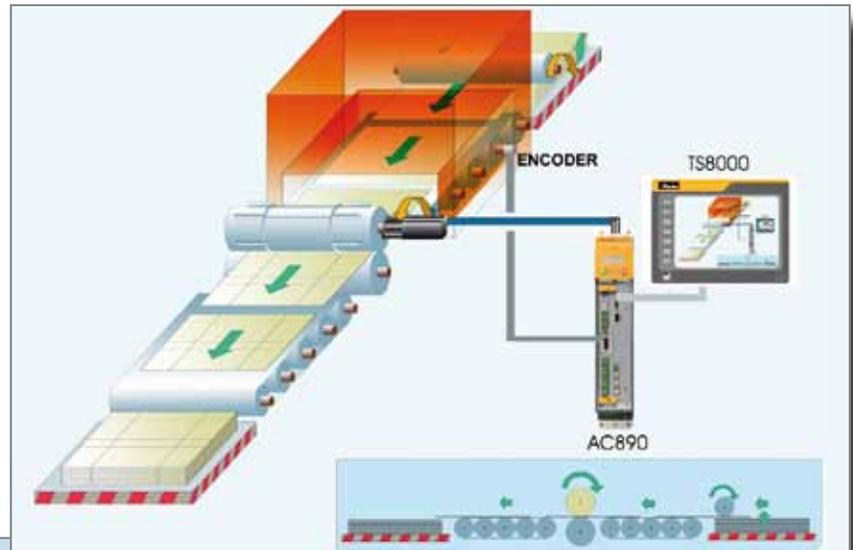

Communication Cards

TS8000 Series



Description

The TS8000 communication cards allow connection and integration of the TS8000 into many popular fieldbus communication networks.

Features

Configuration	by means of DSI8000 configuration software
Power Supply	Connection by pluggable 3-pin terminals
Operating Temperature	0 to 50°C
Storage Temperature	-20 to 80°C
Humidity	80% max. relative humidity (non-condensing) from 0 to 50°C
Altitude	2000 meters Max.

CANopen Communications Interface

Order Code: 8000/CB/00/00

Supported Protocols	CANopen SDO Master
Communication Speed	Selectable by software up to 1 Mbits/s
Communication	With Drive System Explorer software using RTNX protocol
Suitable for drives	AC890 version 3.2+

DeviceNet Communications Interface

Order Code: 8000/DN/00/00

Supported Protocols	DeviceNet – Slave Group 2 only
Communication Speed	Selectable by software up to 500 kbits/s

Firewire Communications Interface

Order Code: 8000/FA/00/00

This card allows data exchange between the TS8000 and an AC890 fitted with an 8903/FA/00 Interface

Communication Ports	Port A : IEEE 1394A Port B : IEEE 1394B
---------------------	--

Note : The TS8000 must use a Class 2 or SELV rated power supply

Link Communications Interface

Order Code: 8000/LK/00/00

Supported Protocols	LINK
Communication Speed	2.7Mbits/s

Allows data exchange between TS8000 and SSD LINK fiber optic network

Profibus-DP Communications Interface

Order Code: 8000/PB/00/00

Supported Protocols	EN50 170, 1
Communication Speed	Up to 12 Mbits/s

EMC Filters

for AC690+ Drives

Description

A range of pre-selected EMC (Electromagnetic Compatibility)/RFI (Radio Frequency Interference) Filters are available, suitable for all drives. These filters are a cost effective and easily implemented solution for the abatement of EMC in order to meet certain directives. Installation of the drive must be in accordance with the installation guidelines in the product manual.

Filters described as “footprint” type are designed to save panel space by mounting behind the drive.



Drive mounted on a “footprint” filter

Ordering

Part Number	Rating	Type	Description
Add “F” in Part Number	Per drive rating	Internal	Filter for Frame B AC690+ Drive
CO467842U020	20A	Footprint	Filter for Frame B AC690+ Drive
CO467842U044	40A	Footprint	Filter for Frame C AC690+/AC650V
CO467842U084	84A	Footprint	Filter for Frame D AC690+/AC650V Drive
CO467842U105	105A	Footprint	Filter for Frame E AC690+/AC650V/AC890SD Drive
CO467842U215	215A	Footprint	Filter for Frame F AC690+/AC650V/AC890SD Drive
CO467843U340	340A	External	Filter for Frame G, H or J AC690+/AC890SD Drive
CO467844U015	15A	External	EMC Filter for DC590+ Drive
CO467844U040	35, 40A	External	EMC Filter for DC590+ Drive
CO467844U070	70A	External	EMC Filter for DC590+ Drive
CO467844U110	110A	External	EMC Filter for DC590+ Drive
CO467844U165	165A	External	EMC Filter for DC590+ Drive
CO467844U180	180A	External	EMC Filter for DC590+ Drive
CO467844U340	270A	External	EMC Filter for DC590+ Drive
CO467844U340 (2 req’d)	360A, 500A	External	EMC Filter for DC590+ Drive
CO467844U340 (3 req’d)	720A, 830A	External	EMC Filter for DC590+ Drive
LA048357	N/A	External	Line filter for DC590+ Drive, 460V
LA353827	N/A	External	Fuse kit for LA048357 line filter

Three phase reactors

for AC690+ Drives

Description

Parker's range of reactors have been especially selected to match the requirements of the Parker AC drive range and can be used on either the input or output sides of the drive. They are used to add inductance to reduce the harmonic content of the supply current. A reactor installed in the drive output limits the capacitive current when motor cable runs in excess of 50m are used. It prevents overcurrent trips and temperature rise of the motor.

In addition to helping with compliance with IEEE 519 there are other benefits to using line/load reactors including:

- Increased drive system reliability
- Reduced harmonics / surge currents
- Reduced motor noise and temperature
- Improved true power factor

Ordering

Part Number	Line Voltage	Current	Drive HP (CT)	Impedance
CO470653	230	4A	1	3mH
CO353011		8A	1.5 / 2	1.5mH
CO470638		12A	3	1.25mH
CO353012		18A	5	0.8mH
CO353013		25A	7.5	0.5mH
CO353014		35A	10	0.4mH
CO353015		45A	15	0.3mH
CO353016		55A	20	0.25mH
CO353017		80A	25 / 30	0.20mH
CO470654		100A	40	0.15mH
CO353018		130A	50	0.1mH
CO471264		160A	60	0.075mH
CO470650		460	2A	1
CO470651	4A		2	6.5mH
CO352782	8A		3	5mH
CO470652	8A		5	3mH
CO352783	12A		7.5	2.5mH
CO352785	18A		10	1.5mH
CO352786	25A		15	1.2mH
CO352901	35A		20 / 25	0.8mH
CO352902	45A		30	0.7mH
CO352903	55A		40	0.5mH
CO352904	80A		50 / 60	0.4mH
CO352905	100A		75	0.3mH
CO352906	130A		100	0.3mH
CO470057	160A		125	0.15mH
CO470045	200A		150	0.11mH
CO470046	250A		200	0.09mH
CO470047	320A		250	0.075mH
CO470048	400A	300	0.06mH	
CO470049	500A	350 / 400	0.05mH	
CO470050	600A	500	0.04mH	



Grid Tie Inverters

for Renewable Energy



Description

One of the most important processes in any **photovoltaic (PV) solar** installation is the efficient conversion of energy generated by the arrays to a form that is compatible with the power grid. Parker SSD offers competitive solutions for every phase of solar energy – from a stand-alone grid tie inverter to a complete site-ready central station with battery storage. The combination of a highly efficient IGBT inverter design and MPP tracking makes for an energy recovery system that helps you squeeze the most out of each hour of sunlight.

In a typical **wind turbine** application, the blades rotate an induction or permanent magnet generator, either directly coupled or through a gear train. The speed of the generator will vary with wind velocity. Parker grid tie inverters effectively capture and smoothly distribute this newly generated power onto the power grid, synchronized to grid frequency at a constant 60 Hertz, regardless of wind velocity. Our inverter design has the ability to control the generator's torque and speed, and will optimize the loading of the generator to produce a constant output under fluctuating wind conditions. Integral harmonic filters ensure grid compliance by delivering pure sine wave power well within IEEE519 guidelines for Total Harmonic Distortion (THD). The efficiency of the inverter exceeds 98%, and provides a unity power factor. One properly sized AFE can support multiple inverters/generators each connected to the DC bus as one common system.

Oceans represent more than 70% of the earth's surface, but until now remained a largely untapped source of renewable energy. Parker SSD is helping to commercialize **wave power** extraction techniques that convert the waves' inconsistent flow into stable and constant power suitable for distribution to the grid.

Parker is an innovator in the field of utility scale **Energy Storage** solutions. Parker has partnered with the most advanced battery technology providers to supply utility scale grid-tied storage systems suitable for grid frequency stabilization, peak shaving, and VAR control. Among our successful installations is a 32 megawatt PCS with lithium ion batteries as the storage element.

www.parker.com/griddie

Mobile Hardened Drives

for Hybrid and Electric Vehicles



Description

Based on robust IGBT power platforms, Parker manufactures **Mobile Hardened Inverters and Converters** for a wide range of mobile sub-systems. Applications include traction, generator APU, implement drives, export power, and auxiliary drives. Drives can be provided in heavy duty weather-tight enclosures to IP67 standards, and with automotive duty connectors to expedite installation and change-out. Air cooling, liquid cooling (water/glycol or hydraulic fluid), or an advanced 2-phase refrigerant cooling system are among the options available. Five pre-engineered frame sizes cover the wide range of common requirements, from 5 kW to 300 kW. Both AC induction and PMAC motors are compatible with these drives, and are compatible with a broad range of feedback devices. DC bus voltages through 1000 volts can be accommodated.

Motors are also available to cover the same applications and power ranges of the inverter line. Air and liquid cooled variants are offered, depending upon the size and required duty of the motor. This family also includes generators, which are an essential part of the auxiliary power unit (APU) in a series hybrid design.

Mobile electric and hybrid electric platforms require a substantial amount of **energy storage**, especially where engine-off operation of implements or export power is required. We provide pre-engineered mobile hardened battery racks, using a variety of standard cell types from traditional lead-acid to advanced Lithium Ion. A battery management system (BMS) ensures safety and battery longevity, and can be included in these energy storage units.

Applications such as front-end loaders, excavators, and aerial lift trucks require hydraulics for the operation of implements, satisfying anti-idling laws and the desire to reduce fuel consumption and emissions. Combining Parker's expertise in hydraulics, motors, and electronics results in an efficient and flexible solution, available from 10 kW to 100 kW.

hev.parker.com



AC Motors

Inverter and Vector Duty - Compatible with AC650/V, AC690+, AC890, AC890PX
1 - 500 HP

Description

Parker SSD can provide Inverter Duty and Vector Duty motors that let you get the most out of your drive. With your choice of a wide variety of frame styles, every rating includes specific features demanded by high performance drive applications.

Cast iron frames with totally enclosed non-ventilated construction are available for harsh environments, while compact laminated frame designs with forced ventilation can fit into the tightest spaces while providing 1000:1 constant torque speed range and excellent dynamic performance.

Not all motors are created equal. Don't settle for a re-rated constant speed motor for variable speed applications. All Parker SSD Inverter and Vector Duty motors are provided with insulation that is suitable for use with IGBT based PWM drives, and with 200% torque overload capability. Ask for a performance matched package every time.

RPM AC™ Product Features



The RPM AC™ series of AC motors was designed specifically for optimum inverter duty performance, and offers high performance over a wide speed range. The compact, square cross-section, laminated steel frame includes cast iron brackets with feet for maximum ruggedness and stability. The unique low inertia design allows fast acceleration and high dynamic response. And to assure long and reliable motor life, Corona-Free insulation is used on all RPM ACTM ratings.

- Unique square laminated steel frames (FL210 - L440)
- Most compact, lightest weight
- Cast iron feet and end brackets
- Wide constant HP range - 4:1 to 12:1 available
- Low inertia design for faster dynamic response
- Replace DC motors with minimal mechanical issues
- Corona free insulation system
- Force ventilated open and enclosed blower cooled frames

Available enclosures:

DPG-FV (Drip-Proof Guarded Force Ventilated) - IEC IP23/IC06. Motor cooling is provided by motor-mounted blower driven by an integrally mounted three-phase blower motor.

TEBC (Totally Enclosed Air-Over Blower-Cooled) - IEC IP44/IC416. In-line blower cooled motors incorporate unique integral air ducts in the frame, external to the windings. The integrally mounted, independently powered three phase blowers result in low noise levels over wide speed ranges.

TEFC (Totally Enclosed Fan-Cooled) - IEC IP44/IC411. Exterior surface cooled by external fan mounted on motor shaft.

Encoders: Motors above are available with an encoder suitable for use with Parker SSD AC drives. On some ratings, the encoder is an option, while on others it is provided as standard equipment. The standard encoder is a 1024 PPR quadrature style with mating connector. Please inquire if you have any special encoder requirements.

V*S Master™ Product Features



For applications in tougher environments, we offer V*S Master™, featuring cast iron frame and end shields. Overload is no problem, with 200% capability for 60 seconds. Corona-Free insulation and an insulated CE bearing extend lifetime.

- Cast iron frames and end brackets
- Corona free insulation system
- 200% overload torque for 1 minute
- Three thermostats
- Constant HP to 1.5 times base speed
- Class F insulation
- Stainless steel nameplate
- Re-greaseable bearings
- TEFC ratings provide continuous full load torque from 0 to base speed
- CSA certified and UL recognized

DC Motors for use with Parker SSD DC Drives can also be provided. Please discuss your requirement with your SSD Drives territory manager, or with your local Parker distributor.

NOTES

At Parker, we're guided by a relentless drive to help our customers become more productive and achieve higher levels of profitability by engineering the best systems for their requirements. It means looking at customer applications from many angles to find new ways to create value. Whatever the motion and control technology need, Parker has the experience, breadth of product and global reach to consistently deliver. No company knows more about motion and control technology than Parker. For further info call (800) C-PARKER



AEROSPACE

Key Markets

- Aircraft engines
- Business & general aviation
- Commercial transports
- Land-based weapons systems
- Military aircraft
- Missiles & launch vehicles
- Regional transports
- Unmanned aerial vehicles

Key Products

- Flight control systems & components
- Fluid conveyance systems
- Fluid metering delivery & atomization devices
- Fuel systems & components
- Hydraulic systems & components
- Inert nitrogen generating systems
- Pneumatic systems & components
- Wheels & brakes



CLIMATE CONTROL

Key Markets

- Agriculture
- Air conditioning
- Food, beverage & dairy
- Life sciences & medical
- Precision cooling
- Processing
- Transportation

Key Products

- CO² controls
- Electronic controllers
- Filter driers
- Hand shut-off valves
- Hose & fittings
- Pressure regulating valves
- Refrigerant distributors
- Safety relief valves
- Solenoid valves
- Thermostatic expansion valves



ELECTROMECHANICAL

Key Markets

- Aerospace
- Factory automation
- Food & beverage
- Life science & medical
- Machine tools
- Packaging machinery
- Paper machinery
- Plastics machinery & converting
- Primary metals
- Semiconductor & electronics
- Textile
- Wire & cable

Key Products

- AC/DC drives & systems
- Electric actuators
- Controllers
- Gantry robots
- Gearheads
- Human machine interfaces
- Industrial PCs
- Inverters
- Linear motors, slides and stages
- Precision stages
- Stepper motors
- Servo motors, drives & controls
- Structural extrusions



FILTRATION

Key Markets

- Food & beverage
- Industrial machinery
- Life sciences
- Marine
- Mobile equipment
- Oil & gas
- Power generation
- Process
- Transportation

Key Products

- Analytical gas generators
- Compressed air & gas filters
- Condition monitoring
- Engine air, fuel & oil filtration & systems
- Hydraulic, lubrication & coolant filters
- Process, chemical, water & microfiltration filters
- Nitrogen, hydrogen & zero air generators



FLUID & GAS HANDLING

Key Markets

- Aerospace
- Agriculture
- Bulk chemical handling
- Construction machinery
- Food & beverage
- Fuel & gas delivery
- Industrial machinery
- Mobile
- Oil & gas
- Transportation
- Welding

Key Products

- Brass fittings & valves
- Diagnostic equipment
- Fluid conveyance systems
- Industrial hose
- PTFE & PFA hose, tubing & plastic fittings
- Rubber & thermoplastic hose & couplings
- Tube fittings & adapters
- Quick disconnects



HYDRAULICS

Key Markets

- Aerospace
- Aerial lift
- Agriculture
- Construction machinery
- Forestry
- Industrial machinery
- Mining
- Oil & gas
- Power generation & energy
- Truck hydraulics

Key Products

- Diagnostic equipment
- Hydraulic cylinders
- Hydraulic motors & pumps
- Hydraulic systems
- Hydraulic valves & controls
- Power take-offs
- Rubber & thermoplastic hose & couplings
- Tube fittings & adapters
- Quick disconnects



PNEUMATICS

Key Markets

- Aerospace
- Conveyor & material handling
- Factory automation
- Food & beverage
- Life science & medical
- Machine tools
- Packaging machinery
- Transportation & automotive

Key Products

- Air preparation
- Compact cylinders
- Field bus valve systems
- Grippers
- Guided cylinders
- Manifolds
- Miniature fluidics
- Pneumatic accessories
- Pneumatic actuators & grippers
- Pneumatic valves and controls
- Rodless cylinders
- Rotary actuators
- Tie rod cylinders
- Vacuum generators, cups & sensors



PROCESS CONTROL

Key Markets

- Chemical & refining
- Food, beverage & dairy
- Medical & dental
- Microelectronics
- Oil & gas
- Power generation

Key Products

- Analytical sample conditioning products & systems
- Fluoropolymer chemical delivery fittings, valves & pumps
- High purity gas delivery fittings, valves & regulators
- Instrumentation fittings, valves & regulators
- Medium pressure fittings & valves
- Process control manifolds



SEALING & SHIELDING

Key Markets

- Aerospace
- Chemical processing
- Consumer
- Energy, oil & gas
- Fluid power
- General industrial
- Information technology
- Life sciences
- Military
- Semiconductor
- Telecommunications
- Transportation

Key Products

- Dynamic seals
- Elastomeric o-rings
- EMI shielding
- Extruded & precision-cut, fabricated elastomeric seals
- Homogeneous & inserted elastomeric shapes
- High temperature metal seals
- Metal & plastic retained composite seals
- Thermal management

ENGINEERING YOUR SUCCESS.

Parker Worldwide

AE – UAE, Dubai

Tel: +971 4 8127100
parker.me@parker.com

AR – Argentina, Buenos Aires

Tel: +54 3327 44 4129

AT – Austria, Wiener Neustadt

Tel: +43 (0)2622 23501-0
parker.austria@parker.com

AT – Eastern Europe, Wiener Neustadt

Tel: +43 (0)2622 23501 900
parker.easteurope@parker.com

AU – Australia, Castle Hill

Tel: +61 (0)2-9634 7777

AZ – Azerbaijan, Baku

Tel: +994 50 2233 458
parker.azerbaijan@parker.com

BE/LU – Belgium, Nivelles

Tel: +32 (0)67 280 900
parker.belgium@parker.com

BR – Brazil, Cachoeirinha RS

Tel: +55 51 3470 9144

BY – Belarus, Minsk

Tel: +375 17 209 9399
parker.belarus@parker.com

CA – Canada, Milton, Ontario

Tel: +1 905 693 3000

CH – Switzerland, Etoy

Tel: +41 (0)21 821 87 00
parker.switzerland@parker.com

CL – Chile, Santiago

Tel: +56 2 623 1216

CN – China, Shanghai

Tel: +86 21 2899 5000

CZ – Czech Republic, Klecany

Tel: +420 284 083 111
parker.czechrepublic@parker.com

DE – Germany, Kaarst

Tel: +49 (0)2131 4016 0
parker.germany@parker.com

DK – Denmark, Ballerup

Tel: +45 43 56 04 00
parker.denmark@parker.com

ES – Spain, Madrid

Tel: +34 902 330 001
parker.spain@parker.com

FI – Finland, Vantaa

Tel: +358 (0)20 753 2500
parker.finland@parker.com

FR – France, Contamine s/Arve

Tel: +33 (0)4 50 25 80 25
parker.france@parker.com

GR – Greece, Athens

Tel: +30 210 933 6450
parker.greece@parker.com

HK – Hong Kong

Tel: +852 2428 8008

HU – Hungary, Budapest

Tel: +36 1 220 4155
parker.hungary@parker.com

IE – Ireland, Dublin

Tel: +353 (0)1 466 6370
parker.ireland@parker.com

IN – India, Mumbai

Tel: +91 22 6513 7081-85

IT – Italy, Corsico (MI)

Tel: +39 02 45 19 21
parker.italy@parker.com

JP – Japan, Tokyo

Tel: +81 (0)3 6408 3901

KR – South Korea, Seoul

Tel: +82 2 559 0400

KZ – Kazakhstan, Almaty

Tel: +7 7272 505 800
parker.easteurope@parker.com

LV – Latvia, Riga

Tel: +371 6 745 2601
parker.latvia@parker.com

MX – Mexico, Apodaca

Tel: +52 81 8156 6000

MY – Malaysia, Shah Alam

Tel: +60 3 7849 0800

NL – The Netherlands, Oldenzaal

Tel: +31 (0)541 585 000
parker.nl@parker.com

NO – Norway, Ski

Tel: +47 64 91 10 00
parker.norway@parker.com

NZ – New Zealand, Mt Wellington

Tel: +64 9 574 1744

PL – Poland, Warsaw

Tel: +48 (0)22 573 24 00
parker.poland@parker.com

PT – Portugal, Leca da Palmeira

Tel: +351 22 999 7360
parker.portugal@parker.com

RO – Romania, Bucharest

Tel: +40 21 252 1382
parker.romania@parker.com

RU – Russia, Moscow

Tel: +7 495 645-2156
parker.russia@parker.com

SE – Sweden, Spånga

Tel: +46 (0)8 59 79 50 00
parker.sweden@parker.com

SG – Singapore

Tel: +65 6887 6300

SK – Slovakia, Banská Bystrica

Tel: +421 484 162 252
parker.slovakia@parker.com

SL – Slovenia, Novo Mesto

Tel: +386 7 337 6650
parker.slovenia@parker.com

TH – Thailand, Bangkok

Tel: +662 717 8140

TR – Turkey, Istanbul

Tel: +90 216 4997081
parker.turkey@parker.com

TW – Taiwan, Taipei

Tel: +886 2 2298 8987

UA – Ukraine, Kiev

Tel: +380 44 494 2731
parker.ukraine@parker.com

UK – United Kingdom, Warwick

Tel: +44 (0)1926 317 878
parker.uk@parker.com

US – USA, Cleveland

Tel: +1 216 896 3000

VE – Venezuela, Caracas

Tel: +58 212 238 5422

ZA – South Africa, Kempton Park

Tel: +27 (0)11 961 0700
parker.southafrica@parker.com

