

[www.Asakssystem.com](http://www.Asakssystem.com)

۸۸۸ ۴۴ ۳۷۰ - ۸۸۸ ۴۱ ۶۸۳



آساک سیستم

توزیع کلیه ملزومات و مواد مصرفی

دفاتر فنی و مراکز چاپ دیجیتال

• دستگاههای پلاتر و لمینیتور طولی

• کاغذ رول و شیت پلاتر و پرینتر

• هد، جوهر و قطعات پلاتر و پرینتر

• رول و شیت لمینیت سرد و گرم

• تونر طرح و فابریک دستگاههای کپی

• دستگاههای صحافی، سیمی و فنر

## SD-2501B21

### 2. The product specification table :

MODEL	SD-2501B21
Machine type	Comb type
Punching (80g/70g-A4/Sheets)	25/30
Binding (80g-A4/Sheets)	400
Hole size (mm)	3X8
Hole qty (pcs)	1- 21
Free pins (pcs)	21
Extra binding handle	YES
Margin (mm)	3, 6, 9
Size (mm)	430x400x250
Inner box (mm)	456x270x446
Carton (mm)	555X465X460
G.W. (kg)	15
PCS/Carton	2
20'/40'FCL (PCS)	480/1000

### 3. Trait:

With special strong steel punching handle

21 blades free pins for multi punching

Punching up to 25/30 sheets per time Max.

Binding up to 400 sheets A4 papers Max.

### 4. Functional components of Graphs:

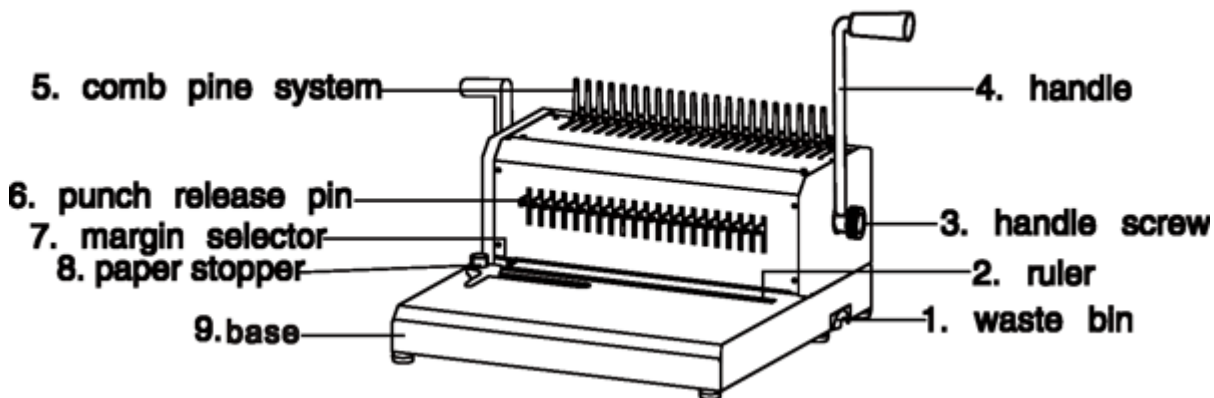

### 5. The product details:

#### 1. Installation:

a. Fasten the handle to the binding machine with handle screw correctly

b. Put the machine on the flat desk and, ensure the base is stable, then the machine is ready for work.

## 2. Attention :

- a. Do not punch over the punching capacity
- b. Do not punch wet paper, cloth, glass, metal material etc.
- c. Always clean the waste bin.
- d. Do not hit or drop to the comb pine system, or the personal damage will occur, for this reason.
- e. Do not expose the top of the machine, esp. the comb pine system to anybody, the machine should be put on a safety place.
- f. The machine is only for adult use, do not let the children to touch or operate.
- g. Do not disassemble the machine by yourself, please contact your professional service department or dealer in case of malfunction

## 3. Operation:

- a. Set the margin selector and the paper stopper on the reasonable position
- b. Punch the papers or the binding covers by pressing the handle downward
- c. Choose a correct binding ring by referring to the last page.
- d. Put the binding ring to the comb pine system; pull the handle upward to open the ring correctly

f. Insert the punched papers into comb rings properly; pull the handle

downward to close the ring so as to complete the binding.

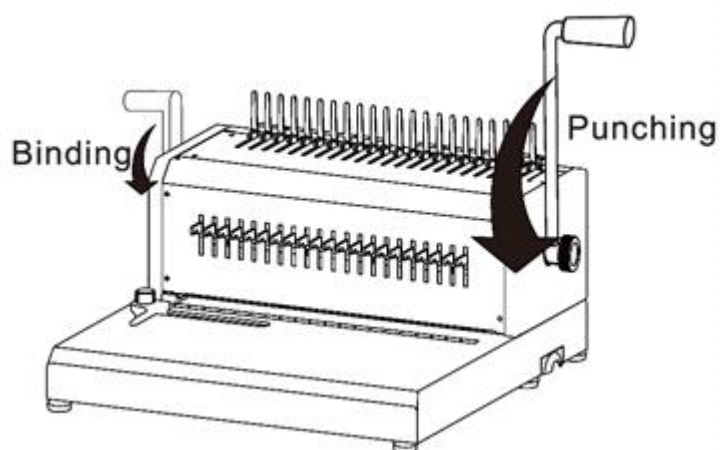

### Comb Binding Ring Selection:

Dinmension (mm)	No.of Sheets(80g)	Shape	Dinmension (mm)	No.of Sheets(80g)	Shape
6	2-20	Round	28	201-225	Oval
8	21-35	Round	32	226-250	Oval
10	36-45	Round	38	251-310	Oval
12	46-80	Round	45	311-360	Oval
14	81-100	Round	51	361-410	Oval
16	101-120	Round			
19	121-140	Round			
22	141-170	Round			
25	171-200	Round			