



OPTIMIX

2A 8-720

2A 15-720

2A 22-720



Application

Submersible motor
Dry matter content up to 4 %
Substrate temperature up to 55°C
pH-value 5.5 - 8.2

Propeller

3-blade high efficiency propeller, dynamically balanced, self-cleaning

Optimix 2A	0.8 kW	propeller LD 250 S	738 rpm
Optimix 2A	1.5 kW	propeller LD 320 S	728 rpm
Optimix 2A	2.2 kW	propeller LD 340 S	714 rpm

ss304, hardened ss304 or ss316

Motor

Motor power: 0.8 / 1.5 / 2.0 kW, 8-poles
230 / 400 V, 50 Hz, special tension on request
Protection class IP 68, up to 10 m submergence
PTC thermistors for overheat protection
High efficiency class
Own oil circulation, turbine oil

Guide mast connection

Guide mast support with 4 rollers for smooth height adjustment:
60 / 80 mm square mast
Special sizes on request

Bearing

Bearing flange with mechanical seal of SiC/SiC
Shaft of ss304
Bearing flange with separate oil chamber
Longlife oil
Accessory: POM protection to minimize abrasion

Corrosion protection

Guiding unit of ss304

Ex zone

Authorized for Ex-Zone 2
ATEX Classification **CE** **Ex** II 3G Ex ec h IIA T3 Gc

Electric cable

Standard length 10 m, with pressed-on cable gland
Microbe resistant cable 4 x 2.5 + 2 x 1 mm², Ø 20 mm
Strain relief 800 N



بیسارایزن پارس

نمایندگی ایران

تلفن تماس: ۸ و ۸۸۳۲۴۹۳۷ - ۰۲۱

E-mail: sales@brp.co.ir

OPTIMIX

2A 8-720

2A 15-720

2A 22-720

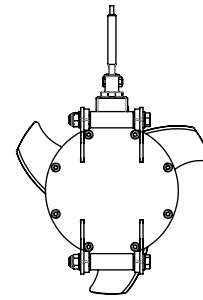
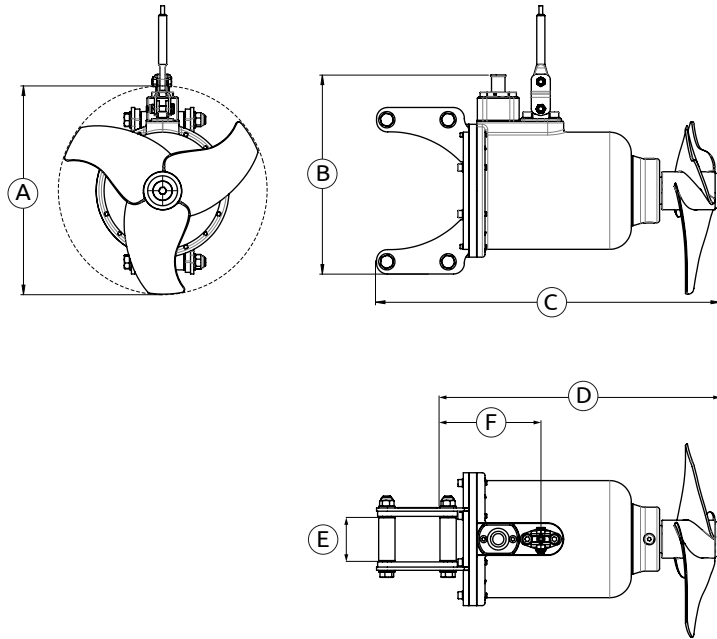

بیسارزین پارس

نماینده ایران

تلفن تماس : ۸ و ۸۸۳۲۴۹۳۷ - ۰۲۱

E-mail : sales@brp.co.ir

Dimensions / Weight

Type	A [Ø in mm]	B [mm]	C [mm]	D [mm]	E [mm]	F [mm]	Weight approx. [kg]			
2A 8-720	250	370	635	506	60 / 80	196	75			
2A 15-720	320	370	635	506	60 / 80	196	75			
2A 22-720	380	370	635	506	60 / 80	196	75			

Technical data

Type	Rated Power [kW]	Rated Voltage [V]	Full load current [A]	Frequency [Hz]	Power factor cos φ	Propeller speed [rpm]	Propeller diameter [mm]	Axial force [kN]	Flow velocity [m/s] *	Pumping rate [m ³ /min]	Pumping rate [m ³ /h]
2A 8-720	0.8	400	3.95	50	0.37	738	250	0.24	2.55	7	420
2A 15-720	1.5	400	4.7	50	0.56	728	320	0.43	2.92	13	800
2A 22-720	2.2	400	5.9	50	0.68	714	340	0.50	3.15	16	950

Subject to technical changes

* measured in water and 1.2 m distance

OPTIMIX

2A 30-710

2A 40-950

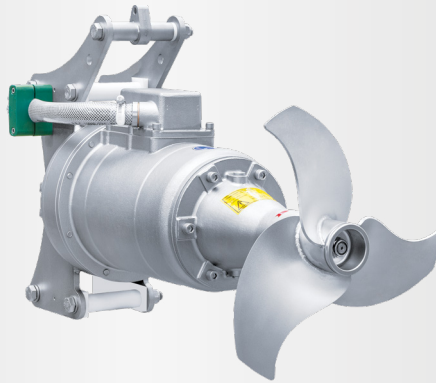

Application

Submersible motor
Dry matter content up to 8 %
Substrate temperature up to 55°C
pH-value 5.5 - 8.2 / optional ss316: pH-value 4.5 - 8.2

Motor

Motor power: 3.0 kW, 4.0 kW
400 V, 50 Hz, special tension on request
Protection class IP 68, up to 10 m submergence
PTC thermistors for overheat protection
Own oil circulation, turbine oil

Bearing

Bearing flange with mechanical seal of SiC/SiC
Two tapered roller bearings to absorb the axial forces
Shaft of ss304 / optional ss316
Bearing flange with separate oil chamber
Oil longlife

Ex zone (tube and bearing)

Authorized for Ex-Zone 2
ATEX Classification $\text{CE} \text{ II 3G Ex ec h IIA T3 Gc}$

Propeller

3-blade high efficiency propeller, dynamically balanced

Optimix 2A	3.0 kW	propeller LD 380	710 rpm
Optimix 2A	4.0 kW	propeller LD 310	950 rpm

Galvanized, hardened steel, ss304 or hardened ss304

Guide mast connection

Guide mast support with 4 rollers for smooth height adjustment:
80 / 100 / 120 mm square mast
Special sizes on request

Corrosion protection

Guiding unit of ss304
Optional completely of ss316

Electric cable

Standard length 10 m, with pressed-on cable gland
Microbe resistant cable $4 \times 2.5 + 2 \times 1 \text{ mm}^2$, $\varnothing 20 \text{ mm}$
Strain relief 800 N

Control box (optional)

soft start or frequency converter



سینا زارین پارس
نماینده گی ایران

تلفن تماس: ۸ و ۸۸۳۲۴۹۳۷ - ۰۲۱

E-mail: sales@brp.co.ir

OPTIMIX

2A 30-710

2A 40-950

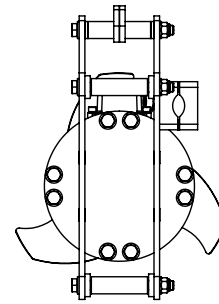
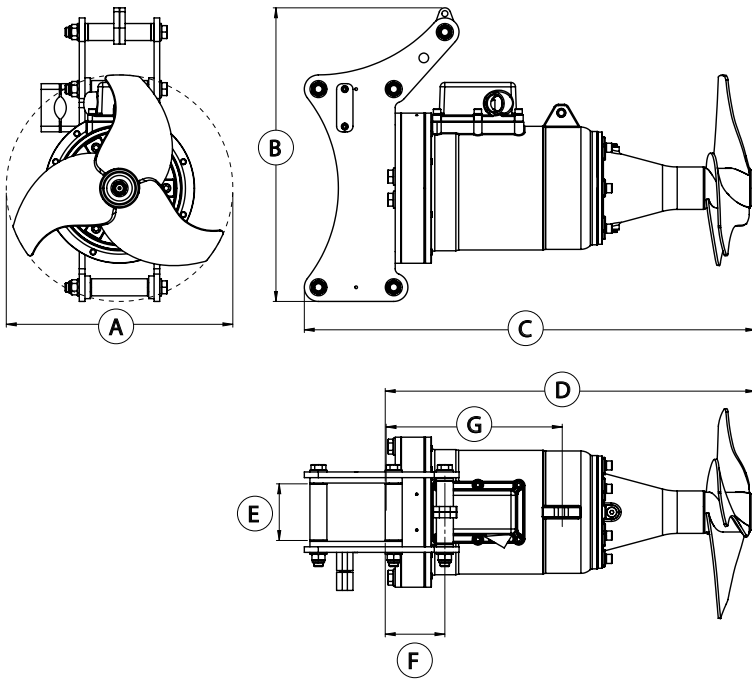

نمایندگی ایران

تلفن تماس: ۸ و ۸۸۳۲۴۹۲۷ - ۰۲۱

E-mail: sales@brp.co.ir

Dimensions / Weight

Type	A [∅ in mm]	B [mm]	C [mm]	D [mm]	E [mm]	F [mm]	G [mm]	Weight approx. [kg]
2A 30-710	380	520	800	650	80 / 100 / 120	105	310	150
2A 40-950	310	520	800	650	80 / 100 / 120	105	310	150

Technical data

Type	Rated Power [kW]	Rated Voltage [V]	Full load current [A]	Frequency [Hz]	Power factor cos φ	Propeller speed [rpm]	Propeller diameter [mm]	Axial force [kN]	Flow velocity [m/s] *	Pumping rate [m ³ /min]	Pumping rate [m ³ /h]
2A 30-710	3.0	400	7.8	50	0.68	710	380	0.7	3.6	24	1,420
2A 40-950	4.0	400	8.6	50	0.79	950	310	0.7	3.0	13	770

Subject to technical changes

* measured in water and 1.2 m distance

OPTIMIX

2A 40-180

2A 40-250



Application

Submersible motor
 Dry matter content up to 12 %
 Substrate temperature up to 55°C
 pH-value 5.5 - 8.2 / optional pH-values ss316 4.5-8.2

Motor

Motor power: 4.0 kW
 400V, 50Hz, special tensions on request
 Protection class IP 68, up to 10 m submergence
 PTC thermistors for thermal protection
 Separat oil chamber, turbine oil

Gear

Flange mounted planetary gear
 Reduction ratio $i = 3.83 / 5.25$
 Seperate oil chamber, longlife gear oil
 Change oil after 10,000 operating hours

Corrosion protection

Housing and guiding unit in ss304
 Optional completely manufactured in ss316

Electric Cable

Pressed cable gland, cable standard length 10 m
 Cable 7 x 4 + 4 x 1 mm² Ø 20 mm, shielded
 Resistant against biomass microbes
 Strain relief 800 N

Propeller

3-blade propeller, dynamically balanced

Optimix 2A	4 kW	propeller HD+700	180 rpm
Optimix 2A	4 kW	propeller HD+620	250 rpm

ss304, hardened ss304 or ss316

Guide mast connection

Guide mast support with 4 rollers for smooth height adjustment:
 80 / 100 / 120 mm square mast
 Special sizes on request

Bearing

Bearing flange with mechanical seal SiC/SiC
 2 tapered roller bearings to absorb the axial forces
 Shaft in hardened steel
 Separat oil chamber, longlife gear oil
Accessory: POM protection to minimize abrasion

Ex zone

Authorized for Ex-Zone 2
 ATEX Classification **CE**  II 3G Ex ec h IIA T3 Gc

Control box (optional)

Star-delta-switch, soft start or frequency converter



بیسمارکین پارس

نمایندگی ایران

تلفن تماس : ۸ و ۸۸۳۲۴۹۳۷ - ۰۲۱

E-mail : sales@brp.co.ir

OPTIMIX

2A 40-180

2A 40-250

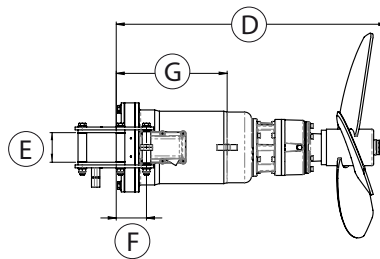
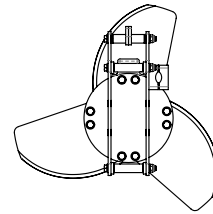
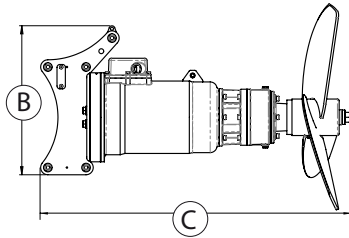
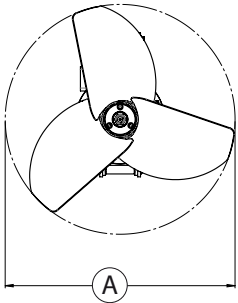

نمایندگی ایران

تلفن تماس: ۸ و ۸۸۳۲۴۹۲۷ - ۰۲۱

E-mail: sales@brp.co.ir

Dimensions / Weight

Type	A [∅ in mm]	B [mm]	C [mm]	D [mm]	E [mm]	F [mm]	G [mm]	Weight approx. [kg]			
2A 40-180	700	520	1,085	890	80 / 100 / 120	105	305	170			
2A 40-250	620	520	1,050	855	80 / 100 / 120	105	305	170			

Technical data

Type	Rated Power [kW]	Rated Voltage [V]	Full load current [A]	Frequency [Hz]	Power factor cos φ	Gear reduction ratio	Propeller speed [rpm]	Propeller diameter [mm]	Axial force [kN]	Flow velocity [m/s] *	Pumping rate [m³/min]	Pumping rate [m³/h]
2A 40-180	4.0	400	8.8	50	0.77	5.25	180	700	0.85	2.0	45	2,680
2A 40-250	4.0	400	8.8	50	0.77	3.83	250	620	0.95	2.2	38	2,290

Subject to technical changes

* measured in water and 1.2 m distance

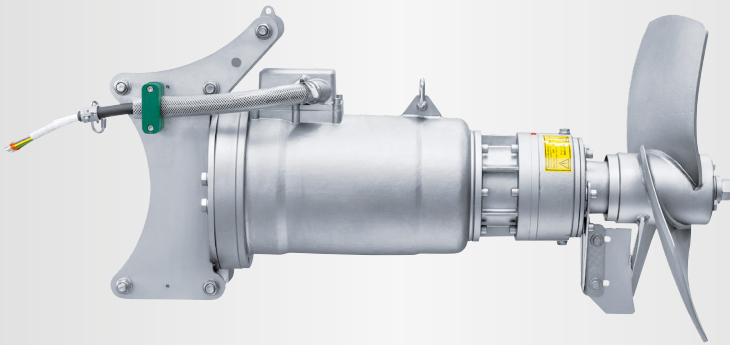

OPTIMIX

2A 90-280

2A 90-380



Application

Submersible motor
 Dry matter content up to 12 %
 Substrate temperature up to 55°C
 pH-value 5.5 - 8.2 / optional ss316 pH-value 4.5-8.2

Motor

Power: 9.0 kW
 400 V, 50 Hz, special tension on request
 Protection class IP 68, up to 10 m submergence
 PTC thermistors in as overheat protection
 Own oil circulation, turbine oil

Gear

Robust planetary gear,
 Reduction ratio $i = 3.83 / 5.25$
 Own oil circulation, Longlife gear oil
 Change oil after 10,000 operating hours

Bearing

Bearing flange with mechanical seal of SiC/SiC
 2 tapered roller bearings to absorb the axial forces
 Drive head with separat oil chamber
 Longlife Gear oil
Accessory: POM protection to minimize abrasion

Ex-Zone

Authorized for Ex-Zone 2
 ATEX Classification $\text{CE Ex II 3G Ex ec h IIA T3 Gc}$

Propeller

3-blade high efficiency propeller, dynamically balanced

Optimix 2A	9.0 kW	propeller HD+800	280 rpm
Optimix 2A	9.0 kW	propeller HD+580	380 rpm

ss304, ss304 hardened or ss316

Guiding unit

Guide mast support with 4 rollers for smooth height adjustment:
 for 9 kW: 100 / 120 mm square mast
 Special sizes on request

Corrosion protection

Guiding unit in ss304
 Optional completely in ss316

Cable

Pressed-on cable gland
 Cable $7 \times 4 + 4 \times 1.0 \text{ mm}^2$, $\varnothing 20 \text{ mm}$, shielded
 Microbe resistant
 Strain relief 800 N

Control box (optional)

Star-delta switch, soft start or frequency converter



بیمتازین پارس

نمایندگی ایران

تلفن تماس: ۸ و ۰۲۱ - ۸۸۳۲۴۹۳۷

OPTIMIX

2A 90-280

2A 90-380

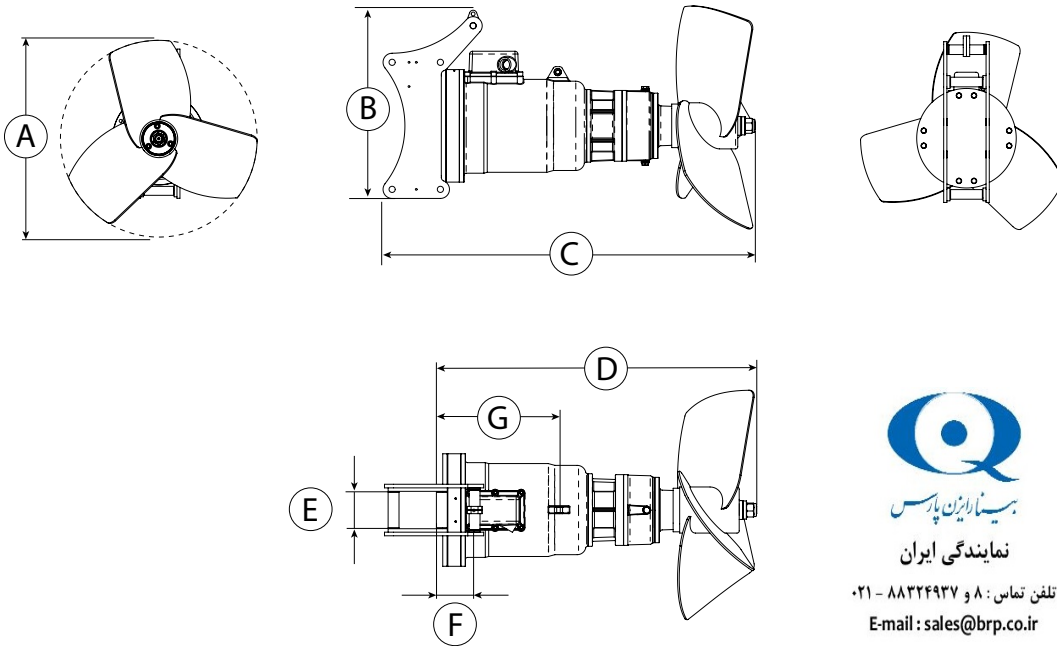

بیستادارین پارس

 نمایندگی ایران

 تلفن تماس: ۸ و ۸۸۳۲۴۹۳۷ - ۰۲۱

 E-mail: sales@brp.co.ir

Dimensions / Weight

Type	A [mm]	B [mm]	C max [mm]	D [mm]	E [mm]	F [mm]	G [mm]	Weight approx. [kg]			
2A 90-280	750	520	1,085	885	100 / 120	105	300	170			
2A 90-380	580	520	1,050	850	100 / 120	105	300	170			

Technical data

Type	Rated Power [kW]	Rated Voltage [V]	Full load current [A]	Frequency [Hz]	Power factor cos ϕ	Gear reduction ratio	Propeller speed [rpm]	Propeller diameter [mm]	Axial force [kN]	Flow velocity [m/s] *	Pumping rate [m ³ /min]	Pumping rate [m ³ /h]
2A 90-280	9.0	400	17.7	50	0.83	5.25	280	800	2.8	3.2	94	5.640
2A 90-380	9.0	400	17.7	50	0.83	3.83	380	580	1.9	3.4	51	3.080

Subject to technical changes
 * measured in water and 1.2 m distance

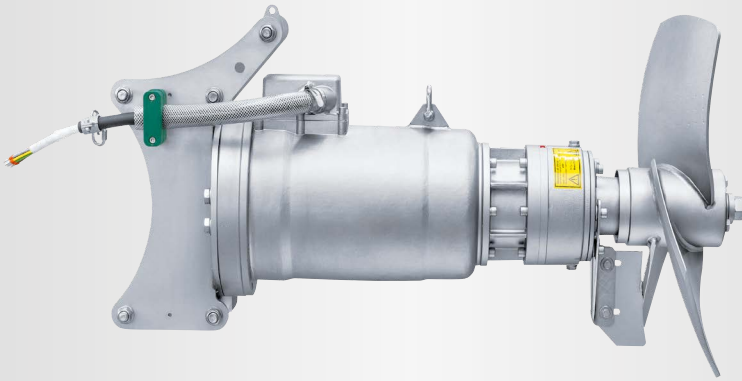

OPTIMIX

2A 150-280

2A 150-380



Application

Submersible motor for aggressive media with low pH-values
 Dry matter content up to 12 %
 Substrate temperature up to 52°C
 pH-values 5.5 - 8.2 / optional ss316 pH-values 4.5 - 8.2

Propeller

3-blade propeller, dynamically balanced

Optimix 2A	15 kW	propeller HD+850	280 rpm
Optimix 2A	15 kW	propeller HD+660	380 rpm

ss304, hardened ss304 or ss316

Motor

Motor power: 15.0 kW
 400V, 50Hz, special tensions on request
 Protection class IP 68, up to 10 m submergence
 PTC thermistors for thermal protection
 Separat oil chamber, turbine oil

Guide mast connection

Guide mast support with 4 rollers for smooth height adjustment:
 15.0 kW: 100 / 120 / 150 mm square mast
 Special sizes on request

Gear

Flange mounted planetary gear
 Reduction ratio $i = 5.25$ or 3.83
 Longlife gear oil
 Change oil after 8,000 operating hours,
 or after 4,000 operating hours for 2A 150-380

Bearing

Bearing flange with mechanical seal SiC/SiC
 2 tapered roller bearings to absorb the axial forces
 Shaft in hardened steel
 Separat oil chamber, longlife gear oil
Accessory: POM protection to minimize abrasion

Electric Cable

Pressed cable gland, cable standard length 10 m
 Cable 7 x 4 + 4 x 1 mm² Ø 20 mm, shielded
 Resistant against biomass microbes
 Strain relief 800 N

Ex zone

Authorized for Ex-Zone 2
 CE Ex II 3G Ex ec h IIA T3 Gc

Corrosion protection

Housing and guiding unit in ss304
 Optional completely manufactured in ss316

Control box (optional)

Soft start or frequency converter



تلفن تماس : ۸ و ۸۸۲۴۹۳۷ - ۰۲۱

E-mail : sales@brp.co.ir

OPTIMIX

2A 150-280

2A 150-380

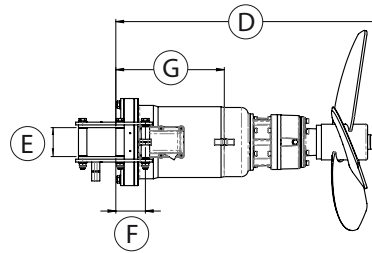
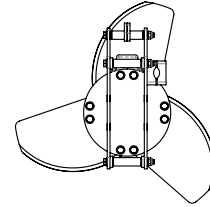
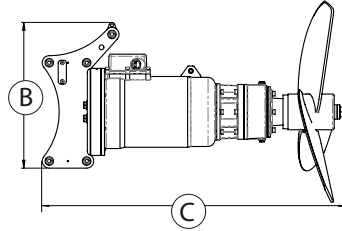
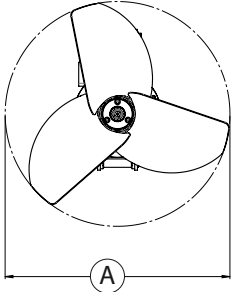

بسیارترین پارس

نماینده گی ایران

تلفن تماس: ۸ و ۰۲۱ - ۸۸۳۲۴۹۳۷

E-mail: sales@brp.co.ir

Dimensions

Type	A [Ø in mm]	B [mm]	C [mm]	D [mm]	E [mm]	F [mm]	G [mm]	Weight approx. [kg]			
2A 150-280	850	520	1.195	995	100 / 120 / 150	105	385	190			
2A 150-380	660	520	1.160	960	100 / 120 / 150	105	385	190			

Technical data

Type	Rated Power [kW]	Rated Voltage [V]	Full load current [A]	Frequency [Hz]	Power factor cos φ	Gear reduction ratio	Propeller speed [rpm]	Propeller diameter [mm]	Axial force [kN]	Flow velocity [m/s] *	Pumping rate [m³/min]	Pumping rate [m³/h]
2A 150-280	15.0	400	27	50	0.91	5.25	280	850	4.1	3.6	120	7.190
2A 150-380	15.0	400	27	50	0.91	3.83	380	660	3.1	4.1	81	4.860

Subject to technical changes

* measured in water and 1.2 m distance

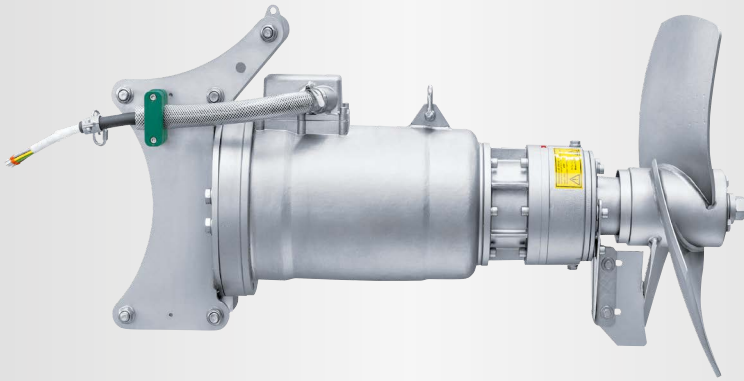

OPTIMIX

2A 135-280

2A 135-380



Application

Submersible motor for ex-zone 1 or aggressive media with low pH-values
 Dry matter content up to 12 %
 Substrate temperature up to 52°C
 pH-values 5.5 - 8.2 / optional ss316 pH-values 4.5 - 8.2

Motor

Motor power: 13.5 kW
 400V, 50Hz, special tensions on request
 Protection class IP 68, up to 10 m submergence
 PTC thermistors for thermal protection
 Separat oil chamber, turbine oil

Gear

Flange mounted planetary gear
 Reduction ratio $i = 5.25$ or 3.83
 Longlife gear oil
 Change oil after 4,000 operating hours

Electric Cable

Pressed cable gland, cable standard length 10 m
 Cable $7 \times 4 + 4 \times 1 \text{ mm}^2 \text{ } \varnothing 20 \text{ mm}$, shielded
 Resistant against biomass microbes
 Strain relief 800 N

Corrosion protection

Housing and guiding unit in ss304
 Optional completely manufactured in ss316

Propeller

3-blade propeller, dynamically balanced

Optimix 2A	13.5 kW	propeller HD+800	280 rpm
Optimix 2A	13.5 kW	propeller HD+620	380 rpm

ss304, hardened ss304 or ss316

Guide mast connection

Guide mast support with 4 rollers for smooth height adjustment:
 13.5 kW: 100 / 120 / 150 mm square mast
 Special sizes on request

Bearing

Bearing flange with mechanical seal SiC/SiC
 2 tapered roller bearings to absorb the axial forces
 Shaft in hardened steel
 Separat oil chamber, longlife gear oil
Accessory: POM protection to minimize abrasion

Ex zone

Authorized for Ex-Zone 1
 CE Ex II 2G Ex eb h IIA T3 Gb

Control box (optional)

Soft start or frequency converter



تلفن تماس: ۸ و ۸۸۳۲۴۹۳۷ - ۰۲۱

E-mail: sales@brp.co.ir

OPTIMIX

2A 135-280

2A 135-380

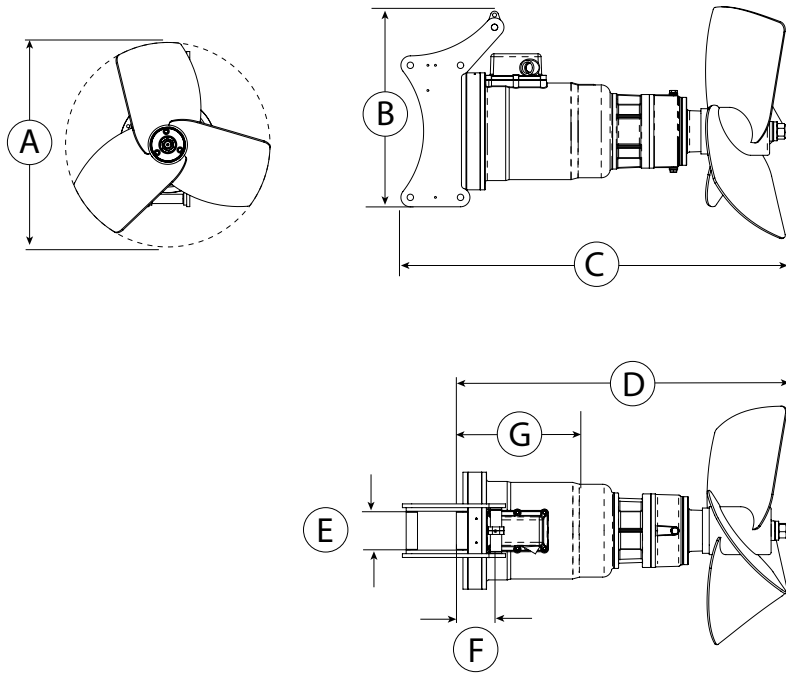
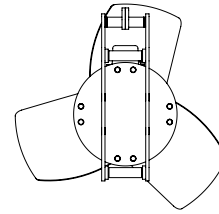

بیسارایزین پارس

نماینده گی ایران

تلفن تماس: ۸ و ۸۸۲۲۴۹۳۷ - ۰۲۱

E-mail : sales@brp.co.ir

Dimensions / Weight

Type	A [Ø in mm]	B [mm]	C [mm]	D [mm]	E [mm]	F [mm]	G [mm]	Weight approx. [kg]			
2A 135-280	800	520	1,195	995	100 / 120 / 150	105	385	190			
2A 135-380	620	520	1,160	960	100 / 120 / 150	105	385	190			

Technical data

Type	Rated Power [kW]	Rated Voltage [V]	Full load current [A]	Frequency [Hz]	Power factor cos φ	Gear reduction ratio	Propeller speed [rpm]	Propeller diameter [mm]	Axial force [kN]	Flow velocity [m/s] *	Pumping rate [m³/min]	Pumping rate [m³/h]
2A 135-280	13.5	400	24	50	0.90	5.25	280	800	2.9	3.2	94	5.640
2A 135-380	13.5	400	24	50	0.90	3.83	380	620	2.55	3.7	64	3.850

Subject to technical changes

* measured in water and 1.2 m distance