

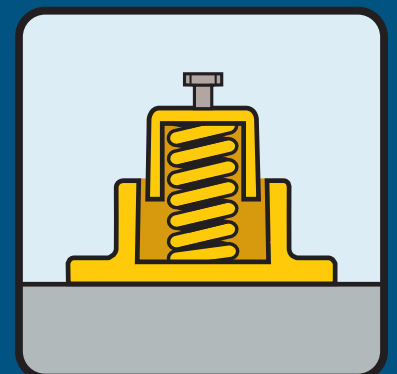

Standard Type Spring Units



Spring Units with and without Damping, for Loads up to 57 kN (5.7 t, 12,800 lbf)

Vibration isolating a machine means to reduce significantly any transmission of shock type, transient type or periodic type dynamic forces into the surroundings.

Spring units belonging to our standard program may be selected from the following tables for all machines which cause small dynamic forces compared to the total weight of the machine, e.g. wellbalanced rotating machines or massbalanced compressors. All listed spring units are available on short notice ex works GERB Berlin. Spring units of this program consist of cast iron made lower and upper

casings containing one or more helical compression springs. Spring units are delivered with a high quality painting (standard colour: yellow, RAL 1004). On special request these spring units are available also in welded steel casings.

The spring units are designed for load capacities from 0.12 to 57 kN (12 to 5,700 kg, 27 to 12,800 lbf) and can readily be supplied for mounting with or without damping (Viscodamping® or Sordino-damping). Damping might increase spring constants and natural frequencies of the spring units.

GERB spring units may be fixed with bolts, but in most cases our 4 mm thick resilient pads will provide safe fixing.

For higher vertical loads and for low speed GERB supplies spring units of special design with load capacities of up to 3,000 kN (300 tons, 675 kips).

Our technical offices would appreciate to give you all required support regarding selection of spring units and the GERB range of activities. Please contact your nearest GERB office or send a mail to info@gerb.de.

S1

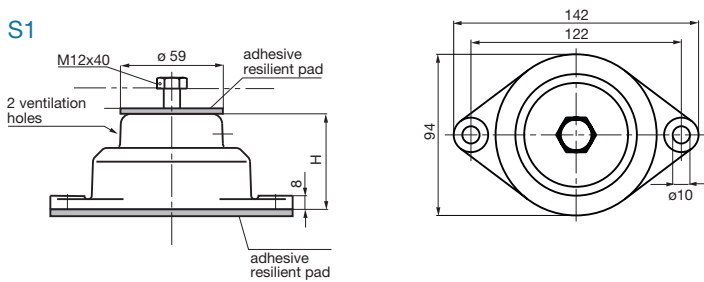

Spring unit type S1

type	load capacity (N)		vertical spring constant (N/mm)	vertical natural frequency		height (H in mm)		
	from	to		from	to	at delivery	from	loaded to
S1-11	120	270	11	4.8	3.2	56	53	40
S1-12	200	460	19	4.8	3.2	56	53	40
S1-13	300	610	28	4.8	3.4	56	53	42
S1-14	510	1070	64	5.6	3.9	56	53	44

This type can be supplied with height adjustment and/or damping.

S2

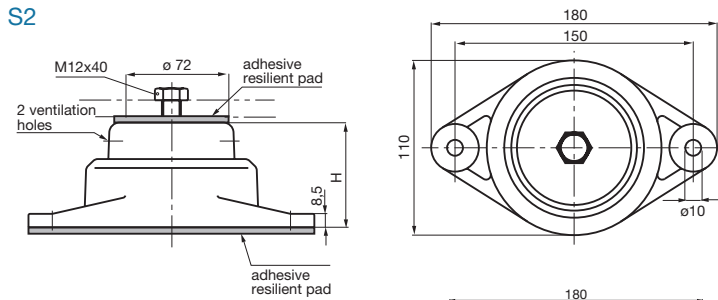

Spring unit type S2

type	load capacity (N)		vertical spring constant (N/mm)	vertical natural frequency (Hz)		height (H in mm)		
	from	to		from	to	at delivery	from	loaded to
S2-41	550	1450	69	5.6	3.5	66	63	50
S2-42	560	1500	81	6.0	3.7	66	62	51
S2-43	670	1810	97	6.0	3.7	66	62	50
S2-44	810	1920	118	6.0	3.9	66	62	53
S2-45	980	1980	142	6.0	4.2	66	62	55
S2-46	1200	2430	173	6.0	4.2	66	62	55
S2-47	1380	2840	200	6.0	4.2	66	62	55
S2-48	1680	3310	243	6.0	4.3	66	61	54

This type can be supplied with height adjustment and/or damping.

S3

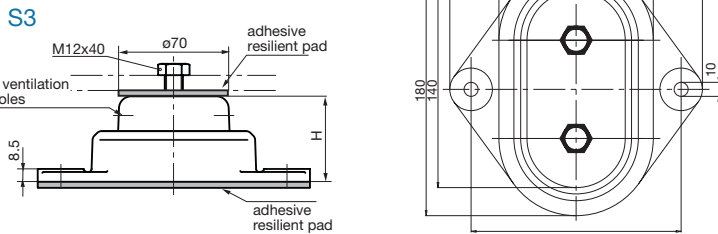

Spring unit type S3, S3Q

type	load capacity (N)		vertical spring constant (N/mm)	vertical natural frequency (Hz)		height (H in mm)		
	from	to		from	to	at delivery	from	loaded to
S3-241	1240	2890	138	5.3	3.5	66	63	51
S3-242	1290	2990	162	5.6	3.7	66	63	53
S3-243	1330	3610	194	6.0	3.7	66	62	50
S3-244	1620	3830	236	6.0	3.9	66	62	53
S3-245	1950	3950	284	6.0	4.2	66	62	55
S3-246	2380	4850	346	6.0	4.2	66	62	55
S3-247	2760	5680	400	6.0	4.2	66	62	55
S3-248	3350	6610	486	6.0	4.3	66	61	54

This type can be supplied with damping.

S3Q

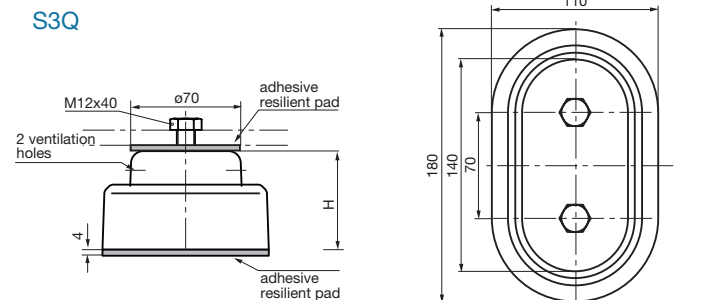



Spring unit type D1

type	load capacity (N)		vertical spring constant (N/mm)	vertical natural frequency (Hz)		height (H in mm)		
	from	to		from	to	at delivery	from	loaded
D1-31	100	650	15	6.0	2.4	114	110	74
D1-32	180	1080	27	6.0	2.5	114	108	75
D1-33	260	1420	35	5.8	2.5	114	111	78
D1-34	520	2300	75	6.0	2.9	114	108	84
D1-35	1000	2990	145	6.0	3.5	114	108	94
D1-81	1670	4990	241	6.0	3.5	114	108	94
D1-82	2150	6100	311	6.0	3.6	114	109	96
D1-83	2720	6610	393	6.0	3.9	114	109	99
D1-84	3460	11980	499	6.0	3.2	114	109	92
D1-85	4300	11540	620	6.0	3.7	114	109	97

This type can be supplied with height adjustment and/or damping.



Spring unit type D2, D3*

type	load capacity (N)		vertical spring constant (N/mm)	vertical natural frequency (Hz)		height (H in mm)		
	from	to		from	to	at delivery	from	loaded
D2-52	550	4270	79	6.0	2.2	158	155	108
D2-53	1110	7000	159	6.0	2.4	158	155	118
D2-55	2260	13210	326	6.0	2.5	158	155	121
D2-56	1580	10770	228	6.0	2.3	179	172	132
D3-57*	980	8330	140	6.0	2.0	258	255	203

This type can be supplied with height adjustment and/or damping.

*) D3 welded elements with baseplate 250 x 170 x 8 mm



Spring unit type W1, W1Q, W2, W2Q

type	load capacity (N)		vertical spring constant (N/mm)	vertical natural frequency (Hz)		height (H in mm)		
	from	to		from	to	at delivery	from	loaded
W1-441	1900	5770	276	6.0	3.5	69	65	51
W1-442	2230	5970	324	6.0	3.7	69	65	54
W1-443	2670	7220	388	6.0	3.7	69	65	53
W1-444	3250	7650	472	6.0	3.9	69	65	56
W1-445	3910	7900	568	6.0	4.2	69	65	58
W1-446	4770	9690	692	6.0	4.2	69	65	58
W1-447	5520	11360	800	6.0	4.2	69	65	58
W1-448	6700	13220	972	6.0	4.3	69	64	57
W1-548	8380	16530	1215	6.0	4.3	69	64	57
W2-431	1680	2670	60	3.0	2.4	108	105	89
W2-432	2050	3840	108	3.6	2.7	108	105	89
W2-433	3920	5660	140	3.0	2.5	108	105	93
W2-434	4800	9180	300	4.0	2.9	108	105	90
W2-435	7540	11950	580	4.4	3.5	108	105	97
W2-481	12530	19960	964	4.4	3.5	108	105	97
W2-482	9950	24390	1244	5.6	3.6	108	105	93
W2-483	12570	26410	1572	5.6	3.9	108	105	96
W2-484	15960	47910	1996	5.6	3.2	108	105	89
W2-485	19840	46130	2480	5.6	3.7	108	105	94

This type can be supplied with load-dependent height adjustment and/or damping.



Spring unit type GS1, GS2

type	load capacity (kN)		vertical spring constant (kN/mm)	vertical natural frequency (Hz)		height (H in mm)		
	from	to		from	to	at delivery	from	loaded
GS1-452	10	16	0.32	2.8	2.2	175	147	128
GS1-453	10	26	0.64	4.0	2.5	175	162	137
GS1-454	20	38	1.95	5.0	3.6	135	128	119
GS1-455	20	38	1.30	4.0	2.9	175	163	149
GS1-456	20	36	0.91	3.4	2.5	200	181	164
GS1-457	20	33	0.56	2.6	2.0	253	242	219
GS2-654	35	57	2.93	4.6	3.6	135	126	119
GS2-655	35	57	1.95	3.7	2.9	175	160	149
GS2-656	35	55	1.37	3.1	2.5	200	177	163
GS2-657	35	50	0.84	2.5	2.0	253	236	218

This type can be supplied with damping. Spring units are prestressable. Housings are made of welded steel.

D1

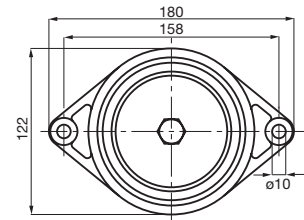
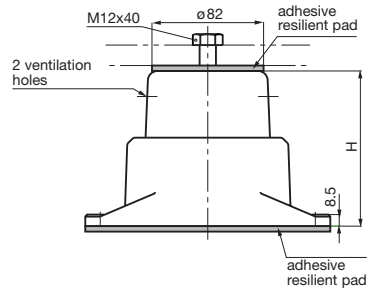

D2, D3*

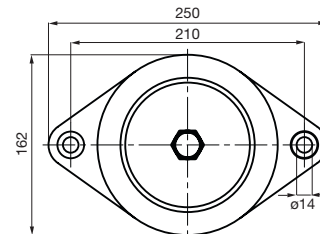
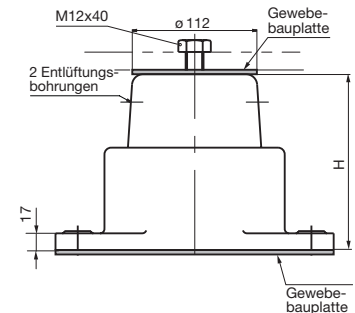

W1, W2

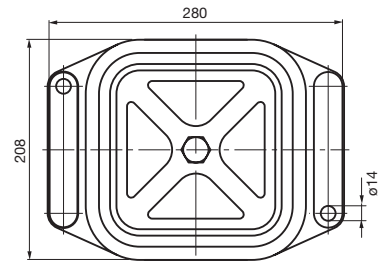
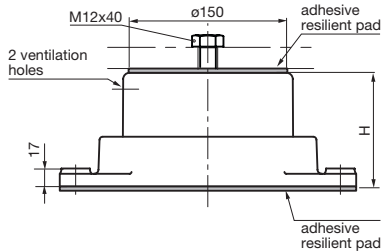

W1Q, W2Q

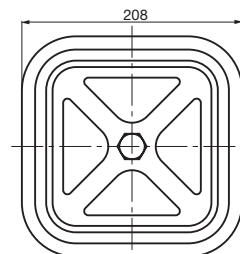
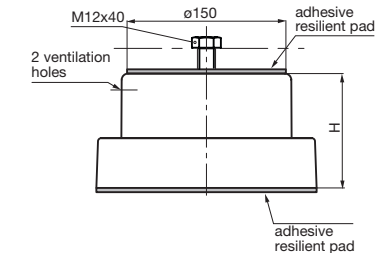

GS1

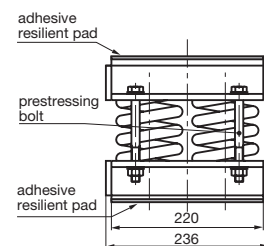
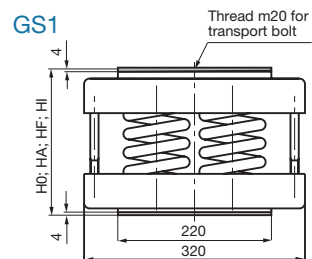

GS2

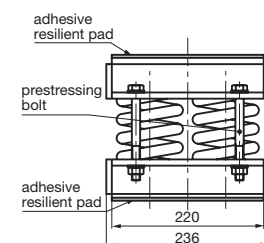
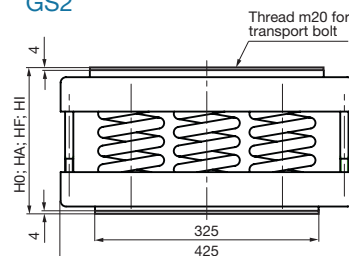



Spring Unit with and without Damping

We would appreciate to select suitable spring units for you. Please provide technical details of the machine or equipment to be isolated:

- ▶ Drawing or photo,
- ▶ Outer dimensions,
- ▶ Total weight,
- ▶ Centre of gravity
- ▶ Normal speed or number of strokes per minute.

GERB Schwingungsisolierungen GmbH & Co.KG

Roedernallee 174-176
13407 Berlin/ Germany
 Tel. +49-30-41 91-0
 Fax +49-30-41 91-199

Ruhrallee 311
45136 Essen/ Germany
 Tel. +49-201-266 04-0
 Fax +49-201-266 04-40

info@gerb.de
www.gerb.com

EN ISO 9001: 2000 Certified Company