

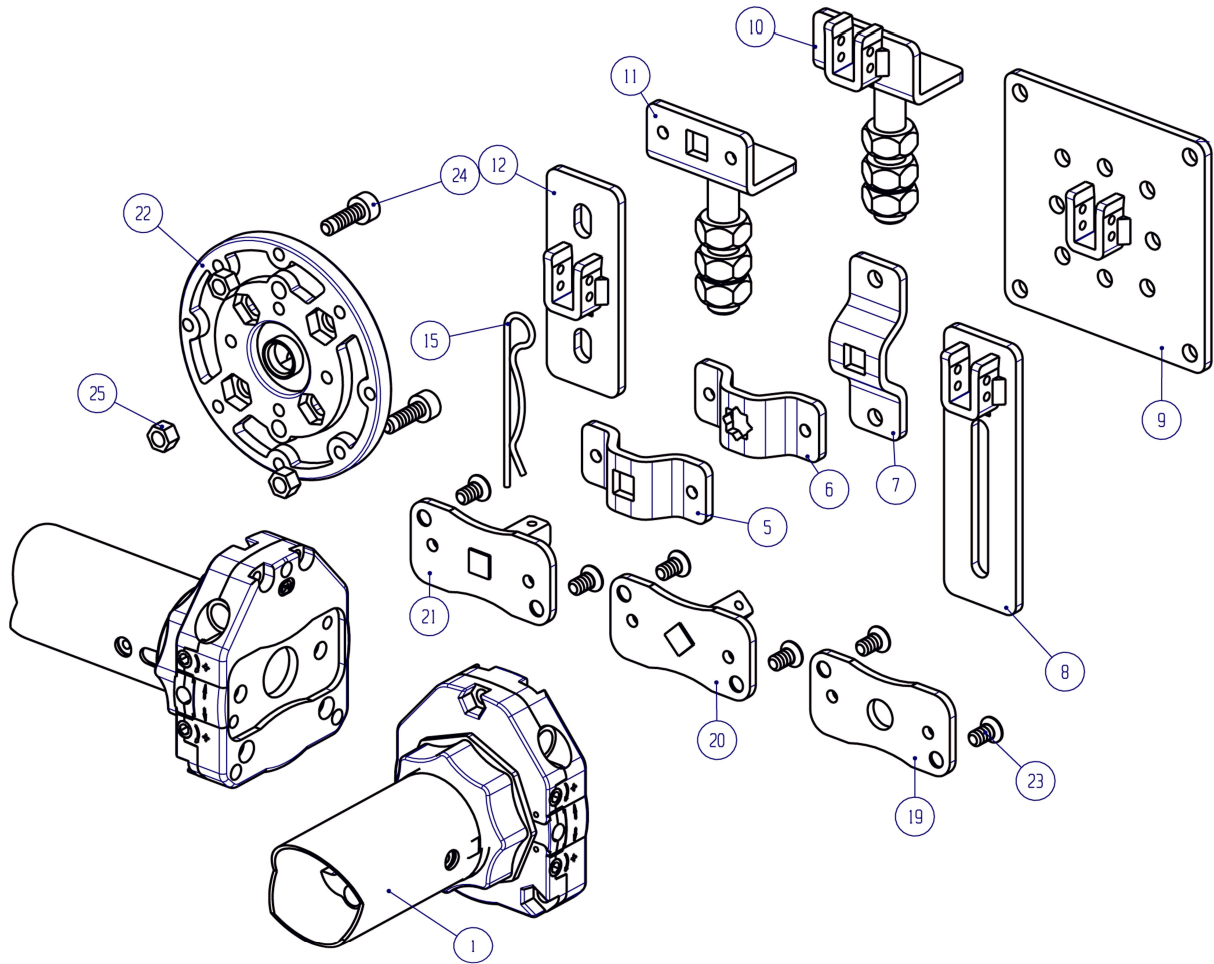

GEARMOTOR ASSEMBLY SYSTEMS - **SINCRO** SERIES



N.	Description	Code	N.	Description	Code
1	Motor - SINCRO-BRISOL series		21	Pin support - 90°, SINCRO	AC129
2			22	Thrust plate - aluminum, SINCRO	AC130
3			23	Screw - Phillips head, countersunk, flat, 6x10mm, zinc	
4			24	Screw - Phillips head, 6x25mm, zinc	
5	Support bracket - H62mm, 10x10mm square hole	AC017	25	Nut - M6	
6	Support bracket - H62mm, 45°/90° hole	AC127	26		
7	Support bracket - H74mm, 10x10mm square hole	AC018	27		
8	Support bracket - H116mm, 10mm dia. high mounting support	AC122	28		
9	Support bracket - H100mm square, 10mm dia. high mounting support	AC120	29		
10	Support bracket - M12 mounting support	AC034	30		
11	Pin support bracket - M12	AC032	31		
12	Support bracket - H90mm, 10mm dia. mounting support	AC124	32		
13			33		
14			34		
15	Security clip - 2mm dia.	VT152	35		
16			36		
17			37		
18			38		
19	Spacer - SINCRO	AC128	39		
20	Pin support - 45°, SINCRO	AC133	40		