



SJS10-TK

Capacity up to 13 tonnes

Supplied with safety block & stepped blocks

Maximum spread 60mm

- >> Single acting, spring assisted return
- >> Compact & lightweight design

The Hi-Force SJS10 hydraulic spreader offers the ideal solution for spreading, wedging and prising operations in a wide variety of industrial applications. The compact, low weight, spring assisted, piston retract design of the SJS10 offers the user a powerful 13 tonnes of spreading capacity. Manufactured from high strength steel, the low height jaw tips can easily fit within an 8mm gap and can provide a total spreading distance of 60mm in 5 operations, using the step blocks provided with the tool. Suitable for operation up to 700 Bar maximum working pressure, and supplied complete with a female half quick connect coupler for easy attachment to a Hi-Force manually operated or powered hydraulic pump.

Many applications require two tools, operated simultaneously, to achieve an even spread of a flange joint during gasket replacement. The SJS10-TK comprehensive kit offers the solution for this and comprises of two SJS10 spreaders, manually operated lightweight aluminium pump, controlled manifold, two pressure gauges, gauges blocks and hoses. All connections are fitted with quick release couplers and the set is supplied in a strong metal transport and storage box (pictured above).

The SJS10-M has all the features of the SJS10, but with the added benefit of an in built manually operated hand pump.

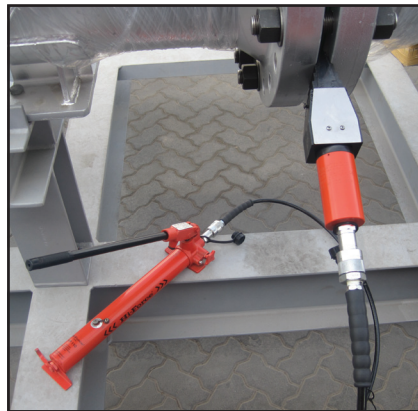
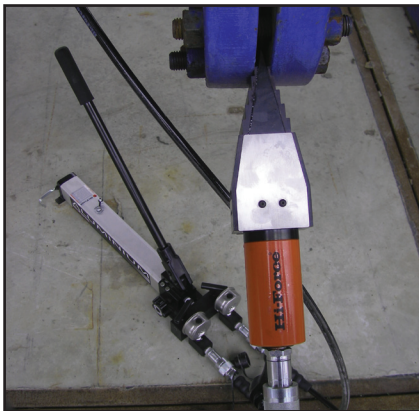

Single spreaders:

Model number	Capacity tonnes	Stroke mm	Min. height mm	Max. spread mm	Oil capacity cm <sup>3</sup>	Weight kg
<b>SJS10</b>	13	50	8	60	74	5.5
<b>SJS10-M</b>	13	50	8	60	74	7.5

Twin kit existing of:

Model number	Spreaders	Pump	Hoses	Manifold	Gauge	Gauge block	Metal box	Weight kg
<b>SJS10-TK</b>	SJS10 2 x	HP212 1 x	HC3C 2 x	HM2C 1 x	HG63G 2 x	HGA1-25 2 x	MSB1 1 x	34.5

## SJS - STEPPED JAW SPREADERS

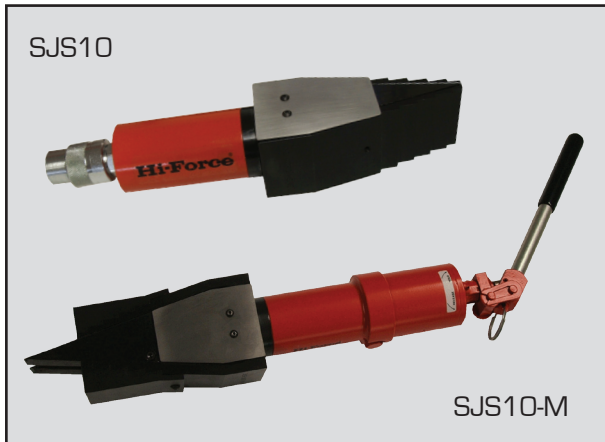

Capacity up to 13 tonnes

Supplied with safety block & stepped blocks

Maximum spread 60mm

- >> Single acting, spring assisted return
- >> Compact & lightweight design

All SJS10 & SJS10-M hydraulic spreaders are supplied complete with two stepped blocks (for increased spreading capacity) and one stepped safety block. The SJS10-TK comes complete with a double set of stepped and safety blocks.

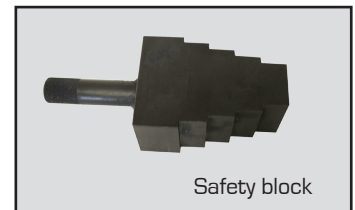

Safety block

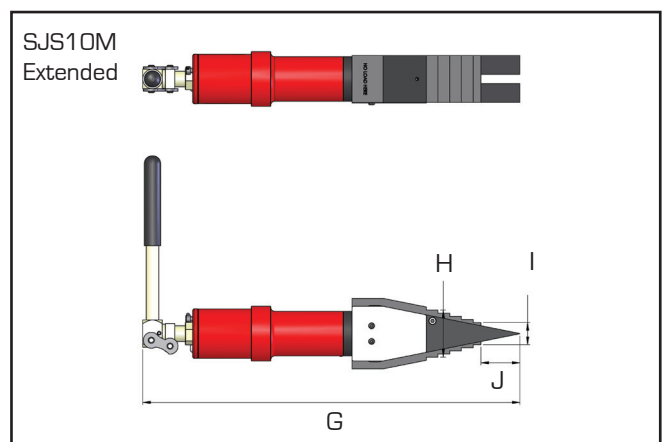
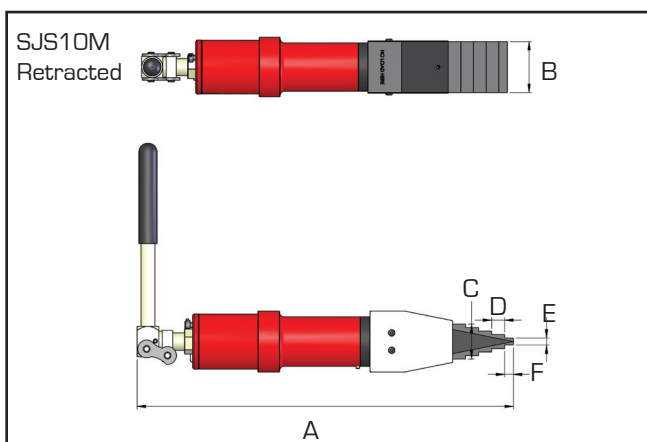
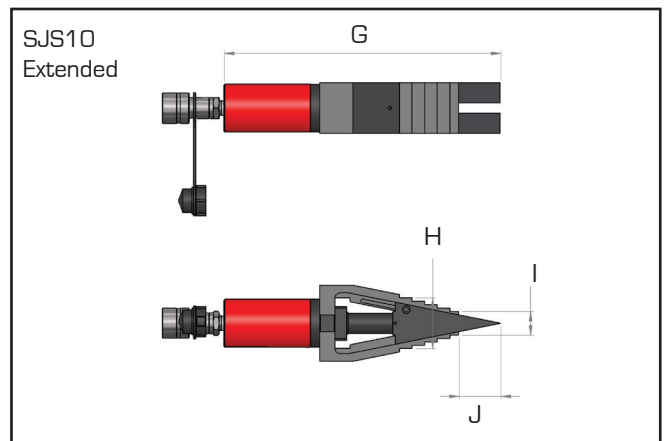
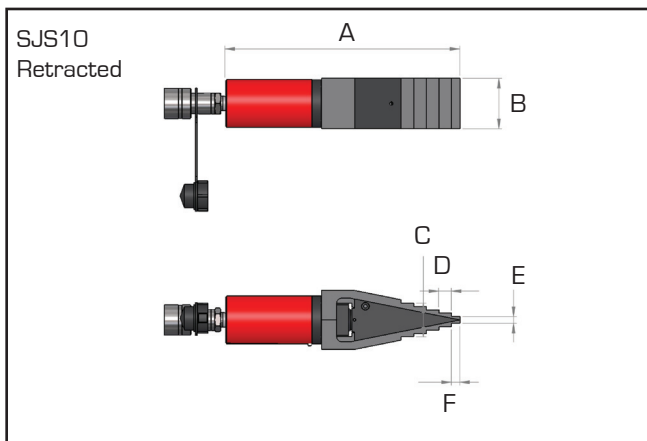

Model number	Capacity tonnes	Dimensions in mm									
		A	B	C	D	E	F	G	H	I	J
<b>SJS10</b>	13	279	60	40	15	8	10	328	60	28	49
<b>SJS10-M</b>	13	433	60	40	15	8	10	483	60	28	49