



# Switch Amplifier

## HiC2841

- 1-channel isolated barrier
- 24 V DC supply (bus powered)
- Dry contact or NAMUR input
- Usable as signal splitter (1 input and 2 outputs)
- 2 passive transistor outputs
- Fault transistor output
- Line fault detection (LFD)
- Reversible mode of operation
- SIL 2 (SC 3) acc. to IEC/EN 61508



### Function

This isolated barrier is used for intrinsic safety applications.

The device transfers digital signals (NAMUR sensors/mechanical contacts) from the explosion-hazardous area to the non-explosion-hazardous area.

The input controls two passive transistors for the non-explosion-hazardous area load.

Via switches the mode of operation can be reversed and the line fault detection can be switched off.

Via switch the function of the second output can be defined as a signal output or a fault indication output.

During a fault state, the transistors revert to their de-energized state and LEDs indicate the fault according to NAMUR NE 44. A separate fault bus is available. This fault bus can be monitored if the termination board supports a module fault detection.

This device mounts on a HiC termination board.

### Connection

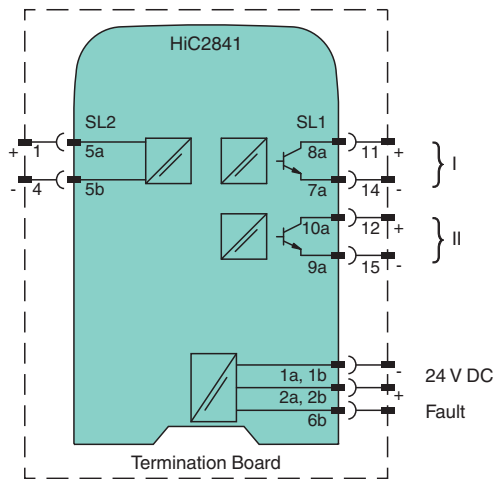
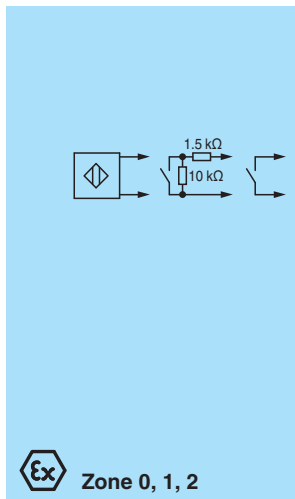

Release date: 2022-09-15 Date of issue: 2022-09-15 Filename: 214233\_eng.pdf

Refer to "General Notes Relating to Pepperl+Fuchs Product Information".

Pepperl+Fuchs Group  
www.pepperl-fuchs.com

USA: +1 330 486 0002  
pa-info@us.pepperl-fuchs.com

Germany: +49 621 776 2222  
pa-info@de.pepperl-fuchs.com

Singapore: +65 6779 9091  
pa-info@sg.pepperl-fuchs.com

**PEPPERL+FUCHS**

Configuration

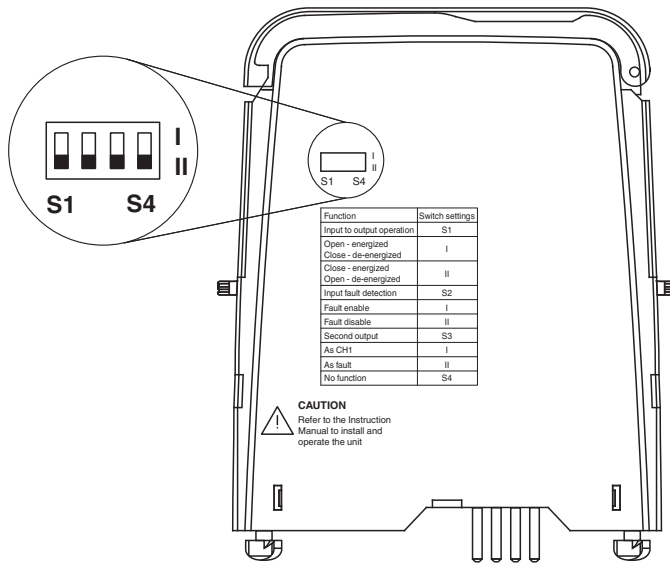

Technical Data

General specifications		
Signal type		Digital Input
Functional safety related parameters		
Safety Integrity Level (SIL)		SIL 2
Systematic capability (SC)		SC 3
Supply		
Connection		SL1: 1a(-), 1b(-); 2a(+), 2b(+)
Rated voltage	$U_r$	19 ... 30 V DC bus powered via Termination Board
Ripple		$\leq 10 \%$
Rated current	$I_r$	$\leq 25 \text{ mA}$
Power dissipation		$\leq 500 \text{ mW}$
Power consumption		$\leq 600 \text{ mW}$
Input		
Connection side		field side
Connection		SL2: 5a(+), 5b(-)
Rated values		acc. to EN 60947-5-6 (NAMUR), see manual for electrical data
Open circuit voltage/short-circuit current		approx. 10 V DC / approx. 8 mA
Switching point/switching hysteresis		1.2 ... 2.1 mA / approx. 0.2 mA
Line fault detection		breakage $I \leq 0.1 \text{ mA}$ , short-circuit $I \geq 6.5 \text{ mA}$
Pulse/Pause ratio		min. 100 $\mu\text{s}$ / min. 100 $\mu\text{s}$
Output		
Connection side		control side
Connection		SL1: 8a(+), 7a(-); 10a(+), 9a(-)
Rated voltage	$U_r$	30 V DC
Rated current	$I_r$	50 mA
Response time		$\leq 200 \mu\text{s}$
Signal level		1-signal: (external voltage) - 1 V max. for 50 mA ( $T_{amb} = 25 \text{ }^\circ\text{C}$ (77 $^\circ\text{F}$ )) 0-signal: blocked output (off-state current $\leq 10 \mu\text{A}$ )
Output I		signal ; Transistor

Release date: 2022-09-15 Date of issue: 2022-09-15 Filename: 214233\_eng.pdf

Refer to "General Notes Relating to Pepperl+Fuchs Product Information".

## Technical Data

Output II		signal or fault message ; Transistor
<b>Fault indication output</b>		
Connection		SL1: 6b
Output type		open collector transistor (internal fault bus)
<b>Transfer characteristics</b>		
Switching frequency		≤ 5 kHz
<b>Galvanic isolation</b>		
Output/power supply		basic insulation acc. to EN 50178, rated insulation voltage of 50 V AC
Output/Output		basic insulation acc. to EN 50178, rated insulation voltage of 50 V AC
<b>Indicators/settings</b>		
Display elements		LEDs
Control elements		DIP switch
Configuration		via DIP switches
Labeling		space for labeling at the front
<b>Directive conformity</b>		
Electromagnetic compatibility		
Directive 2014/30/EU		EN 61326-1:2013 (industrial locations)
<b>Conformity</b>		
Galvanic isolation		EN 50178:1997
Electromagnetic compatibility		NE 21:2012 For further information see system description.
Degree of protection		IEC 60529
Protection against electrical shock		IEC 61140
<b>Ambient conditions</b>		
Ambient temperature		-40 ... 70 °C (-40 ... 158 °F)
Relative humidity		≤ 90 % , non-condensing
<b>Mechanical specifications</b>		
Degree of protection		IP20
Mass		approx. 90 g
Dimensions		12.5 x 106 x 128 mm (0.5 x 4.2 x 5.1 inch) (W x H x D)
Mounting		on termination board
Coding		pin 1 and 2 trimmed For further information see system description.
<b>Data for application in connection with hazardous areas</b>		
EU-type examination certificate		BVS 09 ATEX E 157
Marking		⊕ II (1)G [Ex ia Ga] IIC ⊕ II (1)D [Ex ia Da] IIC ⊕ I (M1) [Ex ia Ma] I
Input		Ex ia, Ex iaD
Voltage	U <sub>o</sub>	10.5 V
Current	I <sub>o</sub>	17.1 mA
Power	P <sub>o</sub>	45 mW (linear characteristic)
Supply		
Maximum safe voltage	U <sub>m</sub>	253 V AC (Attention! U <sub>m</sub> is no rated voltage.)
Output		
Maximum safe voltage	U <sub>m</sub>	253 V AC (Attention! The rated voltage can be lower.)
Galvanic isolation		
Input/Output		safe electrical isolation acc. to IEC/EN 60079-11, voltage peak value 375 V
Input/power supply		safe electrical isolation acc. to IEC/EN 60079-11, voltage peak value 375 V
Directive conformity		
Directive 2014/34/EU		EN IEC 60079-0:2018+AC:2020 , EN 60079-11:2012 , EN 50303:2000
<b>International approvals</b>		
UL approval		E106378
Control drawing		116-0331

Release date: 2022-09-15 Date of issue: 2022-09-15 Filename: 214233\_eng.pdf

**Technical Data**

IECEX approval	
IECEX certificate	IECEX BVS 09.0060
IECEX marking	[Ex ia Ga] IIC , [Ex ia Da] IIIC , [Ex ia Ma] I
<b>General information</b>	
Supplementary information	Observe the certificates, declarations of conformity, instruction manuals, and manuals where applicable. For information see <a href="http://www.pepperl-fuchs.com">www.pepperl-fuchs.com</a> .

**Assembly**

**Front view**

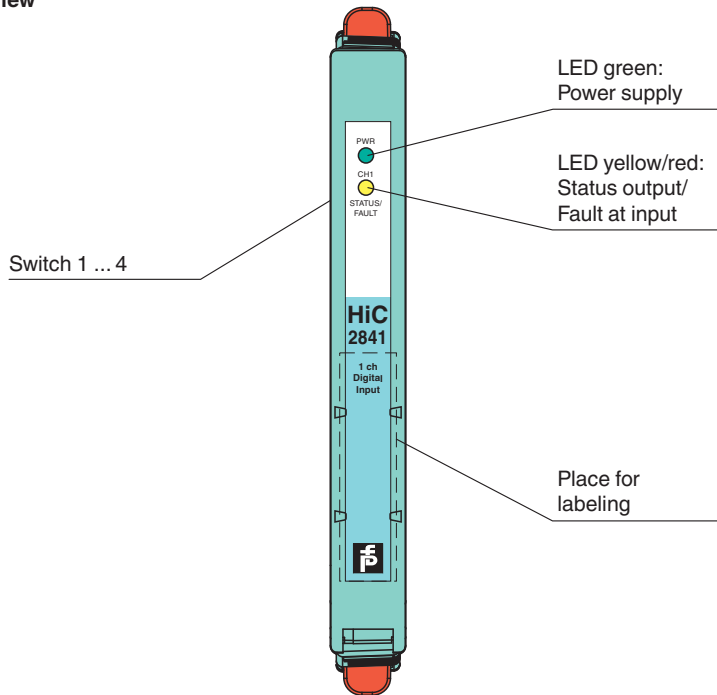

Release date: 2022-09-15 Date of issue: 2022-09-15 Filename: 214233\_eng.pdf

Refer to "General Notes Relating to Pepperl+Fuchs Product Information".

Pepperl+Fuchs Group  
www.pepperl-fuchs.com

USA: +1 330 486 0002  
pa-info@us.pepperl-fuchs.com

Germany: +49 621 776 2222  
pa-info@de.pepperl-fuchs.com

Singapore: +65 6779 9091  
pa-info@sg.pepperl-fuchs.com

## Configuration

Configure the device in the following way:

- Push the red Quick Lok Bars on each side of the device in the upper position.
- Remove the device from Termination Board.
- Set the DIP switches according to the figure.



*The pins for this device are trimmed to polarize it according to its safety parameter. Do not change!  
For further information see system description.*