



Logix™ 3800 Digital Positioner FCD LGENIM0112-07 04/21

USER INSTRUCTIONS

Logix™ 3800
Digital Positioner

FCD LGENIM0112-07 04/21

Installation
Operation
Maintenance
Safety



Experience In Motion

CONTENTS

1	QUICK START GUIDE	3
2	SAFETY INFORMATION	9
3	PRE-INSTALLATION	11
4	INSTALLATION – MOUNTING	16
5	INSTALLATION - TUBING.....	22
6	INSTALLATION – ELECTRICAL CONNECTIONS (HART).....	24
7	INSTALLATION – ELECTRICAL CONNECTIONS (FF)	29
8	OPERATION - HOW IT WORKS.....	31
9	OPERATION – DIP SWITCH CONFIGURATION	33
10	OPERATION – CALIBRATION AND CONTROL	35
11	OPERATION – USER INTERFACE	37
12	OPERATION – DIAGNOSTIC LEVELS	41
13	MAINTENANCE – TROUBLESHOOTING.....	42
14	MAINTENANCE - REPAIR	45
15	MAINTENANCE - HELP FROM FLOWSERVE	48
16	POSITIONER SPECIFICATIONS.....	49
17	HAZARDOUS LOCATION SPECIFICATIONS	53
18	SIL 3 REQUIREMENTS FOR SAFETY INTEGRITY	64
	APPENDIX A – LCD MENU TREE OVERVIEW.....	66
	APPENDIX B – LCD MENU TREE DESCRIPTIONS	67
	APPENDIX C – PROGRAMMED FLOW CHARACTERIZATION OPTIONS.....	74
	APPENDIX D – 4-BLINK STATUS CODES	76
	APPENDIX E – STATUS CODE DESCRIPTIONS	79
	APPENDIX F – HOT KEYS	94
	APPENDIX G - HOW TO ORDER.....	96

1 QUICK START GUIDE

1.1 Logix 3800 Positioner Features



Figure 1: Logix 3800 External Positioner Features (EX and SS)

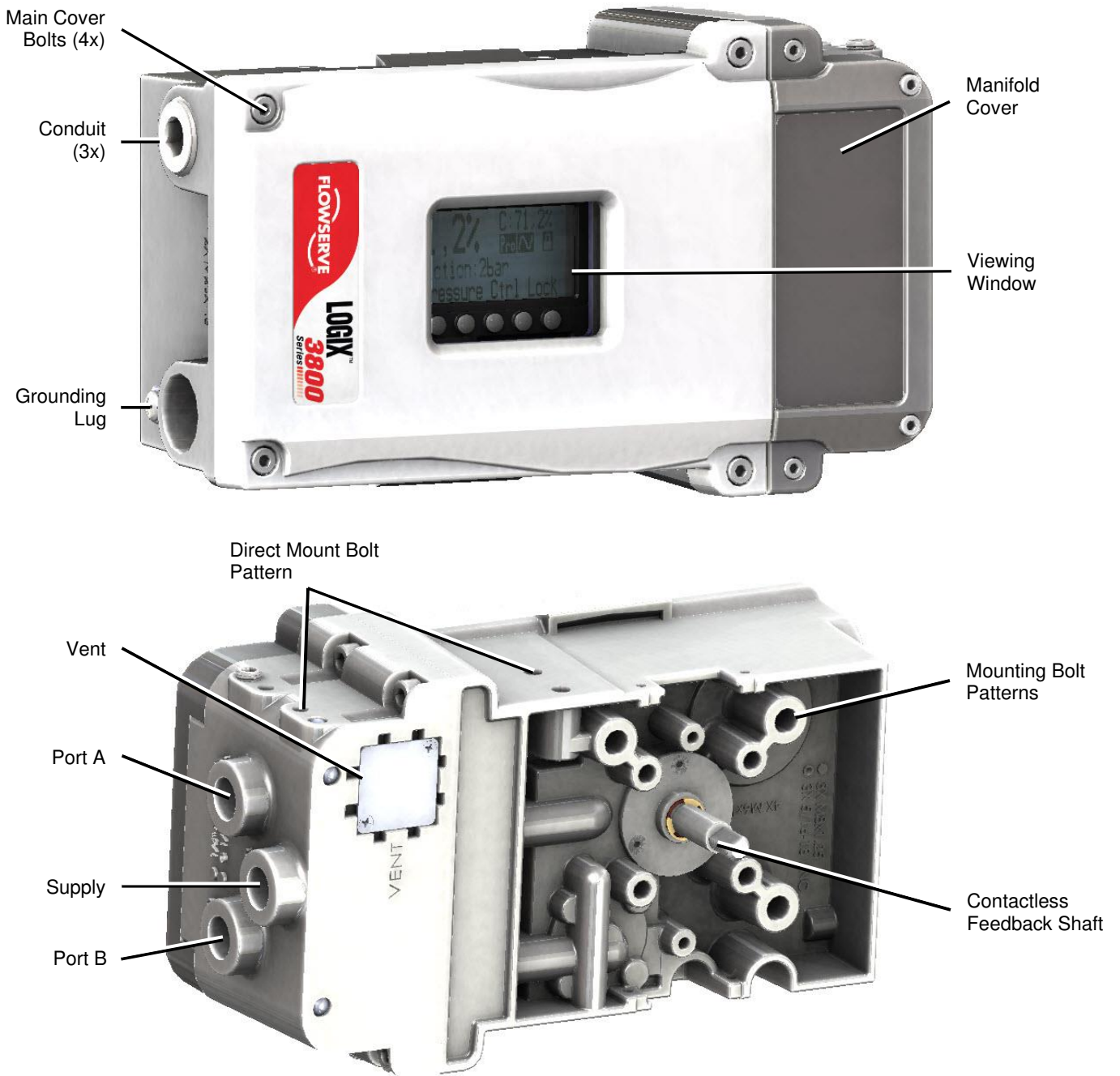

Figure 2: Logix 3800 External Positioner Features (IS)

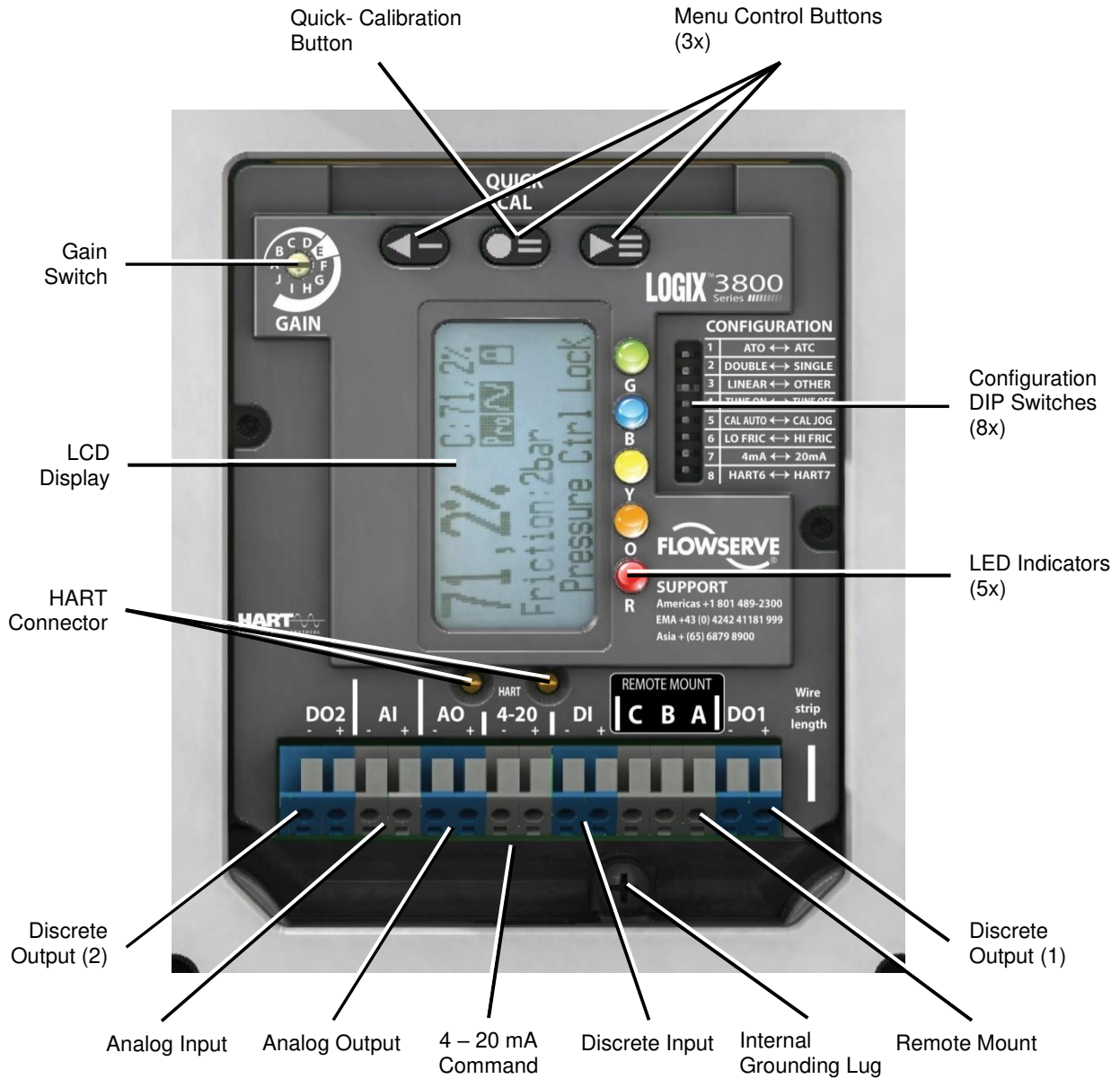

Figure 3: Logix 3820 (HART) Internal Positioner Features

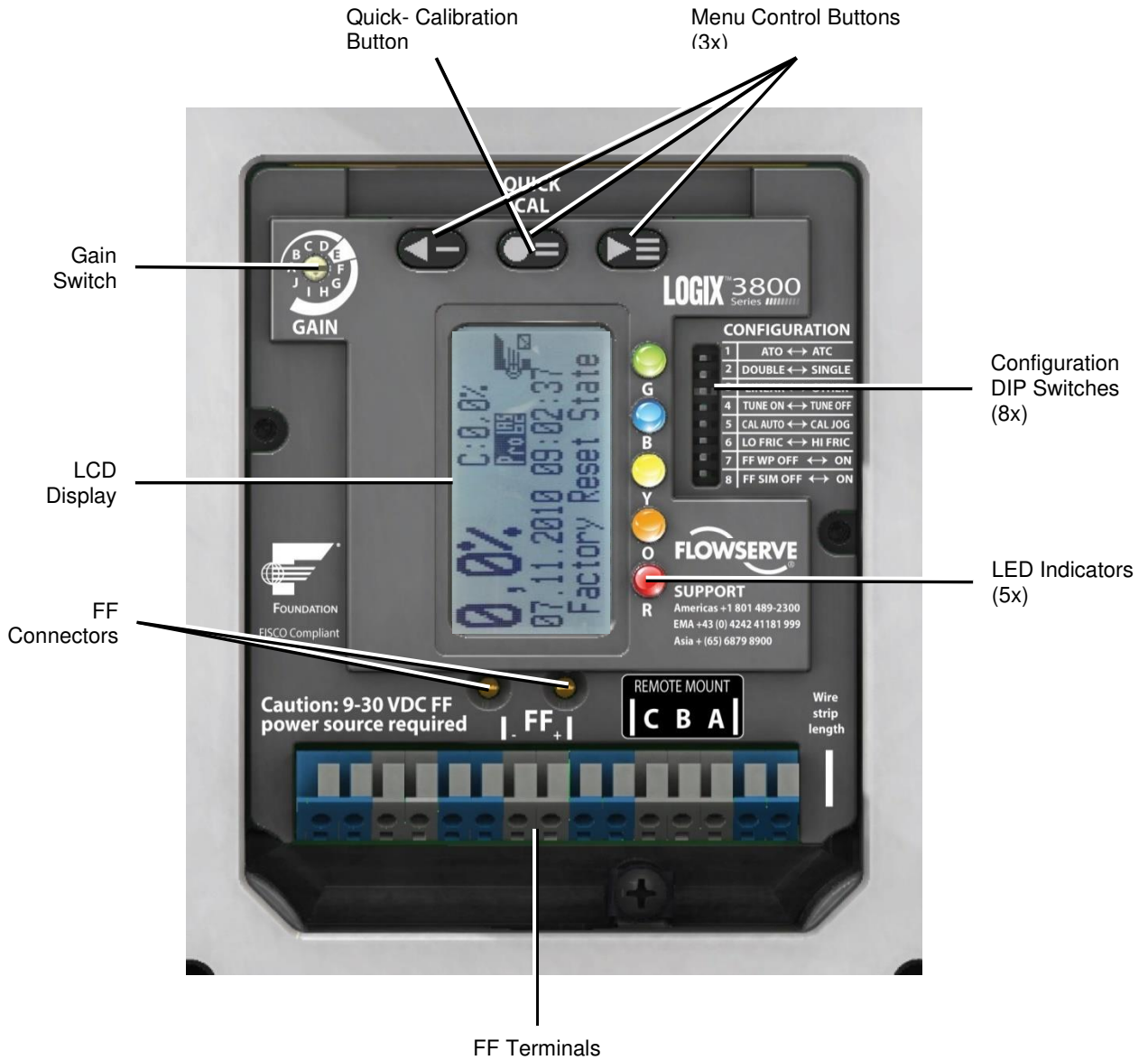

Figure 4: Logix 3840 (Foundation Fieldbus) Internal Positioner Features

1.2 Safety

⚠ CAUTION: Before installation, read all safety related information in section 2 Safety Information.

1.3 Installation

MOUNTING

Securely mount the positioner to the actuator using the bolt pattern on the back of the positioner or use the direct mount block option. See section 4, Installation – Mounting, for more detail.

FEEDBACK

Connect feedback linkage. Align the follower arm to move freely within the expected range of valve travel. Over-rotating the feedback shaft will not damage the unit.

PNEUMATIC CONNECTIONS

Connect pneumatic ports A and B to the actuator. Port A should typically be connected to the side of the actuator opposing the actuator spring. With air supplied, but no electrical power to the system, port A will vent, and leave port B pressurized. For single acting actuators, connect to port A and plug port B. See section 5, Installation - Tubing, for more detail.

⚠ CAUTION: Connecting the supply air may cause the valve to move. Before connecting supply air, ensure the valve is isolated.

Connect port S to a clean, filtered air supply. See section 16, Positioner Specifications, for air cleanliness specifications.

ELECTRICAL CONNECTIONS (HART)

⚠ CAUTION: Connecting the 4-20 mA signal may cause the valve to move. Before connecting electrical signal, ensure the valve is isolated.

Connect a 4-20 mA signal to the terminals labeled “4-20” or the tabs labeled “HART.” The tabs should only be used for temporary testing and are not meant as a permanent connection. A signal above 3.8 mA will activate the positioner. LEDs on the positioner will light up indicating power is connected. SIL

ELECTRICAL CONNECTIONS (FF)

⚠ CAUTION: After connecting the FF signal, the valve may move. Before connecting electrical signal, ensure the valve is isolated.

Connect the FF signal to the terminals labeled “FF” or the corresponding tabs. LEDs on the positioner will light up indicating power is connected.

1.4 Configuration

Set the configuration dip switches. See section 9, Operation – Dip Switch Configuration, for more detail.

AIR ACTION DIP SWITCH (ATO ◀▶ ATC)

For increasing pressure in port A to open the valve (air to open) select “ATO.” For increasing pressure in port A to close the valve (air to close) select “ATC.”

ACTUATOR SWITCH (DOUBLE ◀▶ SINGLE)

For double-acting actuators select “DOUBLE.” For single-acting actuators, select “SINGLE.”

CHARACTERIZATION SWITCH (LINEAR ◀▶ OTHER)

For a linear relationship between the command signal and the position of the valve, select “LINEAR.” To customize the characterization curve, select “OTHER.” Other curves can be chosen using the LCD menu, a handheld device, or DTM. See Appendix C – Programmed Flow Characterization Options for a table and graph describing the “OTHER” options.

AUTO TUNE SWITCH (TUNE ON ◀▶ TUNE OFF)

For the QUICK-CAL calibration to automatically select custom tuning parameters, select TUNE ON (preferred). For default tuning parameters, select TUNE OFF.

JOG CALIBRATION SWITCH (CAL AUTO ◀▶ CAL JOG)

For valves with a mechanical stop at the fully opened position (most valves), select CAL AUTO. For valves with no mechanical stop, select CAL JOG. This allows the user to set the upper limit of travel by jogging the position manually.

VALVE STABILITY SWITCH (LO FRIC ◀▶ HI FRIC)

For valves with normal friction, select LO FRIC. For valves with very high friction, select HI FRIC.

SIGNAL AT CLOSED SWITCH (HART) (4mA ◀▶ 20mA)

For a 4mA signal to move the valve to a closed position, select 4mA. For a 20mA signal to move the valve to closed, select 20mA.

HART SWITCH (HART) (HART 6 ◀▶ HART 7)

For HART 6 protocol, select HART6. For HART 7 protocol, select HART7.

FF WRITE PROTECT SWITCH (FOUNDATION FIELDBUS) (FF WP OFF ◀▶ ON)

To write protect variables and inputs, select ON. To leave variables writeable, select OFF. For more information, see the Logix 3800 FF Reference Guide, LGENIM3840.

FF SIMULATION SWITCH (FOUNDATION FIELDBUS) (FF SIM OFF ◀▶ ON)

For normal operation, select OFF. To place in simulation mode, select ON. For more information, see the Logix 3800 FF Reference Guide, LGENIM3840.

1.5 Calibration

⚠ CAUTION: *During the QUICK-CAL operation the valve may stroke unexpectedly. Notify proper personnel that the valve will stroke, and make sure the valve is properly isolated.*

QUICK-CAL

The QUICK-CAL  button is used to initiate an automatic stroke calibration. This stroke calibration determines the closed (0%) and open (100%) positions of the valve and gathers information about the response of the valve to determine the control gains. The gains are automatically set. After a QUICK-CAL calibration, the positioner is ready to control.

To perform a QUICK-CAL, press and hold the QUICK-CAL  button for approximately 3 seconds, then release.

During the calibration, the LED lights will flash Yellow-Red-Yellow-Green indicating the calibration is in progress. After the calibration is complete, the LED lights should flash Green-Green-Green-Green indicating a successful calibration.

🔄 NOTE: *This first time the QUICK-CAL is performed, the positioner will also complete a Full Calibration. This will extend the time required for the calibration. This happens with Standard and Pro diagnostic levels.*

GAIN SWITCH

After the calibration, (and at any time during operation), fine tune the gains by adjusting the Selectable GAIN Switch. Selecting “A” through “D” will provide a more stable or slower response. Selecting “F” through “J” will provide a more active or quicker response. The “E” position is the default and is typically more stable.

--- END OF QUICK START GUIDE ---

2 SAFETY INFORMATION





2.1 Using This Document

Product users and maintenance personnel should thoroughly review this manual before installing, operating, or performing any maintenance on the positioner.

The following instructions are designed to assist in unpacking, installing and performing maintenance as required on Logix™ 3800 positioners. Logix 3800 is the term used for all the positioners herein; however, specific numbers indicate features specific to model (i.e., Logix 3820 indicates that the positioner has HART® protocol and 3840 indicates Foundation Fieldbus).

Separate Flow Control Products User Instructions cover the valve, actuator, or other portions of the system and other accessories. Refer to the appropriate instructions when this information is needed. The design of FLOWSERVE valves, actuators, and accessories are for specific applications considering medium, pressure, and temperature in most cases. For this reason, do not use them in other applications without first contacting the manufacturer.

2.2 Terms Concerning Safety

The safety terms  **NOTE**,  **CAUTION**, and  **DANGER** are used in these instructions to highlight particular hazards and to provide additional information on aspects that may not be readily apparent.  **DANGER** and  **CAUTION** notes must be strictly followed to avoid possible injury to personnel or damage to equipment or property.

 **NOTE:** *Indicates and provides additional technical information, which may not be obvious.*

 **CAUTION:** *Proper precautions must be observed to avoid minor personal injury and property damage.*

 **DANGER:** *Indicates that death, severe personal injury and/or substantial property damage can occur if proper precautions are not taken.*

Compliance with notes about installation, operation, maintenance and technical documentation (e.g. in the operating instruction, product documentation or on the positioner) is essential to avoid faults, which in themselves might directly or indirectly cause severe personal injury or property damage.

2.3 Protective Clothing

FLOWSERVE positioners use high-pressure gas to operate. Use eye protection when working around pressurized equipment. Follow proper procedures for working with natural gas.

 **DANGER:** *Standard industry safety practices must be adhered to when working on this or any process control product. Specifically, use personal protective equipment as warranted.*

2.4 Qualified Personnel

Qualified personnel are people who, on account of their training, experience, instruction and their knowledge of relevant standards, specifications, accident prevention regulations and operating conditions, have been authorized by those responsible for the safety of the plant to perform the necessary work and who can recognize and avoid possible dangers.

In unpacking, installing and performing maintenance as required on FLOWSERVE products, product users and maintenance personnel should thoroughly review this manual before installing, operating, or performing any maintenance.

2.5 Valve and Actuator Variations

These instructions cannot claim to cover all details of all possible product variations, nor can they provide information for every possible example of installation, operation scenario, or maintenance requirement. Qualified personnel should follow the instructions provided and only use the product for its defined purpose. If clarification is needed or there are any uncertainties in this respect, particularly in the event of missing product-related information, immediately contact the appropriate Flowserve sales office. Contact information is listed at the back of this manual.

2.6 Spare Parts

Use only FLOWSERVE original components. FLOWSERVE cannot accept responsibility for any damages that occur from using components or fastening materials from other manufacturers. If FLOWSERVE products (especially sealing materials) have been in storage for longer periods, check them for corrosion or deterioration before using these products. See Appendix G - How To Order for more information.

2.7 Service / Repair

 **CAUTION:** *Proper precautions must be strictly observed to avoid possible personal injury and property damage.*

Modifying this product, substituting non-factory parts, or using maintenance procedures other than outlined in this instruction could drastically affect performance and be hazardous to personnel and equipment, and may void existing warranties.

There are moving parts between the actuator and the valve. To avoid injury FLOWSERVE provides pinch-point-protection in the form of cover plates, especially with side-mounted positioners. Special attention is required when removing these plates for inspection, service or repair. Refit the cover plates after completing work.

Logix 3800 positioner repair is limited to the replacement of sub-assemblies and circuit boards with FLOWSERVE-manufactured replacements as outlined in this manual.

DANGER: *Substitution with non-factory positioner components may impair intrinsic safety.*

CAUTION: *Before returning products to FLOWSERVE for repair or service, provide a certificate to FLOWSERVE which confirms that the product has been decontaminated and is clean; FLOWSERVE will not accept deliveries if a certificate is not provided (a form is available from FLOWSERVE).*

Apart from the operating instructions and the necessary accident prevention directives valid in the country of use, follow all recognized regulations for safety and good engineering practices.

2.8 Natural Gas Service

If a natural gas model positioner is ordered, then the use of natural gas as an actuation medium with a FLOWSERVE Logix 3800 positioner is acceptable.

CAUTION: *The natural gas used must be sweet natural gas. Use of sour natural gas may cause positioner to fail prematurely.*

DANGER: *The Logix 3800 is vented directly to atmosphere. The substitution of sweet natural gas as the air supply requires piping to route the exhausted natural gas to a safe environment. Refer to section 5.4, Venting, for venting details.*

3 PRE-INSTALLATION

3.1 Storage

It is mandatory to store FLOWSERVE control valves and instruments in a clean, dry environment. Prevent flooding of the equipment, including rainwater, that can pool in packaging materials. Prevent dirt or sand accumulation in the pneumatic and valve ports. Plastic caps are fitted to protect positioner ports from ingress of foreign materials. These caps should be removed before fitting with conduit or air supply lines.

If FLOWSERVE products have been in storage for longer periods, check them for corrosion or deterioration before using these products. The end user must provide fire protection for FLOWSERVE products.

NOTE: *The positioner is not IP66/NEMA 4X certified until installed and temporary plugs have been fitted with tubing, conduit or permanent plugs.*

3.2 Unpacking

While unpacking the valve and Logix 3800 positioner, check the packing list against the materials received. Each shipping container includes a list describing the system and accessories included.

In the event of shipping damage, contact the shipper immediately. Should any problems arise, please contact a FLOWSERVE Flow Control Division representative. Phone numbers are at the back of the manual.

Remove the plastic plugs (blue color) from the conduit and pneumatic ports before installing. Replace with plugs that will seal the opening using either 1/4" NPT, 1/2" NPT or M20 threaded plug, depending on the housing, which is clearly marked.

CAUTION: *The plastic plugs in the conduit and pneumatic ports are intended only to protect the threads during shipment. Failure to replace these with a sealing plug may result in liquid and debris ingress and damage to the positioner.*

DANGER: *When lifting a valve/actuator assembly with lifting straps, be aware that the center of gravity may be above the lifting point. Therefore, support must be given to prevent the valve/actuator from rotating and falling. Failure to do so can cause serious injury to personnel or damage to nearby equipment.*

3.3 Pre-installation Inspection

When installing a positioner, check the feedback shaft for damage and that the plugs and cover are in place. If there is contamination in the positioner, clean the positioner components gently with a soft damp cloth. One may remove some parts for better access. Do not get water on the electronics assembly.

3.4 Label Verification

Verify that the labels match the intended application. See section 17, Hazardous Location Specifications, for more details.

NOTE: The installer should mark the checkbox on the label that is appropriate for the intended use of the Logix 3800.

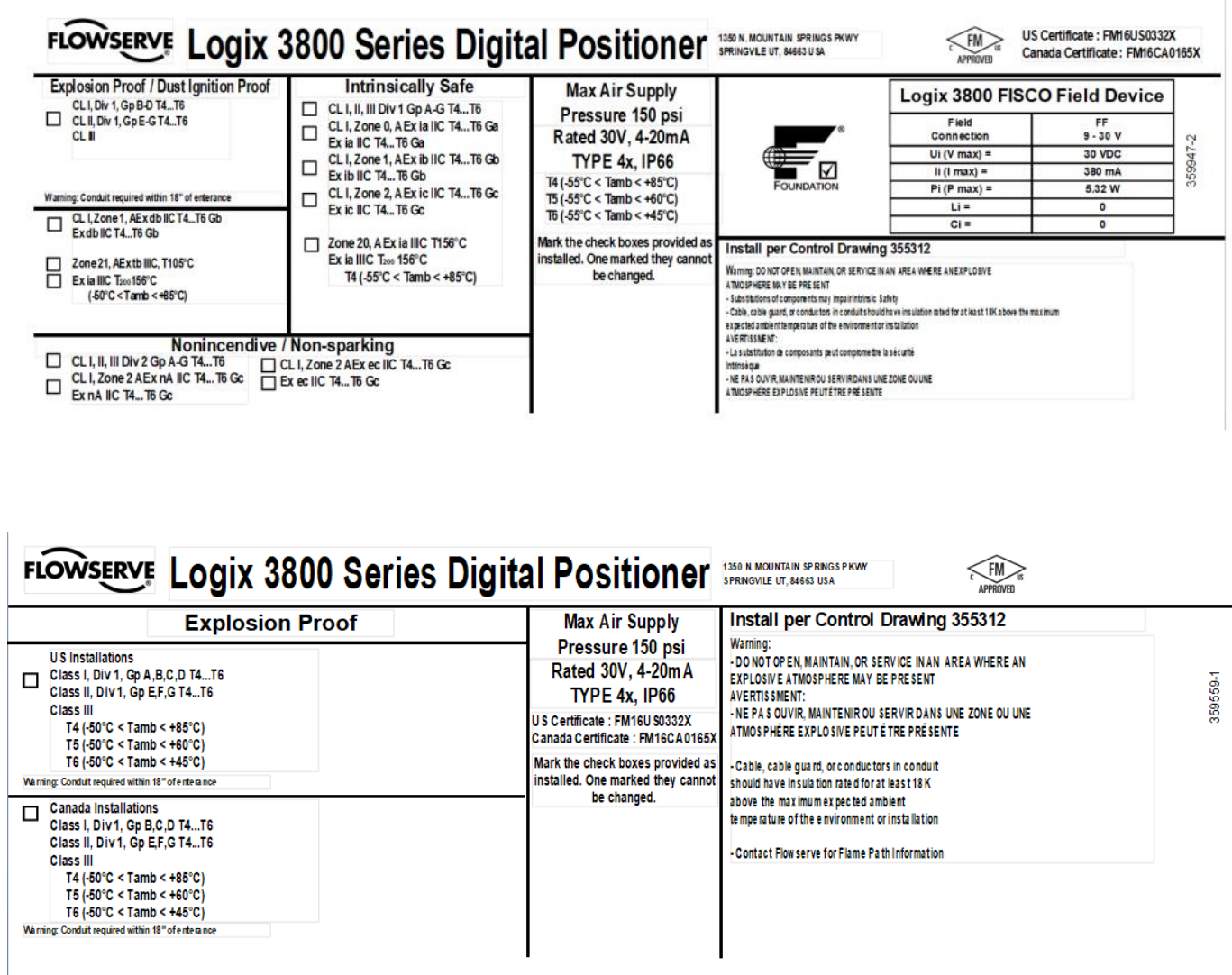

Figure 5: Certification Labels

FLOWERVE Logix 3800 Series Digital Positioner

1350 N. MOUNTAIN SPRINGS PKWY
SPRINGVILLE UT, 84603 USA



US Certificate: FM6US0332X
Canada Certificate: FM16CAD165X

<p>Explosion Proof / Dust Ignition Proof</p> <p>CL I, Div 1, Gp B D T4...T6 CL II, Div 1, Gp E G T4...T6 CL III</p> <p>Warning: Conduit required within 18" of entrance</p> <p>CL I, Zone 1, AEx db IIC T4...T6 Gb Ex db IIC T4...T6 Gb</p> <p>Zone 2I, AEx tb IIIC, T105°C Ex ia IIIC T₂₀₀156°C (-50°C < Tamb < +85°C)</p>	<p>Intrinsically Safe</p> <p>CL I, II, III Div 1 Gp A-G T4...T6 CL I, Zone 0, AEx ia IIC T4...T6 Ga Ex ia IIC T4...T6 Ga</p> <p>CL I, Zone 1, AEx ib IIC T4...T6 Gb Ex ib IIC T4...T6 Gb</p> <p>CL I, Zone 2, AEx ic IIC T4...T6 Gc Ex ic IIC T4...T6 Gc</p> <p>Zone 20, AEx ia IIIC T156°C Ex ia IIIC T₂₀₀156°C T4 (-55°C < Tamb < +85°C)</p>	<p>Max Air Supply</p> <p>Pressure 150 psi Rated 30V, 4-20mA TYPE 4x, IP66</p> <p>T4 (-55°C < Tamb < +85°C) T5 (-55°C < Tamb < +60°C) T6 (-55°C < Tamb < +45°C)</p> <p>Mark the check boxes provided as installed. One marked they cannot be changed.</p>	<p>Logix 3800 Entity Parameters</p> <table border="1"> <thead> <tr> <th>Field Connection</th> <th>4 - 20</th> <th>Optional D01 & D02</th> <th>Optional AI</th> <th>Optional AO</th> <th>Optional DI</th> </tr> </thead> <tbody> <tr> <td>Ui =</td> <td>30 VDC</td> <td>30 VDC</td> <td>30 VDC</td> <td>30 VDC</td> <td>30 VDC</td> </tr> <tr> <td>Ii =</td> <td>380 mA</td> <td>500 mA</td> <td>250 mA</td> <td>250 mA</td> <td>380 mA</td> </tr> <tr> <td>Pi =</td> <td>5.32 W</td> <td>2.5 W</td> <td>3.8 W</td> <td>2.0 W</td> <td>5.32 W</td> </tr> <tr> <td>Li =</td> <td>0</td> <td>0</td> <td>0</td> <td>0</td> <td>0</td> </tr> <tr> <td>CI =</td> <td>0</td> <td>23 nF</td> <td>0</td> <td>0</td> <td>0</td> </tr> </tbody> </table> <p>3553368-2</p>	Field Connection	4 - 20	Optional D01 & D02	Optional AI	Optional AO	Optional DI	Ui =	30 VDC	30 VDC	30 VDC	30 VDC	30 VDC	Ii =	380 mA	500 mA	250 mA	250 mA	380 mA	Pi =	5.32 W	2.5 W	3.8 W	2.0 W	5.32 W	Li =	0	0	0	0	0	CI =	0	23 nF	0	0	0
Field Connection	4 - 20	Optional D01 & D02	Optional AI	Optional AO	Optional DI																																		
Ui =	30 VDC	30 VDC	30 VDC	30 VDC	30 VDC																																		
Ii =	380 mA	500 mA	250 mA	250 mA	380 mA																																		
Pi =	5.32 W	2.5 W	3.8 W	2.0 W	5.32 W																																		
Li =	0	0	0	0	0																																		
CI =	0	23 nF	0	0	0																																		
<p>Nonincendive / Non-sparking</p> <p>CL I, II, III Div 2 Gp A-G T4...T6 CL I, Zone 2 AEx nA IIC T4...T6 Gc Ex nA IIC T4...T6 Gc</p> <p>CL I, Zone 2 AExec IIC T4...T6 Gc Ex ec IIC T4...T6 Gc</p>		<p>Install per Control Drawing 355312</p> <p>Warning: DO NOT OPEN, MAINTAIN, OR SERVICE IN AN AREA WHERE AN EXPLOSIVE ATMOSPHERE MAY BE PRESENT</p> <p>ATMOSPHERE MAY BE PRESENT</p> <ul style="list-style-type: none"> - Substitutions of components may impair intrinsic safety - Cable, cable guard, or conductors in conduit should have insulation rated for at least 18K above the maximum expected ambient temperature of the environment or installation <p>AVERTISSEMENT:</p> <ul style="list-style-type: none"> - La substitution de composants peut compromettre la sécurité intrinsèque - NE PAS OUVRI, MAINTENIR OU SERVIR DANS UNE ZONE OU UNE ATMOSPHERE EXPLOSIVE PEUT ÊTRE PRÉSENTE 																																					

FLOWERVE Logix 3800 Series Digital Positioner

1350 N. MOUNTAIN SPRINGS PKWY
SPRINGVILLE UT, 84603 USA



18-AV480-0101X
18-AV480-0102X

<p>Ex FM16ATEX0096X</p> <p>II 2 G Ex db IIC T4...T6, Gb II 1 G Ex ia IIC T4...T6, Ga II 2 G Ex ib IIC T4...T6, Gb</p> <p>II 2 D Ex tb IIIC T105°C, Db Ta = -55°C to +85°C</p> <p>II 1 D Ex ia IIIC T₂₀₀156°C Da Ta = -55°C to +85°C</p>	<p>IECEx FMG 16.0039X</p> <p>Ex db IIC T4...T6, Gb Ex ia IIC T4...T6, Ga Ex ib IIC T4...T6, Gb Ex ic IIC T4...T6, Gc Ex nA IIC T4...T6, Gc Ex ec IIC T4...T6, Gc</p> <p>Ex tb IIIC T105°C, Db Ta = -55°C to +85°C</p> <p>Ex ia IIIC T₂₀₀156°C Da Ta = -55°C to +85°C</p>	<p>Max Air Supply</p> <p>Pressure 150 psi Rated 30V, 4-20mA TYPE 4x, IP66</p> <p>T4 (-55°C < Tamb < +85°C) T5 (-55°C < Tamb < +60°C) T6 (-55°C < Tamb < +45°C)</p> <p>Mark the check boxes provided as installed. One marked they cannot be changed.</p>	<p>Logix 3800 Entity Parameters</p> <table border="1"> <thead> <tr> <th>Field Connection</th> <th>4 - 20</th> <th>Optional D01 & D02</th> <th>Optional AI</th> <th>Optional AO</th> <th>Optional DI</th> </tr> </thead> <tbody> <tr> <td>Ui =</td> <td>30 VDC</td> <td>30 VDC</td> <td>30 VDC</td> <td>30 VDC</td> <td>30 VDC</td> </tr> <tr> <td>Ii =</td> <td>380 mA</td> <td>500 mA</td> <td>250 mA</td> <td>250 mA</td> <td>380 mA</td> </tr> <tr> <td>Pi =</td> <td>5.32 W</td> <td>2.5 W</td> <td>3.8 W</td> <td>2.0 W</td> <td>5.32 W</td> </tr> <tr> <td>Li =</td> <td>0</td> <td>0</td> <td>0</td> <td>0</td> <td>0</td> </tr> <tr> <td>CI =</td> <td>0</td> <td>23 nF</td> <td>0</td> <td>0</td> <td>0</td> </tr> </tbody> </table> <p>3553363-3</p>	Field Connection	4 - 20	Optional D01 & D02	Optional AI	Optional AO	Optional DI	Ui =	30 VDC	30 VDC	30 VDC	30 VDC	30 VDC	Ii =	380 mA	500 mA	250 mA	250 mA	380 mA	Pi =	5.32 W	2.5 W	3.8 W	2.0 W	5.32 W	Li =	0	0	0	0	0	CI =	0	23 nF	0	0	0
Field Connection	4 - 20	Optional D01 & D02	Optional AI	Optional AO	Optional DI																																		
Ui =	30 VDC	30 VDC	30 VDC	30 VDC	30 VDC																																		
Ii =	380 mA	500 mA	250 mA	250 mA	380 mA																																		
Pi =	5.32 W	2.5 W	3.8 W	2.0 W	5.32 W																																		
Li =	0	0	0	0	0																																		
CI =	0	23 nF	0	0	0																																		
<p>Ex FM16ATEX0098X</p> <p>II 3 G Ex nA IIC T4...T6, Gc II 3 G Ex ic IIC T4...T6, Gc II 3 G Ex ec IIC T4...T6, Gc</p>	<p>See Manual LGENIM0112 for user instructions</p> <p>Warning: DO NOT OPEN, MAINTAIN, OR SERVICE IN AN AREA WHERE AN EXPLOSIVE ATMOSPHERE MAY BE PRESENT</p> <p>ATMOSPHERE MAY BE PRESENT</p> <ul style="list-style-type: none"> - To prevent ignition of flammable or combustible atmospheres disconnect the power before servicing - Substitutions of components may impair intrinsic safety - Cable, cable guard, or conductors in the conduit should have insulation rated for at least 18K above the maximum expected ambient temperature of the environment or installation - Contact Flowserve for Flame Path information 																																						

FLOWERVE Logix 3800 Series Digital Positioner

1350 N. MOUNTAIN SPRINGS PKWY
SPRINGVILLE UT, 84603 USA



18-AV480-0101X
18-AV480-0102X

<p>Ex FM16ATEX0096X</p> <p>II 2 G Ex db IIC T4...T6, Gb II 1 G Ex ia IIC T4...T6, Ga II 2 G Ex ib IIC T4...T6, Gb</p> <p>II 2 D Ex tb IIIC T105°C, Db Ta = -55°C to +85°C</p> <p>II 1 D Ex ia IIIC T₂₀₀156°C Da Ta = -55°C to +85°C</p>	<p>IECEx FMG 16.0039X</p> <p>EX db IIC T4...T6, Gb EX ia IIC T4...T6, Ga EX ib IIC T4...T6, Gb EX ic IIC T4...T6, Gc EX nA IIC T4...T6, Gc</p> <p>EX tb IIIC T105°C, Db Ta = -55°C to +85°C</p> <p>EX ia IIIC T₂₀₀156°C Da Ta = -55°C to +85°C</p>	<p>Max Air Supply</p> <p>Pressure 150 psi Rated 30V, 4-20mA TYPE 4x, IP66</p> <p>T4 (-55°C < Tamb < +85°C) T5 (-55°C < Tamb < +60°C) T6 (-55°C < Tamb < +45°C)</p> <p>Mark the check boxes provided as installed. One marked they cannot be changed.</p>	<p>Logix 3800 FISCO Field Device</p> <table border="1"> <thead> <tr> <th>Field Connection</th> <th>FF</th> </tr> </thead> <tbody> <tr> <td>Ui (V max) =</td> <td>30 VDC</td> </tr> <tr> <td>Ii (I max) =</td> <td>380 mA</td> </tr> <tr> <td>Pi (P max) =</td> <td>5.32 W</td> </tr> <tr> <td>Li =</td> <td>0</td> </tr> <tr> <td>CI =</td> <td>0</td> </tr> </tbody> </table> <p>3559480-3</p>	Field Connection	FF	Ui (V max) =	30 VDC	Ii (I max) =	380 mA	Pi (P max) =	5.32 W	Li =	0	CI =	0
Field Connection	FF														
Ui (V max) =	30 VDC														
Ii (I max) =	380 mA														
Pi (P max) =	5.32 W														
Li =	0														
CI =	0														
<p>Ex FM16ATEX0098X</p> <p>II 3 G Ex nA IIC T4...T6, Gc II 3 G Ex ic IIC T4...T6, Gc II 3 G Ex ec IIC T4...T6, Gc</p>	<p>See Manual LGENIM0112 for user instructions</p> <p>Warning: DO NOT OPEN, MAINTAIN, OR SERVICE IN AN AREA WHERE AN EXPLOSIVE ATMOSPHERE MAY BE PRESENT</p> <p>ATMOSPHERE MAY BE PRESENT</p> <ul style="list-style-type: none"> - To prevent ignition of flammable or combustible atmospheres disconnect the power before servicing - Substitutions of components may impair intrinsic safety - Cable, cable guard, or conductors in the conduit should have insulation rated for at least 18K above the maximum expected ambient temperature of the environment or installation - Contact Flowserve for Flame Path information 														

Figure 6: Certification Labels (Explosion Proof Housing)

FLOWSERVE Logix 3800 Series Digital Positioner

1350 N. MOUNTAIN SPRINGS PKWY
SPRINGVILLE UT, 84663 USA

CE FM APPROVED Ex US Certificate: FM16U S0332X
Canada Certificate: FM16CA0165X

<p>Explosion Proof / Dust Ignition Proof</p> <p><input type="checkbox"/> CL I, Div 1, Gp B-D T4...T6 CL II, Div 1, Gp E-G T4...T6 <input type="checkbox"/> CL III T4 (-40°C < Tamb < +85°C) T5 (-40°C < Tamb < +60°C) T6 (-40°C < Tamb < +45°C)</p> <p>Warning: Conduit required within 18" of entrance</p> <p><input type="checkbox"/> CL I, Zone 1, AEx db IIC T4...T6 Gb Ex db IIC T4...T6 Gb T4 (-50°C < Tamb < +85°C) T5 (-50°C < Tamb < +60°C) T6 (-50°C < Tamb < +45°C)</p> <p><input type="checkbox"/> Zone 21, AEx tb IIC, T105°C (-50°C < Tamb < +85°C)</p>	<p>FM16A TEX0096X</p> <p><input type="checkbox"/> II 2 G Ex db IIC T4...T6, Gb T4 Ta = -55°C to +85°C T5 Ta = -55°C to +60°C T6 Ta = -55°C to +45°C</p> <p><input type="checkbox"/> II 2 D Ex tb IIC T105°C, Db (-55°C < Tamb < +85°C)</p>	<p>IECEX FMG 16.0039X</p> <p><input type="checkbox"/> Ex db IIC T4...T6, Gb Ex tb IIC T105°C, Db (-55°C < Tamb < +85°C)</p> <p><input type="checkbox"/> Ex nA IIC T4...T6, Gc <input type="checkbox"/> Ex ec IIC T4...T6 Gc</p> <p>T4 Ta = -55°C to +85°C T5 Ta = -55°C to +60°C T6 Ta = -55°C to +45°C</p>	<p>Max Air Supply Pressure 150 psi Rated 30V, 4-20mA TYPE 4x, IP66</p> <p>Mark the check boxes provided as installed. Once marked they cannot be changed.</p> <p>Warning: DO NOT OPEN, MAINTAIN, OR SERVICE IN AN AREA WHEREAN EXPLOSIVE ATMOSPHERE MAY BE PRESENT</p> <p>Cable, cable guard, or conductors in conduit should have insulation rated for at least 18K above the maximum expected ambient temperature of the environment or installation</p> <p>AVERTISSEMENT: - NE PAS OUVRI, MAINTENIR OU SERVIR DANS UNE ZONE OU UNE ATMOSPHERE EXPLOSIVE PEUT ETRE PRESENTE</p>
<p>Nonincendive / Non-sparking</p> <p><input type="checkbox"/> CL I, II, III Div 2 Gp A-G T4...T6 CL I, Zone 2 AEx nA IIC T4...T6 Gc <input type="checkbox"/> Ex nA IIC T4...T6 Gc</p> <p><input type="checkbox"/> CL I, Zone 2 AEx ec IIC T4...T6 Gc <input type="checkbox"/> Ex ec IIC T4...T6 Gc</p> <p>T4 (-50°C < Tamb < +85°C) T5 (-50°C < Tamb < +60°C) T6 (-50°C < Tamb < +45°C)</p>			

Figure 7: Certification Labels

Logix 3800 Series Digital Positioner

MODEL: 3820-14EA-**D 4 0 0 - 0 0 0 0 - 00**

SERIAL: C911002S

HW Rev: BETA

SW Rev: BETA

SUPPORT
Americas +1 801 489-2300
EMA +43 (0) 4242 41181 999
Asia + (65) 6879 8900
digitalproductstac@flowserve.com

D	4	0	0	-	0	0	0	0	-	00
DOUBLE ACTING STD	4-WAY, DOUBLE ACTING	NO GAUGE	NO GAUGE		STD DIAGNOSTICS	NO LCD	NO FEEDBACK SHAFT	STD MOUNTING		NO SPECIAL OPTIONS

Figure 8: Model Code Label



Logix 3800 Series Digital Positioner



1350 N. MOUNTAIN SPRINGS PKWY
SPRINGVILLE UT, 84663 U.S.A.

Max Supply Pressure 150 psi, Rated 30V, 4-20mA

2809

GYJ18.1187X

18-AV480-0101X
18-AV480-0102X

- Ex FM16ATEX0096X**
- II 1 G Ex ia IIC T4...T6, Ga
 - II 2 G Ex ib IIC T4...T6, Gb
T4 Ta = -55°C to +85°C
T5 Ta = -55°C to +60°C
T6 Ta = -55°C to +45°C
 - II 2 D Ex tb IIC T105, Db
Ta = -55°C to +85°C
 - II 1 D Ex ia IIC T200 156°C Da
Ta = -55°C to +85°C
- Ex FM16ATEX0098X**
- II 3 G Ex nA IIC T4...T6, Gc
 - II 3 G Ex ic IIC T4...T6, Gc
 - II 3 G Ex ec IIC T4...T6, Gc
T4 Ta = -55°C to +85°C
T5 Ta = -55°C to +60°C
T6 Ta = -55°C to +45°C

- IECEx FMG 16.0039X**
- Ex ia IIC T4...T6, Ga
 - Ex ib IIC T4...T6, Gb
 - Ex ic IIC T4...T6, Gc
 - Ex nA IIC T4...T6, Gc
 - Ex ec IIC T4...T6, Gc
T4 Ta = -55°C to +85°C
T5 Ta = -55°C to +60°C
T6 Ta = -55°C to +45°C
 - Ex tb IIC T105°C, Db
Ta = -55°C to +85°C
 - Ex ia IIC T200 156°C Da
Ta = -55°C to +85°C

367893-3

Intrinsically Safe / Non-Incendive
US Certificate FM16US0332X Canada Certificate FM16CA0165X

<input type="checkbox"/> CL I, II, III Div 1 Gp A-G T6...T4 <input type="checkbox"/> CL I, Zone 0, AEx ia IIC T6...T4 Ga Ex ia IIC T6...T4 Ga <input type="checkbox"/> CL I, Zone 1, AEx ib IIC T6...T4 Gb Ex ib IIC T6...T4 Gb <input type="checkbox"/> CL I, Zone 2, AEx ic IIC T6...T4 Ga Ex ic IIC T6...T4 Gc <input type="checkbox"/> Zone 20, AEx ia IIC T156°C Da <input type="checkbox"/> Ex ia IIC T156°C Da (-55°C < Tamb < +85°C)	<input type="checkbox"/> CL I, II, III Div 2 Gp A-G T4...T6 <input type="checkbox"/> CL I, Zone 2 AEx nA IIC T4...T6 Gc <input type="checkbox"/> Ex nA IIC T4...T6 Gc <input type="checkbox"/> CL I, Zone 2 AEx ec IIC T4...T6 Gc <input type="checkbox"/> Exec IIC T4...T6 Gc T4 (-55°C < Tamb < +85°C) T6 (-55°C < Tamb < +60°C) T6 (-55°C < Tamb < +45°C)
---	---

See Manual LGENIM0112 for user instructions
Install per Control Drawing 355312
 Warning: Do not open, maintain, or service in area where explosive atmosphere may be present
 To prevent ignition of flammable or combustible atmospheres disconnect the power.
 Substitutions of components may impair Intrinsic Safety Cable, cable guard, or conductors in the conduit should have insulation rated for at least 18k above the maximum expected ambient temperature of the environment or installation.

Logix 3800 Entity Parameters

Field Connection	4 - 20	Optional D01 & D02	Optional AI	Optional A0	Optional DI
Ui =	30 VDC	30 VDC	30 VDC	30 VDC	30 VDC
Ii =	380 mA	500 mA	250 mA	250 mA	380 mA
Pi =	5.32 W	2.5 W	3.8 W	2.0 W	5.32 W
Li =	0	0	0	0	0
Ci =	0	23 nF	0	0	0



Logix 3800 Series Digital Positioner



1350 N. MOUNTAIN SPRINGS PKWY
SPRINGVILLE UT, 84663 U.S.A.

Max Supply Pressure 150 psi, Rated 30V, 4-20mA

2809

GYJ18.1187X

18-AV480-0101X
18-AV480-0102X

- Ex FM16ATEX0096X**
- II 1 G Ex ia IIC T4...T6, Ga
 - II 2 G Ex ib IIC T4...T6, Gb
T4 Ta = -55°C to +85°C
T5 Ta = -55°C to +60°C
T6 Ta = -55°C to +45°C
 - II 2 D Ex tb IIC T105°C, Db
Ta = -55°C to +85°C
 - II 1 D Ex ia IIC T200 156°C Da
Ta = -55°C to +85°C
- Ex FM16ATEX0098X**
- II 3 G Ex nA IIC T4...T6, Gc
 - II 3 G Ex ic IIC T4...T6, Gc
 - II 3 G Ex ec IIC T4...T6, Gc
T4 Ta = -55°C to +85°C
T5 Ta = -55°C to +60°C
T6 Ta = -55°C to +45°C

- IECEx FMG 16.0039X**
- EX ia IIC T4...T6, Ga
 - EX ib IIC T4...T6, Gb
 - EX ic IIC T4...T6, Gc
 - Ex nA IIC T4...T6, Gc
 - Ex ec IIC T4...T6, Gc
T4 Ta = -55°C to +85°C
T5 Ta = -55°C to +60°C
T6 Ta = -55°C to +45°C
 - Ex tb IIC T105°C, Db
Ta = -55°C to +85°C
 - Ex ia IIC T200 156°C Da
Ta = -55°C to +85°C

367894-3

Intrinsically Safe / Non-Incendive
US Certificate FM16US0332X Canada Certificate FM16CA0165X

<input type="checkbox"/> CL I, II, III Div 1 Gp A-G T6...T4 <input type="checkbox"/> CL I, Zone 0, AEx ia IIC T6...T4 Ga Ex ia IIC T6...T4 Ga <input type="checkbox"/> CL I, Zone 1, AEx ib IIC T6...T4 Gb Ex ib IIC T6...T4 Gb <input type="checkbox"/> CL I, Zone 2, AEx ic IIC T6...T4 Ga Ex ic IIC T6...T4 Gc <input type="checkbox"/> Zone 20, AEx ia IIC T156°C Da <input type="checkbox"/> Ex ia IIC T156°C (-55°C < Tamb < +85°C)	<input type="checkbox"/> CL I, II, III Div 2 Gp A-G T4...T6 <input type="checkbox"/> CL I, Zone 2 AEx nA IIC T4...T6 Gc <input type="checkbox"/> Ex nA IIC T4...T6 Gc <input type="checkbox"/> CL I, Zone 2 AEx ec IIC T4...T6 Gc <input type="checkbox"/> Ex ec IIC T4...T6 Gc T4 (-55°C < Tamb < +85°C) T6 (-55°C < Tamb < +60°C) T6 (-55°C < Tamb < +45°C)
--	--

See Manual LGENIM0112 for user instructions
Install per Control Drawing 355312
 Warning: Do not open, maintain, or service in area where explosive atmosphere may be present
 To prevent ignition of flammable or combustible atmospheres disconnect the power.
 Substitutions of components may impair Intrinsic Safety Cable, cable guard, or conductors in the conduit should have insulation rated for at least 18k above the maximum expected ambient temperature of the environment or installation.

Logix 3800 FISCO Field Device

Field Connection	FF
Ui (V max) =	9 - 30 V
Ii (I max) =	30 VDC
Pi (P max) =	380 mA
Li =	5.32 W
Ci =	0

Figure 9: Certification Labels (Intrinsically Safe Housing)

4 INSTALLATION – MOUNTING

NOTE: The Logix 3800 positioner can be mounted in any orientation - with gauges on the left or right.

4.1 Mounting to Mark One Linear Valves

To attach a Logix 3800 positioner to a Valtek linear Mark I valve, refer to Figure 10: Mounting to Mark I Linear Valve and proceed as outlined below. Refer to Figure 11: Mounting Namur to Linear Valve if using a Namur shaft. Refer to, APPENDIX G - HOW TO ORDER, for complete linear actuator mounting kit listings.

- 1 Remove washer and nut from follower pin assembly. Insert pin into the appropriate hole in follower arm, or locate the pin along the slot in the follower arm based on stroke length. The stroke lengths are located on the follower arm. Make sure the stamped side of the arm is toward the unthreaded end of the pin. Reinstall the lock washer and tighten the nut to complete follower arm assembly.
 - 2 Slide the slot in the follower arm assembly over the flats on the positioner feedback shaft on the back of the positioner. The follower arm will be specific to a D shaft or a Namur shaft. Rotate the arm until the arm is pointing toward the side of the positioner with ports A, B, and Supply. Slide the lock washer over the threads on the shaft and tighten down the nut.
- NOTE:** The feedback shaft has a clutch mechanism that allows for over-rotation of the shaft for easy adjustments.
- 3 Align the bracket with the three outer mounting holes on the positioner. Fasten with 5/16-18 UNC bolts.

- 4 Screw one mounting bolt into the hole on the yoke mounting pad nearest the cylinder. Stop when the bolt is approximately 3/16" from being flush with the mounting pad.
- 5 Slip the large end of the slotted mounting hole in the back of the positioner/bracket assembly over the mounting bolt. Slide the small end of the teardrop under the mounting bolt and align the lower mounting hole.
- 6 Insert the lower mounting bolt and tighten the bolting.
- 7 Position the take-off arm mounting slot against the stem clamp mounting pad. Apply Loctite 222 to the take-off arm bolting and insert through washers into stem clamp. Leave bolts loose.
- 8 Center the take-off arm on the follower pin.
- 9 Align the take-off arm with the top surface of the stem clamp and tighten bolt. Torque to 120 in-lb.

NOTE: If mounted correctly, the follower arm should be horizontal when the valve is at 50% stroke and should move approximately $\pm 30^\circ$ from horizontal over the full stroke of the valve. A stroke calibration error will occur if the positioner is mounted incorrectly, and the indicator lights will blink a RRYG code indicating the position sensor has gone out of range on one end of travel, or the travel is too small. Reposition the feedback linkage or the positioner to correct the error.

NOTE: To virtually eliminate non-linearity, use the Linearization feature in the Custom Characterization page of the DTM.

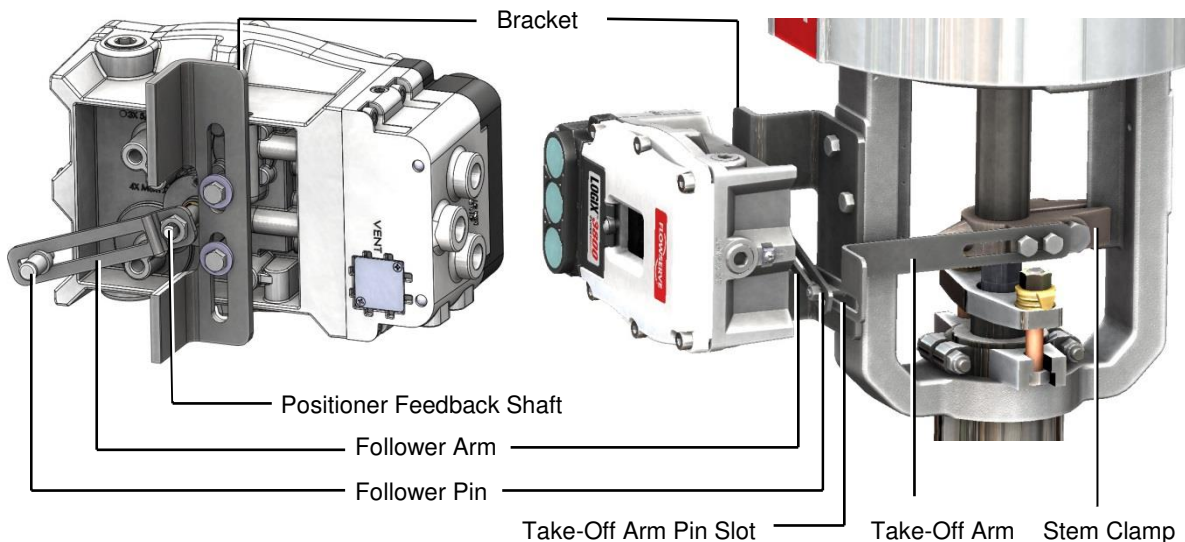

Figure 10: Mounting to Mark I Linear Valve

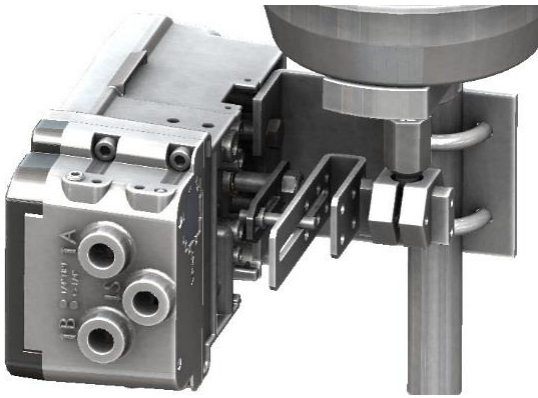

Figure 11: Mounting Namur to Linear Valve

4.2 Mounting to Standard Valtek Rotary Valves

The standard rotary mounting applies to Valtek valve/actuator assemblies that do not have mounted volume tanks or hand-wheels. The standard mounting uses a linkage directly coupled to the valve shaft. This linkage has been designed to allow for minimal misalignment between the positioner and the actuator. Refer to Figure 12: Valtek Rotary Follower Arm through Figure 15: Valtek Rotary Final Orientation.

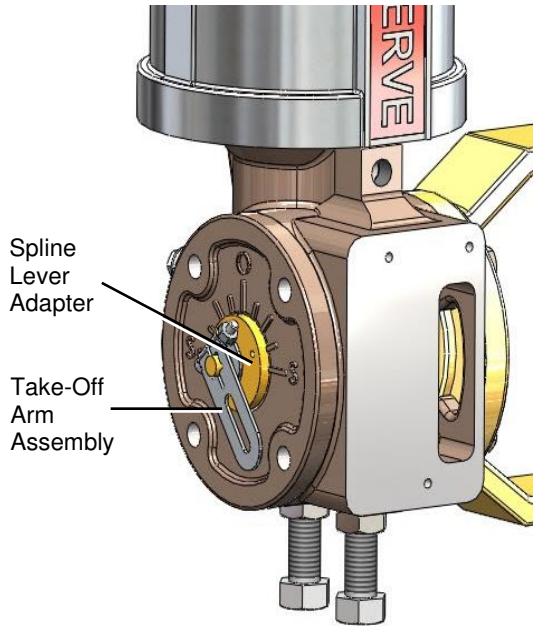

Figure 13: Valtek Rotary Take Off Arm

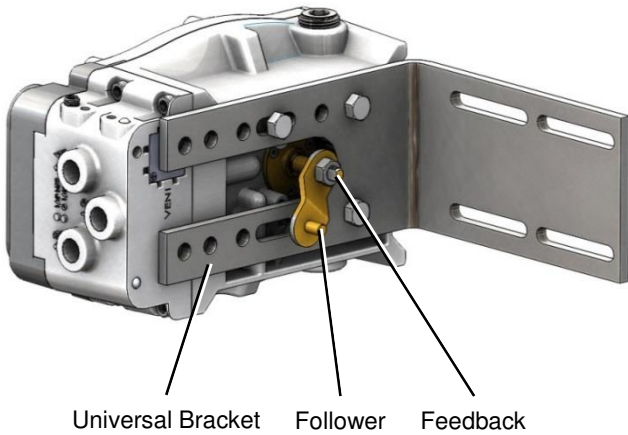

Figure 12: Valtek Rotary Follower Arm



Figure 14: Valtek Rotary Mounting

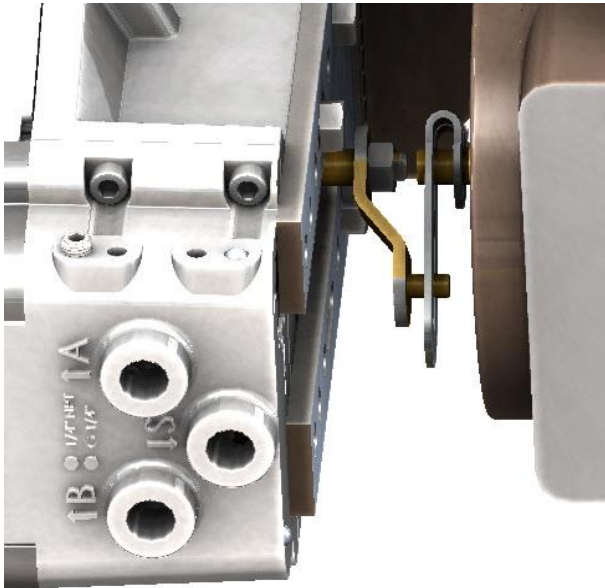

Figure 15: Valtek Rotary Final Orientation

- 1 Fasten the spline lever adapter to the splined lever using two 4-40 screws.
- 2 Slide the take-off arm onto the spline lever adapter shaft, orienting the arm to the current valve position. Insert the screw with star washer through the take-off arm and add the second star washer and nut and tighten.
- 3 Attach follower arm to positioner feedback shaft using the 10-32 nut.
- 4 Rotate the follower arm so that the follower pin will slide into the slot on the take-off arm. Adjust the bracket position as needed noting the engagement of the follower pin and the take-off arm slot. The pin should extend approximately 2 mm past the take-off arm. When properly adjusted, securely tighten the bracket bolts.
- 5 Using three 5/16-18 UNC x 1/2" bolts, fasten positioner to the universal bracket.
- 6 Using a 1/2" end wrench and two 5/16-18 UNC X 1/2" bolts, attach the bracket to actuator transfer case pad. Leaving these bolts slightly loose will aid in final adjustments.
- 7 Rotate follower arm so the follower pin will slide into the slot on the take-off arm. Over-rotate the follower arm if needed, so the arm moves freely through the intended travel.

NOTE: The feedback shaft has a clutch mechanism that allows for over-rotation of the shaft for easy adjustments.

- 8 Adjust the bracket position as needed noting the engagement of the follower pin and the take-off arm slot. The pin should extend approximately 1/16" past the take-off arm. When properly adjusted, securely tighten the bracket bolts.

- 9 If calibration fails, retry the calibration. Exceeding the feedback values will cause it to continue to fail, and the arm must be adjusted away from the positioner's limits. Rotate the feedback shaft so that the full free travel of the feedback shaft is in the range of the actuator movement. Optionally, continue to attempt the calibration. Each calibration attempt adjusts the acceptable limits, and it should eventually pass.

CAUTION: Remember to remove the air supply before re-adjusting take-off arm.

NOTE: If mounted correctly to a standard valve, the follower arm should be horizontal when the valve is at 50% stroke and should move approximately ±30° from horizontal over the full stroke of the valve.

NOTE: To improve linearity of feedback, use the Linearization feature on the Custom Characterization page of the DTM.

4.3 Mounting to MaxFlo Rotary Valves

- 1 Slide the take-off arm onto the shaft. Insert the screw with the star washer through the take-off arm and add the second star washer and nut. Tighten the nut with a socket, so the arm is just snug on the shaft but still able to rotate. Tightening will occur after linkage is correctly oriented. Refer to Figure 16: MaxFlo Take Off Arm.

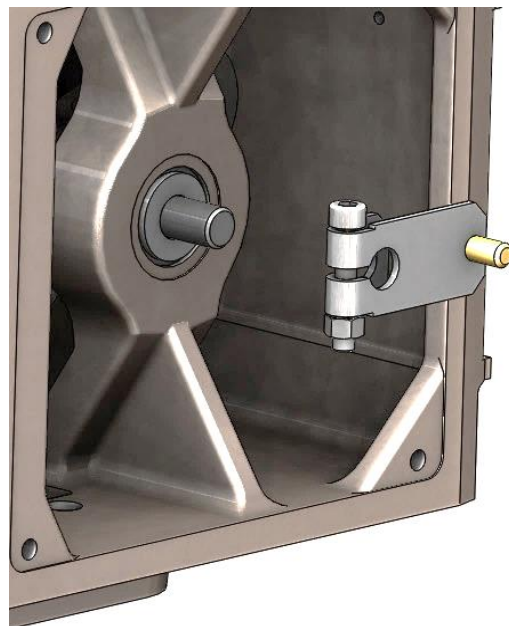

Figure 16: MaxFlo Take Off Arm

- 2 Attach the mounting plate to the positioner using four screws and attach follower arm to positioner feedback shaft. See Figure 17: MaxFlo Follower Arm and Figure 18: MaxFlo Connection.

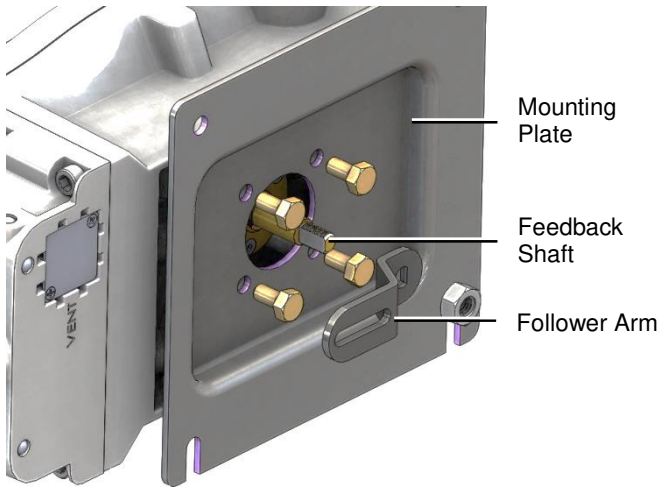

Figure 17: MaxFlo Follower Arm



Figure 18: MaxFlo Connection

- 3 Rotate the follower arm so that the take-off pin will slide into the slot on the follower arm. Adjust the bracket position as needed noting the engagement of the follower pin and the take-off arm slot. The pin should extend approximately 2 mm past the take-off arm. When properly adjusted, securely tighten the bracketing bolts. See Figure 19: MaxFlo Assembly.

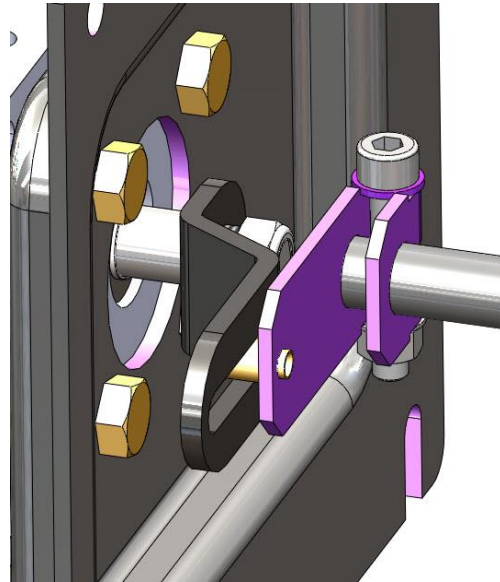

Figure 19: MaxFlo Assembly

NOTE: The feedback shaft has a clutch mechanism that allows for over-rotation of the shaft for easy adjustments.

- 4 If calibration fails, retry the calibration. If it still fails, remove power from the positioner, disconnect the air, and then reconnect the positioner and continue to attempt the calibration. Each calibration attempt adjusts the acceptable limits, and it should pass eventually.

4.4 Mounting to Rotary NAMUR Valves

- 1 Attach the mounting plate to the positioner using four screws. See Figure 20: AutoMax Bracket.

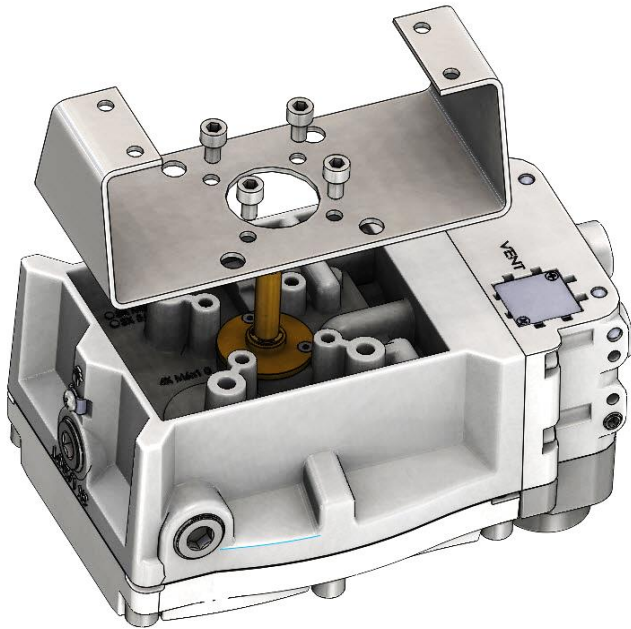

Figure 20: AutoMax Bracket

- 2 Rotate the feedback shaft to match the orientation of the receiver on the actuator.

NOTE: *The feedback shaft has a clutch mechanism that allows for over-rotation of the shaft for easy adjustments.*

- 3 Mount the positioner onto the actuator using the washers and nuts as shown in Figure 21: AutoMax Assembly and Figure 22: MaxFlo 4 Assembly.
- 4 If calibration fails, retry the calibration. If it still fails, remove power from the positioner, disconnect the air, and then reconnect the positioner and continue to attempt the calibration. Each calibration attempt adjusts the acceptable limits, and it should eventually pass.

CAUTION: *Remember to remove the air supply before re-adjusting take-off arm.*



Figure 21: AutoMax Assembly

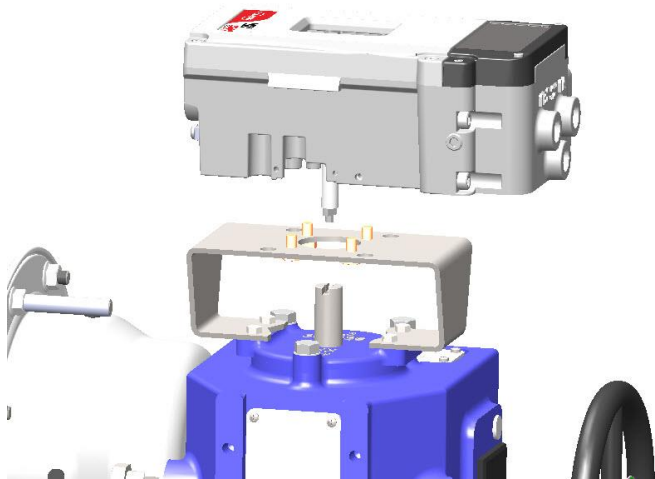

Figure 22: MaxFlo 4 Assembly

4.5 Direct Mount

Direct mount allows the positioner to be mounted directly to the actuator without tubing. See your Flowserve sales representative for actuator options.

- 1 Assemble the direct mount block onto the positioner. See figure 23.
- 2 Ensure the feedback shaft and take-off arm are properly aligned.
- 3 If the actuator is designed as an ATO system, remove the plug from the positioner's direct air port, and insert a 1/4" plug into positioner ports A and B.
- 4 Mount the positioner assembly to the actuator that is compatible with Flowserve direct mount devices.

4



Figure 23: Direct Mount on IS Housing

5 INSTALLATION - TUBING

After mounting to the actuator, tube the positioner using the appropriate compression fitting connectors. For best performance, use 10 mm (3/8 inch) tubing for 645 square cm (100 square inches) actuators or larger.

5.1 Determine Air Action

When an air supply is present, and the relay is energized, port “A” delivers air. Typically, the tubing from port “A” is connected to side of the actuator that results in the air compressing the actuator spring. When tubed this way, the spring is designed to return the valve to the fail-safe state should supply air or power to the unit fail or be turned off.

Tube the port labeled “A” to the side of the actuator that must receive air to begin moving away from the fail-safe state.

If air from “A” should open the valve, set the Air Action configuration DIP switch on the positioner to Air-to-Open, otherwise set it to Air-to-Close. The Air-to-Open and Air-to-Close selection is only a reflection of the tubing. When selecting air action during configuration, the selection tells the control which way the actuator was tubed.

If the valve is double acting, port the valve labeled “B” to the other side of the actuator, otherwise plug port “B”.

DANGER: Proper tubing orientation is critical for the positioner to function correctly and have the correct failure mode. The backward tubing could cause an unsafe failure mode.

Example: Tubing Linear Double-Acting Actuators

For a linear air-to-open actuator, the tubing from port “A” is connected to the bottom side of the actuator (closest to the valve). Tube the “B” port of the positioner to the top side of the actuator. See Figure 24: Linear, Double Acting, Air to Open. For a linear air-to-close actuator the tubing configuration is reversed.

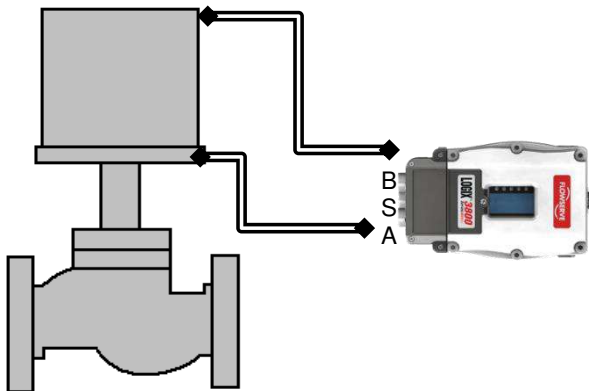

Figure 24: Linear, Double Acting, Air to Open

Example: Rotary Double-Acting Actuators

For a rotary actuator, rout tubing from Port “A” to the far side of the actuator and tubing from port “B” to the side of the actuator closer to the transfer case. Follow this tubing convention regardless of air action. On rotary actuators, the transfer case orientation determines the air action. See Figure 25: Rotary, Double Acting, Air to Open.

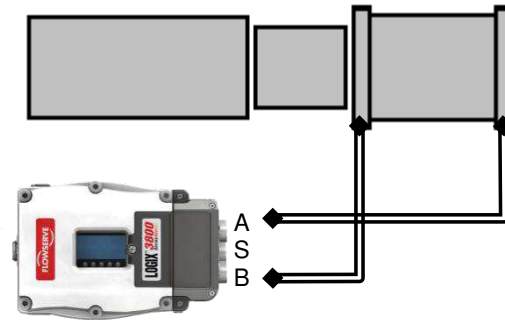

Figure 25: Rotary, Double Acting, Air to Open

Example: Tubing Single-Acting Actuators

For single-acting actuators, tubing for port “A” is always to the pneumatic side of the actuator regardless of air action. Port B is plugged. See Figure 26: Linear, Single Acting, Air to Open.

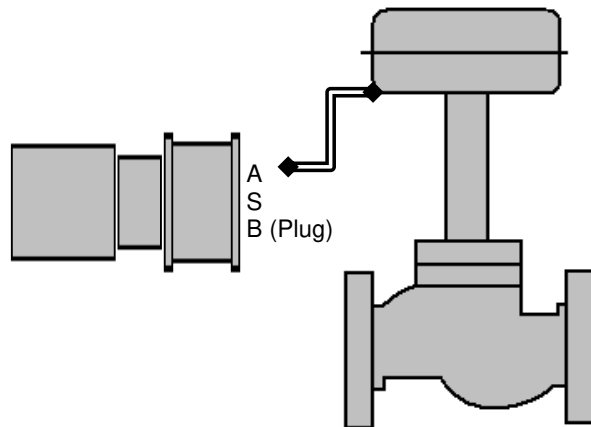

Figure 26: Linear, Single Acting, Air to Open

5.2 Connect Supply Port

The housing indicates the positioner ports’ threads (either G 1/4 or 1/4 NPT).

Always install a coalescing filter in the supply gas line to maintain the recommended air quality. If dirty air is a possibility, always install an air filter. There are small screens installed in the positioner passages, which remove medium and coarse size dirt from the pressurized air. If necessary, they are readily available for cleaning.

If the customer is using the diagnostic features of the Logix 3800, a supply regulator will provide the best result. In applications where the supply pressure is higher than the maximum actuator pressure rating a supply, the regulator is required to lower the pressure to the actuator's maximum rating.

DANGER: Exceeding the maximum actuator supply pressure may cause the actuator to explode, causing death, injury or property damage.

5.3 Purging

Purging allows the non-pressurized side of a single acting actuator to fill with clean exhaust gas instead of moist atmospheric air. This configuration helps prevent corrosion of actuator components in harsh environments. Figure 27 shows the purging configuration. Contact your local FLOWSERVE Representative for more information regarding the purging option.

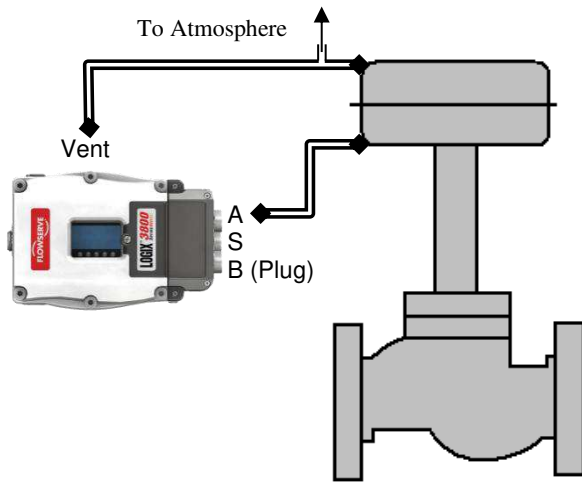

Figure 27: Purging

5.4 Venting

A Logix 3800 positioner is vented directly to the atmosphere. When supply air is substituted with sweet natural gas, piping must be used to route the exhausted natural gas to a safe environment.

The exhaust port is located on the back of the positioner. The port is tapped with a ¼ NPT thread and covered with a protective cap. To control vented gas, remove the cap and connect the necessary tubing/piping to these ports. See Figure 28: Exhaust Vent. Refer to Table 1: Max. Recommended Vent Tubing Length(ft) with 1/2" Dia. Tubing for a list of tubing size recommendations.

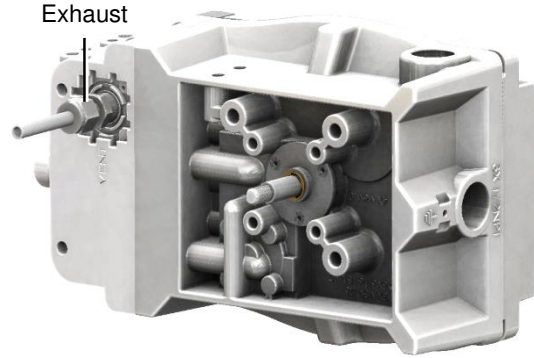

Figure 28: Exhaust Vent

This piping system may cause some positioner back pressure. The maximum allowable back pressure is 0.55 bar g (8.0 PSIG).

NOTE: It is not recommended to use 1/4" Tubing for venting any actuator positioner configuration due to the likelihood of positioner overshoot.

CAUTION: The back pressure in the main housing must never rise above 0.55 bar g (8.0 PSIG). This could cause the positioner to become unresponsive under some circumstances.

Table 1: Max. Recommended Vent Tubing Length(ft) with 1/2" Dia. Tubing

Actuator Size (in ²)	Gain	Supply Pressure (PSI)		
		60	90	120
25	B	100	50	5
	E	25	3	-
100	E	65	25	13

6 INSTALLATION – ELECTRICAL CONNECTIONS (HART)

CAUTION: Connect only wires with compatible electrical signals to the terminals. Voltages or currents outside the specified range can damage the circuit boards.

6.1 Electrical Terminals

Figure 29 shows the terminals on the positioner unit labeled for HART protocol.

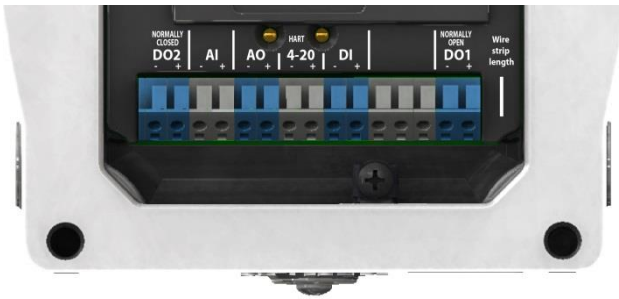

Figure 29: Terminal Diagram (HART)

6.2 Command Input (4-20 mA) Connection

Wire 4-20 mA current source to the input terminal labeled “HART 4-20”. The Logix 3820 has spring loaded terminal blocks that do not require tools. Depending on the current source, a HART filter may be required. See section 13, Maintenance – Troubleshooting.

NOTE: The polarity of the terminals is labeled on the cover; however, the command input connection is polarity insensitive.

6.2.1 Compliance Voltage

Output compliance voltage refers to the maximum voltage the current source can provide. A current loop system consists of the current source, wiring resistance, barrier resistance (if present), and the Logix 3820 impedance.

The Logix 3820 requires that the current loop system allows for a 10 VDC drop across the positioner at maximum loop current. The current loop system should have a minimum compliance voltage greater than 10 VDC and a maximum less than 32 VDC. The current operating range is from 4 to 20 mA. See Figure 30: Compliance Voltage.

To determine if the loop will support the Logix 3820, perform the calculation in the following equation. The Available Voltage must be greater than 10VDC to support the Logix 3820.

Equation 1

$$\text{Available Voltage} = \text{Controller Voltage (@Current}_{max}) - \text{Current}_{max} \times (R_{\text{barrier}} + R_{\text{wire}})$$

Example:

$$\text{Current}_{max} = 20\text{mA}$$

$$R_{\text{barrier}} = 300\Omega$$

$$R_{\text{wire}} = 25\Omega$$

$$\text{Available Voltage} = 19\text{ V} - 0.020\text{ A} \times (300\Omega + 25\Omega)$$

$$\text{Available Voltage} = 12.5\text{ V}$$

The available voltage (12.5 V) is greater than the required voltage (10.0 V) therefore; this system will support the Logix 3820. The Logix 3820 has an input resistance equivalent to 500 Ω at a 20 mA input current.

CAUTION: Always limit the current for 4-20 mA operation. Never connect a voltage source directly across the Logix 3820 terminals. Permanent circuit board damage may occur.

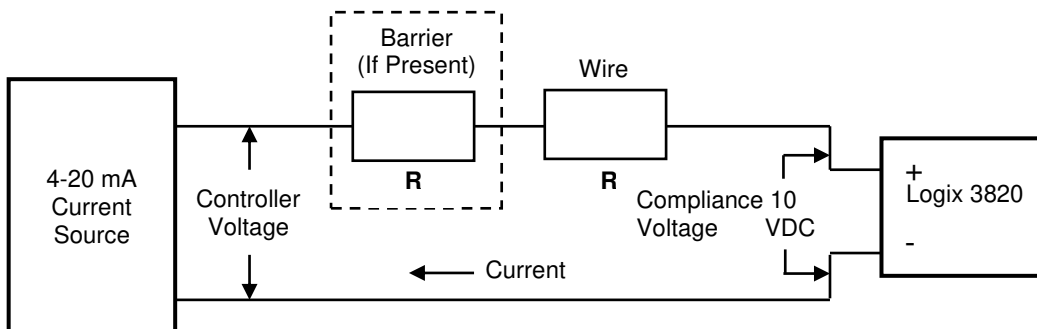

Figure 30: Compliance Voltage

6.2.2 Cable Requirements

The Logix 3820 digital positioner utilizes the HART Communication protocol. It is superimposed on the 4-20 mA current signal. The two frequencies used by the HART protocol are 1200 Hz and 2200 Hz. Calculate cable length restrictions to prevent distortion of the HART communication signal and cable capacitance. The cable length must be limited if the capacitance is too high. Selecting a cable with lower capacitance/foot rating will allow longer cable runs. In addition to the cable capacitance, the network resistance also affects the allowable cable length.

For installation practices and allowable cable lengths refer to the latest version of the HART Field Communications Protocol Application Guide, HART HCF LIT.

NOTE: 24–16 AWG gauge wire sizes should be used for connection to the spring terminals. Wire sizes outside of this gauge range may not form a good connection or may cause damage to the terminals.

The input loop current signal to the Logix 3820 digital positioner should be in shielded cable. By tying shields to ground at only one end of the cable removes environmental and electrical noise. Connect the shield wire to the source, not at the positioner.

6.2.3 Intrinsically Safe Barriers

When selecting an intrinsically safe barrier, make sure the barrier is HART compatible. Contact a FLOWSERVE representative to verify compatibility. Although the barrier will pass the loop current and allow normal positioner control, if not compatible, it may prevent HART communication.

6.2.4 Conduit

This product has three electrical conduit connections in thread size 1/2" NPT. Located near the conduit connection is the thread size for the conduit of the positioner. Conduit fittings must match equipment housing threads before installation. If threads do not match, obtain suitable adapters or contact a FLOWSERVE representative.

6.2.5 Grounding

The grounding terminals, located by the electrical conduit ports should be used to provide the unit with an adequate and reliable earth ground reference. Tie the outer grounding terminal to the same ground as the electrical conduit. Tie the inner grounding terminal to the cable shield.

NOTE: For maximum conducted immunity tie both sides of the shield to a common earth reference.

Figure 31 shows the conduit and grounding connections on the positioner.

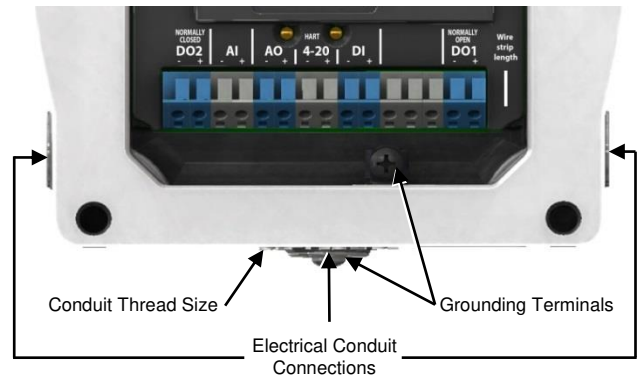

Figure 31: Conduit and Grounding (HART)

6.2.6 Electromagnetic Compatibility

The Logix 3820 digital positioner has been designed, per standards EN61000-4-3 Radiated Immunity and EN55011 Radiated Emissions, to operate correctly in electromagnetic (EM) fields found in typical industrial environments. The following precautions should be taken to adhere to these standards:

- Do not use the positioner in environments with excessively high EM field strengths (i.e. greater than 10 V/m)
- Do not use portable EM devices such as hand-held two-way radios within 30 cm of the device.

Ensure proper wiring and shielding techniques of the control lines, and route control lines away from electromagnetic sources that may cause unwanted electrical noise. To help eliminate noise use an electromagnetic line filter; contact a FLOWSERVE representative for line filter recommendations.

In the event of a severe electrostatic discharge near the positioner, the device should be inspected to ensure correct operability. It may be necessary to recalibrate the Logix 3820 positioner to restore operation.

6.3 Auxiliary I/O Circuits

The Logix 3820 contains the following auxiliary circuits: an Analog Output (AO), an Analog Input (AI), two Discrete Outputs (DO1 & DO2), a Discrete Input (DI), and the Remote Mount. Labels for each connection to each circuit are on the cover adjacent to the terminals.

6.3.1 Analog Output

The Analog Output function produces a 4-20 mA signal that corresponds to the position of the valve. Output follows actual position of the valve, including all failure modes of positioner except the loss of power. An output of < 1.0 mA is transmitted when the positioner loses power.

Calibration of the analog output signal is performed using the display menu, a HART handheld communicator, the ValveSight DTM or the LCD menu.

The AO does not interfere with positioner operation.

The AO signal corresponds with the configuration of the Signal At Closed DIP switch setting. If the valve closes with a four mA signal, the AO will show a four mA signal when closed. If the valve closes with a 20 mA signal, the AO will show a 20 mA signal when closed. This can be changed with an AO calibration.

⚠ CAUTION: Proper ESD precautions must be observed during AO connection to a power supply or loop calibrator to avoid possible personal injury and property damage in the case of an over-voltage incident. Perform the following precautions prior to connecting the AO to power: ground the positioner, ground the power supply source and ground the technician performing the connection.

🔍 NOTE: The AO has an internal fuse. In the event of a surge this fuse could be damaged and leave the AO nonfunctional.

For AO function connect AO terminals in series with a 10 to 40 VDC power supply, including a method to determine the current. The AO current will follow the valve position and will have a range of 4-20mA. See Figure 32 for more info.

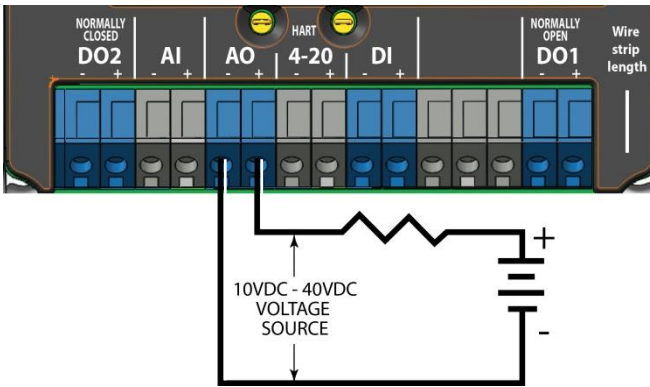

Figure 32: Analog Output Circuit

6.3.2 Auxiliary Analog Input

The AI circuit requires that the current loop system allows for a 10 VDC drop across the positioner at maximum loop current. The current operating range is from 4 to 20 mA. See Figure 33 for more details.

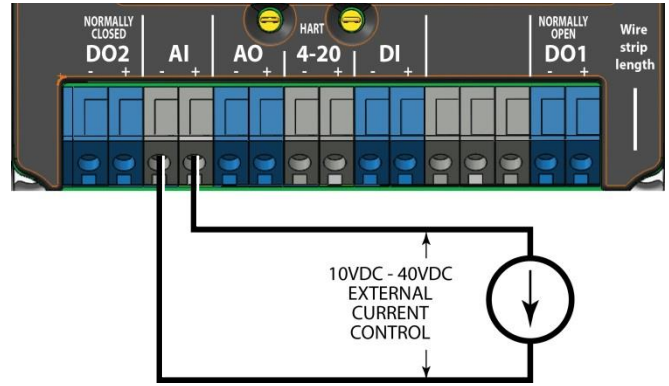

Figure 33: Auxiliary Analog Input Circuit

6.3.3 Discrete Output 1

Use the Discrete Output function to indicate a variety of conditions such as alarms, warnings, position limits, etc. The current is normally low and goes high when one of the pre-configured states occurs.

The configuration of the discrete output signal is done using the ValveSight DTM or push-buttons.

The DO does not interfere with positioner operation.

The DO complies with DIN 19234.

To enable DO function, wire the Logix 3820 DO terminals in series with a 7 to 40 VDC power supply. Include a method to limit, and measure the current, such as a resistor or a NAMUR switch amplifier designed for this purpose. There is a maximum 500mA rating for the DO circuit.

In this circuit the current will remain high until the user-defined condition (alarm) is active, and then drop low when tripped. See Figure 34 for more detail.

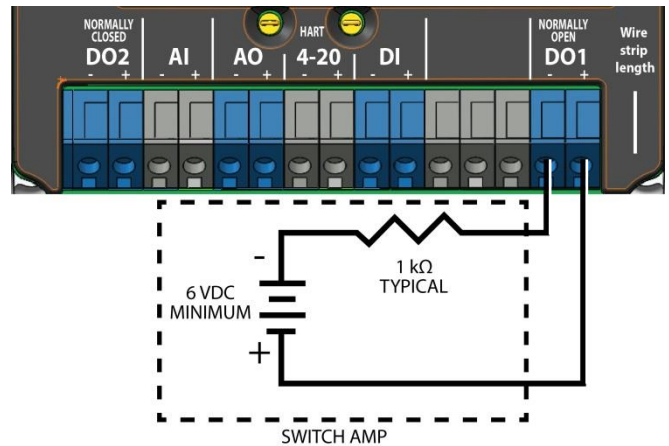

Figure 34: Discrete Output 1 Circuit

6.3.4 Discrete Output 2

Discrete Output 2 serves the same function as Discrete Output 1, but it is normally closed. See Figure 35 for more details.

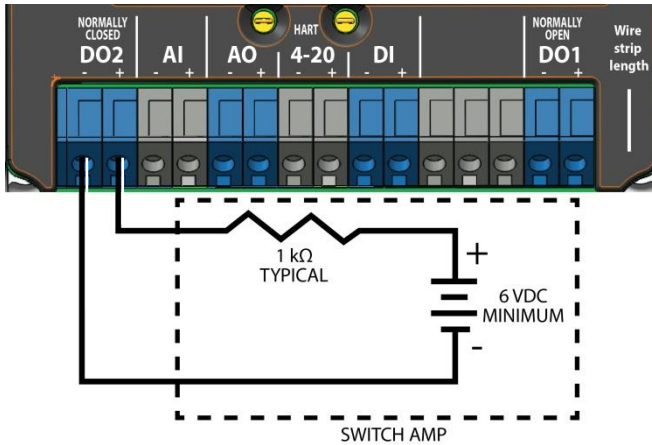

Figure 35: Discrete Output 2 Circuit

6.3.5 Discrete Input

Use the Discrete Input to signal the positioner to begin a partial stroke test, or move to a predefined position as long as the signal remains.

Supply a low voltage (or no voltage) to indicate a normal state. Raise the voltage to indicate the tripped state.

The configuration of the discrete output signal is done using the display menu, a HART handheld Communicator, or the ValveSight DTM.

CAUTION: During the use of the Discrete Input function, the valve may stroke unexpectedly. Follow internal procedures, ensuring that the configured movement of the valve (performing a PST or moving to a set-point) is allowed. Notify proper personnel that the valve will stroke, and make sure the valve is properly isolated if required.

For the DI function, wire the DI terminals in series with a 3.5 to 40 VDC power supply as shown in Figure 36. Keep the voltage low under normal circumstances. Raise the voltage to create a tripped input state.

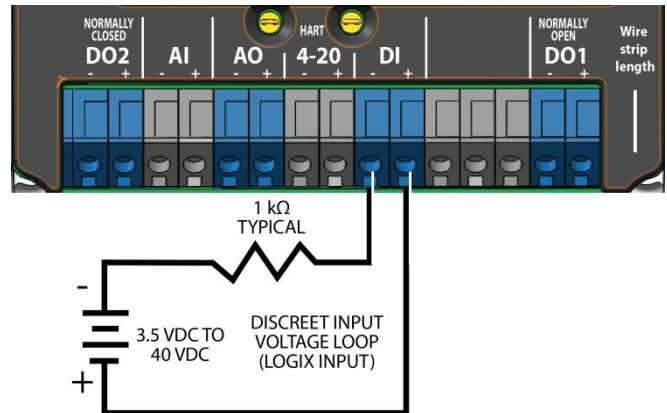

Figure 36: Discrete Input Circuit

6.3.6 Remote Mount

Use the remote mount option where excessive vibration or environmental factors prevent the placement of a positioner directly on the valve. The remote mount is an integrated part of the Logix 3820 circuitry. Wire the remote mount with Black to terminal C, White to terminal B, and Red to terminal A. For HART units, maximum cable length should be less than 30.5m (100ft). See Figure 37 for remote mount connections; these connections work for both HART and FF.

See section 16.6 Remote Mount Specifications for additional specifications.

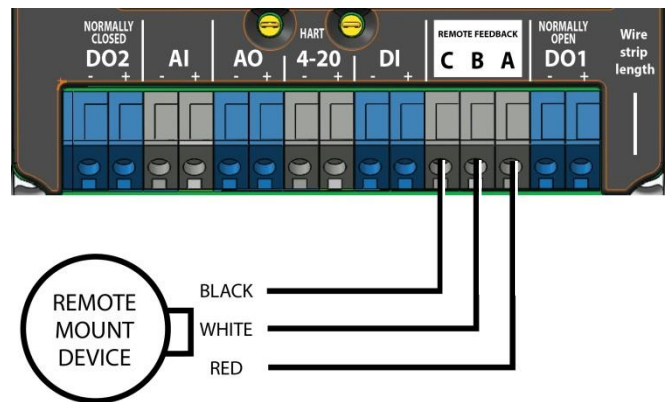

Figure 37: Remote Mount Circuit (HART)

6.3.7 I/O Circuit Specification Summary

See Table 2: Auxiliary Circuit Status for detail on the status and condition of each circuit.

Table 2: Auxiliary Circuit Status

Circuit	Condition	Status Indication
AO	Monitoring Position (typical 4-20mA)	Output (mA)
	Less than 10 V on AO terminals.	No Loop Power
AI	Monitoring AI Terminals (typical 4-20mA)	Input (mA)
	Less than 7 V on AI terminals.	No Loop Power
DO1	Active output > 2.1 mA	Closed
	Normal Operation output <1.2mA	Open
DO2	Active output <1.2mA	Open
	Normal Operation output > 2.1 mA	Closed
DI	Low (input < 2.5 VDC)	Off
	High (input > 8.0 VDC)	On

6.3.8 Connections for Intrinsically Safe Operation

See section 17, Hazardous Location Specifications for more information on intrinsically safe operation.

7 INSTALLATION – ELECTRICAL CONNECTIONS (FF)

⚠ CAUTION: Connect only wires with compatible electrical signals to the terminals. Voltages or currents outside the specified range can damage the circuit boards.

The Logix 3840 is designed to operate in a two-wire Fieldbus network. Although wiring the device to a Fieldbus network is a simple procedure, some rules exist when constructing and wiring a network. Consider the general guidelines in this section when wiring the Logix 3840 digital positioner to a Fieldbus network segment.

Figure 38 shows the terminals on the positioner unit labeled for FF protocol.

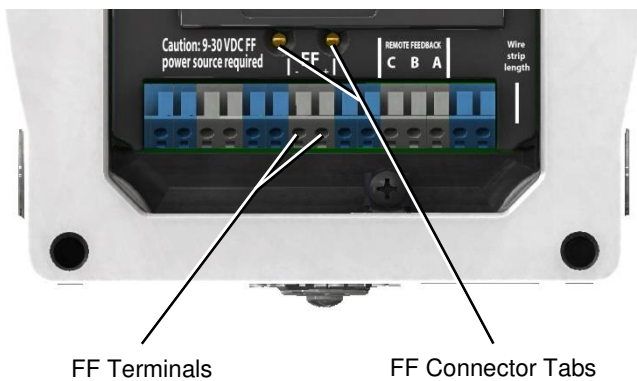

Figure 38: Terminal Diagram (FF)

7.1 Command Input (FF 9-32 VDC) Connection

Fieldbus signal communications and DC power are supplied to the Logix 3840 digital positioner using the same Fieldbus twisted pair cable. Connect the twisted pair to the input terminal labeled “FF”. The Logix 3840 has spring loaded terminal blocks that do not require tools. Depending on the source, a filter may be required. See section 13, Maintenance – Troubleshooting.

➡ NOTE: The positive and negative terminals are labeled on the cover; however, connecting a positive or negative wire to the correctly labeled terminal position is not required or important.

7.1.1 Cable Requirements

Refer to Fieldbus Foundation document AG-140, *Wiring and Installation 31.25kbits/s, Voltage Mode, Wire Medium Application Guide*, for information on wiring Fieldbus devices and building Fieldbus networks.

➡ NOTE: 24–16 AWG gauge wire sizes should be used for connection to the spring terminals. Wire sizes outside of this gauge range may not form a good connection or may cause damage to the terminals.

7.1.2 Intrinsically Safe Barriers

When selecting an intrinsically safe barrier, make sure the barrier is FF compatible and consult with a FLOWSERVE representative. Although the barrier will pass the loop current and allow normal positioner control, if not compatible, it may prevent FF communication.

7.1.3 Grounding and Conduit

The grounding terminals, located by the electrical conduit ports should be used to provide the unit with an adequate and reliable earth ground reference. Tie this ground to the same ground as the electrical conduit. Additionally, the electrical conduit should be earth grounded at both ends of its run.

➡ NOTE: The grounded screw must not be used to terminate signal shield wires. Shield wires should be terminated only at the signal source.

This product has three electrical conduit connections in thread size ½” NPT or M20. You will find an indication of the conduit thread size near the conduit connection. Conduit fittings must match equipment housing threads before installation. If threads do not match, obtain suitable adapters or contact a FLOWSERVE representative.

Figure 39 shows the conduit and grounding connections on the positioner unit labeled for FF protocol.

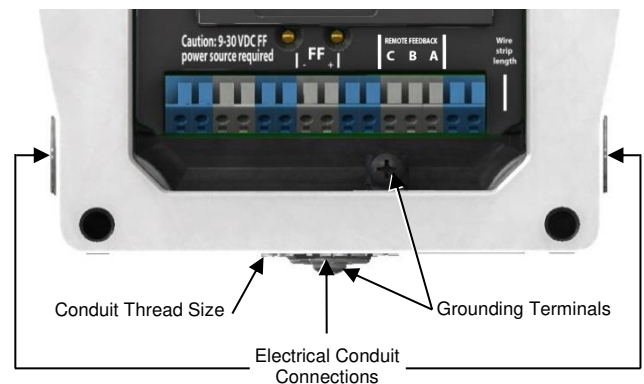

Figure 39: Conduit and Grounding (FF)

7.1.4 Electromagnetic Compatibility

The Logix 3840 digital positioner has been designed to operate correctly in electromagnetic (EM) fields found in typical industrial environments. Care should be taken to prevent the positioner from being used in environments with excessively high EM field strengths (greater than 10 V/m). Do

not use Portable EM devices such as hand-held two-way radios within 30 cm of the device.

Ensure proper wiring and shielding techniques of the control lines, and route control lines away from electromagnetic sources that may cause unwanted electrical noise. To eliminate noise use an electromagnetic line filter; contact a FLOWSERVE representative for line filter recommendations.

In the event of a severe electrostatic discharge near the positioner, the device should be inspected to ensure correct operability. It may be necessary to recalibrate the Logix 3840 positioner to restore operation.

7.1.5 Segment Compliance Voltage

Output compliance voltage refers to the voltage limit that can be provided by the FF source. A FF system consists of the FF source, wiring resistance, barrier resistance (if present), and the Logix 3840 positioner voltage. The Logix 3840 digital positioner requires that the system allows for a 9.0 VDC drop across the positioner at minimum segment voltage. The actual voltage at the terminals varies from 9.0 to 32.0 VDC depending on the FF signal and ambient temperature. See Figure 41: Compliance Voltage for more details.

Determine if the segment will support the digital positioner by performing the following calculation.

Equation 2

$$\text{Voltage} = \text{Compliance Voltage}(@18\text{mA}) - 18\text{mA} \times (R_{\text{barrier}} + R_{\text{wire}})$$

The calculated voltage must be greater than 9 VDC in order to safely support the digital positioner.

Example:

DCS Compliance Voltage = 19VDC

$R_{\text{barrier}} = 300\Omega$

$R_{\text{wire}} = 25\Omega$

Current_{max} = 18mA

Voltage = 19VDC – 0.018A × (300Ω + 25Ω) = 13.15 VDC

The voltage 13.15 VDC is greater than the required 9.0 VDC; therefore, this system will support the Logix digital positioner.

7.2 Remote Mount

Use the remote mount option where excessive vibration or environmental factors prevent the placement of a positioner directly on the valve. The remote mount is an integrated part of the Logix 3820 circuitry. Wire the remote mount with Black to terminal C, White to terminal B, and Red to terminal A. See Figure 40: Remote Mount Circuit (FF) for remote mount connections.

See section 16.6 Remote Mount Specifications for additional specifications.

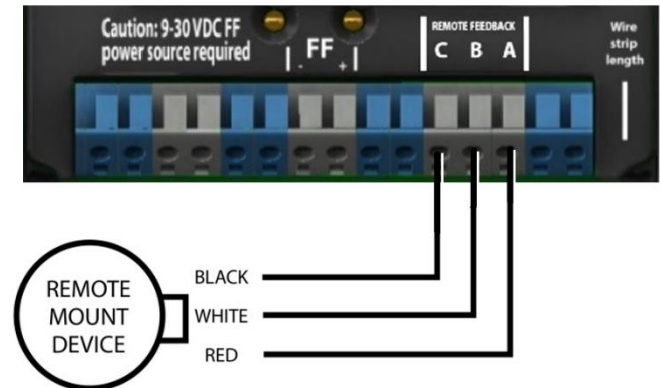

Figure 40: Remote Mount Circuit (FF)

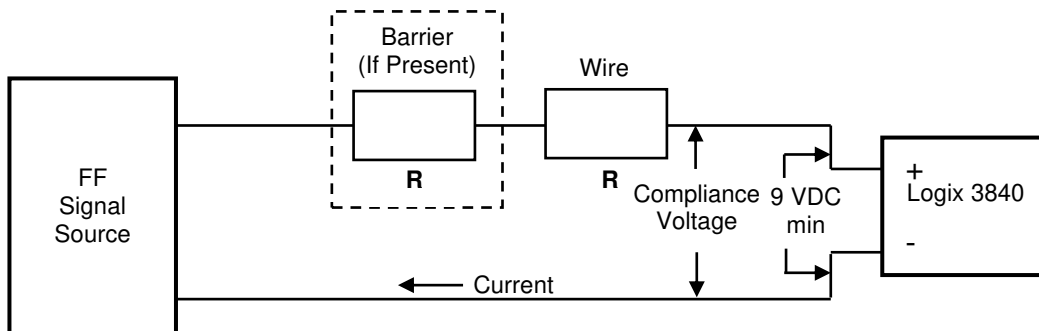

Figure 41: Compliance Voltage

8 OPERATION - HOW IT WORKS

8.1 Basic Operation (HART)

The Logix 3820 digital positioner is a two-wire 4-20 mA input digital valve positioner which uses the HART protocol to allow two-way remote communications. The positioner is completely powered by the 4-20 mA input signal. Start-up current must be at least 3.8 mA. The positioner is configurable through the local user interface, hand-held or DTM. The Logix 3800 positioner can control both double and single-acting pneumatic actuators with linear or rotary mountings.

The Logix 3800 digital positioner is an electronic and pneumatic closed-loop feedback instrument. Figure 42 shows a schematic of the Logix 3800.

8.2 Basic Operation (FF)

The Logix 3840 is a two-wire 10 V digital valve positioner which uses Foundation Fieldbus digital communication. This positioner utilizes FF communications for the command signal. The positioner is completely powered by the 9-32 V DC input signal. The command source can be accessed with a handheld communicator or other host software. The Logix 3800 positioner can control both double and single-acting pneumatic actuators with linear or rotary mountings.

The Logix 3800 digital positioner is an electronic and pneumatic closed-loop feedback instrument. Figure 42 shows a schematic of a Logix 3800.

8.3 Position Definition

Whether in Analog or Digital Source, HART or FF, the position at 0% is always defined as the valve in a closed position and 100% is always defined as the valve in an open position.

In HART Analog Source, the 4-20 mA signal is converted to a position (in percent). During loop calibration, the signals corresponding to 0% and 100% are defined.

8.4 Command Input and Final Command

The Command Input signal (in percent) passes through a characterization/limits modifier block. This function is done in software, which allows for in-the-field customer adjustment. The characterization block can apply no adjustment (Linear), one of several pre-defined characterization curve adjustments (including several Equal Percent), or a 21-point custom characterization curve adjustment. In Linear mode, the input signal is passed straight through to the control algorithm in a 1:1 transfer. With the pre-defined Equal Percent (=%) characterization curve, the input signal is mapped to a standard rangeability equal percent curve. If custom characterization is enabled, the input signal is mapped to a custom, user-defined 21-point output curve. The custom user-defined 21-point output curve is defined using a handheld or ValveSight software. Also, two user-defined features, soft limits and tight shutoff may affect the position. The actual command being used to position the stem after the evaluation of characterization curves and user limits is called the final command.

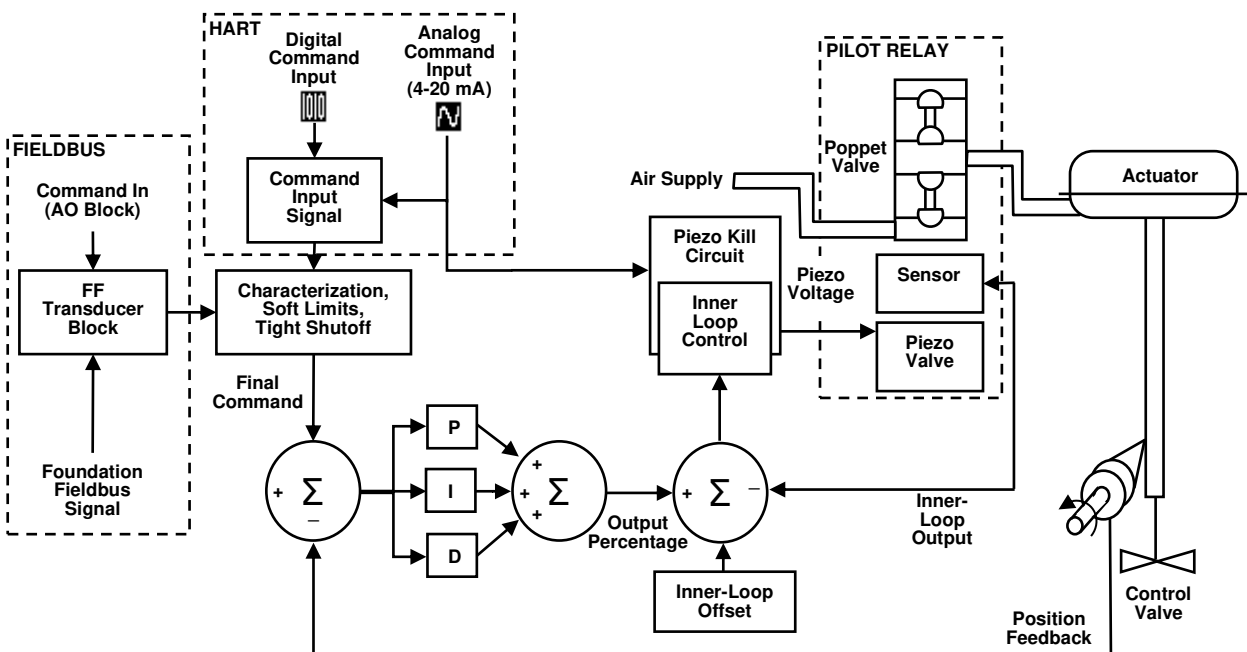

Figure 42: Principles of Operation of Logix 3800

8.5 Outer Loop

The Logix 3800 uses a two-stage, stem-positioning algorithm. The two stages consist of an inner-loop (pilot relay control) and an outer-loop (stem position control). A stem position sensor provides a measurement of the stem movement. The final command is compared against the stem position. If any deviation exists, the control algorithm sends a signal to the inner-loop control to move the relay in a direction, depending upon the deviation. The inner-loop then quickly adjusts the relay poppet valve. The actuator pressures change, and the stem begins to move. The stem movement reduces the deviation between final command and stem position. This process continues until the deviation goes to zero.

8.6 Inner Loop

The inner-loop controls the position of the relay valve using a driver module. The driver module consists of a sensor and a Piezo valve pressure modulator. The Piezo valve pressure modulator controls the air pressure under a diaphragm using a Piezo beam bender. The Piezo beam deflects in response to an applied voltage from the inner-loop electronics. As the voltage to the Piezo valve increases, the Piezo beam bends, closing off against a nozzle causing the pressure under the diaphragm to increase. As the pressure under the diaphragm increases or decreases, the poppet valve moves up or down respectively. The sensor transmits the position of the poppet valve back to the inner-loop electronics for control purposes.

8.7 Detailed Sequence of Positioner Operations

A more detailed example explains the control function. Assume the unit is configured as follows:

- The unit is in Analog command source. (if using HART)
- Custom characterization is disabled (therefore characterization is Linear).
- No soft limits enabled. No final value cutoff set.
- Valve has zero deviation with a present input signal of 50%
- Loop calibration (if using HART): 4 mA = 0% command, 20 mA = 100% command.
- Write to Final_Value to change command. (if using FF) See Logix 3800 FF Reference Guide, LGENIM3840.
- The actuator is tubed and positioner is configured air-to-open.

Given an input command of 50%, since custom characterization is disabled, the command source is passed 1:1 to the final command. Since zero deviation exists, the stem position is also at 50%. With the stem at the desired position, the relay will be at a middle position that balances the pressures above and below the piston in the actuator. This is commonly called the null position.

Assume the input signal changes from 50% to 75%. The positioner sees this as a command source of 75%. With linear

characterization, the final command becomes 75%. Deviation is the difference between final command and Stem Position: $\text{Deviation} = 75\% - 50\% = +25\%$, where 50% is the present stem position. With this positive deviation, the control algorithm sends a signal to move the poppet up from its present position. As the relay moves, the supply air is applied to the bottom of the actuator, and the air is exhausted from the top of the actuator. This new pressure differential causes the stem to start moving towards the desired position of 75%. As the stem moves, the Deviation begins to decrease. The control algorithm begins to reduce the poppet opening. This process continues until the Deviation goes to zero. At this point, the relay will be back in its null or balanced position. The desired stem position is achieved when the stem movement stops.

8.8 Inner Loop Offset

The position of the poppet at which the pressures are balanced, holding the valve position in a steady state, is called the inner loop offset. The controlling algorithm uses this value as a reference in determining the piezo voltage. This parameter is important for proper control and is optimized and set automatically during stroke calibration.

9 OPERATION – DIP SWITCH CONFIGURATION

The Logix 3800 local user interface allows the user to calibrate, configure the basic operation, and tune the response of the positioner without additional tools or configurators.

Before placing the unit in service set the DIP Switches to the desired control options. The DIP Switch settings do not take effect immediately, but are activated only by performing a Stroke calibration (pressing the “QUICK-CAL” button for 3 seconds). However, the DIP switch settings may be edited from the DTM or Handheld at any time. See Figure 43: Local User Interface.

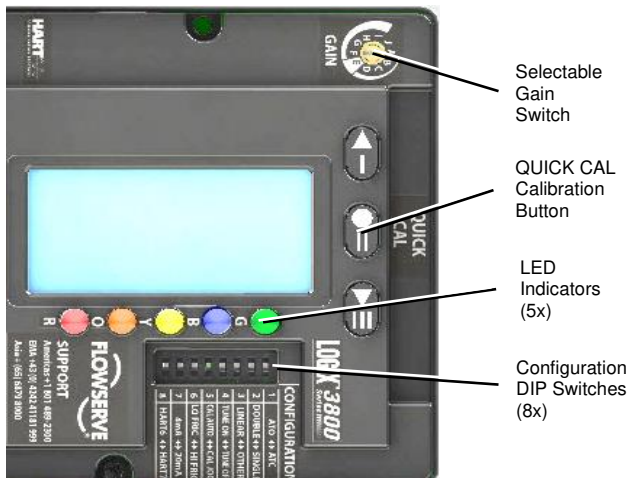

Figure 43: Local User Interface

9.1 Air Action Switch (ATO ◀▶ ATC)

The air action switch must be set to match the configuration of the valve/actuator mechanical tubing connection. The tubing determines the air action of the system.

ATO – Increasing pressure from Port A causes the valve to open.

ATC – Increasing pressure from Port A causes the valve to close.

9.2 Actuator Switch (DOUBLE ◀▶ SINGLE)

The actuator switch must be set to match the configuration of the actuator. The diagnostics and control depend on the accurate selection of this switch. .

Double – When there is pressure on both sides of the actuator Select Double.

Single – When there is pressure on only one side of the actuator select Single.

9.3 Characterization Switch (LINEAR ◀▶ OTHER)

The Characterization Switch allows a better match between the input command and the actual fluid flow through the valve. The positioner makes a correction by applying an adjustment to the input command according to a characterization curve. Usually, valves that have non-linear flow characteristics require a characterization curve to be specified.

Linear – Select Linear if the actuator position should be directly proportional to the command input signal. (For most rotary valves, this setting gives an =% Cv characteristic due to their inherent =% characteristics.)

Other – To select one of the pre-set characterization curves or a custom curve choose Other. The default is the Linear Characterization. Other custom curves such as a standard 30:1 equal percent range ability curves are available in the diagnostic tools. To select one of the other curve options, use the LCD menu, a Handheld or the ValveSight DTM. To modify the Custom curve, use the DTM.

9.4 Auto-Tune Switch (TUNE ON ◀▶ TUNE OFF)

This switch controls whether the positioner will automatically tune itself during the stroke calibration (Quick-Cal), or use preset tuning parameters. On is recommended in most cases.

On – Selecting On enables an auto tune feature that will automatically determine the positioner gain settings. Response parameters measured during the latest Quick-Cal determine the automatic tuning. The valve response is a combination of these response parameters and the current position of the Selectable GAIN Switch.

Off – Selecting Off forces the positioner to use one of the factory preset tuning sets determined by the Selectable GAIN Switch. Settings “B” through “J” are progressively higher predefined tuning sets.

Selecting “A” on the Selectable Gain Switch during a Quick-Cal allows the user to use and preserve manually adjusted gains. The calibration only sets the position limits in this case. See section 10, Operation – Calibration And Control10, for more details.

NOTE: The gain switch is LIVE meaning that regardless of the Auto-Tune selection, the gain settings can be adjusted at any time during operation by changing the selectable Gain switch position. See Figure 44: Selectable Gain Switch.

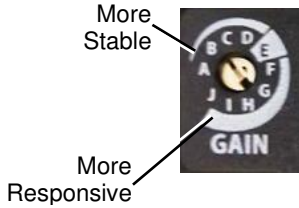

Figure 44: Selectable Gain Switch

9.5 Jog Calibration Switch (CAL AUTO ◀▶ CAL JOG)

This switch selects between Auto and Jog calibration modes.

Auto – The Auto setting works for most valves if the fully opened position of the valve has a mechanical stop. In Auto mode during a stroke calibration (Quick-Cal), the positioner will fully close the valve and register the 0% position, then fully open the valve to register the 100% position.

Jog – Use the Jog setting if the fully opened position of the valve has no hard stop and is manually set. In Jog mode during a stroke calibration (Quick-Cal), the positioner will fully close the valve and register the 0% position, then wait for the user to move the valve to the 100% open position using the Up and Down buttons. Press the ACCEPT/QUICK-CAL button to accept the 100% location.

See section 10, Operations – Calibration and Control, for more information.

9.6 Valve Stability Switch (LO FRIC ◀▶ HI FRIC)

This switch adjusts the position control algorithm of the positioner for use with low-friction control valves or high-friction automated valves.

Lo Friction – Placing the switch to Lo Friction optimizes the response for low friction, high-performance control valves. This setting provides for optimum response times when used with most low friction control valves.

Hi Friction – Placing the switch to the right optimizes the response for valves and actuators with high friction levels. This setting slightly slows the response and will normally stop limit cycling that can occur on high friction valves.

NOTE: This option is more effective on positioners with Pro diagnostic level.

9.7 Signal at Closed Switch (HART) (4mA ◀▶ 20mA)

Normally this will be set to 4 mA for an Air-To-Open actuator configuration, and 20 mA for Air-To-Close.

4 mA – Selecting 4 mA will make the valve close when the signal is low (4 mA) and open when the signal is high (20 mA).

20 mA – Selecting 20 mA will make the valve close when the signal is high (20 mA) and open when the signal is low (4 mA).

NOTE: When using an Analog Output (AO) function, the AO signal corresponds with the Signal At Closed selection. If the valve closes with a 4 mA signal, the AO will show a 4 mA signal at closed. If the valve closes with a 20 mA signal, the AO will show a 20 mA signal at closed.

9.8 HART Switch (HART) (HART 6 ◀▶ HART 7)

For HART 6 protocol, select HART6. For HART 7, select HART7.

9.9 FF WP (FOUNDATION FIELDBUS) (FF WP OFF ◀▶ ON)

To write protect variables and inputs, select ON. To leave variables writeable, select OFF.

9.10 FF SIM (FOUNDATION FIELDBUS) (FF SIM OFF ◀▶ ON)

For normal operation, select OFF. To places in simulation mode, select ON.

10 OPERATION – CALIBRATION AND CONTROL

10.1 Quick-Cal Calibration

The QUICK-CAL  button is used to initiate an automatic stroke calibration. This stroke calibration determines the closed (0%) and open (100%) positions of the valve and gathers information about the response of the valve to determine the gains. The gains are automatically set. After a stroke calibration, the positioner is ready to control.

To perform a QUICK-CAL, press and hold the QUICK-CAL  button for approximately 3 seconds.

While the automatic calibration is in progress, the LED lights will flash Y-R-Y-G (yellow-red-yellow-green) status codes indicating the calibration progress.

NOTE: *This first time the QUICK-CAL is performed, the positioner will also complete a Full Calibration. This will extend the time required for the calibration. This happens with Standard and Pro diagnostic levels.*

10.2 Full Calibration

A Full Calibration includes a stroke calibration, and also evaluates the valve friction and actuator spring characteristics. This information is used in the advanced diagnostic algorithms. When upgrading from Standard to Pro diagnostics, the calibration information and related historical data will be immediately available.

To perform a Full Calibration, press and hold the QUICK-CAL button  for approximately 6 seconds.

10.3 Jog Calibration

If the valve/actuator assembly has **no** internal mechanical stop at the fully open position, set the Jog Calibration Switch (DIP 5) to Cal Jog. In this case, press and hold the QUICK-CAL  button for approximately 3 seconds.

This process initiates the jog stroke calibration. The positioner will then close the valve and set the zero position. The zero position is automatically always set at the valve seat. At this point, the LED's will flash in a sequence of Y-R-Y-G (yellow-red-yellow-green) which indicates that the user must use the jog keys to position the valve to approximately 100% manually.

Use the  button and  button to position the valve at approximately 100% open.

Press the  ACCEPT/QUICK-CAL button to proceed.

Once complete, there are no more required user actions during calibration. The calibration is complete when the lights return to a sequence that starts with a green light.

The jog calibration process will only allow the user to set the span. If an elevated zero is needed, a handheld or ValveSight DTM are required.







10.4 Relay Balance Pressure Calibration

Relay balance pressure can be set two ways. The first calibration option uses Hot Keys, see Appendix F.

NOTE: *The valve will move to the failsafe position during the calibration procedure using hot keys.*

The second calibration option is performed manually by observing the output gauges of the positioner while the positioner is in operation.

Hot Keys Balance Pressure Calibration Option

1. Remove the plug from the relay adjustment port using a 4.0 mm hex wrench. The port will be located on the top of the relay if the positioner is mounted with the gauges on the left, or located on the bottom if the positioner is mounted with the gauges are on the right.
2. Insert a 5.5 mm hex wrench into the adjusting screw, inside the relay.
3. Initiate a relay calibration by simultaneously holding all three positioner function keys ,  and  pressed for 6 seconds. Release the buttons.
4. Press the positioner  to start the calibration process.
5. The positioner indicator lights will blink a YGBB code while the balance pressure is adjusted. This may take several minutes.
6. The positioner indicator lights will blink either GBYO "Relay Cal Adjust CW" (clockwise), or ROYB "Relay Cal Adjust CCW" (counter-clockwise) to indicate which direction the adjusting screw should be turned.
7. Using the 5.5 mm hex wrench, adjust the screw in the indicated direction in as small of an increment as possible. Watch the top and bottom pressure gauges. The target will be to make the gauges read 70% to 80% of the middle supply gauge. Press  to confirm adjustment.
8. Repeat steps 5 - 7 until the positioner indicates no further adjustment is needed by blinking GGGO "Relay Cal in Range."
9. Once the relay calibration is in range, press  to put the positioner back in operation.

Manual Balance Pressure Calibration Option

1. Remove the plug from the relay adjustment port using a 4.0 mm hex wrench. The port will be located on the top of the relay if the positioner is mounted with the gauges on the left, or located on the bottom if the positioner is mounted with the gauges on the right.
2. Insert a 5.5 mm hex wrench into the adjusting screw, inside the relay.
3. With the valve in a controlling position (between 5% and 95%), observe the top and bottom output pressure gauges. Neither of the gauges should read zero or the supply pressure shown on the middle gauge. Use the 5.5 mm hex wrench to make very small adjustments until the highest output pressure on the output gauges is 5 - 10% less than the supply pressure.
4. Adjust the screw clockwise to increase the balance pressures or counter-clockwise to decrease the balance pressure. Make an adjustment in as small of an increment as possible, and wait a minute after each adjustment to observe the pressures. The target will be to make the gauges read 70% to 80% of the middle supply gauge.

10.5 Additional Hot Key Calibrations

Hot keys can be used to initiate other function and component calibrations, such as a command input calibration, an analog input calibration, an analog output calibration and a feedback calibration. Refer to APPENDIX F – HOT KEYS for information about initiating these calibrations.

10.6 Tuning Options

Use the Selectable GAIN Switch to adjust the gain at any time during operation. This adjustment takes effect immediately. For faster response select settings above “E” (F-J). For a more stable response, select settings below “E” (B-D). See Figure 44: Selectable Gain Switch.

Quick-Cal Custom Gains – This is typically the fastest way to achieve ideal gains. Set the Auto-Tune Configuration Switch to “On” and the Selectable GAIN Switch to “E.” Then perform a Quick-Cal. During the Quick-Cal, custom tuning parameters will be determined based on measured response parameters. Fine tune the gains by adjusting the Selectable GAIN Switch. Selecting “D” “C” or “B” will progressively provide a more stable response. Selecting “F” through “J” will progressively provide a more active response. In most cases selecting “E” will give the best results and is the default setting for all actuator sizes. Raising or lowering the Selectable Gain Switch setting is a function of the positioner/valve response to the control signal, and is not actuator size dependent.

Standard Preset Gains – If standard, preset gains are desired, set the Auto-Tune Configuration Switch to Off. After performing a Quick-Cal, use the Selectable GAIN switch to the desired level (“B” – “J”). The standard, preset gain settings are not affected by Quick-Cal.

It may be necessary to set the gain switch BEFORE the Quick Cal. Very fast stroking valves may need to be at lower gains and very slow stroking valves may need to be at higher gains.

Custom Manual Gains – To set gains manually, set the selectable GAIN switch to “A.” Changing the switch from “B” to “A” will write the standard “B” settings into the “A” parameters, allowing a starting point for modification. Similarly, changing the switch from “J” to “A” will write the standard “J” settings into the “A” parameters. Custom tuning values can then be entered using the Display Menu, a Handheld or ValveSight DTM. With the Selectable GAIN Switch set to “A,” the tuning will not be modified during a Quick-Cal.

10.7 Back-up Control Mode

When enabled, backup control mode will allow the positioner to continue functioning with reduced performance if the positioner position feedback linkage is disconnected. More information on this menu feature is found in Appendix E – Status Code Descriptions. Backup control mode uses the actuator pressure(s) to estimate the valve position instead of the feedback shaft. Backup control mode requires detailed setup to insure proper operations. It will only be available under the following conditions:

- Pro-upgraded positioner
- Actuator with a spring
- Pressure and friction calibrations have been performed
- DIP switch set to “Cal-Auto” setting (Not “Jog-Cal”)
- Total rotation of feedback shaft is less than or equal to 90°

Use the following procedure to setup the backup control mode:

1. Install positioner.
2. Enable backup control mode in the menu through “Configuration>Position Feedback> Backup Control.”
3. Perform Quick-Cal.
4. Disconnect linkage and let feedback shaft spring rotate the feedback shaft to the end position.
5. Check that the Feedback Linkage Alarm (RRYG) is triggered.
6. If Feedback Linkage Alarm (RRYG) is not triggered, then remove the positioner, adjust the feedback shaft approximately 10° past the current resting point, and repeat all steps.

NOTE: *The feedback shaft has a clutch mechanism that allows for over-rotation of the shaft for easy adjustments.*

10.8 Factory Reset

To perform a factory reset, hold the QUICK-CAL  button while applying power. Factory reset causes a reset of all the internal variables to factory defaults, including calibration. The positioner must be re-calibrated after a factory reset. Restore

tag names and other user configured limits, alarm settings, and valve information.

NOTE: For HART position, a factory reset will always reset the command source to analog 4-20 mA.

CAUTION: Performing a factory reset may result in the inability to operate the valve until properly reconfigured. Notify proper personnel that the valve may stroke, and make sure the valve is properly isolated.

11 OPERATION – USER INTERFACE

11.1 LCD

The optional LCD provides a variety of useful information and functions. The Main View shows important information using icons and scrolling status lines. See Figure 45 for more detail. For display information related to fieldbus see the Logix 3800 FF Reference Guide, LGENIM3840.

Use the directional buttons to navigate from the Main View to the LCD menu. This menu provides detailed information and allows the user to perform common functions.

NOTE: The LCD backlight may change brightness during use and is normal. The backlight uses any residual power not used by other functions of the circuitry. When current supply is low (4mA) the screen will appear darker. When current supply is high (20mA) the screen will appear brighter. Also note, the LCD may not be readable at temperatures below -20°C (-4°F) and temperatures above 70°C (158°F).

The main view provides an instant display of important status parameters: Position, Final Command, Scrolling Status Message, Current Alarm Status and Status Icons.

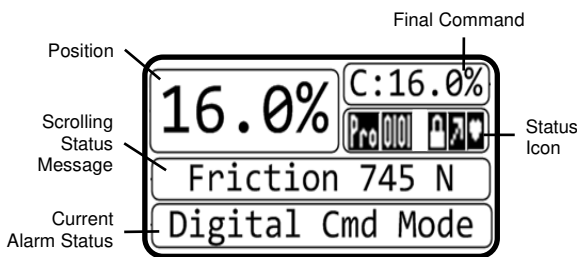

Figure 45: Display Main View

11.1.1 Position and Final Command

Shown always are the current Position and Final Command. The Final Command is the command adjusted according to a Characterization Curve, Tight Shut Off, or Soft Limits that have been applied. Final Command should match the Position.

11.1.2 Scrolling Status Messages

The Scrolling Status Message provides the following information as applicable:

Date and Time – The date and time format is adjustable.

Ambient Temperature – This is the temperature inside the positioner.

Supply Pressure – The supply pressure is available with Pro upgrade.

Friction – Calculated when the valve moves. Friction is available with the Pro upgrade.

Actuation Ratio – This is the amount of available force used to move the valve.

Air Consumption – This shows any air consumption beyond normal limits. Air Consumption is available with the Pro upgrade.

DIP Switch Override – This indicates that the Configuration (DIP) Switches do not reflect the actual configuration of the positioner. Changing a Configuration Switch after a Quick-Cal, or if the configuration is changed from the DTM will cause a Dip Switch Override. Performing a Quick-Cal will reset the configuration to what the Configuration Switches show, which may not be desirable in this case. Ensure the Configuration Switches are set properly before performing a Quick-Cal.

NOTE: The Scrolling Status Message function is disabled by default. Activate Scrolling Status Messages through the display menu.

11.1.3 Current Alarm Status

The Current Alarm Status area shows the highest priority alarm, warning, alert or status indication. This matches the code indicated by the flashing LEDs.

11.1.4 Status Icons

Status icons continuously show the state of the features and modes. See Table 3: Status Icons for more details.

Upgrade Level Icons – The upgrade levels provide increased functionality beginning at Standard and then Pro. Standard diagnostics are position-based diagnostics. Pro diagnostics include the pressure sensor functions along with full diagnostic capabilities. A Standard positioner may be upgraded to a Pro positioner in the field and while the positioner is controlling.

Command Source Icons – The positioner is in Analog Command mode if it is using the 4-20 mA signal to control the location of the valve. In Digital Command mode, a HART positioner ignores the 4-20 command and responds to the position command given through HART. Digital Command mode is normal for FF positioners. In Out Of Service mode,

the positioner is performing a calibration, signature, partial stroke test, is in a factory reset state, or another off-line mode.

Pressure Control – When the position of the valve gets very close to the commanded position, the positioning algorithm will change to pressure control. The pressures will be held constant (locked), improving the stability of the valve position. The point at which the pressure control is locked depends on the Valve Stability switch on the positioner. When the switch is set to “Lo Friction,” the locking point is self-adjusting to optimize accuracy. When the switch is set to “Hi Friction” and the deviation is smaller than +/- 1.0%, the pressure “locks.” This value can be adjusted using the Display Menu or DTM.

Communications Icons – When the positioner is sending or receiving data via the HART communication protocol, the heart icon will be displayed. During burst mode, a pulsating heart icon will be displayed. When using Foundation Fieldbus (FF) protocol, the FF icon will be displayed.

Continuous Stroke Test (CST) – For valves that are normally held at a constant position for extended periods of time, the Continuous Stroke Test can provide assurance that the valve is still responsive. When CST is on, the positioner will cause a very small amount of valve movement. From this movement, the positioner can find information about the health of the valve, actuator and positioner. This is not recommended for valves intended for high positioning accuracy or stability.

To achieve the CST function, the positioner adds a small deviation to the command. The deviation is ramped at a rate of 0.05%/second up to 5%. However, the instant the valve moves, the ramp reverses and begins to grow in the opposite direction. So, with low friction, the actual movement will be quite small. If the valve does not move by the time the deviation equals 5%, a counter will start. After 5 consecutive failed attempts to move, the CST warning will appear (YGRY) indicating that the valve is not responsive. The ramp rate, maximum limit, and frequency of the CST can be adjusted using the DTM.

Fieldbus Network Icons – The Logix 3840 can be set as a Basic device or a Link Master (LM) device. The factory default is as a Basic device. Either the Basic icon, the LM icon, or the LAS icon will be displayed always indicating the type of device the 3840 is set to. When another device or host is the acting LAS then the Logix 3800 will display either Basic or LM. When the Logix 3800 is the active LAS then the LAS icon will be displayed. For more information, see the Logix 3800 FF Reference Guide, LGENIM3840.

Table 3: Status Icons

Icon Location	Icon	Icon Meaning
Upgrade Level		Standard
		Pro upgrade
Command Source		Analog command mode
		Digital command mode
		Out of service
Pressure Control		Pressure control locked
	(blank)	Pressure control not locked
Communications		HART communication currently in progress
		HART Burst mode in progress
		FF communication currently in progress
	(blank)	No communication currently in progress
Continuous Stroke Test (CST)		CST ramping up
		CST ramping down
		CST holding steady
	(blank)	CST not activated
Fieldbus Network Modes		Basic (non LAS) (default)
		Link Master
		LAS (Link Active Scheduler)

11.2 LCD Menu Features

To enter the menu briefly press or button. A menu tree can be found in Appendix A – Lcd Menu Tree Overview. Menu features are fully described in Appendix B – Lcd Menu Tree Descriptions.

11.3 LEDs and Status Codes

LEDs give two types of status codes. The first type is a single color NAMUR status. The second type is a 4-blink status that correlates to a specific positioner error or condition. Regardless of the type of code (1 blink or 4), the LEDs always indicate a code corresponding to the highest priority alarm, warning, alert or status that is currently active.

11.3.1 Single Blink NAMUR Color Codes

If buttons on the positioner have not been pressed recently, the positioner will blink one color. This color represents one of the 5 conditions outlined in the NAMUR standard, NE-107. These are listed in Table 4: NE 107 Status Code. How these colors are assigned to specific conditions can be customized in the DTM.

Table 4: NE 107 Status Code

Single Blink Color	NE 107 Indication
	Diagnostics active – No issues
	Maintenance
	Out of specification
	Check function
	Failure

11.3.2 4-Blink Status Codes

When a button is pressed on the positioner, the color code will expand to a 4-color sequence. This corresponds to one of the specific status indications listed in Appendix D – 4-Blink Status Codes. When multiple codes are active, only the highest priority condition is represented by the blink code. To see all of the active alarms and status conditions, use a DD or DTM.

11.4 Tamper Lock

In order to prevent unintentional adjustments of the configuration, tuning, or control of the valve, the Tamper Lock feature may be used. This is set in the DTM and disables the buttons and menus except for the ability to view the status of the positioner. When locked, the positioner may be temporarily unlocked by entering a PIN. The PIN may be entered using LCD. The tamper lock feature can also be disabled in the DTM.

11.5 Write Protect (HART)

Similar to the tamper lock feature, write protect prevents unauthorized changes from across the network. Write protect restricts configuration changes and activation of diagnostics and calibrations. Write protect can be enabled and disabled by holding the hot key sequence and for 9 seconds. The blue LED will light, indicating write protect has been enabled or disabled. The LED lights will flash status code Y-G-B-B when write protect is enabled and status code R-O-Y-B when it is disabled.

NOTE: The write protect function is supported by firmware code version 1.07 and later.

11.6 Batch Schedule Task (BST)

The Batch Schedule Task (BST) function is a Pro positioner model function designed to allow a user to schedule the performance of a sequence of diagnostic tasks. The BST is valuable for tracking changes in system operation over time, which can be useful in identifying a developing or existing problem. The BST is managed through the DTM and allows the following diagnostic tasks to be scheduled in a batch task sequence:

- Signature Ramp
- Signature Step
- Partial Stroke Test
- PST History
- Sensor Calibration
- Event History
- Event Capture
- Trends
- NAMUR NE 107
- Information Annunciator
- Calibration Errors
- Tech Annunciator

11.7 Hot Keys

Hot keys are button combinations used to quickly access different features. They are available to press when the LCD screen is showing the Main view. See Table 5: Hot Keys. or for more detailed instruction, see Appendix F – Hot Keys.

Table 5: Hot Keys

	I	II	III	From Dashboard
Brief Button Press				Navigate Menu
				Continue in Menu
				Navigate Menu
				Abort Calibration
3 Sec Press				Quick-Cal*
				Command Reset (HART)
				PST
				View Code Version
				Adjust LCD Screen Contrast
				Local Valve Control
				I/O Calibrations (HART)
	6 Sec Press			
				Control with Remote Mount
				Low Level Calibration Functions
9 Sec Press				Enable and Disable Write Protect (HART)
Seq. Press				Clear PST fail error message (Hold III for 3 Sec, then briefly press II)

*A full calibration (Quick-Cal with other diagnostic evaluations) will run the first time, if a full calibration has not been completed.

11.8 Viewing Version Numbers (No LCD)

The firmware version numbers may be checked at any time except during a calibration. To see the version number, hold the and the buttons for 3 seconds. Then briefly press the button too see the major version and the button for minor version number. The codes are in a 3-blink sequence. The sequence corresponds to a number as shown in Table 6: Version Number Codes.

To exit the version viewing mode, briefly press the button. This will not alter the operation of the positioner.

Table 6: Version Number Codes

1st Blink Color	2nd Blink Color	3rd Blink Color	Version Number
G	G	G	0
G	G	B	1
G	G	Y	2
G	G	O	3
G	G	R	4
G	B	G	5
G	B	B	6
G	B	Y	7
G	B	O	8
G	B	R	9
G	Y	G	10
G	Y	B	11
G	Y	Y	12
G	Y	O	13
G	Y	R	14
G	O	G	15
G	O	B	16
G	O	Y	17
G	O	O	18
G	O	R	19
G	R	G	20
G	R	B	21
G	R	Y	22
G	R	O	23
G	R	R	24
B	G	G	25

12 OPERATION – DIAGNOSTIC LEVELS

The Logix 3800 digital positioners have two levels of diagnostics, “Standard” and “Pro.”

- “**Standard**” diagnostics provide complete safety and position-related diagnostics and data.
- “**Pro**” diagnostics enhance diagnostics with pressure data. Off-line tests are enhanced with additional pressure and force data. Powerful on-line monitoring capabilities include friction, data logging functions, back-up control mode and comprehensive system health information.

For more detail, see Table 7: Logix 3800 Features.

Table 7: Logix 3800 Features

Features	Standard	Pro
Quick Calibration Button	X	X
5-LED Indicator	X	X
8-DIP Configuration	X	X
10-Position Gain Adjustment Switch	X	X
Remote Mount Option	X	X
Terminal Voltage < 10.0 V	X	X
Alarms Stamped with Time and Date	X	X
Off-Line Diagnostics (Ramp Test, Step Test, HDRL, Partial Stroke Test)	X*	X
On-Line Data Monitor (Monitor and Save Sensor Data)	X*	X
Pressure Sensor Data (Supply, Port 1, Port 2, Control)		X
On-Line Pro Diagnostics (Force, Actuation, Pneumatic Leak, Continuous Stroke Testing, etc.)		X
Health Evaluation (Positioner, Valve, Actuator and Control)		X
Data Logging (High Speed Internal Data Capture)		X
Long-Term Trend Logging (14 parameters over 15 years)		X
Analog Output (HART)	X	X
Analog Input (HART)		X
Discrete Output 1 (Normally Open) (HART)		X
Discrete Output 2 (Normally Closed) (HART)		X
Discrete Input (HART)		X

*Excludes pressure and force data.

13 MAINTENANCE – TROUBLESHOOTING

Below are some common solutions related to commissioning.
For additional help with errors, refer to Appendix D – 4-Blink Status Codes.

13.1 Troubleshooting Guide (HART)

Table 8: Troubleshooting Guide (HART)

Failure	Probable Cause	Corrective Action
No LED is blinking.	<ol style="list-style-type: none"> 1. Current source too low. 2. The current source voltage is too low. 	<ol style="list-style-type: none"> 1. Verify current source supplies at least 3.8 mA. 2. Verify voltage source supplies at least 10VDC at terminals of device.
Erratic communications.	<ol style="list-style-type: none"> 1. Current source bandwidth is not limited to 25Hz. 2. Maximum cable length or cable impedance exceeded. 3. HART modem not receiving enough power. 4. Interference with I.S. barrier. 5. The current source is stripping (filtering) HART signal. 	<ol style="list-style-type: none"> 1. Maximum allowable current source rate of change is 924 mA per second. 2. Check cable size, length and capacitance. 3. Verify laptop battery is not low. 4. Must use HART compatible I.S. barrier. 5. Use a 250Ω resistor and a 22 μF capacitor to create a HART filter according to the following schematic.
The unit does not respond to analog commands.	<ol style="list-style-type: none"> 1. The positioner is in digital command mode. 2. An error occurred during calibration. 	<ol style="list-style-type: none"> 1. Switch to analog command mode using the one of the following procedures. <ol style="list-style-type: none"> a. Valve Sight DTM b. Handheld communicator c. Hot key – Hold for 3 seconds 2. Check Status Codes. Correct calibration error. Recalibrate.
Valve position reading is not accurate.	<ol style="list-style-type: none"> 1. Stroke not calibrated. 2. Analog input not calibrated. 3. Tight shutoff is active. 4. Custom characterization or soft stops are active. 	<ol style="list-style-type: none"> 1. Perform a Stroke calibration (Quick-Cal). 2. Perform an Analog input calibration. 2. Verify Tight Shutoff settings. 3. Verify custom characterization or soft-stop limits.
The position is driven fully open or closed and will not respond to the command.	<ol style="list-style-type: none"> 1. Bad stroke calibration. 2. The relay sensor or magnet is not connected. 3. Selected the wrong air action in the software. 4. Actuator tubing is backward. 5. The relay or piezo is malfunctioning. 6. Control parameter inner-loop offset is too high/low. 	<ol style="list-style-type: none"> 1. Perform stroke calibration (Quick-Cal) 2. Verify hardware connections. 3. Check ATO (Air-to-open) and ATC (Air-to-Close) settings. Recalibrate using Quick-Cal to apply settings. 4. Verify ATO/ATC actuator tubing. 5. Replace the relay or piezo. 6. Perform stroke calibration (Quick-Cal).

<p>Sticking or hunting operation of the positioner</p>	<ol style="list-style-type: none"> 1. Contamination of the electro-pneumatic converter. 2. Control tuning parameters not correct. 3. Packing friction is high. 4. Improper sizing of Valve/Actuator for process conditions. 	<ol style="list-style-type: none"> 1. Check air supply for proper filtering and meeting ISA specifications ISA-7.0.01. 2. Lower proportional gain settings. Use the Gain switch. 3. Change the stability DIP switch to "HI FRIC" on the local interface and recalibrate. If the problem persists, adjust pressure control window with handheld communicator or ValveSight and recalibrate. 4. Verify the Valve and Actuator are sized properly for operating conditions.
<p>LCD backlight is flickering or dim.</p>	<ol style="list-style-type: none"> 1. The backlight uses any residual power not used by other functions of the circuitry. 	<ol style="list-style-type: none"> 1. Fluctuations in the LCD backlight are normal. No action required.

13.2 Troubleshooting Guide (FF)

Table 9: Troubleshooting Guide (FF)

Failure	Probable Cause	Corrective Action
No LED is blinking	<ol style="list-style-type: none"> 1. Voltage of supply source is not high enough. 2. Current draw incorrect. 	<ol style="list-style-type: none"> 1. Verify that voltage source can supply at least 9V. 2. Verify current draw of device and that of other devices on the loop aren't pulling too much current.
Erratic communications	<ol style="list-style-type: none"> 1. Maximum cable length or cable impedance exceeded. 2. Improper grounding. 3. Interference with I.S. barrier. 4. Not connected correctly. 	<ol style="list-style-type: none"> 1. Check cable conduction size, length and capacitance. Refer to Fieldbus Foundation document AG-140. 2. Terminate and ground segment properly. 3. Must use FF-compatible I.S. barrier. 4. Check connections.
Unit does not respond to Final Value commands	<ol style="list-style-type: none"> 1. Unit is in Auto mode. 2. Error occurred during calibration. 	<ol style="list-style-type: none"> 1. Put in OOS mode. 2. Check blink codes on positioner and correct calibration error. Recalibrate.
Valve position reading is not what is expected	<ol style="list-style-type: none"> 1. Positioner tubing backwards. 2. Stroke not calibrated. 3. Tight shutoff is active. 4. Customer characterization or soft stops active. 	<ol style="list-style-type: none"> 1. Re-tube the actuator. 2. Perform RE-CAL. 3. Verify settings using PC or handheld software. 4. Verify customer characterization and soft stops.
Position is driven fully open or closed and will not respond to command	<ol style="list-style-type: none"> 1. Stroke not calibrated. 2. Inner-loop sensor not connected. 3. Wrong air action entered in software. 4. Actuator tubing backward. 5. Relay or piezo malfunctioning. 6. Control parameter inner-loop offset is too high/low. 	<ol style="list-style-type: none"> 1. Check DIP switch settings and calibrate valve stroke. 2. Verify hardware connections. 3. Check ATO (Air-to-open) and ATC (Air-to-close) settings. Recalibrate. 4. Verify ATO/ATC actuator tubing. 5. Replace relay or piezo. 6. Adjust inner-loop offset and see if proper control resumes.
Sticking or hunting operation of the positioner	<ol style="list-style-type: none"> 1. Contamination of the relay or piezo. 2. Control tuning parameters not correct. 3. Packing friction high. 4. Corroded or dirty components. 5. Improper sizing of Valve/Actuator for process conditions. 	<ol style="list-style-type: none"> 1. Check air supply for proper filtering and meeting ISA specifications ISA-7.0.01. Check the relay or piezo for contamination. 2. Adjust gain settings using local gain switch. 3. Enable the stability DIP switch on the local interface and recalibrate. If problem persists, enable pressure control with handheld communicator or SoftTools and recalibrate. 4. Disassemble and clean components or replace. 5. Verify the Valve and Actuator are sized properly for operating conditions.

14 MAINTENANCE - REPAIR

14.1 Training and Precautions

The replacement of the kits listed in section 16, Positioner Specifications, must be by a technician trained in positioner function and handling of static sensitive devices. Remove from hazardous area prior to working through any maintenance procedures.

CAUTION: Use eye protection when servicing.

CAUTION: Depressurize the positioner before servicing.

CAUTION: When touching the circuit boards, observe precautions for handling electrostatically sensitive devices.

14.2 Cleaning

With the cover in place and with cover bolts torqued to spec, the positioner may be cleaned by spraying with water. The positioner may be wiped with a soft cloth. Do not use abrasive materials, detergents, or chemicals.

14.3 Scheduled Maintenance

The supply gas filter(s) should be scheduled for regular maintenance as required to maintain supply gas quality. Any contamination found in the filter, requires visual inspection inside of the positioner for contamination. Any contamination found in the positioner, requires replacement of the positioner.

14.4 Required Tools and Equipment

The Logix 3800 digital positioner has modular components that can be replaced using the tools shown in Figure 46.

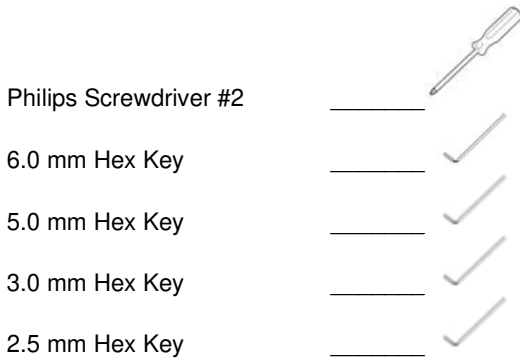

Figure 46: Tools List

14.5 Torque Specification for Screws

Table 10: Torque Specification shows the Logix 3800 torque specifications. Torque all screws to the proper specification to avoid damaging components or loosening of the screws during use.

Table 10: Torque Specification

Screw or Bolt	Type	Torque
Outer Cover – EX and SS (6 Bolts)	6 mm Hex	5.6 N-m (50 in-lb)
Outer Cover – IS (4 Bolts)	3 mm Hex	1.7 N-m (15 in-lb)
Manifold (4 Bolts)	5 mm Hex	2.8 N-m (25 in-lb)
Inner Cover (2 Screws)	Phillips	0.9 N-m (8 in-lb)
Electronic Assembly (5 Screws)	Phillips	0.9 N-m (8 in-lb)
Feedback Shaft Cover (3 screws)	Phillips	0.9 N-m (8 in-lb)

14.6 Replacing the Electronics

Refer to Figure 47: Piezo Installation and Figure 48: Replacing the Electronics.

Removal:

- 1 Make sure the valve is bypassed or in a safe condition.
- 2 Disconnect power to the positioner.
- 3 Disconnect air supply to the positioner.
- 4 Remove the inner cover by removing the two PCB cover retaining screws.
- 5 Unscrew the five electronics module retaining screws.
- 6 Gently remove the electronics by holding the terminal block and lifting the electronics from the housing.

Installation:

- 1 Verify that the 4 pressure sensor O-rings are in the electronics assembly.
- 2 Verify that the piezo O-rings are placed in the Housing.
- 3 Verify that the piezo is plugged into the bottom of the electronics assembly.
- 4 Place the electronics assembly into the housing, aligning the pressure sensor O-rings with the four holes in the housing.
- 5 Tighten the 5 electronics assembly screws down, in a star-shaped pattern, to verify even pressure for sealing the O-rings.
- 6 Torque screws to 0.9 N-m (8 in-lb).
- 7 Place inner cover over electronics assembly and tighten screws in a back and forth pattern to verify even pressure.
- 8 Torque screws to 0.9 N-m (8 in-lb).
- 9 Reconnect the valve, mounting, power, and air supply as directed by this manual.
- 10 Recalibrate as directed by this manual.

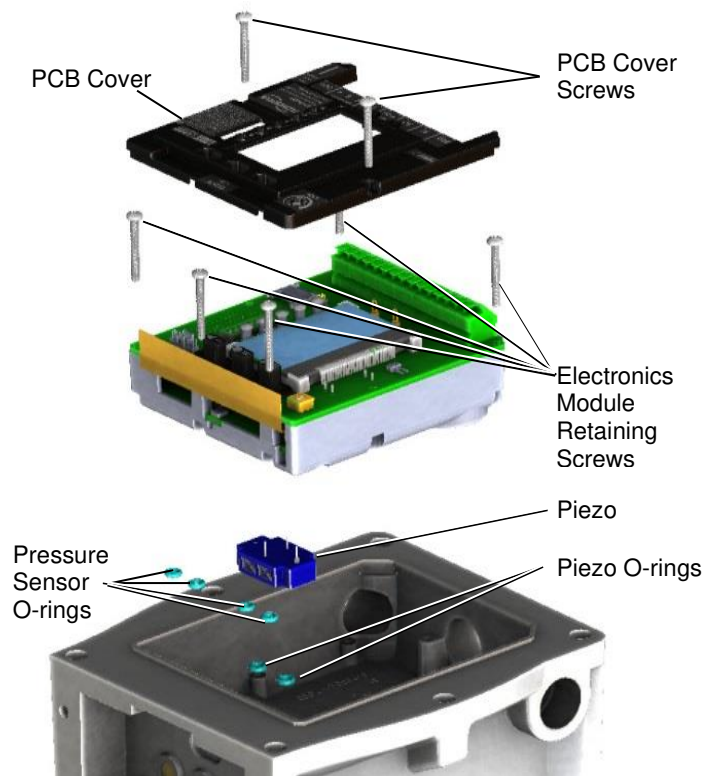

Figure 48: Replacing the Electronics

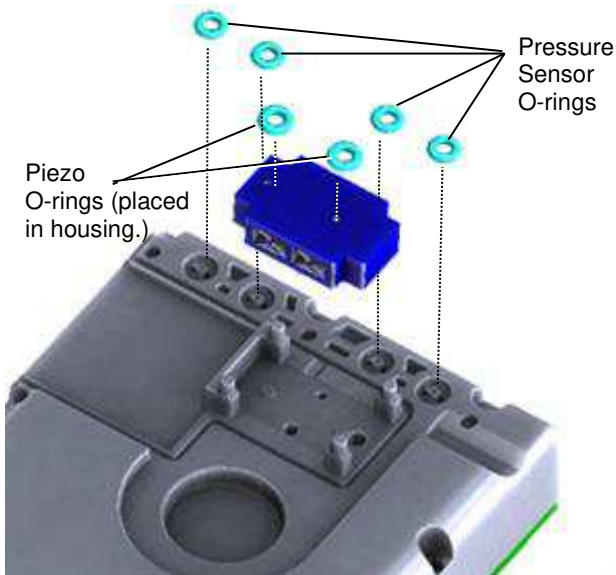

Figure 47: Piezo Installation

14.7 Replacing the Relay

Refer to Figure 49: Replacing the Relay.

Removal:

- 1 Make sure the valve is bypassed or in a safe condition.
- 2 Disconnect power and conduit to the positioner.
- 3 Disconnect air supply and actuator tubing to the positioner.
- 4 Remove the manifold bolts (using 5.0mm Hex Key).
- 5 Remove the manifold.
- 6 Discard the 5 manifold O-rings.

Installation:

- 1 Tip the housing so that the Manifold interface is facing up (so the O-rings don't fall).
- 2 Place the five new O-rings shipped in the kit in the housing.
- 3 Place the Manifold/Relay assembly onto the housing.
- 4 Tighten the 4 bolts in a star pattern to ensure even pressure.
- 5 Torque the bolts to 2.8 N-m (25 in-lb).
- 6 Readjust the positioner to the correct orientation and tighten the mounting bolts.
- 7 Reconnect power, and air supply as directed by this manual.
- 8 Recalibrate as directed by this manual.

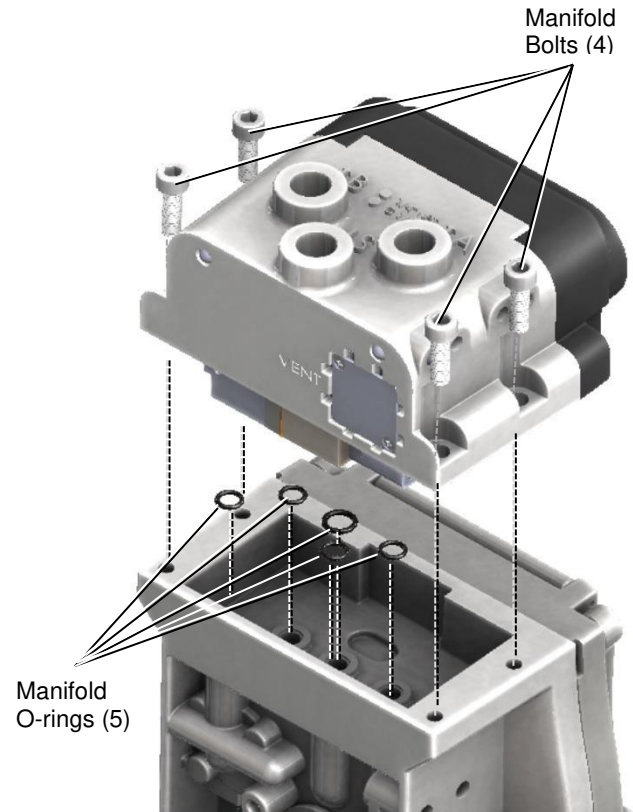

Figure 49: Replacing the Relay

14.8 Replacing the Shaft Assembly

Refer to Figure 50: Replacing the Shaft Assembly

Removal:

1. Make sure the valve is bypassed or in a safe condition.
2. Disconnect power and conduit to the positioner.
3. Disconnect air supply and actuator tubing to the positioner.
4. Unmount the positioner from actuator and disengage the shaft assembly from the follower arm assembly.
5. Place the positioner facedown so that the shaft is pointing up and use a Phillips Screwdriver #2 to remove the three feedback screws.
6. Discard the shaft assembly and screws.

Installation:

1. Apply 3M Scotch-Weld Threadlocker TL22 or Loctite 243 to the three holes on the back of the positioner housing.
2. Insert and align the new shaft assembly with the back of the housing.
3. Using a Phillips Screwdriver #2, torque the three screws to 0.9 N-m (8 in-lb).
4. Adjust the positioner to the correct mounting orientation. Connect the shaft assembly to the follower arm assembly within the working range of the shaft assembly. Finish mounting the positioner.
5. Reconnect power, and air supply as directed by this manual.
6. Perform a Stroke Calibration as directed by this manual.

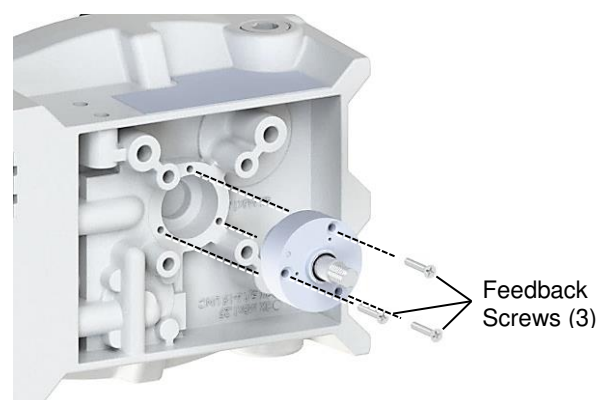

Figure 50: Replacing the Shaft Assembly

14.9 Ordering Spare Parts

For spare part kits and part numbers, see Appendix G - How To Order.

14.10 Disposal

Although the Logix 3800 is not within the scope of the Waste Electronics and Electrical Equipment (WEEE) Directive 2012/19/EU, disposal of this product should be handled by a specialized recycling facility; not by municipal waste collection services. Proper disposal is essential to the protection of the environment and community. If proper disposal is not possible, the positioner may be returned to Flowserve for disposal. Call your local sales representative for more information regarding Flowserve's disposal process and associated fee.

15 MAINTENANCE - HELP FROM FLOWSERVE

15.1 Phone Support

Over-the-phone troubleshooting is available for positioner issues. Should your positioner be experiencing problems, or if you have questions that are not answered by this manual, feel free to call your local sales representative or a Quick Response Center (QRC).

Contact your nearest FLOWSERVE sales representative.

Europe +43 (0) 4242 41181 999

North America +1 801 489-2300

Asia + (65) 6879 8900

digitalproductstac@flowserve.com

See the back cover of this manual for additional contact details.

15.2 Returning the Logix 3800 Positioner for Service

Returning the unit is an option if troubleshooting is unable to solve the problem. Please follow the steps below.

1. Request a Return Goods Authorization (RGA) form. The form should arrive in an email.
2. Remove all fittings, brackets, filters, feedback arms, etc. from the unit before packaging.
3. When operating the unit with a gas other than clean air requires the related MSDS with the unit.
4. Complete the RGA form. Write any particular issues with the positioner you would like us to evaluate. Please include the customer name and contact information.
5. When packaging, please secure the unit in a method that will ensure it will reach our facility undamaged (the weight of positioners will often settle through packing peanuts and pop large air pockets).
6. Please insert a copy of the completed RGA form inside the package and write the RGA number on the outside of the package. Send the unit to the address at the bottom of the form.

If the cause of the unit failure is found to be a manufacturing defect and the unit is within the warranty period it will be repaired free of charge. There is a fee for the evaluation in the event there is no problem found with the unit, and the unit is still under warranty. A fee will be charged for the evaluation if the warranty does not cover the cause of the unit failure. A quote will be provided showing the cost of the repair. Waiving of the fee requires the customer to purchase a new positioner.

16 POSITIONER SPECIFICATIONS

16.1 Input Signal

Table 11: Input Signal (HART)

Power Supply	Two-wire, 4-20 mA 10.0 VDC plus line losses
Input Signal Range	4 - 20 mA
Compliance Voltage	10 to 32 VDC @ 20 mA
Effective Resistance	500 Ω @ 20 mA Typical
Minimum Required Operating Current	4.0 mA
Maximum Shutdown Current	3.6 mA
Power Interruption Time Limit	After applying power for at least 1 minute, a 40 ms power interruption will not cause the positioner to reset.
Power-up time	Time from the application of power to begin controlling valve < 1.0 second.
Communications	HART protocol (Logix 382X- only)
Wire	Spring Terminal 24-16 AWG
Cable	Refer to the HART Field Communications Protocol Application Guide, HART HCF LIT

Table 12: Input Signal (FF)

Power Supply	Two-wire, 9 to 32 V DC FF compatible
Input Voltage Limits	36.0 VDC 9 to 32 V DC for general use and flameproof applications 9 to 24 V DC for Intrinsically safe applications 9 to 17.5 VDC for Intrinsically safe applications per FISCO requirements
Operating Current	18.5 mA
IS	Fisco compliant
Communications	FF Protocol ITK 6.1.2
Wire	Spring Terminal 24-16 AWG
Cable	Refer to Fieldbus Foundation AG-140, Wiring and Installation 31.25kbits/s, Voltage Mode, Wire Medium Application Guide

16.2 Pneumatic Output

Table 13: Pneumatic Output

Output Pressure Range	0 to 100% of air supply pressure.
Output Air Capacity	14.3 Nm ³ /h @ 1.5 bar (8.44 SCFM @ 22 PSI) 30.6 Nm ³ /h* @ 4.1 bar (17.5 SCFM* @ 60 PSI Cv 0.47) <small>*Port screen filters may reduce the output air capacity to 22.4 Nm³/h @ 4.1 bar (12.8 SCFM @ 60 PSI Cv 0.35). Removal of the filters may be required to obtain maximum air capacity.</small>
Primary Output Ports (Pressurized port is in energized state. Port is exhausted upon loss of power.)	Port A

16.3 Air Supply

Table 14: Air Supply

Minimum Input Pressure	1.5 Bar (22 PSI)
Maximum Input Pressure	10.3 Bar (150 PSI)
Air Supply Quality	The air supply must be free from moisture, oil, and dust by conforming to the ISA 7.0.01 standard. (A dew point at least 18° F below ambient temperature, particle size below five microns, and oil content not to exceed one part per million).
Operating Humidity	0 - 100% non-condensing
Acceptable Supply Gasses	Air, sweet natural gas, nitrogen, and CO ₂ are acceptable supply gasses. Sour natural gas is not acceptable. For Type nA and Type tb installation, only connect air or inert gas to the air supply inlet.
Air Consumption Standard Relay	0.297 Nm ³ /h @ 1.5 bar (0.175 SCFM @ 22 PSI) 0.51 Nm ³ /h @ 4.1 bar (0.300 SCFM @ 60 PSI Cv 0.008)
Air Consumption Low Bleed Relay	0.075 SCFM @ 60 PSI Cv 0.002

16.4 Analog Output (HART)

Table 15: 4 to 20 mA Analog Output Specification

Power Supply Range	10.0 to 40 VDC, (24 VDC Typical)
Current Signal Output	4 to 20 mA
Linearity	1.25% F.S.
Repeatability	0.25% F.S.
Hysteresis	1.0% F.S.
Operating Temperature	-55 to 85°C (-67 to 185°F)

16.5 Stroke Output

Table 16: Stroke Output

Feedback shaft Rotation	Min 15°, Max 110° (with spring bias) Max 180° (without spring bias) 60° recommended for linear applications.
-------------------------	--

16.6 Remote Mount Specifications

Table 17: Remote Mount Module Specifications

Remote Mount Device	Use only with Logix™ Remote-Mount Option device.
Max Cable and Tube Distance	30.5 m (100 ft) for ½" dia. tubing 9.1 m (30 ft) for ¼" dia. tubing
Operating Temperature	-55 to 124°C (-67 to 255°F)

NOTE: When using tubing near maximum lengths the positioner performance may be degraded.

16.7 Positioner Performance Characteristics

Table 18: Performance Characteristics

Better than or equal to the following values on a 25 square inch Mark I actuator.	
Resolution	≤ 0.25%
Linearity	+/-0.8%
Repeatability	≤ 0.05%
Hysteresis	≤ 1.0%
Deadband	≤ 0.1%
Sensitivity	≤ 0.25%
Stability	≤ 0.4%
Long term drift	≤ 0.5%
Supply Pressure Effect	≤ 0.2% per 10 psi (0.69 bar)

NOTE: Performance tested according to ISA 75.13.

16.8 Temperature

Table 19: Temperature

Operating Temperature Range	-55 to 85°C (-67 to 185°F)
Transport and Storage Range	-55 to 85°C (-67 to 185°F)

NOTE: Reduced performance possible at low and high temperatures. LCD may not be readable at temperatures below -20°C (-4°F) and temperatures above 70°C (158°F).

16.9 Physical Specifications

Table 20: Physical Specifications

Housing Material	Cast, powder-painted Copper-free aluminum (EN AC-43400/EN AC-ALSi10Mg(Fe)) Cast, stainless steel (A-743-CN7M (ALLOY 20))
Soft Goods	Fluorosilicone / Fluorocarbon / Buna-N
Weight of Base Positioner Without Accessories	4 kg (8.8 lbs.) – Aluminum 8 kg (17.6 lbs.) – Stainless Steel (Alloy 20)

16.10 ValveSight DTM Software Specifications

Table 21: ValveSight DTM Software Specifications

Computer	Minimum Pentium processor running Windows 2000, XP, Server 2003, Server 2003 R2, Server 2008 (32-bit & 64-bit Versions), Server 2008 R2 (32-bit & 64-bit Versions), and 7 (32-bit & 64-bit Versions). Memory: >64MB Available HARD Disk Space : >64MB
Ports	One minimum available with eight maximum possible. (Can also communicate via serial, and USB connections)
HART Filter	Often required in conjunction with some DCS hardware.
FIELDBUS	Fieldbus Communications manager and/or LAS

16.11 Positioner Dimensions - Explosion Proof Housing

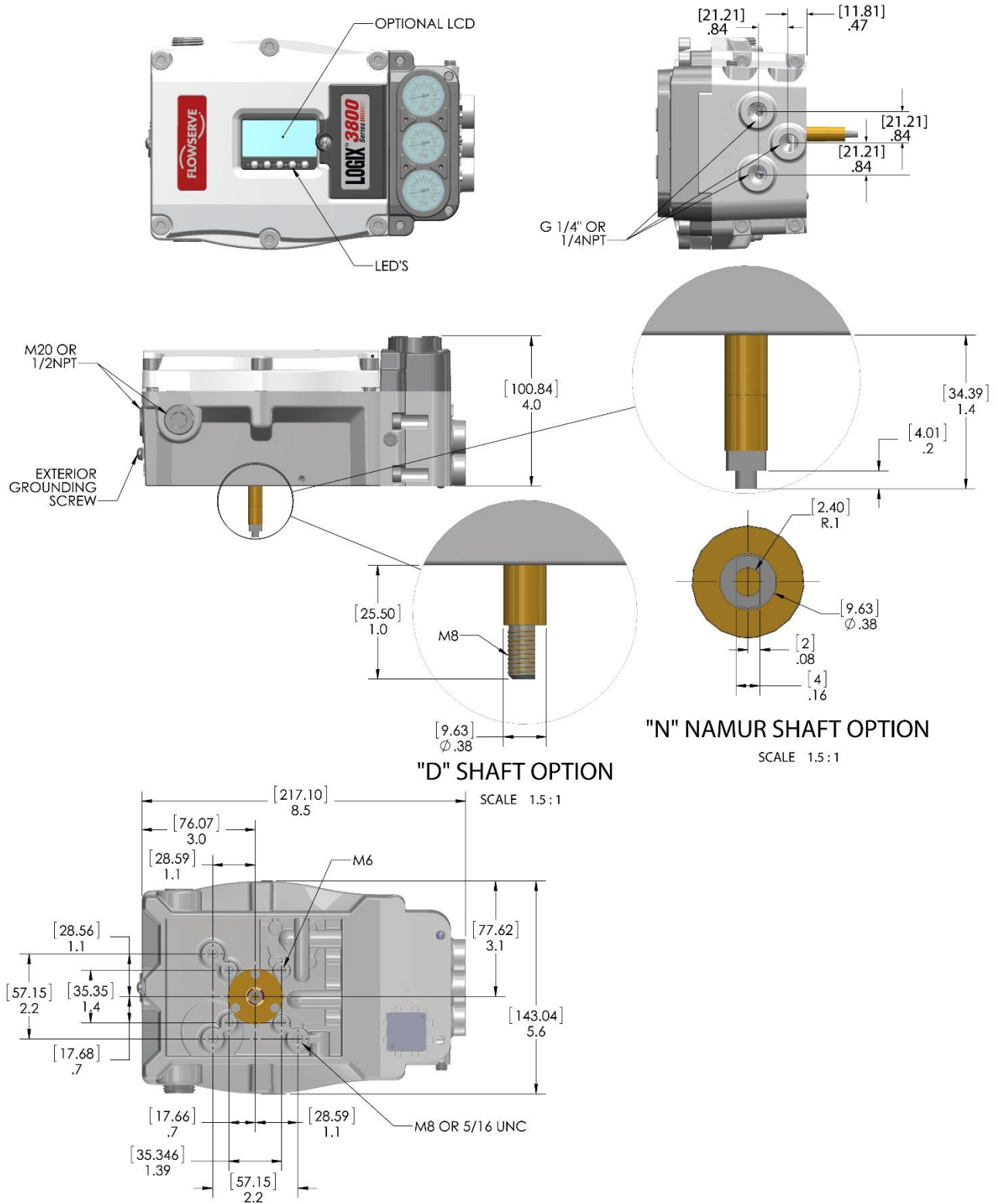

Figure 51: Positioner Physical Dimensions (EX and SS)

17 Hazardous Location Specifications

17.1 Hazardous Location Information

Table 22: Logix 3800 Ex Hazardous Location Information

	Certification Code	Area	Protection Method	Markings	Temperature Code	Enclosure Ratings		
	34	US / CANADA	Explosion Proof	XP - Class I, Div 1, Groups B,C,D, T6...T4	T4 = -50C to +85C	Type 4X, IP66		
				US - Class I, Zone 1, AEx db IIC T6...T4 Gb	T5 = -50C to +55C			
				CANADA- Ex db IIC T6...T4 Gb	T6 = -50C to +45C			
			Intrinsically Safe	IS - Class I,II,III, Div 1, Groups A-G T6...T4	T4 = -55C to +85C			
				US -Class I, Zone 0, AEx ia IIC T6...T4 Ga			T5 = -55C to +55C	
				Canada - Ex ia IIC T6...T4 Ga			T6 = -55C to +45C	
				US -Class I, Zone 1, AEx ib IIC T6...T4 Gb				
				Canada - Ex ib IIC T6...T4 Gb				
				US -Class I, Zone 2, AEx ic IIC T6...T4 Gc				
			Non Incendive/ Non - Sparking	NI - Class I, Div 2, Groups A,B,C,D T6...T4	T4 = -55C to +85C			
				US - Class I, Zone 2, AEx nA IIC T6...T4 Gc			T5 = -55C to +55C	
				Canada - Ex nA IIC T6...T4 Gc			T6 = -55C to +45C	
US - Class I, Zone 2, AEx ec IIC T6...T4 Gc								
Dust	Class II, III, Div 1, Groups E,F,G T6...T4	T4 (- 55°C <tamb< +85°C)						
	US - Zone 21, AEx tb IIIC T105°C Db	T5 (- 55°C <tamb< +60°C)						
	Ex ia IIIC T200156° Da Ta = -55C to +85C	T6 (- 55°C <tamb< +45°C)						
			Canada - Ex tb IIC T105°C Db	Tamb = -50C to +85C				
	45	US / CANADA	US Explosion Proof	XP - Class I, Div 1, Groups A,B,C,D, T6...T4	T4 = -50C to +85C	Type 4X, IP66		
			Canada Explosion Proof	XP - Class I, Div 1, Groups B,C,D, T6...T4			T5 = -50C to +55C	
			Dust	Class II, III, Div 1, Groups E,F,G T6...T4			T6 = -50C to +45C	
	28	ATEX	Explosion Proof	II 2 G - Ex db IIC T6...T4 Gb	T4 = -55C to +85C	Type 4X, IP66		
				Dust			II 2 D - Ex tb IIIC T105°C Db Ta = -55C to +85C	
			Intrinsically Safe	II 1 G - Ex ia IIC T6...T4 Ga			T5 = -55C to +55C	
				II 1 G - Ex ib IIC T6...T4 Gb				T6 = -55C to +45C
				II 3 G - Ex ic IIC T6...T4 Gc				
			Non -Sparking	II 3 G - Ex nA IIC T6...T4 Gc				
				II 3 G - Ex ec IIC T6...T4 Gc				
				28			IECEX	Explosion Proof
Dust	Ex tb IIIC T105°C Db Ta = -55C to +85C							
	Ex ia IIIC T200 156° Da Ta = -55C to +85C							
Intrinsically Safe	Ex ia IIC T6...T4 Ga	T5 = -55C to +55C						
	Ex ib IIC T6...T4 Gb		T6 = -55C to +45C					
Non -Sparking	Ex ic IIC T6...T4 Gc							
		Ex nA IIC T6...T4 Gc						
			Ex ec IIC T6...T4 Gc					
	28	KOSHA	Explosion Proof	Ex db IIC T6...T4 Gb	T4 = -50C to +85C	Type 4X, IP66		
			Intrinsically Safe	Ex ia IIC T6...T4 Ga			T5 = -50C to +55C	
	28	NEPSI	Explosion Proof	Ex db IIC T6...T4 Gb	T4 = -50C to +85C	Type 4X, IP66		
			Intrinsically Safe	Ex ia IIC T6...T4 Ga			T5 = -50C to +55C	
				Ex ic IIC T6...T4 Gc	T6 = -50C to +45C			

	Certification Code	Area	Protection Method	Markings	Temperature Code	Enclosure Ratings
CCOE / PESO India		CCOE	Non -Sparking	Ex nA IIC T6...T4 Gc	T4 = -50C to +85C T5 = -50C to +55C T6 = -50C to +45C	Type 4X, IP66
			Explosion Proof	Ex db IIC T6...T4 Gb		
			Intrinsically Safe	Ex ia IIC T6...T4 Ga Ex ic IIC T6...T4 Gc		
	06	INMETRO	Explosion Proof	Ex db IIC T6...T4 Gb	T4 = -55C to +85C T5 = -55C to +55C T6 = -55C to +45C	Type 4X, IP66
			Dust	Ex tb IIIC T105°C Db Ta = -55C to +85C Ex ia IIIC T105C Da Ta = -55C to +85C		
			Intrinsically Safe	Ex ia IIC T6...T4 Ga Ex ib IIC T6...T4 Gb Ex ic IIC T6...T4 Gc		
			Non -Sparking	Ex nA IIC T6...T4 Gc		
	44	TR CU	Explosion Proof	Ex db IIC T6...T4 Gb	T4 = -55C to +85C T5 = -55C to +55C T6 = -55C to +45C	Type 4X, IP66
			Dust	Ex tb IIIC T105°C Db Ta = -55C to +85C Ex ia IIIC T105C Da Ta = -55C to +85C		
			Intrinsically Safe	Ex ia IIC T6...T4 Ga Ex ib IIC T6...T4 Gb Ex ic IIC T6...T4 Gc		
			Non -Sparking	Ex nA IIC T6...T4 Gc		
 	47	IECEX	Explosion Proof	Ex d IIC T6...T4 Gb	T4 = -55C to +85C T5 = -55C to +55C T6 = -55C to +45C	Type 4X, IP66
			Dust	Ex tD A21 T105°C Db Ex iaD 20 T105°C Da		
			Intrinsically Safe	Ex ia IIC T6...T4 Gb Ex ib IIC T6...T4 Gb Ex ic IIC T6...T4 Gc		
			Non -Sparking	Ex nA IIC T6...T4 Gc		

Table 23: Logix 3800 IS Hazardous Location Information

	Certification Code	Area	Protection Method	Markings	Temperature Code	Enclosure Ratings
	37	US / CANADA	Intrinsically Safe	US -Class I, Zone 0, AEx ia IIC T6...T4 Ga	T4 = -55C to +85C T5 = -55C to +55C T6 = -55C to +45C	Type 4X, IP66
				Canada - Ex ia IIC T6...T4 Ga		
				US -Class I, Zone 0, AEx ib IIC T6...T4 Gb		
			Canada - Ex ib IIC T6...T4 Gb			
			US -Class I, Zone 0, AEx ic IIC T6...T4 Gc			
			Canada - Ex ic IIC T6...T4 Gc			
		Non Incendive	NI - Class I, Div 2, Groups A,B,C,D T6...T4			
			US - Class I, Zone 0, AEx nA IIC T6...T4 Gc			
			Canada - Ex nA IIC T6...T4 Gc			
		Dust	Class II, III, Div 1, Groups E,F,G T6...T4	T4 = -50C to +85C T5 = -50C to +55C T6 = -50C to +45C		
			US - Zone 21, AEx tb IIIC T105°C Db	Tamb = -50C to +85C		
			Ex ia IIIC 156° Da Ta = -55C to +85C Canada - Ex tb IIC T105°C Db			
	ATEX	Dust	II 2 D - Ex tb IIIC T105°C Db Ta = -55C to +85C	Ta = -55C to +85C	Type 4X, IP66	
			II 1 D - Ex ia IIIC T200 156° Da Ta = -55C to +85C			
			II 1 G - Ex ia IIC T6...T4 Ga			
Intrinsically Safe	II 1 G - Ex ib IIC T6...T4 Gb	T4 = -55C to +85C T5 = -55C to +55C T6 = -55C to +45C				
	II 3 G - Ex ic IIC T6...T4 Gc					
Nonsparking	II 3 G - Ex nA IIC T6...T4 Gc					
	IECEX	Dust	Ex tb IIIC T105°C Db Ta = -55C to +85C	T4 = -55C to +85C T5 = -55C to +55C T6 = -55C to +45C	Type 4X, IP66	
			Ex ia IIIC T200 156° Da Ta = -55C to +85C			
		Intrinsically Safe	Ex ia IIC T6...T4 Ga			
			Ex ib IIC T6...T4 Gb			
Type 'n'	Ex ic IIC T6...T4 Gc					
	KOSHA	Intrinsically Safe	Ex ia IIC T6...T4 Ga	T4 = -50C to +85C T5 = -50C to +55C T6 = -50C to +45C	Type 4X, IP66	
				CCOE		Intrinsically Safe
Ex ic IIC T6...T4 Gc						
	06	INMETRO	Intrinsically Safe	Ex ia IIC T6...T4 Ga	T4 = -50C to +85C T5 = -50C to +55C T6 = -50C to +45C	Type 4X, IP66
				Ex ib IIC T6...T4 Gb		
			Ex ic IIC T6...T4 Gc			
Type 'n'	Ex nA IIC T6...T4 Gc					
Dust	II 2 D - Ex tb IIIC T105°C Db Ta = -55C to +85C	Ta = -55C to +85C				
	II 1 D - Ex ia IIIC T105°C Da Ta = -55C to +85C					
	44	TR CU	Dust	Ex tb IIIC T105°C Db Ta = -55C to +85C	T4 = -55C to +85C T5 = -55C to +55C T6 = -55C to +45C	Type 4X, IP66
				Ex ia IIIC T105°C Da Ta = -55C to +85C		
			Intrinsically Safe	Ex ia IIC T6...T4 Ga		
				Ex ib IIC T6...T4 Gb		
Type 'n'	Ex ic IIC T6...T4 Gc					
				Ex nA IIC T6...T4 Gc		

17

17.2 Entity and FISCO Compliant Parameters

Table 24: Entity Parameters Models 382X

Logix 3800 Entity Parameters					
Field Connections	4-20	Optional DO1 & DO2	Optional AI	Optional AO	Optional DI
UI (Vmax) =	30 VDC	30 VDC	30 VDC	30 VDC	30 VDC
li(I _{max}) =	380 mA	500mA	250 mA	250 mA	380 mA
Pi(P _{max}) =	5.32W	2.5W	3.8W	2.0W	5.32W
Li =	0	0	0	0	0
Ci =	0	23nF	0	0	0

Table 25: Foundation Fieldbus FISCO Compliant Models 384X

Logix 3800 FISCO Field Device	
FISCO Compliant	FF 9-30V
UI (Vmax) =	30 VDC
li(I _{max}) =	380 mA
Pi(P _{max}) =	5.32W
Li =	0
Ci =	0

See Appendix G - How To Order for complete model listing.

17.3 Warnings and Special Conditions for Safe Use

Warning!

- Substitution of components may Impair Intrinsic safety.
- DO NOT OPEN, MAINTAIN OR SERVICE IN AN AREA WHERE AN EXPLOSIVE ATMOSPHERE MAY BE PRESENT

Special Conditions for Safe Use:

- For Intrinsically Safe installations the positioner must be connected to suitably rated intrinsically safe equipment, and must be installed in accordance with applicable intrinsically safe installation standards.
- Use appropriately rated cable insulation at higher temperatures.
- Contact Flowserve for Flame Path information.
- The Model 38X0 and 38X1 Positioner enclosures contain aluminum and are considered to present a potential risk of ignition by impact or friction. Care must be taken into account during installation and use to prevent impact or friction. Clean only with damp cloth.
- Provisions shall be made externally to provide transient overvoltage protection to a level not to exceed 140% of the peak rated input voltage.
- Using the box provided on the nameplate, the User shall permanently mark the type of protection chosen for the specific installation. Once the type of protection has been marked it shall not be changed.
- Potential electrostatic charging hazard. Clean only with a damp cloth.
- Discontinue use of equipment if the fasteners securing the enclosure cover or the cover window are damaged. Contact Flowserve for repair.
- Cable, cable guard, or conductors in conduit should have insulation rated for at least 18K above the maximum expected ambient temperature of the environment or installation.

AVERTISSEMENT:

- La substitution de composants peut compromettre la sécurité intrinsèque.
- NE PAS OVRIR, MAINTENIR OU SERVIR DANS UNE ZONE OU UNE ATMOSPHERE EXPLOSIVE PEUT ÊTRE PRÉSENTE

Assessed to the following ATEX standards:

EN 60079-0:2012+A11:2013, EN 60079-1:2014, EN 60079-11:2012, EN 60079-31:2014, EN 60529:1991+A1:2000+A2:2013
EN 60079-0:2012+A11:2013, EN 60079-11:2012, EN 60079-15:2010 and EN 60529:1991+A1:2000+A2:2013

Assessed to the following IECEx standards:

IEC 60079-0:2011, IEC 60079-1:2014-06, IEC 60079-11:2011, IEC 60079-15:2010, IEC 60079-31:2013

Assessed to the following US standards:

FM Class 3600:2011, FM Class 3610:2015, FM Class 3611:2016, FM Class 3615:2006, FM Class 3616:2011, FM Class 3810:2005, ANSI/ISA-12.12.01-2016, ANSI/ISA 60079-0:2013, ANSI/UL 60079-1:2015, ANSI/ISA 60079-11:2014, ANSI/ISA 60079-15:2012, ANSI/ISA-60079-31: 2015, ANSI/ISA 61010-1:2004, ANSI/UL 50E:2015, ANSI/IEC 60529:2014

Assessed to the following CSA standards:

CSA C22.2 NO. 0.4-04:2017, CSA C22.2 NO. 0.5-16:2016, CSA C22.2 No. 25-1966:1966 (Reaffirmed 2014), CSA C22.2 No.30-M1986:1986 (Reaffirmed 2016), CSA C22.2 No.94.2:2015, CSA C22.2 No. 213-16:2016, CSA C22.2 No. 1010.1:2004, CAN/CSA C22.2 No. 60079-0:2015, CAN/CSA C22.2 No. 60079-1:2016, CAN/CSAC22.2 No. 60079-11:2014, CAN/CSAC22.2 No. 60079-15:2016, CAN/CSA-C22.2 No. 60079-31:2015, CSA C22.2. 60529:2005 (Reaffirmed 2015)

Assessed to the following EMC standards (EMC Directive 2014/30/EU/EC):

EN 61000-3-2 IEC 61000-4-3 IEC 61000-4-6
EN 61000-3-3 IEC 61000-4-4 IEC 61000-4-8
IEC 61000-4-2 IEC 61000-4-5 IEC 61000-4-11
EN 61326-1:2006 – for use in industrial environments EN 61326-1:2013
EN 55011 Class A Group 1
Namur NE 21 Version: 22.08.2007

17.5 Control Drawing – ATEX / IECEx Connection Diagram

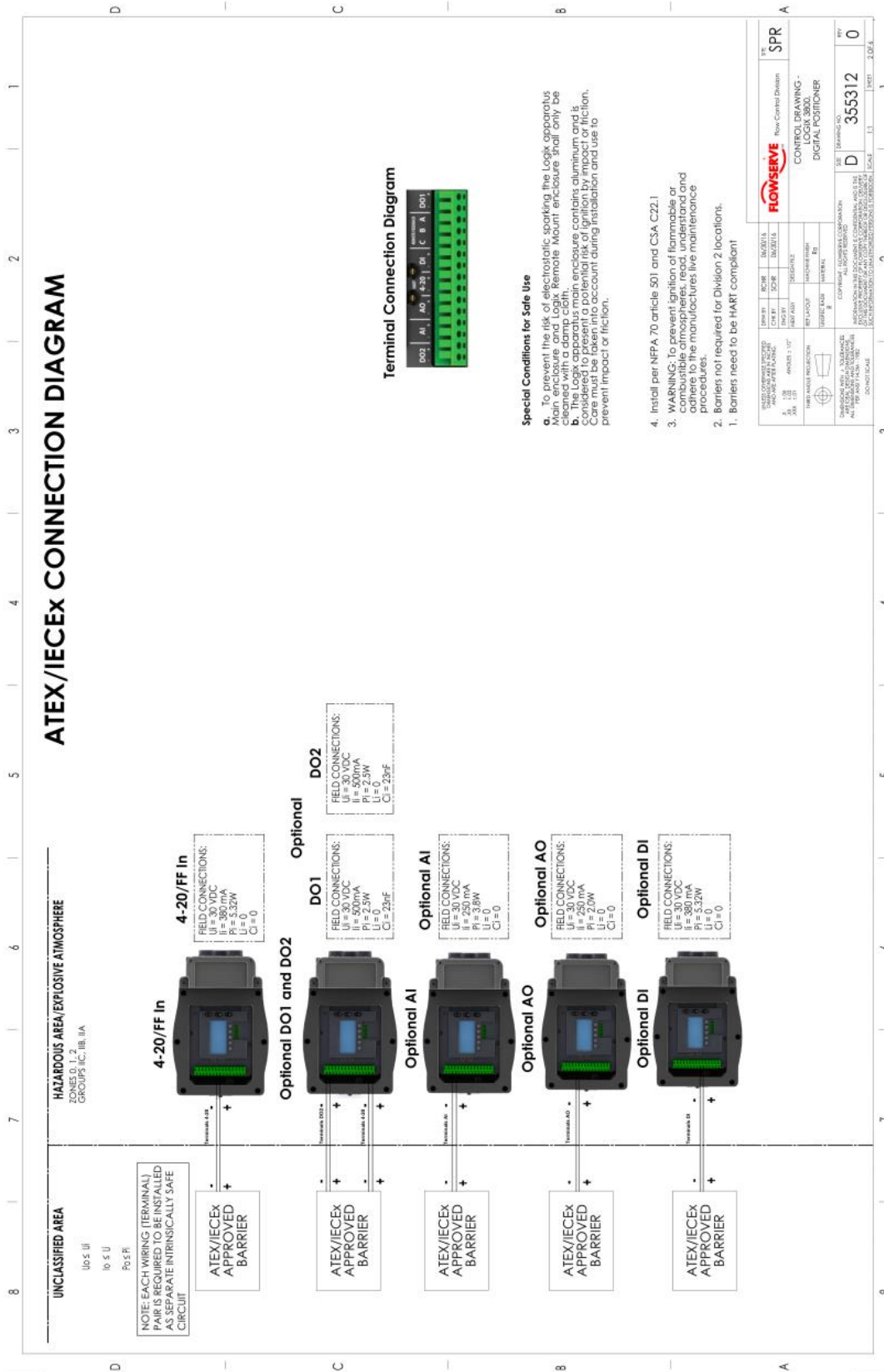

DESIGNED BY	DATE	SCALE	REV
CHK'D BY	DATE		
APP'D BY	DATE		
PROJECT	DESCRIPTION		
REV	DESCRIPTION	DATE	BY
0	355312		

FLOWERVE Row Control Division
 CONTROL DRAWING -
 LOGIX 3800
 DIGITAL POSITIONER

17.7 Control Drawing – FISCO Installation US and Canada

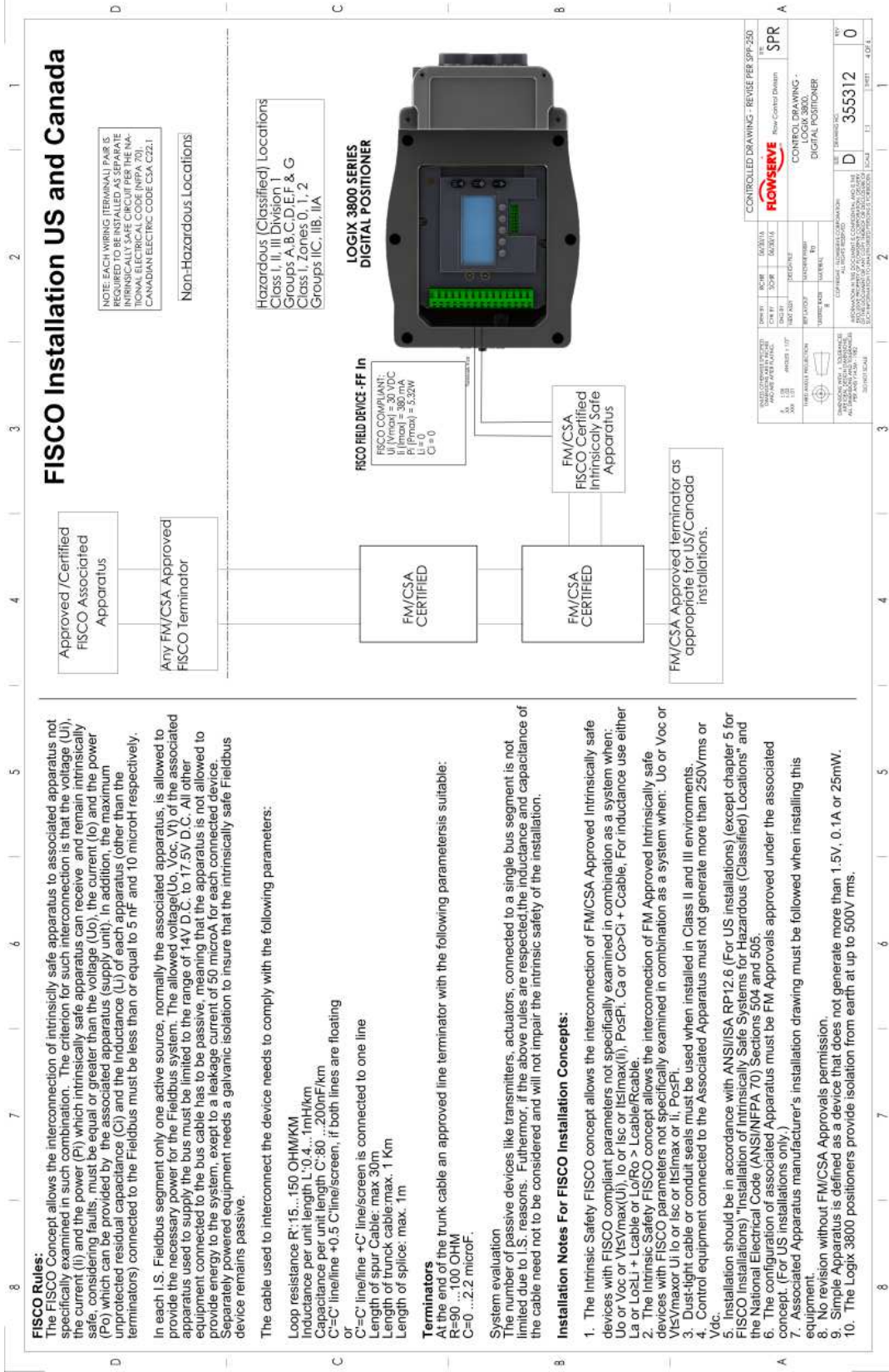

17.9 Control Drawing – FISCO Installation ATEX / IECEx

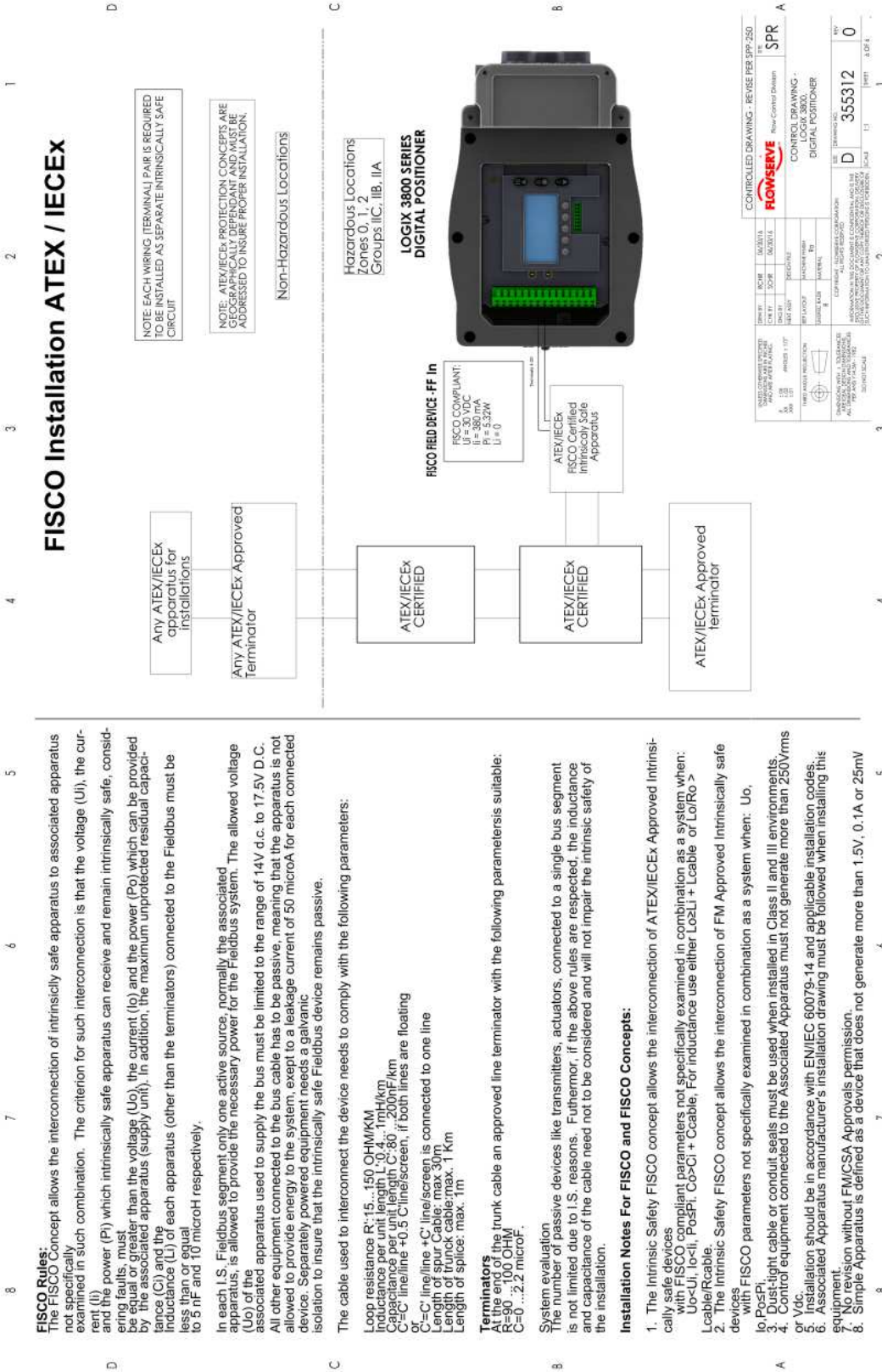

18 SIL 3 REQUIREMENTS FOR SAFETY INTEGRITY

This section provides information and additional user responsibilities to meet up to Safety Integrity Level 3 (SIL 3) per IEC 61508. This does not apply to Fieldbus models. This applies only to positioners powered by 4-20 mA.

18.1 Safety Function

The Logix 3800 positioner moves to fail-safe state upon the removal of analog input power (providing less than 3.6 mA);

18.2 Fail Safe State

The fail-safe state for a positioner is when the relay valve is at less than 5% of full travel such that output port A is venting.

NOTE: *The failsafe state above represents the fail-safe state of the positioner. The valve fail-safe state may be different depending on spring configuration and tubing. Ensure the fail-safe valve state is appropriate for your application.*

18.3 Time to Move to Fail Safe State

The Logix 3800 positioner relay may take up to 0.47 seconds to move from fully energized (using tight shutoff) to the de-energized (fail safe) state. The Logix 3800 positioner relay may take up to 0.30 seconds to move from a controlling state to the de-energized (fail safe) state.

NOTE: *The valve will take longer to move than the positioner relay. To accurately assess timing of the valve movement, measurements must be taken after the entire system is installed. Process fluid pressure may also affect the timing of valve movement.*

18.4 Positioner Model Selection and Specification

Any Logix 3800 positioner can be used for up to SIL 3 applications as stated above.

18.5 Installation

Verify installation of the positioner is secure and correct according to this manual. Ensure tubing is configured to the actuator so that the fail-safe state of the positioner matches the desired fail-safe state of the valve.

18.6 Required Configuration Settings

Properly configure the following user settable options for the individual application to provide the designed safety integrity for that application.

- It is recommended to calibrate the command input. The safety function is independent of software, however, the

software controls will correlate better with the safety function if the command input is calibrated.

- It is recommended to lock the local interface to prevent unintended adjustments of the settings by an unauthorized user.

18.7 Maximum Achievable SIL

The Logix 3800 positioner covered by this safety manual is suitable for use in a low demand mode of operation Safety Integrity Functions (SIF) up to SIL 2 in simplex (1oo1) and SIL 3 in redundant (1oo2) configurations. The achieved SIL for a particular SIF needs to be verified by PFD_{AVG} calculation for the entire SIF including the failure rates of the associated sensors and valves that are also part of the SIF.

For details, contact your FLOWSERVE representative for Failure Mode, Effects, and Diagnostics Analysis (FMEDA) report number FLO 17-02-127 R001 for Logix 3800.

18.8 Reliability data

For reliability data, a detailed Failure Mode, Effects, and Diagnostics Analysis (FMEDA) report has been prepared and is available from FLOWSERVE with all failure rates and failure modes for use in SIL verification. See FMEDA report number FLO 17-02-127 R001 for Logix 3800.

NOTE: *The failure rates of the associated sensors, logic solver, valves and actuators need to be accounted for in the Safety Instrumented Function (SIF) level PFD_{AVG} calculation.*

18.9 Lifetime limits

The expected lifetime of the Logix 3800 positioner is approximately ten years. The reliability data listed the FMEDA report is only valid for this period. The failure rates of the Logix 3800 positioner may increase sometime after this period. Reliability calculations based on the data listed in the FMEDA report for lifetimes beyond ten years may yield results that are too optimistic, i.e. the positioner may not achieve the calculated Safety Integrity Level.

18.10 Proof Testing

The objective of proof testing when used in a low demand mode of operation is to detect failures within the Logix 3800 positioner, and its associated sensors and actuators that may not be detected by the normal self-diagnostics. Of main concern are undetected failures that prevent the safety instrumented function from performing its intended function.

The reliability calculations determine the frequency of the proof tests (or the proof test interval) for the safety instrumented functions applied to the Logix 3800 positioner. Perform the proof tests at least as frequently as specified in the calculation to maintain required safety integrity of the safety instrumented function.

Specifically, execute the following tests during a proof test. Document the results of the proof test and include it as part of a plant safety management system.

NOTE: Report any *positioner failures that are detected to FLOWSERVE*.

The first test is a partial stroke test (PST). Ways to configure and run the PST are:

- Use a HART communicator such as a Handheld with the Logix 3800 DD.
- Use software such as the ValveSight DTM for Logix 3800 positioners.

Once the PST parameters have been configured, the test can be run:

- By using the LCD display menu.
- Or by pressing and holding the button for 3 seconds.

A partial stroke test can also be run from an external control system such as a DCS, but no pass/fail results or records will be obtained or stored by the positioner.

NOTE: If the PST fails, an error message will appear. This message will clear after the completion of a successful PST. The message can also be cleared by entering the hot key sequence, Section 11.6, or through the DTM.

Steps for Partial Stroke Test (PST)

Step Action

1. Verify the control loop is ready for valve movement in the amount set for the PST.
2. Execute the PST.
3. View the results and check errors generated by the PST using the DTM, the DD, the LCD display menu, or by observing the blink codes on the positioner.

After executing the test listed above, the Logix 3800 will have a proof test coverage of 73% (for double acting valves), or 56% (for single acting valves). The proof test will detect no additional failure modes after implementing PST. Failure modes not covered include possible valve sticking (in the travel range not tested), leaking of the valve seat (for fail closed valves), and operation of the electronic shut-down circuit.

Steps for Proof Test

Step Action

1. Verify the control loop is ready for valve movement to the fail-safe state (defined by the application).
2. Bypass the safety PLC or take other appropriate action to avoid a false trip.
3. Set the analog input command to less than 3.68 mA, but greater than 3.60
4. Ensure that the attached valve moves to fully to the safe state and has moved to that position within the allowed time. This will test for all failures that could prevent the closure of the valve, including electronic and mechanical faults, as well as valve faults.
5. Inspect the Logix 3800 Valve Positioner for any visible damage or contamination and ensure the follower arm has sufficient spring bias if applicable.
6. Check the errors generated by accessing the Alerts and Alarms menu on the LCD or the Alarm Annunciator in the DTM or other HART system.
7. Remove the bypass from the safety PLC or otherwise, restore normal operation.

After executing the tests listed above and if PST has not been implemented as a diagnostic, the Logix 3800 will have proof test coverage of 97% (for double acting valves) and 95% (for single acting valves). The proof test will detect no additional failure modes after the proof test is complete. Failure modes not covered include possible leaking of the valve seat for fail closed valves.

18.11 Maintenance

Follow routine maintenance. See section 13, Maintenance – Troubleshooting.

18.12 Repair and Replacement

Report any failure of the FLOWSERVE Logix 3800 Valve Positioner immediately to FLOWSERVE. Replace faulty components according to section 18 of this manual or return the positioner to FLOWSERVE for service. With experience and the right parts, repair times for any component can be less than an hour. Assume a 24-hour mean time to repair for safety availability calculations.

18.13 Training Requirements

A service technician trained in the installation and maintenance of process instrumentation activities should perform activities specified in this manual.

APPENDIX A – LCD MENU TREE OVERVIEW

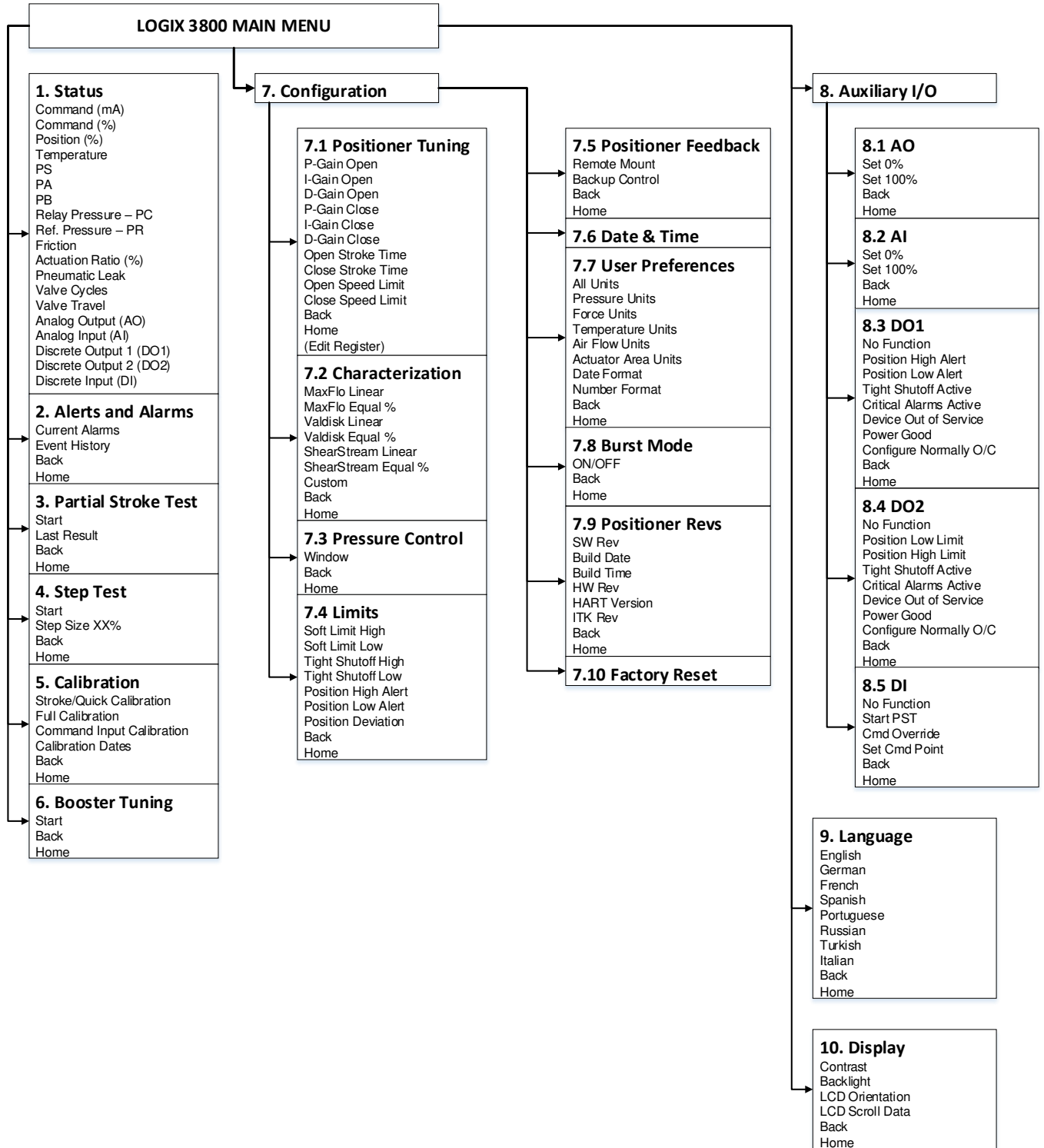

APPENDIX B – LCD MENU TREE DESCRIPTIONS

Menu Feature	Description	Menu Location	HART Std	HART Pro	FF Std	FF Pro
Status	The Status menu is used to view information about the configuration and operation of the system.	1	•	•	•	•
Command (mA)	Command (mA) displays the final command in mA.	1.1	•	•		
Command (Percent)	Command (Percent) displays the final command in %.	1.2	•	•	•	•
Position (Percent)	Position (Percent) displays the valve position in %.	1.3	•	•	•	•
Temperature (User Units)	Temperature (User Units) displays the temperature inside the positioner.	1.4	•	•	•	•
PS (User Units)	PS (User Units) displays the supply pressure.	1.5		•		•
PA (User Units)	PA (User Units) displays the pressure in port A. This is the primary port if using a poppet-style relay module.	1.6		•		•
PB (User Units)	PB (User Units) displays the pressure in port B.	1.7		•		•
Relay Pressure PC (User Units)	PC (User Units) displays the pressure in port C. "Pc" is the "control" pressure or the amount of pressure being used to actuate the relay. It should be in the range 0 to 18.8 psi.	1.8		•		•
Reference Pressure PR (User Units)	PR (User Units) displays the pressure in port R. This port R is the atmospheric reference pressure. It is subtracted from the others.	1.9		•		•
Friction (User Units)	Friction (User Units) displays the friction of the actuator/valve assembly.	1.10		•		•
Actuation Ratio (Percent)	Actuation Ratio (Percent) displays the force required to actuate the valve as a percentage of the total force available. The value is an estimate of the force that would be required to move the valve to the end of travel, fully compressing the actuator spring(s).	1.11		•		•
Pneumatic Leak (User Units)	Pneumatic Leak (User Units) is an estimate of a leak in addition to regular air consumption.	1.12		•		•
Valve Cycles (Cycles)	Valve Cycles (Cycles) are counted each time the positioner changes direction. The movement must be beyond a dead-band window. This window is set to 0.5% as a default, but can be changed using the DTM.	1.13	•	•	•	•
Valve Travel (Percent)	Valve Travel (Percent) is counted in small increments every time the valve moves beyond the dead-band window. The display of travel is in % of full stroke.	1.14	•	•	•	•
Analog Output (AO)	The Analog Output provides a 4-20 mA feedback mechanism, indicating the position of the valve, to the host system.	1.15	•	•		
Analog Input (AI)	The Analog Input provides a 4-20 mA input mechanism to interface with process variable transmitters.	1.16		•		
Discrete Output 1 (DO1)	The Discrete Output provides a way to indicate to the host system that a predefined condition has occurred.	1.17		•		
Discrete Output 2 (DO2)	The Discrete Output provides a way to indicate to the host that a predefined condition has occurred.	1.18		•		
Discrete Input (DI)	The Discrete Input provides a way for the user to either trigger a PST or command the valve to a predetermined set point.	1.19		•		
Back		1.20	•	•	•	•
Alerts and Alarms	The Alerts and Alarms menu show current and past alarms, warnings, alerts, and calibrations.	2	•	•	•	•
Current Alarms	Current Alarms displays all events that are actively sounding.	2.1	•	•	•	•

A
B

Menu Feature	Description	Menu Location	HART Std	HART Pro	FF Std	FF Pro
Event History	Event History displays past 32 events including alarms, warnings, alerts, and calibrations. Displayed is the event that occurred most recently, first (event 32) with later events recorded below. Each event would have a timestamp and shows if it was turning on or off.	2.2	•	•	•	•
Back		2.3	•	•	•	•
Partial Stroke Test	The Partial Stroke Test (PST) menu provides the user the ability to start a PST and see the results of the latest PST.	3	•	•	•	•
Start	Start allows the user to initialize the (PST).	3.1	•	•	•	•
Last Result	Last Result shows “Pass” or “Fail” from the last PST attempt.	3.2	•	•	•	•
Back		3.3	•	•	•	•
Step Test	The purpose of the step test is to allow the user to easily evaluate the performance of the positioner from the local interface	4	•	•	•	•
Start	Start allows the user to initialize the step test.	4.1	•	•	•	•
Step Size XX%	Defaulted to 50%. The Step Size shall be user settable from 2% to 100%	4.2	•	•	•	•
Back		4.3	•	•	•	•
Calibration	The Calibration menu allows the user to calibrate the positioner’s sensors. The positioner can accurately control with only a Quick-Cal. Typically this is all that is needed. Calibrate the friction calibration of the positioner when upgrading to Pro diagnostics.	5	•	•	•	•
Stroke/Quick Calibration	Stroke/Quick Calibration starts an automatic calibration of the position feedback sensor. The stroke calibration determines the closed (0%) and open (100%) positions of the valve and gathers information about the response of the valve (such as valve stroke time) to determine the gains. The gains automatically are then set. After a stroke calibration, the positioner is ready to control.	5.1	•	•	•	•
Full Calibration		5.2		•		•
Command Input Calibration	Command Input Calibration is used to adjust the input range. Set the lowest current (Set 0%) and the highest current used (Set 100%). The default input range is 4 to 20 mA. The “Set 0%” value must be lower than the “Set 100% value.	5.3	•	•		
Calibration Dates	Calibration Dates lists the most recent date of each calibration.	5.4	•	•	•	•
Back		5.5	•	•	•	•
Booster Tuning	The purpose of the Booster Tuning is to allow the user to more easily tune flow boosters.	6	•	•	•	•
Start	Start allows the user to initialize the booster tuning.	6.1	•	•	•	•
Back		6.2	•	•	•	•
Configuration						
Positioner Tuning		7	•	•	•	•
P-Gain Open	The Configuration – Positioner Tuning menu allows the user to adjust individual tuning parameters manually. All tuning parameters are automatically set to optimal values during Quick-Cal. Typically a Quick-Cal is all that is needed for positioner tuning.	7.1	•	•	•	•
P-Gain Open			•	•	•	•

Menu Feature	Description	Menu Location	HART Std	HART Pro	FF Std	FF Pro
I-Gain Open	I-Gain is the proportional, integral, and differential element of the feedback algorithm. This gain is different for the opening and closing directions because typically responsiveness is different in each direction.	7.1.2	•	•	•	•
D-Gain Open	D-Gain is the proportional, integral, and differential element of the feedback algorithm. This gain is different for the opening and closing directions because typically responsiveness is different in each direction.	7.1.3	•	•	•	•
P-Gain Close	P-Gain is the proportional, integral, and differential element of the feedback algorithm. This gain is different for the opening and closing directions because typically responsiveness is different in each direction.	7.1.4	•	•	•	•
I-Gain Close	I-Gain is the proportional, integral, and differential element of the feedback algorithm. This gain is different for the opening and closing directions because typically responsiveness is different in each direction.	7.1.5	•	•	•	•
D-Gain Close	D-Gain is the proportional, integral, and differential element of the feedback algorithm. This gain is different for the opening and closing directions because typically responsiveness is different in each direction.	7.1.6	•	•	•	•
Open Stroke Time	Open Stroke Time is the fastest time it took the valve to stroke from 0% to 100% during Quick-Cal.	7.1.7	•	•	•	•
Close Stroke Time	Close Stroke Time is the fastest time it took the valve to stroke from 100% to 0% during Quick-Cal.	7.1.8	•	•	•	•
Open Speed Limit	Open Speed Limit and Closed Speed Limit are used to prevent the valve from moving too quickly. Speed limits help when the process is sensitive to rapid flow or pressure changes. This shows the time (in seconds) that the positioner will allow the valve to travel a full stroke. This speed limit applies to smaller movements of the valve too.	7.1.9	•	•	•	•
Close Speed Limit	Open Speed Limit and Closed Speed Limit are used to prevent the valve from moving too quickly. Speed limits help when the process is sensitive to rapid flow or pressure changes. This shows the time (in seconds) that the positioner will allow the valve to travel a full stroke. This speed limit applies to smaller movements of the valve too.	7.1.10	•	•	•	•
Back		7.1.11	•	•	•	•
(Edit Register)	Reserved for service only for writing and reading variables in system.	7.1.12	•	•	•	•
Characterization	The Configuration – Characterization menu allows the user to change the characterization of the command. This allows a better match between the input command and the actual fluid flow through the valve. This feature is typically used with valves that have non-linear flow characteristics. The positioner makes a correction by applying an adjustment to the input command according to a characterization curve. The table in this appendix shows the available characterization curve options. Each point of the Custom curve can be adjusted using the ValveSight DTM.	7.2	•	•	•	•
MaxFlo Linear	See Appendix C – Programmed Flow Characterization Options for characteristic curve data and illustrated curves	7.2.1	•	•	•	•
MaxFlo Equal %	See Appendix C – Programmed Flow Characterization Options for characteristic curve data and illustrated curves	7.2.2	•	•	•	•
Valdisk Linear	See Appendix C – Programmed Flow Characterization Options for characteristic curve data and illustrated curves	7.2.3	•	•	•	•
Valdisk Equal %	See Appendix C – Programmed Flow Characterization Options for characteristic curve data and illustrated curves	7.2.4	•	•	•	•

B

Menu Feature	Description	Menu Location	HART Std	HART Pro	FF Std	FF Pro
ShearStream Linear	See Appendix C – Programmed Flow Characterization Options for characteristic curve data and illustrated curves	7.2.5	•	•	•	•
ShearStream Equal %	See Appendix C – Programmed Flow Characterization Options for characteristic curve data and illustrated curves	7.2.6	•	•	•	•
Custom	Select Custom for a standard 30:1 linear, equal percent rangeability curve. The curve may be customized point-by-point. To modify the Custom curve, use the ValveSight DTM. See Appendix C – Programmed Flow Characterization Options for characteristic curve data and illustrated curves	7.2.7	•	•	•	•
Back		7.2.8	•	•	•	•
Pressure Control	The Configuration (Pressure Control) menu allows the user to change the size of the pressure control window. This window becomes active when the Valve Stability Switch is set to “Hi.” The Valve Stability Switch optimizes the response for valves and actuators with high friction levels. When set to “Hi,” it slightly slows the response and will normally stop limit cycling that can occur on high friction valves.	7.3	•	•	•	•
Window	When the position of the valve gets within the pressure control window, the positioning algorithm will change to pressure control. This means the pressures will be held constant (locked), improving the stability of the valve position.	7.3.1	•	•	•	•
Back		7.3.2	•	•	•	•
Limits	Limits allows the user to limit the movement of the valve. Shutoff allows the user to shut the valve with all available force tightly.	7.4	•	•	•	•
Soft Limit High	This feature is used to simulate physical blocks on the valve that restrict movement past a set point. Once the Soft Limit is set, the positioner will not attempt to move the valve position (final command) beyond the set point, regardless of the analog or digital command input signal.	7.4.1	•	•	•	•
Soft Limit Low	This feature is used to simulate physical blocks on the valve that restrict movement past a set point. Once the Soft Limit is set, the positioner will not attempt to move the valve position (final command) beyond the set point, regardless of the analog or digital command input signal.	7.4.2	•	•	•	•
Tight Shutoff High	This feature is used to close or open the valve tightly. It is used when a tight seal is needed or when debris or friction may otherwise interfere with complete closure. When the valve is commanded past the Shutoff points, the pilot relay will direct full supply pressure to the appropriate port, applying all available force to close (or open) the valve. The Shutoff points apply to the Final Command.	7.4.3	•	•	•	•
Tight Shutoff Low	This feature is used to close or open the valve tightly. It is used when a tight seal is needed or when debris or friction may otherwise interfere with complete closure. When the valve is commanded past the Shutoff points, the pilot relay will direct full supply pressure to the appropriate port, applying all available force to close (or open) the valve. The Shutoff points apply to the Final Command.	7.4.4	•	•	•	•
Position High Alert	Position High Alert Algorithm for customer's choice	7.4.5	•	•	•	•
Position Low Alert	Position Low Alert Algorithm for customer's choice	7.4.6	•	•	•	•
Position Deviation	Position Deviation Alert Algorithm for customer's choice	7.4.7	•	•	•	•
Back		7.4.8	•	•	•	•
Position Feedback	The positioner shall attempt to control using the pressure sensors as valve position feedback in the event that the feedback linkage breaks.	7.5	•	•	•	•

Menu Feature	Description	Menu Location	HART Std	HART Pro	FF Std	FF Pro
Remote Mount	The Remote Mount ADC Count	7.5.1	•	•	•	•
Backup Control	The positioner shall support a Back-up Control Mode wherein the positioner uses the pressures to estimate the valve position when the feedback linkage is broken.	7.5.2		•		•
Back		7.5.3	•	•	•	•
Date & Time	Use the Up and Down buttons to set the time and date. The format of the time and date is displayed above the input fields.	7.6	•	•	•	•
User Preferences	The User Preferences menu allows the user to format how information is displayed.	7.7	•	•	•	•
All Units	(North American, S/)	7.7.1	•	•	•	•
Pressure Units	(psi, bar, kg/cm2, kPa)	7.7.2		•		•
Force Units	(lbf, kg, N)	7.7.3		•		•
Temperature Units	(degrees F, degrees C)	7.7.4	•	•	•	•
Air Flow Units	(scfm, slpm, slph, Nm3/hr)	7.7.5		•		•
Actuator Area Units	(in2, cm2)	7.7.6	•	•	•	•
Date Format	(Mon/Day/Year, Day.Mon.Year)	7.7.7	•	•	•	•
Number Format	(Decimal Point, Comma)	7.7.8	•	•	•	•
LCD Orientation	(Standard, Rotate 180°)	7.7.9	•	•	•	•
Back		7.7.10	•	•	•	•
Burst Mode	Burst Mode continuously transmits HART information.	7.8	•	•		
ON/OFF	On/Off – Use this feature to turn burst mode on and off.	7.8.1	•	•		
Back		7.8.2	•	•		
Positioner Revs		7.9	•	•	•	•
SW Rev	The revision of the embedded software.	7.9.1	•	•	•	•
Bld Date	The date of the embedded software build.	7.9.2	•	•	•	•
Bld Time	The time of day of the embedded software build.	7.9.3	•	•	•	•
HW Rev	The revision of the main board.	7.9.4	•	•	•	•
HART Ver	The revision of the HART protocol (6, or 7).	7.9.5	•	•		
ITK Rev	The ITK revision.	7.9.6			•	•
Back		7.9.7	•	•	•	•
Factory Reset	Use this feature to reset all variables to their factory default state. All of the internal variables are reset including calibration to factory defaults. The positioner must be re-calibrated after a factory reset. Tag names and other user configured limits, alarm settings, and valve information will also be lost and require restoring. A factory reset will always reset the command source to analog 4-20 mA.	7.10	•	•	•	•
Auxiliary I/O	The terminal block gives options for analog output (AO), Analog input (AI), Discrete Input (DI) and Discrete Output (DO) 1 and 2.	8	•	•		
AO		8.1	•	•		
Set 0%	Set the current (mA) that will correspond to the 0% (closed) valve position.	8.1.1	•	•		
Set 100%	Set the current (mA) that will correspond to the 100% (open) valve position.	8.1.2	•	•		

B

Menu Feature	Description	Menu Location	HART Std	HART Pro	FF Std	FF Pro
Back		8.1.3	•	•		
AI		8.2		•		
Set 0%	Set the current (mA) that will correspond to the 0% (closed) valve position.	8.2.1		•		
Set 100%	Set the current (mA) that will correspond to the 100% (open) valve position.	8.2.2		•		
Back		8.2.3		•		
DO1		8.3		•		
No Function	No alert	8.3.1		•		
Position High Alert	When Position High Alert is active, the DO1 become active.	8.3.2		•		
Position Low Alert	When Position Low Alert is active, the DO1 become active.	8.3.3		•		
Tight Shutoff Active	When Tight Shutoff Active is active, the DO1 become active.	8.3.4		•		
Critical Alarms Active	When Critical Alarms Active is active, the DO1 become active.	8.3.5		•		
Device Out of Service	When Device Out of Service is active, the DO1 become active.	8.3.6		•		
Power Good	When Power Good is active, the DO1 become active.	8.3.7		•		
Configure Normally O/C	The customer's choice for Normally Open or Close circuit.	8.3.8		•		
Back		8.3.9		•		
DO2		8.4		•		
No Function	No alert	8.4.1		•		
Position Low Limit	When Position High Alert is active, the DO2 become active.	8.4.2		•		
Position High Limit	When Position Low Alert is active, the DO2 become active.	8.4.3		•		
Tight Shutoff Active	When Tight Shutoff Active is active, the DO2 become active.	8.4.4		•		
Critical Alarms Active	When Critical Alarms Active is active, the DO2 become active.	8.4.5		•		
Device Out of Service	When Device Out of Service is active, the DO2 become active.	8.4.6		•		
Power Good	When Power Good is active, the DO2 become active.	8.4.7		•		
Configure Normally O/C	The customer's choice for Normally Open or Close circuit.	8.4.8		•		
Back		8.4.9		•		
DI		8.5		•		
No Function	No Action	8.5.1		•		
Start PST	Trigger to start a PST	8.5.2		•		
Cmd Override	Trigger to start a Cmd Override	8.5.3		•		
Set Cmd Point	Change Set Cmd Point variable.	8.5.4		•		
Back		8.5.5		•		
Language		9	•	•	•	•
English		9.1	•	•	•	•
German		9.2	•	•	•	•
French		9.3	•	•	•	•
Spanish		9.4	•	•	•	•
Portuguese		9.5	•	•	•	•

Menu Feature	Description	Menu Location	HART Std	HART Pro	FF Std	FF Pro
Russian		9.6	•	•	•	•
Turkish		9.7	•	•	•	•
Italian		9.8	•	•	•	•
Back		9.9	•	•	•	•
Display		10	•	•	•	•
Contrast	LCD Contrast. Customer's Choice	10.1	•	•	•	•
Backlight	LCD Backlight. Customer's Choice	10.2	•	•	•	•
LCD Orientation	(Standard, Rotate 180°)	10.3	•	•	•	•
Back		10.4	•	•	•	•

APPENDIX C – PROGRAMMED FLOW CHARACTERIZATION OPTIONS

The characterization menu allows the user to change the characterization of the command. This allows a better match between the input command and the actual fluid flow through the valve. This feature is typically used with valves that have non-linear flow characteristics. The positioner makes a correction by applying an adjustment to the input command according to a characterization curve. The table below shows the available characterization curve options. Each point of the Custom curve can be adjusted using the ValveSight DTM.

Command Input	Final Command							
	Characterization DIP set to "Linear"	Characterization DIP set to "Other"						
	Linear	MaxFlo Linear	MaxFlo =%	Valdisk Linear	Valdisk =%	Shear-Stream Linear	Shear-Stream =%	Custom (Default) (Linear =%)
0.0	0.00	0.00	0.00	0.00	0.00	0.00	0.00	0.00
5.0	5.00	6.50	1.00	13.00	4.00	25.00	8.00	0.62
10.0	10.00	11.60	2.00	20.00	6.00	35.00	14.00	1.35
15.0	15.00	16.20	3.00	26.25	7.80	44.00	17.00	2.22
20.0	20.00	20.50	4.40	32.10	9.30	50.20	21.00	3.25
25.0	25.00	24.60	5.80	37.50	11.50	55.50	24.00	4.47
30.0	30.00	28.50	7.40	42.60	14.00	60.20	27.50	5.91
35.0	35.00	32.40	9.30	47.40	16.50	64.30	31.50	7.63
40.0	40.00	36.20	11.20	51.80	19.30	68.00	35.50	9.66
45.0	45.00	40.00	13.50	56.00	22.50	71.50	39.50	12.07
50.0	50.00	43.80	16.10	60.00	26.00	74.70	43.90	14.92
55.0	55.00	47.60	19.10	63.60	30.00	77.70	48.10	18.31
60.0	60.00	51.50	22.40	67.20	34.70	80.50	52.80	22.32
65.0	65.00	55.50	26.20	70.60	39.60	83.20	57.40	27.08
70.0	70.00	59.50	30.60	73.90	45.10	85.90	62.40	32.71
75.0	75.00	63.80	35.70	77.20	51.30	88.40	67.50	39.40
80.0	80.00	68.20	41.70	81.30	57.80	90.80	72.90	47.32
85.0	85.00	73.00	48.90	84.00	64.80	93.20	78.60	56.71
90.0	90.00	78.40	57.70	87.80	72.50	95.50	84.70	67.84
95.0	95.00	85.00	69.20	92.10	81.30	97.80	91.20	81.03
100.0	100.00	100.00	100.00	100.00	100.00	100.00	100.00	100.00

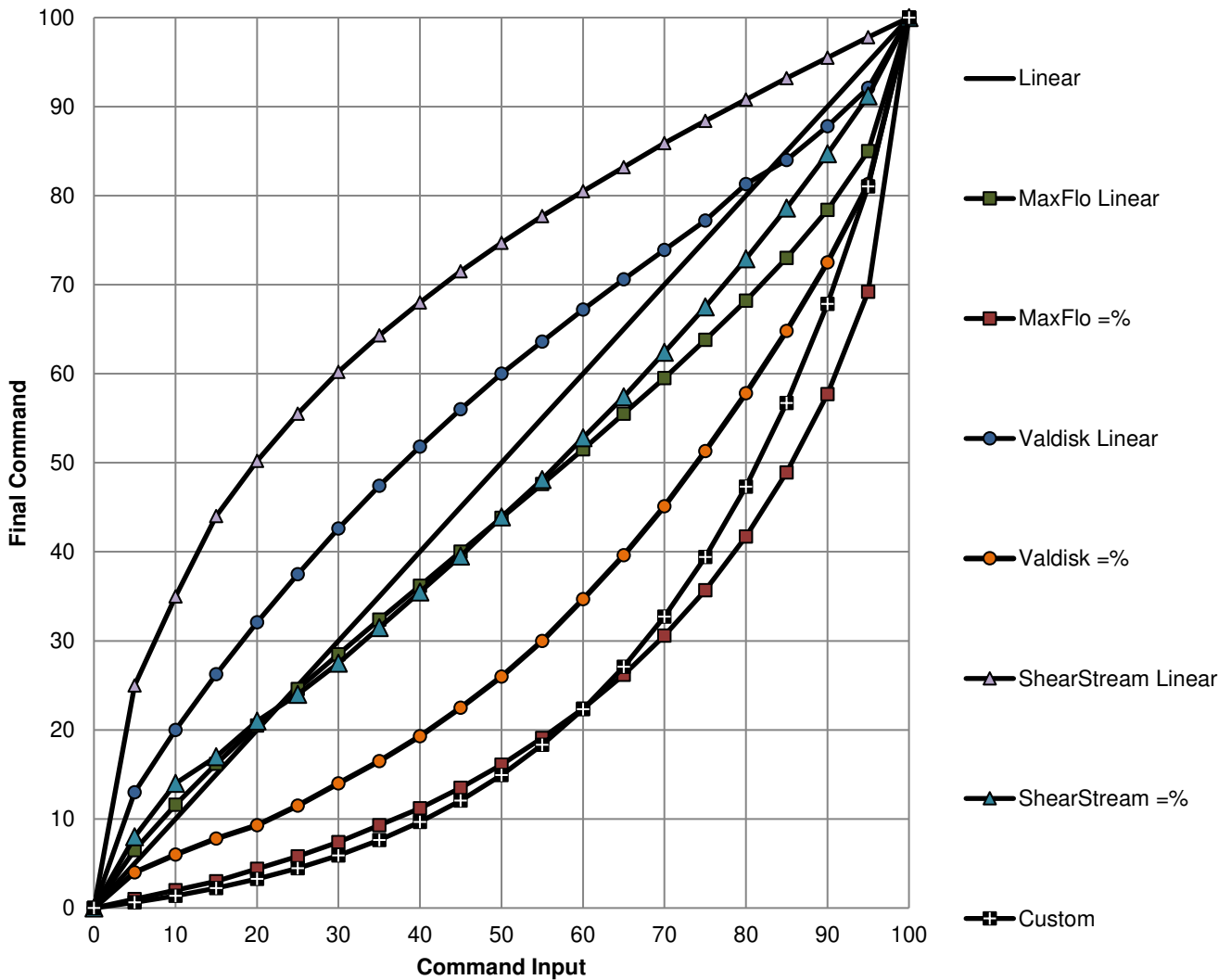

Figure 53: Characterization Curve Options

APPENDIX D – 4-BLINK STATUS CODES

↻ **NOTE:** Not all codes apply to all positioners. The order of sorting is **G B Y O R**.

Color Code	Status	Color Code	Status
G G G G	Power ON	G R O O	Analog In Set 100%
G G G G	Calibration Succeeded	G R R Y	Jog Command Mode
G G G G	Pressure Control Locked	B B B G	Software Download Complete
G G G B	Continuous Stroke Test Mode	B B B B	Software Download in Progress
G G G Y	Tight Shut Off Mode	B B B Y	Software Download Waiting
G G G O	Relay Calibration in Range	B B B O	Software Download Paused
G G B B	Backup Control Mode	B B B R	Software Download Fail Warning
G G Y G	Local Interface Off	Y G G G	Position High Limit Alert
G G Y Y	Digital Command Mode	Y G G G	Position Low Limit Alert
G G Y R	Initializing	Y G G Y	Valve Cycles Warning
G G O O	DI Active Alert	Y G G Y	Valve Travel Warning
G G R R	Test Mode	Y G G Y	Actuator Cycles Warning
G B B B	Squawk Mode	Y G G Y	Actuator Travel Warning
G B Y O	Relay Calibration - Adjust Clockwise	Y G G Y	Bellows Cycles Warning
G Y G Y	Soft Stop High Limit Alert	Y G G Y	Bellows Travel Warning
G Y G Y	Soft Stop Low Limit Alert	Y G G Y	Relay Cycles Warning
G Y Y G	Pressure Calibration Required	Y G G Y	Relay Travel Warning
G Y Y R	Partial Stroke Test Scheduled	Y G G R	Jog Calibration Set 100% Position
G Y O G	AO Input Set 0%	Y G B B	Relay Calibration Settle
G Y O O	AO Input Set 100%	Y G Y G	Position Recovery Mode
G O Y Y	Calibration Type Set	Y G R Y	Continuous Stroke Test Failed Warning
G R G G	Signature or Partial Stroke Test in Progress	Y G R R	Partial Stroke Test Failed Warning
G R G R	DI Command Override	Y Y G G	Temperature High Warning
G R Y G	Command Input Set 0%	Y Y G G	Temperature Low Warning
G R Y Y	Command Input Set 100%	Y Y G Y	Valve Opened Too Far Warning
G R O Y	Analog In Set 0%	Y Y G Y	Valve Closed Too Far Warning

Color Code	Status	Color Code	Status
YYGR	Supply Pressure High Warning	YRRY	Piezo Voltage Low Warning
YYYG	Supply Pressure Low Warning	YRRO	Vent Blocked Warning
YYYY	Actuation Ratio Warning	YRRR	Spring Unable to Fail Safe Warning
YYYO	System Exception Warning	RGGG	Command Input Range Too Small
YYYO	CPU Usage Warning	RGGG	Command Input Below ADC Range
YYYO	RAM Cyclic Redundancy Check Error	RGGG	Command Input Above ADC Range
YYYR	NVMEM CRC Error	RGGB	Analog Input Range Too Small
YYYR	Flash CRC Error	RGGB	Analog Input Below ADC Range
YYOG	Button Stuck On	RGGB	Analog Input Above ADC Range
YYOY	Command Frequency Warning	RGGY	Position Range Too Small
YYOY	Command Amplitude Warning	RGGO	Pressure Regulator Error
YYOO	Position Frequency Warning	RGGR	Inner Loop Offset Time Out
YYOO	Position Amplitude Warning	RGBG	Remote Mount Out-of-Range
YRGY	Friction Low Warning	RGYG	Settle Time Out
YRGR	Friction High Warning	RGY Y	No Motion Time Out
YRYG	Stroke Calibration in Progress	RGYR	Analog Output Range Too Small
YRYG	Feedback Calibration in Progress	RGOG	Fail Safe Position Error
YRYG	Pressure Calibration in Progress	RGOO	Relay Calibration Error
YRYG	Full Calibration in Progress	RGOR	Temperature Calibration Required
YRYG	Command Input Calibration in Progress	RGRG	Calibration Required
YRYG	Analog Input Calibration in Progress	RGRB	Position Feedback Calibration Required
YRYG	Analog Output Calibration in Progress	RGRY	Stroke Shift
YRYG	Relay Characterization in Progress	RGRY	Stroke Span Increase
YRYY	Backlash Warning	RGRY	Stroke Span Decrease
YRYO	Balance Pressure Warning	RGRR	Factory Reset State
YRYR	Pneumatic Leak Warning	RYGG	Valve Can't Open Alarm
YRRG	Low Battery Warning	RYGG	Valve Can't Shut Alarm
YRRY	Piezo Voltage High Warning	RYYG	Supply Pressure Low Alarm

D

Color Code	Status	Color Code	Status
R Y Y Y	Analog Output No Loop Power	R Y R R	Reference Voltage Error
R Y Y O	Analog Output Error	R Y R R	Reference Voltage Error
R Y Y R	Analog Input No Loop Power	R Y R R	Voltage ADC Error
R Y O Y	Command Frequency Alarm	R Y R R	Piezo Voltage Error
R Y O Y	Command Amplitude Alarm	R Y R R	Shunt Voltage Error
R Y O O	Position Frequency Alarm	R Y R R	Shunt Current Error
R Y O O	Position Amplitude Alarm	R O Y B	Relay Calibration Adjust Counter-Clockwise
R Y R G	Position Sensor Failure Alarm	R R G Y	Friction Low Alarm
R Y R Y	Port S Out of Range	R R G R	Friction High Alarm
R Y R Y	Port A Out of Range	R R Y G	Feedback Linkage Alarm
R Y R Y	Port B Out of Range	R R Y Y	Backlash Alarm
R Y R Y	Port C Out of Range	R R Y R	Relay Can't Open
R Y R Y	Port S Range Too Small	R R Y R	Relay Can't Shut
R Y R Y	Port A Range Too Small	R R Y R	Relay Sensor Failure
R Y R Y	Port B Range Too Small	R R Y R	Relay Type Unknown
R Y R Y	Port C Range Too Small	R R R B	Incompatible Software Alarm
R Y R Y	Port R Out-of-Range	R R R Y	Piezo Voltage High Alarm
R Y R Y	Port R Range Too Small	R R R Y	Piezo Voltage Low Alarm
R Y R Y	Pressure Sensor Failure	R R R O	Relay Inner Loop Offset Out-of-Range Warning
R Y R R	Supply Voltage Error	R R R R	Position Deviation Alarm
R Y R R	Supply Voltage Error		

APPENDIX E – STATUS CODE DESCRIPTIONS

Name	Description	Possible Solution	LED Color Code
Actuation Ratio Warning	The force required to control the system is close to the maximum available force. Actuation Ratio is based on the ratio of available force to the required force to fully actuate. Control may be lost if this ratio reaches 100%. It is affected by the process load, friction, spring force, and available supply pressure.	Increase the supply pressure. Reduce the friction. Check the actuator spring. Resize the actuator. Adjust user set limits.	Y Y Y Y
Actuator Cycles Warning	The actuator cycle limit has been exceeded. Each cycle represents two reversals of the direction of valve movement. The cycle counting criterion and count limit are set by the user to track the usage of the valve.	Follow routine procedures for maintenance when the limit is reached such as checking the actuator seals and lubrication. After maintenance, reset the travel accumulator.	Y G G Y
Actuator Travel Warning	The total accumulated actuator travel limit has been exceeded. The travel is accumulated in both directions. The travel counting criterion and limit are set by the user to track the usage of the valve.	Follow routine procedures for maintenance when the limit is reached such as checking the actuator seals and lubrication. After maintenance, reset the travel accumulator.	Y G G Y
Analog In Set 0%	An Analog Input Calibration has been started using the buttons (not LCD) and the positioner is waiting for the user to adjust the loop current to 0% and press the QUICK-CAL button to accept.	Complete the calibration.	G R O Y
Analog In Set 100%	An Analog Input Calibration has been started using the buttons (not LCD) and the positioner is waiting for the user to adjust the loop current to 100% and press the QUICK-CAL button to accept.	Complete the calibration.	G R O O
Analog Input Above ADC Range	During Command Loop Calibration, the 100% signal was out of the Analog to Digital Converter (ADC) range.	Replace the electronics assembly.	R G G B
Analog Input Below ADC Range	During Command Loop Calibration, the 0% signal was out of the Analog to Digital Converter (ADC) range.	Replace the electronics assembly.	R G G B
Analog Input Calibration in Progress	The command input calibration sequence is in progress.	The calibration can be canceled from the Auxiliary Input Calibration page of the DTM, from the handheld, or by briefly pressing all three buttons at once.	Y R Y G
Analog Input No Loop Power	The Auxiliary Input terminals have no loop power. The positioner previously detected power on the terminals.	Check terminal connection. Mask the alarm if the circuit is not used.	R Y Y R
Analog Input Range Too Small	During an Analog Input loop calibration, the difference between the signal at 0% and the signal at 100% was too small.	Recalibrate making sure to use a larger difference between command signal limits.	R G G B

E

Name	Description	Possible Solution	LED Color Code
Analog Output Calibration in Progress	The analog output calibration sequence is in progress.	The calibration can be canceled from the Analog Output Calibration page of the DTM, from the handheld, or by briefly pressing all three buttons at once.	Y R Y G
Analog Output Error	The Analog Output circuit is not producing the expected output current.	Check AO loop wiring and ensure adequate compliance voltage. Replace electronics assembly if the error persists.	R Y Y O
Analog Output No Loop Power	The Analog Output terminals have no loop power. The positioner previously detected power on the terminals.	Check terminal connection. Mask the alarm if the circuit is not used.	R Y Y Y
Analog Output Range Too Small	During a Analog Output calibration the difference between the milliamp signal at 0% and the milliamp signal at 100% was too small.	Recalibrate making sure to use a larger difference between signal limits. This notification can be cleared by briefly pressing the QUICK-CAL button.	R G Y R
AO Input Set 0%	An Analog Output Calibration has been started using the buttons (not LCD) and the positioner is waiting for the user to adjust the output current to 0% via the I and III Buttons, then press the QUICK-CAL button to accept.	Complete the calibration.	G Y O G
AO Input Set 100%	An Analog Output Calibration has been started using the buttons (not LCD) and the positioner is waiting for the user to adjust the output current to 0% via the I and III Buttons, then press the QUICK-CAL button to accept.	Complete the calibration.	G Y O O
Backlash Alarm	The amount of detected backlash has passed the user set alarm limit. This may affect valve stability.	Check the stem and actuator for loose components.	R R Y Y
Backlash Warning	The amount of detected backlash has passed the user set warning limit. This may affect valve stability.	Check the stem and actuator for loose components.	Y R Y Y
Backup Control Mode	The positioner is controlling the position based on actuator pressures instead of the feedback sensor.	The feedback linkage is probably broken or the feedback arm needs to be rotated because the sensor is out of range.	G G B B
Balance Pressure Warning	A pneumatic leak may exist or the relay balance pressure calibration may be incorrect.	Repair pneumatic leaks at the tubing junctions and actuator seals. Check relay balance pressure calibration.	Y R Y O
Bellows Cycles Warning	The bellows cycle limit has been exceeded. The bellows may be reaching the end of its fatigue life. Each cycle represents two reversals of the direction of bellows movement. The cycle counting criterion and count limit are set by the user to track the usage of the valve.	Follow routine procedures for maintenance when the limit is reached such as checking bellows for cracking or leaking. After maintenance, reset the cycle accumulator.	Y G G Y

Name	Description	Possible Solution	LED Color Code
Bellows Travel Warning	The bellows cycle limit has been exceeded. The bellows may be reaching the end of its fatigue life. Each cycle represents two reversals of the direction of valve movement. The cycle counting criterion and count limit are set by the user to track the usage of the valve.	Follow routine procedures for maintenance when the limit is reached such as checking bellows for cracking or leaking. After maintenance, reset the cycle accumulator.	Y G G Y
Button Stuck On	One of the three buttons (internal or external) is stuck in the on state.	Manipulate the buttons to attempt to unstick them. Clean the buttons with soft moist cloth to prevent buildup of debris.	Y Y O G
Calibration Required	A factory reset was performed and the positioner has not yet been calibrated. The unit will not respond to commands and will remain in the failsafe position until a calibration is successfully completed.	Perform a Stroke Calibration (QUICK-CAL) by holding the QUICK-CAL button down for 3 seconds, or perform a Pressure or Friction calibration if desired. See section 10, Operation – Calibration And Control for warnings.	R G R G
Calibration Succeeded	The last calibration succeeded.	Blink code will terminate automatically.	G G G G
Calibration Type Set	The user has selected a combination of key presses (Hot Key) that initiates a calibration. The positioner is waiting for the user to select the type of calibration to run.	Refer Appendix F – Hot Keys to see the calibration options.	G O Y Y
Command Input Set 0%	A Command Input Calibration has been started using the buttons (not LCD) and the positioner is waiting for the user to adjust the loop current to 0% and press the QUICK-CAL button to accept.	Complete the calibration.	G R Y G
Command Input Set 100%	A Command Input Calibration has been started using the buttons (not LCD) and the positioner is waiting for the user to adjust the loop current to 100% and press the QUICK-CAL button to accept.	Complete the calibration.	G R Y Y
Command Amplitude Alarm	The amplitude of the command signal is above the alarm limit. This could mean the control loop has larger swings than desirable.	Verify the limits are set at an appropriate level. Review the control loop parameters and equipment. Adjust as necessary.	R Y O Y
Command Amplitude Warning	The amplitude of the command signal is above the warning limit. This could mean the control loop has larger swings than desirable.	Verify the limits are set at an appropriate level. Review the control loop parameters and equipment. Adjust as necessary.	Y Y O Y
Command Frequency Alarm	The frequency of the command signal is above the alarm limit. This could mean the control loop is oscillating faster than normal.	Verify the limits are set at an appropriate level. Review the control loop parameters and equipment. Adjust as necessary.	R Y O Y
Command Frequency Warning	The frequency of the command signal is above the warning limit. This could mean the control loop is oscillating faster than normal.	Verify the limits are set at an appropriate level. Review the control loop parameters and equipment. Adjust as necessary.	Y Y O Y
Command Input Above ADC Range	During Command Loop Calibration, the 100% signal was out of the Analog to Digital Converter (ADC) range.	Replace the electronics assembly.	R G G G

E

Name	Description	Possible Solution	LED Color Code
Command Input Below ADC Range	During Command Loop Calibration, the 0% signal was out of the Analog to Digital Converter (ADC) range.	Replace the electronics assembly.	R G G G
Command Input Calibration in Progress	The command input calibration sequence is in progress.	The calibration can be canceled from the Command Calibration page of the DTM, from the handheld, or by briefly pressing all three buttons at once.	Y R Y G
Command Input Range Too Small	During a Command Loop Calibration, the difference between the signal at 0% and the signal at 100% was too small. The system is designed to accept a difference greater than 5 mA.	Recalibrate making sure to use a larger difference between command signal limits. The difference must exceed 5 mA.	R G G G
Continuous Stroke Test Failed Warning	During the continuous stroke test, the valve did not move after 5 consecutive attempts. This could mean the valve has increased friction, a change in process load or inadequate supply pressure.	Check friction, supply pressure and other alarms or warnings that would indicate difficulty in moving the valve. Check packing, and air supply. The warning will clear when the CST function is turned off or when a successful attempt to move the valve occurs.	Y G R Y
Continuous Stroke Test Mode	When there is no variation in the command input, this feature is deliberately moving the valve as little as possible in order to perform diagnostics and ensure the valve is functioning.	If more stability is required, turn off Continuous Stroke Test mode, or configure the rate of travel, period, and allowable movement using the Continuous Stroke page of the DTM.	G G G B
CPU Usage Warning	The CPU usage is too high.	Update the firmware.	Y Y Y O
DI Active Alert	The voltage to the DI has changed, triggering an action defined by the user.	No action is required. The function of the DI can be set in the DTM, using a handheld, or from the LCD menu.	G G O O
DI Command Override	The a Discrete Input (DI) has been configured to override the input command, positioning the valve at a preconfigured set point. The DI signal is active and the positioner is attempting to control the valve at the set point.	Configure the DI function and set point using the menu, a handheld or the Configuration page of the DTM.	G R G R
Digital Command Mode	The input command is set by a digital HART command instead of the 4-20 mA signal.	The input command source can be changed back to the 4-20 mA signal by using a handheld, the Dashboard page of the DTM, or performing a manual Command Reset. Perform the Command Reset by holding both the I and III buttons and briefly pressing the QUICK-CAL button.	G G Y Y
Factory Reset State	The positioner is in factory reset state. Calibration is required to enable control.	Perform a Stroke Calibration (QUICK-CAL).	R G R R
Fail Safe Position Error	The fail direction (on loss of air) that the user selected does not match the fail direction detected by the positioner.	Check the Air to Open / Air to Close DIP switch on the positioner. Also, review the actuator spring and tubing configuration.	R G O G

Name	Description	Possible Solution	LED Color Code
Feedback Calibration in Progress	A feedback calibration sequence is in progress. Turn the follower arm 2 full rotations over 10 seconds.	Rotate the follower arm 2 full rotations over 10 seconds. The calibration can be canceled from the Sensor Calibration page of the DTM, from the handheld, or by briefly pressing all three buttons at once.	Y R Y G
Feedback Linkage Alarm	The feedback linkage is broken or the position feedback sensor is out of range.	Fix broken linkage or recalibrate the stroke.	R R Y G
Flash CRC Error	The FLASH program memory is corrupt. This will trigger the Memory Error Warning.	Reprogram the main board with the latest firmware. If this error persists, replace the main board.	Y Y Y R
Friction High Alarm	The valve and actuator friction has passed the user set limit. High friction can cause loop oscillations, poor position control, jerky motion, or valve sticking. It can be caused by build-up from the process on the stem, trim or seat, by a failing bearing or guides in the valve and actuator, galling of the trim or stem, excessively tightened packing, linkages, or other valve or actuator mechanical issues.	Determine if the friction is significantly interfering with the valve control. If not, consider increasing the friction warning limit. Consider the following to reduce friction: Stroke the valve to clear off build-up. Clear any external mechanical obstruction, loosen the packing, clean the stem, repair or replace the actuator. Highly localized friction or very jerky travel can indicate internal galling. Repair or replace internal valve components.	R R G R
Friction High Warning	The valve and actuator friction has passed the user set limit. High friction can cause loop oscillations, poor position control, jerky motion, or valve sticking. It can be caused by build-up from the process on the stem, trim or seat, by a failing bearing or guides in the valve and actuator, galling of the trim or stem, excessively tightened packing, linkages, or other valve or actuator mechanical issues.	Determine if the friction is significantly interfering with the valve control. If not, consider increasing the friction warning limit. Consider the following to reduce friction: Stroke the valve to clear off build-up. Clear any external mechanical obstruction, loosen the packing, clean the stem, repair or replace the actuator. Highly localized friction or very jerky travel can indicate internal galling. Repair or replace internal valve components.	Y R G R
Friction Low Alarm	The friction has passed below the user set limit. Low friction is an indication of improperly loaded packing and, in severe cases, can be an indication of the process fluid leaking at the valve stem.	Check for a packing leak. Tighten or replace the valve packing.	R R G Y
Friction Low Warning	The friction has passed below the user set limit. Low friction is an indication of improperly loaded packing and, in severe cases, can be an indication of the process fluid leaking at the valve stem.	Check for packing leak. Tighten or replace the valve packing.	Y R G Y
Full Calibration in Progress	A full friction and diagnostic calibration sequence is in progress.	The calibration can be canceled from the Sensor Calibration page of the DTM, from the handheld, or by briefly pressing the QUICK-CAL button.	Y R Y G

E

Name	Description	Possible Solution	LED Color Code
Incompatible Software Alarm	The board has been reprogrammed with software that changes its communications type (FF, HART, etc.)	Reprogram the board with the correct software.	R R R B
Initializing	The positioner has powered up and is displaying a blink sequence 3 times.	Wait for 3 blink sequences to complete.	G G Y R
Inner Loop Offset Time Out	During calibration the Inner Loop Offset (ILO) value did not settle. This could result in less accurate positioning.	Repeat the stroke calibration to get a more accurate ILO value. To proceed using the less accurate ILO value, this error may be cleared by briefly pushing the QUICK-CAL button. Lowering the setting on the gain selection switch may help if the actuator is unstable during the calibration.	R G G R
Jog Calibration Set 100% Position	During a jog calibration, the unit is waiting for the user to manually adjust the valve position to the desired 100% open position.	Use the I and III buttons on the positioner to adjust the valve to the desired fully open position. Press the QUICK-CAL button to accept adjustments.	Y G G R
Jog Command Mode	The positioner has been placed in a local override mode where the valve can only be stroked using the I and III buttons. The positioner will not respond to analog or digital input commands from HART.	Control the valve using the I and III buttons. This mode may be cancelled by briefly pushing the QUICK-CAL button.	G R R Y
Local Interface Off	Control and configuration features are locked at the positioner's local interface. This is to prevent unauthorized or accidental adjustments. The buttons can still be used to view information on the LCD. The status code is only present for a short time when the user attempts to make a change through the display menu.	The DTM's Local Interface page is used to unlock the local interface, turn this feature on and off, and to set the PIN. For temporary access, a Personal Identification Number (PIN) can be entered from the positioner if an LCD is installed.	G G Y G
Low Battery Warning	The battery for the real time clock is low. The battery is designed for a 15+ year life with the positioner unpowered. The battery is not required for the positioner to control properly, but is used only to maintain the time and date upon loss of power. The time and date affect the time stamps of alarms, warnings and other events. This warning could be caused by rapidly power cycling the positioner.	The battery is not replaceable. Verify or reset the time and date. Replace the electronics assembly if the problem persists for several days.	Y R R G
No Motion Time Out	During a stroke calibration, there was no valve motion detected. Because some valves are quite large, this indicator can take up to 9 minutes to detect an error.	Check linkages and air supply to make sure the system is properly connected. If the time out occurred because the actuator is very large then simply retry the QUICK-CAL and the positioner will automatically adjust for a larger actuator by doubling the time allowed for movement. This error may be cleared by briefly pushing the QUICK-CAL.	R G Y Y

Name	Description	Possible Solution	LED Color Code
NVMEM CRC Error	The CRC test of the internal data did not pass. This may affect the function of the positioner in various ways or not at all. This will trigger the Memory Error Warning.	Error may clear with time. If error persists, cycle power and complete a QUICK-CAL. If the error still persists, perform a factory reset or replace the main circuit board.	Y Y Y R
Partial Stroke Test Failed Warning	Measured times or forces during the last partial stroke test did not pass the criteria set by the user. This may be an indication of corrosion build-up on the valve stem or in the actuator, low or restricted supply pressure, or a sticking positioner relay.	This warning will clear upon completion of a successful partial stroke test.	Y G R R
Partial Stroke Test Scheduled	The schedule established by the user shows that a partial stroke test is due.	Follow internal procedures to initiate a partial stroke test (PST). A partial stroke test will cause the valve to move suddenly and the positioner will not respond to commands while the PST is in progress. See the Partial Stroke Test page of the DTM to verify PST settings.	G Y Y R
Piezo Voltage Error	The portion of the circuit board that drives the piezo is bad, the voltage measurement circuit is bad, or piezo valve or wiring is bad. This contributes to the Main Board Electronic Failure Warning.	Replace the piezo. If alarm persists, replace the electronics assembly.	R Y R R
Piezo Voltage High Alarm	The voltage driving the piezo is above the alarm limit. This could indicate an error with the relay or the main board. The positioner may still be functioning, but have reduced performance under some circumstances.	Ensure the supply pressure is not low. If alarm persists for more than 30 minutes, the Piezo assembly is damaged. Replace the pilot relay.	R R R Y
Piezo Voltage High Warning	The voltage driving the piezo is above the warning limit. This could indicate an error with the relay or the main board. This may result from an extended period of inactivity, but in this case should not persist for more than 30 minutes when the valve is controlling. The positioner may still be functioning, but have reduced performance under some circumstances.	Ensure the supply pressure is not low. If alarm persists for more than 30 minutes, the Piezo assembly is damaged. Replace the pilot relay.	Y R R Y
Piezo Voltage Low Alarm	The voltage to the piezo is too low. The piezo may be damaged. This may prevent the proper failure position upon loss of signal/power. This condition may occur briefly on an air-to-close valve that is held for long periods of time in the closed position, or an air-to-open valve held in the open position.	Ensure the supply pressure is not low. If alarm persists for more than 30 minutes, the Piezo assembly is damaged. Replace the pilot relay.	R R R Y
Piezo Voltage Low Warning	The voltage to the piezo is too low. The piezo may be damaged. This may prevent the proper failure position upon loss of signal/power. This condition may occur briefly on an air-to-close valve that is held for long periods of time in the closed position, or an air-to-open valve held in the open position.	Ensure the supply pressure is not low. If alarm persists for more than 30 minutes, the Piezo assembly is damaged. Replace the pilot relay.	Y R R Y

E

Name	Description	Possible Solution	LED Color Code
Pneumatic Leak Warning	The positioner has detected a leak in the actuation assembly. Leakage from the actuator can cause decreased responsiveness and excessive air/gas consumption.	Repair pneumatic leaks at the tubing junctions and actuator seals. Check relay for excessive wear.	Y R Y R
Port A Out of Range	The pressure sensor for Port A is either saturated with a pressure over 10.3 bar (150 PSI) or the sensor is broken.	Check the supply pressure and the supply pressure reference. Ensure the supply pressure is less than 10.3 bar (150 PSI). Calibrate pressure sensors. Replace the electronics assembly if the condition persists.	R Y R Y
Port A Range Too Small	During a pressure sensor calibration, the range of applied pressures to port A was too small for optimum performance or the pressure sensor has failed.	Adjust the supply pressure to a higher value so the positioner can properly span the sensors, then recalibrate. If the problem persists, replace the electronic assembly.	R Y R Y
Port B Out of Range	The pressure sensor for Port B is either saturated with a pressure over 10.3 bar (150 PSI) or the sensor is broken.	Check the supply pressure and the supply pressure reference. Ensure the supply pressure is less than 10.3 bar (150 PSI). Calibrate pressure sensors. Replace the electronics assembly if the condition persists.	R Y R Y
Port B Range Too Small	During a pressure sensor calibration, the range of applied pressures to port B was too small for optimum performance or the pressure sensor has failed.	Adjust the supply pressure to a higher value so the positioner can properly span the sensors, then recalibrate. If the problem persists, replace the electronic assembly.	R Y R Y
Port C Out of Range	The pressure sensor for the relay control is either saturated with a pressure over 3.5 bar (50 PSI) or the sensor is broken.	Check the supply pressure and the supply pressure reference and the regulator adjustment. Calibrate pressure sensors. Replace the electronics assembly if the condition persists.	R Y R Y
Port C Range Too Small	During a pressure sensor calibration, the range of applied pressures to port C was too small for optimum performance or the pressure sensor has failed.	Adjust the supply pressure to a higher value so the positioner can properly span the sensors, then recalibrate. If the problem persists, replace the electronic assembly.	R Y R Y
Port R Out of Range	The pressure sensor for atmospheric reference is either saturated with a very high pressure or the sensor is broken.	Check the supply pressure and the supply pressure reference. Ensure the supply pressure is 18.8 psi. Calibrate pressure sensors. Replace the electronics assembly if the condition persists.	R Y R Y
Port R Range Too Small	During a pressure sensor calibration, the range of applied pressures to port R was too small for optimum performance or the pressure sensor has failed.	Adjust the supply pressure to a higher value so the positioner can properly span the sensors, then recalibrate. If the problem persists, replace the electronic assembly.	R Y R Y
Port S Out of Range	The supply pressure sensor (Port S) is either saturated with a very high pressure or the sensor is broken.	Check the supply pressure and the supply pressure reference. Ensure the supply pressure is less than 10.3 bar (150 PSI). Calibrate pressure sensors. Replace the electronics assembly if the condition persists.	R Y R Y

Name	Description	Possible Solution	LED Color Code
Port S Range Too Small	During a pressure sensor calibration, the range of applied pressures to the pressure sensor port (port S) was too small for optimum performance or the pressure sensor has failed.	Adjust the supply pressure to a higher value so the positioner can properly span the sensors, then recalibrate. If the problem persists, replace the electronic assembly.	R Y R Y
Position Amplitude Alarm	The amplitude of the position signal is above the alarm limit. The positioner is controlling the position of the valve with large corrections.	Verify the limits are set at an appropriate level. Adjust the selectable Gain switch to a lower setting or use the "Hi Friction" setting. Perform a QUICK-CAL which sets the gains based on valve response. Check for high friction. If the problem persists, replace the relay.	R Y O O
Position Amplitude Warning	The amplitude of the position signal is above the warning limit. The positioner is controlling the position of the valve with large corrections.	Verify the limits are set at an appropriate level. Adjust the selectable Gain switch to a lower setting or use the "Hi Friction" setting. Perform a QUICK-CAL which sets the gains based on valve response. Check for high friction. If the problem persists, replace the relay.	Y Y O O
Position Deviation Alarm	The difference between the command and the actual position has been greater than the user set limit for longer than a user set time.	Review active alarms and warnings to find root causes of this alarm. The deviation settings can be changed in the Valve Health page of the DTM.	R R R R
Position Feedback Calibration Required	Position feedback calibration required	Perform a Position Feedback Calibration. See Appendix F – Hot Keys.	R G R B
Position Frequency Alarm	The frequency of the position signal is above the alarm limit. The positioner is controlling the position of the valve with rapid corrections.	Verify the limits are set at an appropriate level. Adjust the selectable Gain switch to a lower setting or use the "Hi Friction" setting. Perform a QUICK-CAL which sets the gains based on valve response. Check for high friction. If the problem persists, replace the relay.	R Y O O
Position Frequency Warning	The frequency of the position signal is above the warning limit. The positioner is controlling the position of the valve with rapid corrections.	Verify the limits are set at an appropriate level. Adjust the selectable Gain switch to a lower setting or use the "Hi Friction" setting. Perform a QUICK-CAL which sets the gains based on valve response. Check for high friction. If the problem persists, replace the relay.	Y Y O O
Position High Limit Alert	The position has reached, or is exceeding, a user defined upper position indicator. This is similar to a limit switch indicator.	Set the limit to a higher value if more travel is needed, or adjust the command signal back in the specified range.	Y G G G
Position Low Limit Alert	The position has reached, or is exceeding a user defined lower position indicator. This is similar to a limit switch indicator.	Set the limit to a lower value if more travel is needed, or adjust the command signal back in the specified range.	Y G G G

E

Name	Description	Possible Solution	LED Color Code
Position Range Too Small	During calibration, the range of motion of the position feedback arm was too small for optimum performance.	Check for loose linkages and/or adjust the feedback pin to a position closer to the follower arm pivot to create a larger angle of rotation and recalibrate. The minimum angle of rotation should be greater than 15 degrees. Briefly pressing the QUICK-CAL button acknowledges this condition and the positioner will operate using the short stroke calibration if otherwise a good calibration.	R G G Y
Position Sensor Failure Alarm	The feedback arm may be disconnected from the valve assembly or the sensor has failed.	Check the feedback arm linkage. Recalibrate. If the problem persists return the unit for repair.	R Y R G
Power On	Power On	No issues.	G G G G
Pressure Calibration in Progress	A pressure calibration sequence is in progress.	The calibration can be canceled from the Pressure Calibration page of the DTM, or by briefly pressing the QUICK-CAL button.	Y R Y G
Pressure Calibration Required	A Factory Pressure Calibration has not been performed. Unlike a regular pressure sensor calibration, a Factory Pressure Calibration saves the calibration values to memory, making them available should a factory reset be performed. Proper pressure sensor calibration is required for proper pressure sensing and diagnostics. Calibration values from a regular pressure sensor calibration will be lost when a factory reset is performed. Typically, no pressure calibration is required with a new positioner.	Contact your Flowserve representative.	G Y Y G
Pressure Regulator Error	During the calibration the regulator pressure was too high or too low.	Call a service technician to adjust the regulator pressure to 18.8 PSI.	R G G O
Pressure Sensor Failure	One or more pressure sensors is bad. An algorithm that checks the relationship between PA, PB, and PS during operation has detected an error.	Calibrate pressure sensors. If the problem persists, replace the electronic assembly.	R Y R Y
Position Recovery Mode	Recovering from position measurement out of calibrated range.	Check valve linkage configuration, recalibrate if needed.	Y G Y G
RAM Cyclic Redundancy Check Error	The RAM data memory is corrupt. This will trigger the Memory Error Warning.	If this error persists, replace the main board.	Y Y Y O
Reference Voltage Error	The 1.25 V reference voltage is out of range. This contributes to the Main Board Electronic Failure Warning.	If alarm persists, replace the electronics assembly.	R Y R R
Reference Voltage Error	The 2.4 V reference voltage is out of range. This contributes to the Main Board Electronic Failure Warning.	If alarm persists, replace the electronics assembly.	R Y R R
Relay Calibration Adjust Clockwise	The positioner is waiting for the user to adjust the relay screw clockwise. Typically this is less than 10 degrees.	Adjust the relay screw clockwise.	G B Y O
Relay Calibration Adjust Counter-Clockwise	The positioner is waiting for the user to adjust the relay screw counter-clockwise. Typically this is less than 10 degrees.	Adjust the relay screw counter-clockwise.	R O Y B

Name	Description	Possible Solution	LED Color Code
Relay Calibration in Range	The relay calibration is complete.	Briefly press the QUICK-CAL button to accept calibration.	G G G O
Relay Calibration Settle	During a relay calibration, the pressures equalize and are compare to the supply pressure. The positioner is waiting for the pressures to be equal.	Wait until the positioner balances the pressures.	Y G B B
Relay Calibration Error	The relay is not moving far enough.	Check relay installation, alignment, o-rings, and magnet. Re-run the relay characterization.	R G O O
Relay Can't Open	The pilot relay appears to be unable to move in the open (pressurized) direction and is not responding. This could be due to a broken or out of calibration sensor, a broken piezo, stuck poppet, or a wire connection problem. This will trigger a Driver Module Alarm.	Check the internal wiring harnesses for good connections. Check the relay for sticking problems. If the positioner still does not operate replace the piezo, and/or relay assembly.	R R Y R
Relay Can't Shut	The pilot relay appears to be unable to move in the lower (depressurized) direction and is not responding. This could be due to a broken or out of calibration sensor, a broken piezo, stuck poppet, or a wire connection problem. This will trigger a Driver Module Alarm.	Check the internal wiring harnesses for good connections. Check the relay for sticking problems. If the positioner still does not operate replace the piezo, and/or relay assembly.	R R Y R
Relay Characterization in Progress	A relay calibration is in progress. The position sets the pressures equal while the user adjusts the relay adjustment screw.	Adjust the relay set screw until the pressures in port A and port B are approximately 90% of supply pressure. Then briefly press the QUICK-CAL button to end.	Y R Y G
Relay Cycles Warning	The relay cycle limit, set by the user, has been exceeded. The relay cycles indicate the activity level of the pilot relay as it maintains a valve's position. Excessive cycles can contribute to a worn relay which can lead to high air consumption.	Inspect for high air consumption and signs of wear.	Y G G Y
Relay Inner Loop Offset Out of Range Warning	The Inner Loop Offset is not close to expected value. This will trigger a Driver Module Alarm.	Check the sensor connector. Verify the relay magnet is not loose. Replace the relay. Replace the main board.	R R R O
Relay Sensor Failure	The relay sensor has failed or no magnet is detected	Check for magnet	R R Y R
Relay Travel Warning	The total accumulated relay travel (% of full relay span) set by the user has been exceeded. The relay travel indicates the activity level of the relay as it maintains a valve's position. Excessive travel can contribute to a worn pilot relay which can lead to high air consumption.	Inspect for high air consumption and signs of wear.	Y G G Y
Relay Type Unknown	Relay Type Unknown	Check the model code, update embedded software	R R Y R
Remote Mount Out of Range	During stroke calibration the remote mount ADC count was above or below the acceptable range.	Adjust remote mount POT and recalibrate.	R G B G

E

Name	Description	Possible Solution	LED Color Code
Settle Time Out	During calibration, the position feedback sensor or supply pressure (for pressure calibration) showed movement, but did not settle.	Check for loose linkages or a loose positioner sensor. Check for regulated supply pressure. This error may appear on some very small actuators during the initial calibration. Recalibrating may clear the problem, or this error may be cleared by briefly pushing the QUICK-CAL button.	R G Y G
Shunt Current Error	The shunt current is out of range. This contributes to the Main Board Electronic Failure Warning.	If alarm persists, replace the electronics assembly.	R Y R R
Shunt Voltage Error	The terminal (compliance) voltage is out of range. This contributes to the Main Board Electronic Failure Warning.	If alarm persists, replace the electronics assembly.	R Y R R
Signature or Partial Stroke Test in Progress	The positioner is in Out of Service (OOS) mode because a test or signature has been initiated. These include Step Test, Ramp Test, or Partial Stroke Test.	Signatures and tests can be defined, initiated, and cancelled through the Off-Line Diagnostics pages of the DTM.	G R G G
Soft Stop High Limit Alert	The Final Command would move the valve beyond the user set Soft Limit, but the internal software is holding the position at the limit. The function is similar to a mechanical limit stop except it is not active if the unit is un-powered.	If more travel is needed, reset the Soft Limits. If not, adjust the Final Command signal back into the specified range.	G Y G Y
Soft Stop Low Limit Alert	The Final Command would move the valve beyond the user set Soft Limit, but the internal software is holding the position at the limit. The function is similar to a mechanical limit stop except it is not active if the unit is un-powered.	If more travel is needed, reset the Soft Limits. If not, adjust the Final Command signal back into the specified range.	G Y G Y
Software Download Complete	The software download is complete.	New software is ready to be activated.	B B B G
Software Download in Progress	The system is downloading new software.	No action is required. Wait for the system to indicate that the software download is complete.	B B B B
Software Download Paused	Software download has been paused by the user.	Restart the software download.	B B B O
Software Download Waiting	The system is waiting for data during a download.	There has been some time pass where no communication has occurred during a software download. Check the signal lines.	B B B Y
Spring Unable to Fail Safe Warning	Upon loss of air supply, the valve may not move to the fail-safe position. The spring alone is not adequate to overcome the friction and process load in the system. The system is relying on pneumatic force to actuate in the direction the spring is pushing. The failsafe spring may have failed, or it was not sized properly for the application. Friction or process load may have increased.	Repair or replace actuator spring. Check for high friction. Reduce process load.	Y R R R

Name	Description	Possible Solution	LED Color Code
Squawk Mode	A user has set the positioner to flash a special sequence so that it can be visually located.	This mode is cancelled if one of the following occurs: 1) The QUICK-CAL button is briefly pressed. 2) The Squawk mode is selected again remotely. 3) More than one hour has passed since the command was issued.	G B B B
Stroke Calibration in Progress	A stroke calibration sequence is in progress.	The calibration can be canceled from the Sensor Calibration page of the DTM, from the handheld, or by briefly pressing the QUICK-CAL button.	Y R Y G
Stroke Shift	The 0% and 100% valve positions have both shifted in the same direction since the last stroke calibration. This may be related to a bent or adjusted feedback linkage, or loose positioner mounting.	Ensure the feedback linkage is not bent and the positioner is mounted securely. This notification can be cleared by briefly pressing the QUICK-CAL button.	R G R Y
Stroke Span Decrease	The 0% and 100% valve positions are closer together compared to the last stroke calibration. This could indicate debris or build up at valve seat.	Inspect valve or schedule valve for inspection. This notification can be cleared by briefly pressing the QUICK-CAL button.	R G R Y
Stroke Span Increase	The 0% and 100% valve positions are farther apart compared to the last stroke calibration. This could indicate seat wear.	Inspect valve or schedule valve for inspection. This notification can be cleared by briefly pressing the QUICK-CAL button.	R G R Y
Supply Pressure High Warning	The supply pressure is above the user set warning limit. Supply pressure that exceeds the maximum rating on the actuator can become a potential hazard.	Regulate the supply pressure at the positioner below the maximum limit recommended for your actuator. Recalibrate pressure sensors. Check the pressure sensor board connections. Replace pressure sensor board if necessary.	Y Y G R
Supply Pressure Low Alarm	The supply pressure is below the user set warning limit. Low supply pressure can cause poor valve response or positioner failure. The minimum recommended supply pressure for proper operation is 1.3 bar (19 PSI).	Regulate the supply pressure at the positioner above 1.3 bar (19 PSI). Ensure system air/gas supply is adequate. Repair kinked or restricted supply tubing. Check for pneumatic leaks in the actuator and actuator tubing. Recalibrate pressure sensors. Check the pressure sensor board connections and replace pressure sensor board if necessary.	R Y Y G
Supply Pressure Low Warning	The supply pressure is below the user set warning limit. Low supply pressure can cause poor valve response or positioner failure. The minimum recommended supply pressure for proper operation is 1.3 bar (19 PSI).	Regulate the supply pressure at the positioner above 1.3 bar (19 PSI). Ensure system air/gas supply is adequate. Repair kinked or restricted supply tubing. Check for pneumatic leaks in the actuator and actuator tubing. Recalibrate pressure sensors. Check the pressure sensor board connections and replace pressure sensor board if necessary.	Y Y Y G
Supply Voltage Error	The 1.8 V reference voltage is out of range. This contributes to the Main Board Electronic Failure Warning.	If alarm persists, replace the electronics assembly.	R Y R R

E

Name	Description	Possible Solution	LED Color Code
Supply Voltage Error	The 2.8 V reference voltage is out of range. This contributes to the Main Board Electronic Failure Warning.	If alarm persists, replace the electronics assembly.	R Y R R
Software Download Fail	During a software download, an error occurred in the communications, preventing completion.	Check communication lines. Check for enough loop current. Restart SW download function. If error persists, request a service technician to reprogram the electronics assembly.	B B B R
System Exception Warning	System has logged an internal error.	Update the firmware.	Y Y Y O
Temperature Calibration Required	Temperature Calibration Required	Contact your Flowserve representative.	R G O R
Temperature High Warning	The temperature of the internal electronics has exceeded the manufacturer set limit of 85°C (176°F). High temperature may affect performance or limit the life of the positioner.	Regulate the temperature of the positioner by shading or cooling supply gas. If the temperature reading is in error, replace the main board.	Y Y G G
Temperature Low Warning	The temperature of the internal electronics has exceeded the manufacture set limit of -40°C (-40°F). Low temperature may inhibit responsiveness and accuracy.	Regulate the temperature of the positioner. If the temperature reading is in error, replace the main circuit board.	Y Y G G
Test Mode	Test mode is active.	Power cycle to leave test mode.	G G R R
Tight Shut Off Mode	Also called MPC. The Final Command is beyond the user set limit for the tight shutoff feature and the positioner is applying full actuator pressure to close (or open) the valve. This is a normal condition for all valves when closed. The factory default setting triggers this at command signals below 1%. This indication may also occur on 3 way valves at both ends of travel if the upper Tight Shut Off value has been set.	If tight shutoff is not desired reset the tight shutoff limits or adjust the command signal inside of the specified Tight Shut Off values.	G G G Y
Valve Can't Open Alarm	Pressure has been applied (or removed) to open the valve, but the valve is not opening. This may be caused by excessive friction.	Verify adequate supply pressure is applied. Verify the feedback linkage is connected. View the friction trends if available. Consider the following: Clear any external or internal mechanical obstruction, loosen the packing, clean the stem, repair or replace the actuator, repair the valve if galling is suspected.	R Y G G
Valve Can't Shut Alarm	Pressure has been removed (or applied) to close the valve, but the valve is not closing. This may be caused by excessive friction.	Verify adequate supply pressure is applied. Verify the feedback linkage is connected. View the friction trends if available. Consider the following: Clear any external or internal mechanical obstruction, loosen the packing, clean the stem, repair or replace the actuator, repair the valve if galling is suspected.	R Y G G

Name	Description	Possible Solution	LED Color Code
Valve Closed Too Far Warning	While the valve was in use, it closed farther than it did at the last calibration by 0.5%.	Check the feedback arm linkage and ensure the valve stem connection is tight. Recalibrate the stroke. If the process cannot be interrupted a service technician may be able to adjust the calibration.	Y Y G Y
Valve Cycles Warning	The valve cycle limit has been exceeded. Each cycle represents two reversals of the direction of valve movement. The cycle counting criterion and count limit are set by the user to track the usage of the valve.	Follow routine procedures for maintenance when the limit is reached such as checking the packing tightness, and checking linkages for wear, misalignment, and tightness. After maintenance, reset the cycle accumulator.	Y G G Y
Valve Opened Too Far Warning	While the valve was in use, it opened farther than it did at the last calibration by 0.5%.	Check the feedback arm linkage and ensure the valve stem connection is tight. Recalibrate the stroke. If the process cannot be interrupted a service technician may be able to adjust the calibration.	Y Y G Y
Valve Travel Warning	The total accumulated valve travel limit has been exceeded. The travel is accumulated in both directions. The travel counting criterion and limit are set by the user to track the usage of the valve.	Follow routine procedures for maintenance when the limit is reached such as checking the packing tightness, and checking linkages for wear, misalignment, and tightness. After maintenance, reset the travel accumulator.	Y G G Y
Vent Blocked Warning	The pressure in the housing is high. This could be due to a restricted vent port, or water could have entered the housing through the electrical conduit, blocking the exhaust.	Ensure the vent port is clear from debris by removing and inspecting the vent cover or inspecting the vent tubing. Remove the housing cover and ensure no water or debris is found in the housing.	Y R R O
Voltage ADC Error	The ADC that measures reference voltage is out of range. This contributes to the Main Board Electronic Failure Warning.	If alarm persists, replace the electronics assembly.	R Y R R

APPENDIX F – HOT KEYS

Hot keys are quick button combinations to access different features without the use of the LCD menu. This table shows the key combinations and the related features.

Function	Step	Procedure	Button		
			I	II	III
Access Menu	Access the user menu.	Press I or III briefly.	Brief		Brief
	Select menu item.	Press I or III as needed.	As Needed		As Needed
	Exit the user menu.	Select the Back or Exit option in the menu and press II briefly.		Brief	
Quick Cal*	Initiate a Quick-Cal stroke calibration.*	Hold II for 3 seconds.		3s	
	(For Jog Calibration, set 100% position.)	Press II briefly.		Brief	
	Abort a Quick-Cal stroke calibration (or End Jog Cal).	Press II briefly.		Brief	
Full Cal	Initiate Diagnostic calibration.	Hold II for 6 seconds.		6s	
	Abort a Diagnostic calibration.	Press II briefly.		Brief	
Factory Reset	Set positioner to Factory Reset state.	Hold II while applying power to the positioner.		Brief	
Local Valve Control	Initiate local valve control.	Hold I and III together for 3 seconds.	3s		3s
	Move valve toward opened position.	Press I as needed.	As Needed		
	Move valve toward closed position.	Press III as needed.			As Needed
	Exit local valve control.	Press II briefly.		Brief	
Run PST	Begin Partial Stroke Test	Hold III for 3 seconds.			3s
	Abort Partial Stroke Test	Press II briefly.		Brief	
Command Source Reset (HART)	Change from digital command to analog command.	Hold I for 3 seconds.	3s		
Command Input Calibration (HART)	Initiate calibrations.	Hold I, II and III together for 3 seconds.	3s	3s	3s
	Select Command Input calibration and allow setting 0%.	Press II briefly.		Brief	
	Set 0%	Set input value and press II briefly.		Brief	
	Set 100% and complete calibration.	Set input value and press II briefly to complete calibration.		Brief	
	Abort calibration at any time.	Press I, II and III together briefly.	Brief	Brief	Brief
Analog Input Calibration (HART)	Initiate calibrations.	Hold I, II and III together for 3 seconds.	3s	3s	3s
	Select Analog Input calibration and allow setting 0%.	Press I briefly.	Brief		
	Set 0%	Set input value and press II briefly.		Brief	
	Set 100% and complete calibration.	Set input value and press II briefly to complete calibration.		Brief	
	Abort calibration at any time.	Press I, II and III together briefly.	Brief	Brief	Brief

Function	Step	Procedure	Button		
			I	II	III
Analog Output Calibration (HART)	Initiate calibrations.	Hold I, II and III together for 3 seconds.	3s	3s	3s
	Select Analog Output calibration and allow setting 100%	Press III briefly.			Brief
	Adjust output current to 100% position	Press I or III as needed.	Brief		Brief
	Store the 100% value and allow setting 0%.	Press II to move to the next step.		Brief	
	Adjust output current to 0% position.	Press I or III as needed.	Brief		Brief
	Complete calibration.	Press II to complete calibration.		Brief	
	Abort calibration at any time.	Press I, II and III together briefly.	Brief	Brief	Brief
Feedback Calibration	Initiate low level calibration functions.	Hold I, II and III together for 6 seconds.	6s	6s	6s
	Initiate feedback calibration function.	Press I briefly. Then rotate feedback arm all the way around.	Brief		
	Abort calibration at any time.	Press I, II and III together briefly.	Brief	Brief	Brief
Relay Calibration	Initiate low level calibration functions.	Hold I, II and III together for 6 seconds.	6s	6s	6s
	Initiate balance pressure function.	Press II briefly. Wait for settle blink code (YGBB) to clear.		Brief	
	If not in range (GGGO), adjust balance pressure with hex wrench.	Press I briefly. (After adjusting balance pressure.)	Brief		
	If in range (GGGO), end calibration.	Press II briefly.		Brief	
Relay Characterization	Initiate low level calibration functions.	Hold I, II and III together for 6 seconds.	6s	6s	6s
	Initiate relay characterization function.	Press III briefly.			Brief
	End calibration at any time.	Press I, II and III together briefly.	Brief	Brief	Brief
View Software Versions	View SW version.	Hold I and II together for 3 seconds. (Major SW version will be shown.)	3s	3s	
	View Minor SW version.	Press III briefly.			Brief
	View Major SW version.	Press I briefly. (You can toggle back and forth.)	Brief		
	Exit viewing SW versions.	Press II briefly.		Brief	
Adjust LCD Screen Contrast	Enter contrast adjusting mode.	Hold II and III together for 3 seconds.		3s	3s
	Select higher contrast.	Press I as needed.	As Needed		
	Select lower contrast.	Press III as needed.			As Needed
	Exit contrast adjusting mode.	Press II briefly.		Brief	
Remote Mount Toggle	Change from RM to Positioner or back.	Hold I and III together for 6 seconds.	6s		6s

*A full calibration will run if no previous full calibration has been performed since factory reset.

APPENDIX G - HOW TO ORDER

Table 26: Spare Parts Kits

Ref.	Description	Part No.
1	Gauge Cover:	
	Gauge Option Cover	361755.999.000
	No-Gauge Option Ex d Cover	361756.999.000
	No-Gauge Option IS Cover	361757.999.000
2	Gauge:	
	Nickel Plated, psi (bar/kPa)	283141.999.000
	Nickel Plated, psi (kg/cm2)	283228.999.000
	SS, psi (bar/kPa)	291846.999.000
	SS, psi (kg/cm2)	291847.999.000
	UCC Press Test Plug, 1/8" NPT	017909.999.000
3	Valve, Tank, Schrader 645A	002174.999.000
	Electronics Module:	
	HART, LCD, no Remote Mount	355153.999.000
	HART, no LCD, no Remote Mount	355156.999.000
	HART, LCD, Remote Mount (no IS)	373354.999.000
	FF, LCD, no Remote Mount (384X-)	355154.999.000
	FF, no LCD, no Remote Mount (384X-)	355157.999.000
FF, LCD, Remote Mount (no IS)	373355.999.000	
4	Piezo Assembly	218797.999.000
5	Feedback Assembly:	
	D Shaft KIT, LOGIX 38X	381225.999.000
	Reverse Spring D Shaft KIT, LOGIX 38X	603675.999.000
	NAMUR Shaft KIT LOGIX 38X	381226.999.000
	DD Shaft KIT LOGIX 38X	381227.999.000
	Reverse Spring DD Shaft KIT, LOGIX 38X	603676.999.000
	NAF Shaft KIT LOGIX 38X	381228.999.000
6	Pilot Relay Module:	
	A pilot relay module assembly includes a pilot relay, manifold, gauges, and cover with attaching hardware and gaskets. To order assemblies not listed below, contact your Flowserve representative. Have your positioner model code ready.	
	<ul style="list-style-type: none"> Aluminum manifold ¼ NPT port threads double acting standard relay 3 nickel plated gauges, psi (bar/kPa) Right side gauge orientation 	373352.999.000
<ul style="list-style-type: none"> Aluminum manifold ¼ NPT port threads double acting standard relay 3 nickel plated gauges, psi (bar/kPa) Left side gauge orientation 	373353.999.000	
7	Direct Mounting Kit:	
	Alum. IS Housing	373042.999.000
	Alum. Ex d Housing	373043.999.000

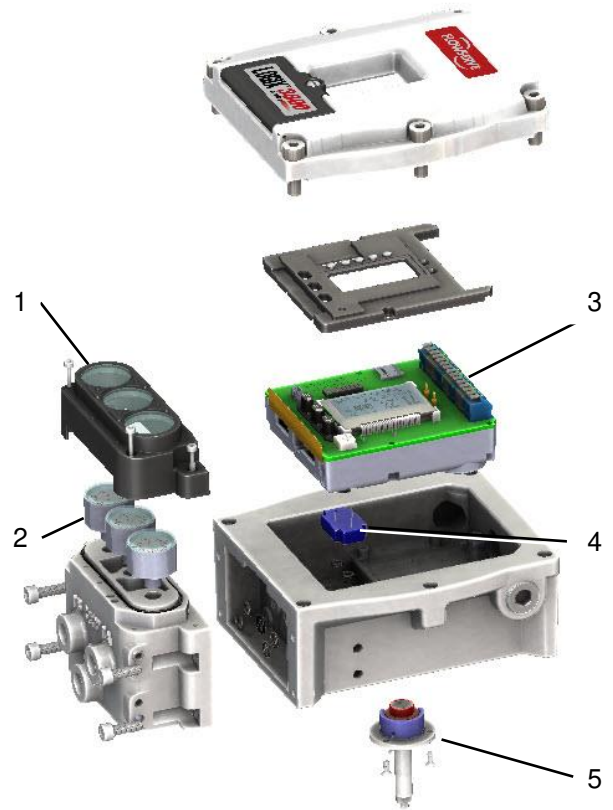

Figure 55: Spare Parts

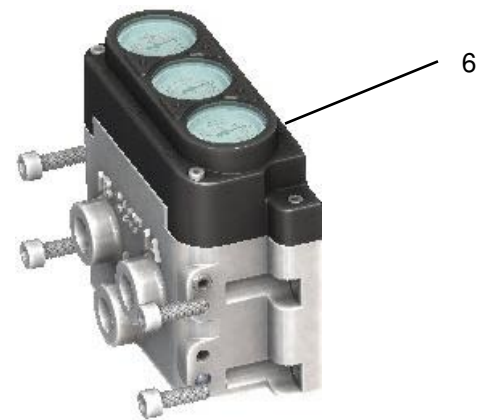

Figure 54: Pilot Relay Module

Table 27: Linear Actuator Mounting Kits (D Shaft)

Positioner Mounting Kits, Logix 3800, Valtek Linear Actuators				
Stainless Steel				
SPUD	Size 25	Size 50	Size 100/20	Size 300/400
2	380558.150.000	380442.150.000		
2.62		381232.150.000	380298.150.000	
2.88			380298.150.000	
3.38			380417.150.000	380424.150.000
4.75			380417.150.000	380424.150.000
<p>Mounting kits consist of all bracketing, bolting, stem clamps and stem clamp bolting, etc. required to mount the Logix 3800 positioner. It does not include any actuator parts nor yoke clamps and bolting.</p> <p>Contact Flowserve for assistance in selected the correct mounting kit.</p>				

Table 28: Logix 3800 Positioner Model Code

Selection	Description	Code
Base Model	Logix 3800 Series	38
Communication	HART ¹	2
	Foundation Fieldbus	4
Housing	Aluminum – IS	0
	Aluminum – Ex d	1
	Stainless Steel – Ex d	2
Certifications	General Purpose	14
	InMetro, Ex db, Ex ia,ib,ic, Ex t, Ex nA, IP66	06
	ATEX / IECEx ,Ex db, Ex ia,ib,ic, Ex t, Ex nA,Ex ec IP66 ⁵	28
	FM/US/Canada Ex Proof Class I Div 1 Gp B-D (A)Ex db, Dust Ignition Proof Class II,III Gp E-G (A)Ex tb, Intrinsically Safe Class I,II,III Div 1 Gp A-G (A)Ex ia,ib ic, Nonincendive Class I,II,III , Div 2 Gp A-G (A) Ex nA, Type 4x, IP66 ⁵	34
	IS Housing Option Only - ATEX / IECEx , Ex ia,ib,ic, Ex t, Ex nA,Ex ec IP66 FM/US/Canada , Intrinsically Safe Class I,II,III Div 1 Gp A-G (A)Ex ia,ib ic, Nonincendive Class I,II,III , Div 2 Gp A-G (A) Ex nA, Dust Ignition Proof Class II,III Gp E-G (A)Ex tb,Type 4x, IP66 ³	37
	ATEX / IECEx ,Ex db, Ex tb,FM/US/Canada Ex Proof Class I Div 1 Gp B-D (A)Ex db, Dust Ignition Proof Class II,III Gp E-G (A)Ex tb ,Type 4x, IP66 ^{5, 8}	43
	EAC TR CU Ex db, Ex ia,ib,ic, Ex t, Ex nA, IP66	44
	US Explosion Proof, Class I, Div 1, Gp A,B,C,D, Class II, Gp E,F,G, Class III CANADA Explosion Proof Class I, Div 1, Gp B,C,D, Class II, Gp E,F,G,Class III	45
	China CCC, Ex d, Ex ia, Ex ib, Ex ic, Ex iaD A20, Ex tDA21	47
Threaded Connections	Mounting: 5/16" 18 UNC, Pneumatics: 1/4" NPT, Conduit: 1/2" NPT, Vents 1/4" NPT	E
	Mounting: M8 x 1.25, Pneumatics: 1/4" NPT, Conduit: M20 x 1.5, Vents 1/4" NPT	M
	Mounting: M8 x 1.25, Pneumatics: G1/4", Conduit: M20 x 1.5, Vents G1/4"	G
Actuation Medium	Air	A
	Natural Gas	G
Relay Type	Double Acting, Standard ^{6, 7}	D
	Double Acting, Low Bleed (Natural Gas) ⁷	L
Actuator Action	Four-Way (Double Acting)	4
	Three-Way (Single Acting)	3
Pressure Gauges	No Gauges	0
	Standard Nickel Plated, psi (bar/kPa) Sealed and purged	1
	Standard Nickel Plated, psi (kg/cm2) Sealed and purged	2
	Stainless Steel, psi (bar/kPa) Sealed and purged	3
	Stainless Steel, psi (kg/cm2) Sealed and purged	4
	UCC Press Test Plug, 1/8" NPT	A
Pneumatic Output Orientation	Valve, Tank, Schrader 645A	B
	Pneumatic ports, vent and gauges oriented on the Right side	R
Diagnostics	Pneumatic ports, vent and gauges oriented on the Left side	L
	Standard Diagnostics (Standard Functionality) ²	0
Display	Pro-Diagnostics (Full Functionality)	1
	No LCD ⁴	0
Feedback Shaft	LCD	1
	No Feedback Shaft	0
	D - 316 Stainless Steel Shaft (Valtek Standard)	1
	NAMUR - 316 Stainless Steel Shaft (VDI/VDE 3845)	2
	DD - 316 Stainless Steel Shaft (Logix 3200/3400 retrofit mounting)	3
	NAF – 316 Stainless Steel Shaft	4
	DD - 316 Stainless Steel Shaft (Valtek Standard)	5
	D - 316 Stainless Steel Shaft (Reverse Spring for long stroke)	6
DD - 316 Stainless Steel Shaft (Reverse Spring for long stroke)	7	
Mounting	Standard Mounting	0
	Direct Mounting Block	D
	VDI/VDE 3847 Manifold ³	V
	Remote Mount Option ⁴	R
Special Options	No Special Options	00
	Special Options	ZZ

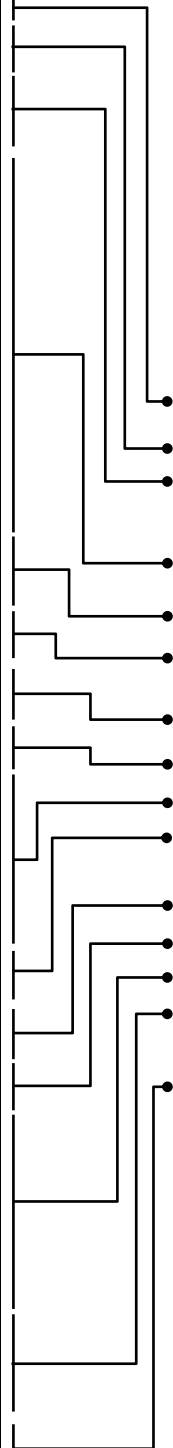

Example: 3821-28EA-D41R-0010-00

1 HART 6 standard. Can be configured as HART 7 in the field.
 2 Can be upgraded to Pro Diagnostics in the field.
 3 Available with Aluminum I.S. housing only.
 4 LCD required for Remote Mount.
 5 Only available with Ex d Housing

6 Relay is not for use with natural gas.
 7 Relay may be used for three way, single acting actuators
 8 Certification approved for Remote Mount option.

This page intentionally left blank.



Flowserve Headquarters
5215 N. O'Connor Blvd. Suite 2300
Irving, Tx. 75039
Phone: +1 972 443 6500

Flowserve Corporation
Flow Control Division
1350 N. Mt. Springs Parkway
Springville, UT 84663 USA
Phone: +1 801 489 8611
Fax: +1 801 489 3719

Flowserve Canada Inc.
9044 18th Street
Edmonton, Alberta
Canada T6P 1K6
Phone: +1 780 449 4850
Fax: +1 780 449 4850

Flowserve (Singapore) Pte Ltd.
12 Tuas Avenue 20
Republic of Singapore 638824
Phone: +65 6879 8900
Fax: +65 6862 4940

Flowserve Australia Pty Ltd.
14 Dalmore Drive
Scoresby, Victoria 3179 Australia
Phone: +61 397 593 300
Fax: +61 397 593 301

Brazil - Flowserve Ltda .
Rua Tocantins, 128
São Caetano do Sul, SP 09580-130
Brazil
Phone: +55 11 2169 6300
Fax: +55 11 2169 6313

Flowserve (Austria) Control Valves gmbH
Control Valves - Villach Operation
Kasernengasse 6
Villach, Carinthia Austria A-9500
Phone: +43 (0)4242 41181 0
Fax: +43 (0)4242 41181 50

Flowserve Netherlands
Ambachtsstraat 15
3176 PR Poortugaal
The Netherlands
Phone: +31 10 524 1050
Fax: +31 10 524 1055

Flowserve (China)
No. 35 Baiyu Road
Suzhou City, Jiangsu
China, 215021
Phone: +86 512 6255 2388

Flowserve India Controls
Plot No.4, 1 A, Road No. 8
Export Promotion Industrial Park (EPIP)
Whitefield, Bangalore – 560 066
Karnataka, India
Phone: +91 80 401 46217
Fax: +91 80 28 410286 -287

Flowserve Abahsain (Saudi Arabia) Flow Control Company Ltd.
Plot 10 & 12 Phase 4
2nd Industrial Area
Dammam Kingdom of Saudi Arabia 31952
Phone: +966 3 857 3150 X 243
Fax: +966 3 8574243

South Africa (Pty.) Ltd;
Unit N. 1
12 Director Road
Spartan, Ext 2, Kempton Park
Gauteng, South Africa
Phone: +27 11 923-7330
Fax: +27 11 974 6420

Flowserve Russia/Belorussia
2/1, Gamsonovsky Lane
115191 Moscow, Russia
Phone: +7 495 781-5977 / 79
Fax: +7 495 781-5979

Bulletin FCD LGENIM0112-07 04/21

To find your local Flowserve representative please use the Sales Support Locator System found at:

- www.flowserve.com
- digitalproductstac@flowserve.com
- Europe +43 (0) 4242 41181 999
- North America +1 801 489-2300
- Asia + (65) 6879 8900



[www.flowserve.com/en/
maximize-production-
new-logix-3800-positioner](http://www.flowserve.com/en/maximize-production-new-logix-3800-positioner)

Download 3800 Manual

(Certification information in manual may not be applicable. Valid certifications are found on positioner labels.)

Flowserve Corporation has established industry leadership in the design and manufacture of its products. When properly selected, this Flowserve product is designed to perform its intended function safely during its useful life. However, the purchaser or user of Flowserve products should be aware that Flowserve products might be used in numerous applications under a wide variety of industrial service conditions. Although Flowserve can (and often does) provide general guidelines, it cannot provide specific data and warnings for all possible applications. The purchaser/user must therefore assume the ultimate responsibility for the proper sizing and selection, installation, operation, and maintenance of Flowserve products. The purchaser/user should read and understand the Installation Operation Maintenance (IOM) instructions included with the product, and train its employees and contractors in the safe use of Flowserve products in connection with the specific application.

While the information and specifications contained in this literature are believed to be accurate, they are supplied for informative purposes only and should not be considered certified or as a guarantee of satisfactory results by reliance thereon. Nothing contained herein is to be construed as a warranty or guarantee, express or implied, regarding any matter with respect to this product. Because Flowserve is continually improving and upgrading its product design, the specifications, dimensions and information contained herein are subject to change without notice. Should any question arise concerning these provisions, the purchaser/user should contact Flowserve Corporation at any one of its worldwide operations or offices.

© 2012 Flowserve Corporation, Irving, Texas, USA. Flowserve is a registered trademark of Flowserve Corporation.

For more information about Flowserve Corporation, contact www.flowserve.com or call USA 1-800-225-6989.