

SENSiQ® Secure Mount (SSM)

Bearing unit for SENSiQ® Ring-Torsion Load Cells RTN/RTB 0.25 t ... 470 t

- Complete load cell bearing with horizontal reset function and built-in shock absorber element
- Horizontal limit stop and lift locks
- Absorbs up to 20 % of the nominal load along the horizontal axis and prevents lifting
- Legal-for-trade
- Safety without shunt forces
- High resistance to environmental conditions and chemicals
- Maintenance-free
- Pre-centered at the factory
- Design is certified according to DIN EN 1090-2 EXC 2

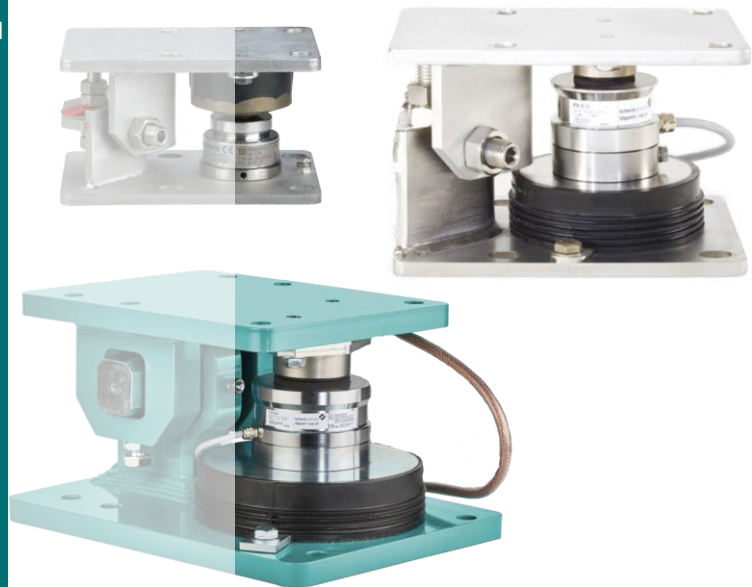

Application

The SENSiQ Secure Mount provides ideal load application to the Schenck Process SENSiQ ring torsion load cells.

It is used for as bearing unit (Secure Mount und Elastomer Mount) in industrial scales such as e.g. bin weighers, hopper scales, tank scales and mixed-mode scales and guarantee reliable and secure weighing.

Construction

The SENSiQ Secure Mount bearings consist of a load application unit, a fixed limit stop at right angles to the direction of free movement, an adjustable lift-lock and the SENSiQ Elastomer Mount that guarantees horizontal self-centering of the SENSiQ Secure Mount.

Adjustable screws are used to set the tolerance for the lift lock. The tolerance also can be checked easily in installations with little free space. The tolerance for the horizontal limit stop does not need to be adjusted.

With respect to the installation height the dimensions are compatible with the predecessor generation of VKN bearings. The bedplate on the supporting structure is considerably smaller.

Function

The weight to be measured is applied to the load cell by means of the pressure piece and transmitted to the elastomer. Depending on the model type its vertical deflection is extremely low and is proportional to the load. Any lateral forces deform the elastomer in a parallel manner. It automatically will center itself as soon as the lateral force ceases.

The horizontal limit stop restricts the freedom of movement of the bearing.

The lift lock prevents the entire structure from tipping over. A control arm is not required, which eases considerably the installation and adjustment and helps to prevent errors

Dimensions

SENSiQ Secure Mount for load cells 0.25 t ... 33 t

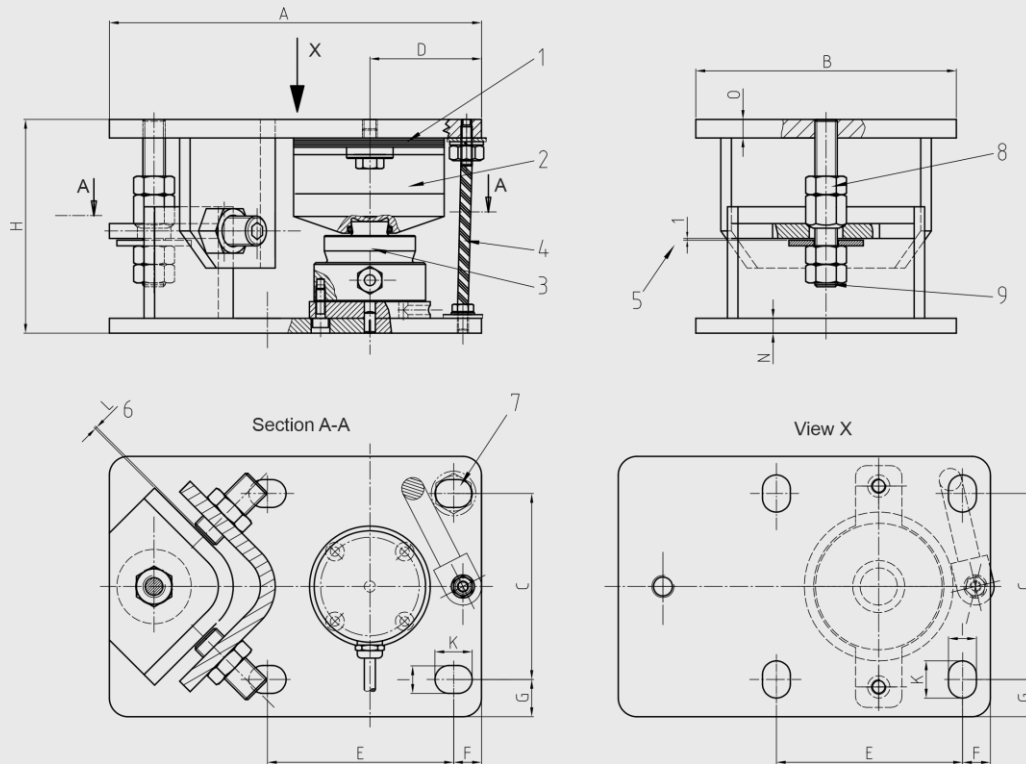

Ref.	Designation
1	Leveling plates are enclosed, suitable for adjustment of heights up to 5 mm
2	SENSiQ™ Elastomer Mount, for nominal loads of 10 t upwards the elastomer is located beneath the load cell
3	SENSiQ™ RTN/RTB
4	Grounding conductor
5	Set a 1 mm tolerance for the lift lock
6	Adjust the pendulum limit stop with play L
7	On-site fastening screw and plate, see dimension M (8x)
8	After on-site assembly screw the transport securing device nuts approx. 10 mm upwards and again lock them
9	If assembling on a workshop or on-site, the bolts should be aligned centrally to the borehole

Measurements in mm

Type	A	B	C	D	E	F	G	H*	I	K	L	M	N	O	max. horizontal force kN	max. vertical force (lifting force) kN
0.25 t ... 0.5 t RTB	195	120	90	65	90	20	15	100 ₋₅	12	12	1	M8	10	10	0.5	0.7
1 t ... 4.7 t RTN	200	140	100	60	100	15	20	115 ₋₅	15	20	1	M12	8	10	5	7
10 t ... 22 t RTN	235	180	140	90	140	20	20	155 ₋₅	18	22	1.5	M16	10	10	22	33
33 t RTN	340	250	200	135	200	35	25	197 ₋₅	22	26	2	M20	12	12	33	50

* maximum height with leveling plates

SENSiQ Secure Mount for load cells 47 t ... 470 t

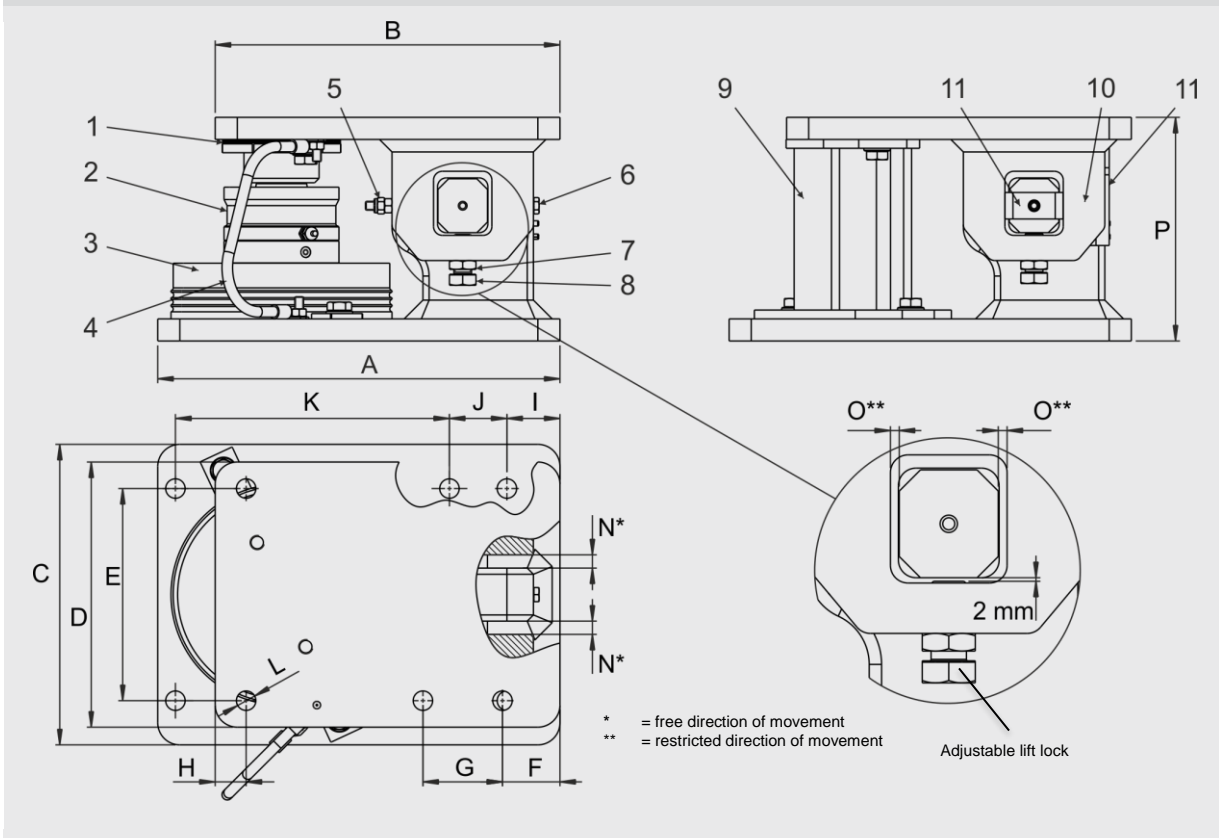

Item	Designation
1	Leveling plates are enclosed, suitable for adjustment of heights up to 5 mm
2	SENSiQ™ RTN
3	SENSiQ™ Elastomer Mount
4	Grounding conductor
5	Locknuts
6	Lock screws
7	Counternut (lift lock)
8	Adjustment screw (lift lock)
9	After assembly the transport support is replaced by items 2 and 3. Caution: The transport support has not been dimensioned for loading with the nominal load or for receiving horizontal forces.
10	Limit stop unit
11	Centering plates for transport and installation

Measurements in mm

Type	A	B	C	D	E	S	G ³	H	I ³	J ³	K ³	L ²	N	O	P ¹	Q ⁴	max. horizontal force [kN]	max. vertical force (lifting force) [kN]	max. vertical loading of the transport support [t]
47 t	455	390	340	300	240	65	90	35	60	65	310	M20	15	5	253 ₋₅	315	94	94	25
68 t	500	435	340	300	240	65	-	35	-	-	-	M20	15	5	275 ₋₅	360	136	136	25
100 t	580	520	390	340	290	45	-	45	-	-	-	M20	15	5	304 ₋₅	420	200	200	35
150 t	740	680	460	460	340	45	-	45	-	-	-	M24	20	7	395 ₋₅	520	300	300	45
220 t	850	770	480	460	380	40	-	40	-	-	-	M24	20	7	468 ₋₅	600	440	440	45
330 t	1040	910	580	460	390	70	-	70	-	-	-	M24	20	9	553 ₋₅	740	660	660	45
470 t	1240	1100	680	470	400	70	-	70	-	-	-	M24	30	10	645 ₋₅	890	940	940	45

1. Max. height with leveling plates
2. Screw and thread to be used in the connection structure, only as mounting jig
3. Throughholes (K, I, J) on bottom plate and middle holes on top plate are only available for nominal load 47 t
4. Midpoint of the load cell

The SENSiQ™ Secure Mount PLUS with maximum permissible horizontal and vertical loads of up to 40 % of the nominal load is available for greater loads of 10 t up to 330 t. Refer to data sheet BV-D2444.

Separate measures must be implemented for the horizontal limit stops and the lift lock for loads beyond these specifications.

Important information:

The connecting surfaces for the bearings must be planar and metallically bright. The difference in height in the area of the contact surface may not exceed 0.2 mm. Painted surfaces are not suited for mounting the SENSiQ Secure Mount.

A non-repeatable transmission of force may occur when raising/resettling the load cell load application elements, causing measuring errors in the scales. For this reason the load cell in the SENSiQ Secure Mount may never be completely load-free. The minimum preload should be calculated so that when in operation a permanent friction connection always connects the load cell with the pressure piece or the bearing base plate.

Arrangement of the bearings 0.25 t ... 33 t

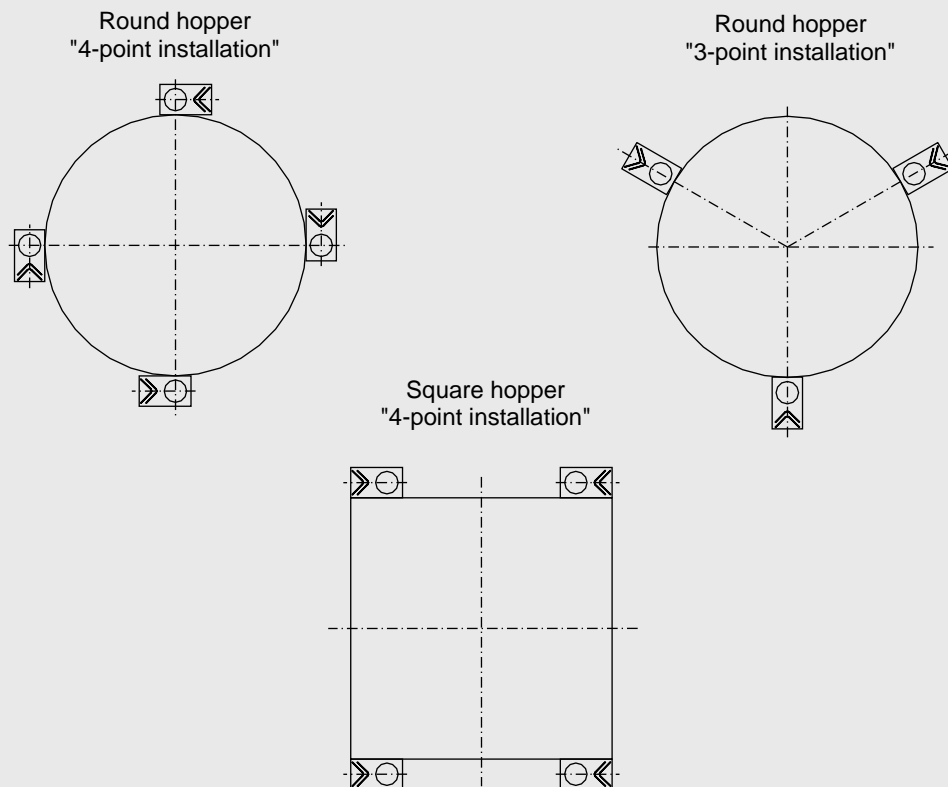

Important Notice:

The bearing arrangements shown take only weighing-related technical factors into consideration.

The operator/plant constructor must check and verify the structural safety and stability.

The direction of the temperature-dependent expansion must correspond to the free direction of movement of the SENSiQ Secure Mount.

SENSiQ Secure Mount 0.25 t ... 33 t generally are bolted to the connecting structure.

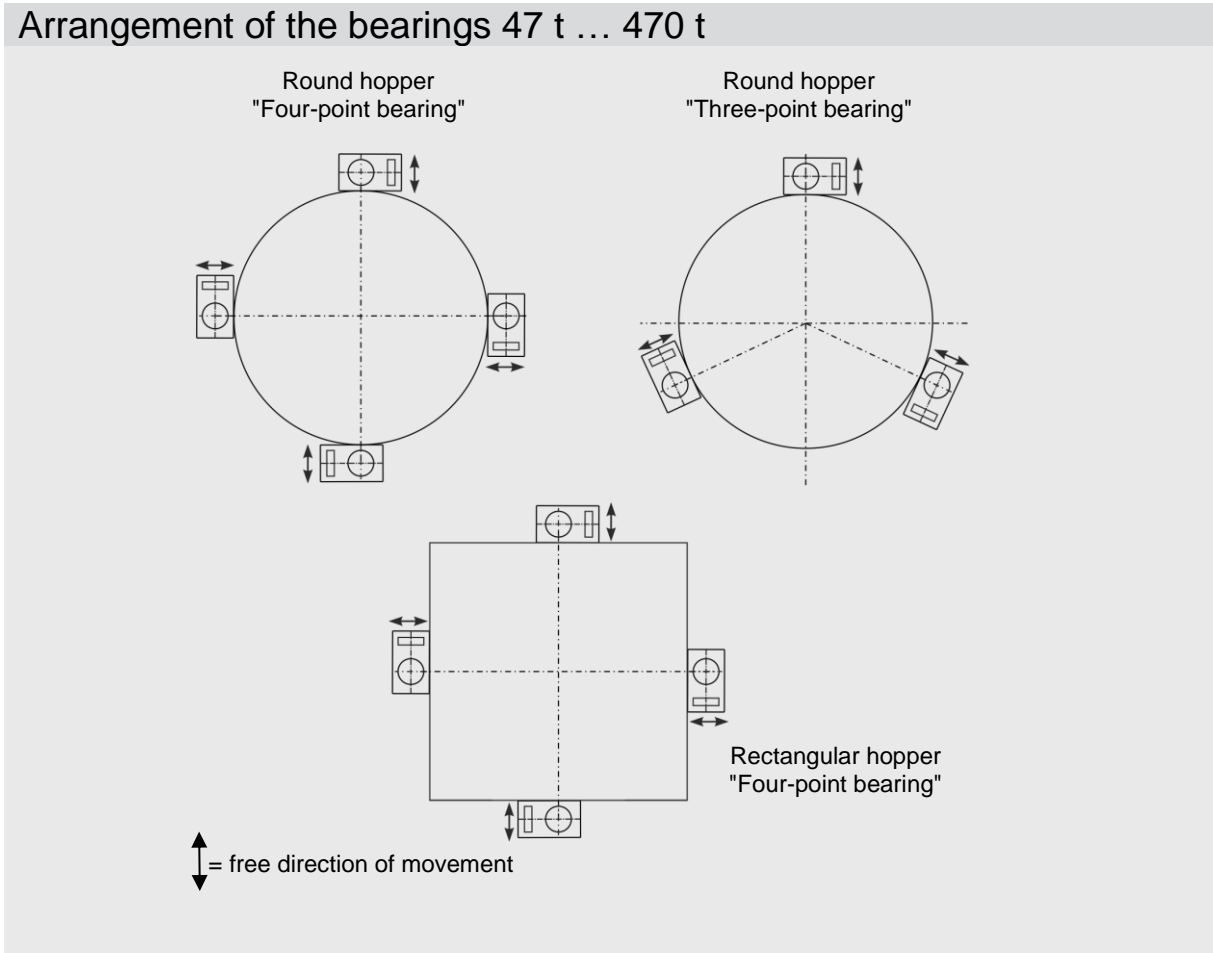

Important Notice:

The bearing arrangements shown take only weighing-related technical factors into consideration.

The operator/plant constructor must check and verify the structural safety and stability.

The direction of the temperature-dependent expansion must correspond to the free direction of movement of the SENSiQ Secure Mount.

For round hoppers the SENSiQ Secure Mount 47 t ... 470 t is designed for a minimum diameter of 3000 mm.

SENSiQ Secure Mount 47 t can be bolted or welded to the connecting structure.

SENSiQ Secure Mount 68 t ... 470 t can be affixed to the connecting structure by weld only. The holes in SSM 68 t ... 470 t are only intended for positioning and fixing during transport and welding.

Technical Data

Available nominal load	0.25 t ... 33 t		47 t ... 470 t	
Weight (including load cell)	0.25 ... 0.5 t	8.5 kg	47 t	118 kg
	1 ... 4.7 t	12.3 kg	68 t	128 kg
	10 ... 22 t	19 kg	100 t	197 kg
	33 t	42 kg	150 t	391 kg
			220 t	540 kg
			330 t	953 kg
			470 t	1412 kg
Elastomer material Optional (on request, refer also to data sheet BV-D2044 and DDP8483)	Neoprene (polychloroprene rubber) VMQ (silicone)			
Steel parts material 0.25 t ... 22 t 33 t 47 t ... 470 t	1.4301 1.0038 (S235JRG2) 1.0577+N (S355J2G4+N)			
Height compensation	up to 5 mm			
Deflection (under nominal load)	approx. 0.8 mm			
Max. permissible inclination of the substructure	0.2°			
Max. permissible angle between the upper and lower connecting structures	0.6°			
Nominal temperature range (restricted by load cell)	-10 °C ... +40 °C			
Operating temperature range (restricted by load cell and material)	-30 °C ... +80 °C			
(with special elastomer mounting and special RTN, refer to data sheets BV-D2044 and BV-D2019)	-40 °C ... +110 °C			

SENSiQ Secure Mount complete with SENSiQ Elastomer Mount, without load cell

Variants	Order Number
0.25 t	V041091.B01
0.50 t	V041092.B01
1 ... 2.2 t	D 731186.01
4.7 t	D 731186.02
10 ... 22 t	D 731353.01
33 t	D 731415.01
47 t	V654503.B01
68 t	V654503.B11
100 t	V654503.B21
150 t	V654503.B31
220 t	V654503.B41
330 t	V654503.B51
470 t	V654503.B61
Accessories	Thermal protection plate, splash water protection, weld-on plates See BV-D2228

Please contact us for further information on the SENSiQ Secure Mount and ask for the manual and the detailed planning-in drawings if needed.

Attention: SENSiQ Secure Mount (SSM) may only be used in the explosion-protected area only in Zone 2/21/22 without restriction. For zone 1 the declaration of conformity must be observed.



SENSiQ® Secure Mount PLUS
10 t ... 330 t
BV-D2444



SENSiQ® Elastomer Mount
0.25 t ... 470 t
BV-D2044



Ring torsion load cells RTN
1 t ... 470 t
BV-D2019



SENSiQ® Pendulum Mount
1 t ... 100 t
BV-D2025



SENSiQ® Fixed Mount
1 t ... 470 t
BV-D2182



SENSiQ® Fixed Mount PLUS
10 t ... 330 t
BV-D2442



<https://www.schenckprocess.com/contact>