



SMART Current Driver

HiC2031

- 1-channel isolated barrier
- 24 V DC supply (bus powered)
- Current output up to 650 Ω load
- Low power dissipation
- SIL 2 (SC 3) acc. to IEC/EN 61508



Function

This isolated barrier is used for intrinsic safety applications. It repeats the input signal from a control system to drive HART I/P converters, valve actuators, and displays located in a hazardous area. Digital signals are superimposed on the analog values at the field side or control side and are transferred bi-directionally. An open field circuit presents a high impedance to the control side to allow alarm conditions to be monitored by the control system. This device mounts on a HiC termination board.

Connection

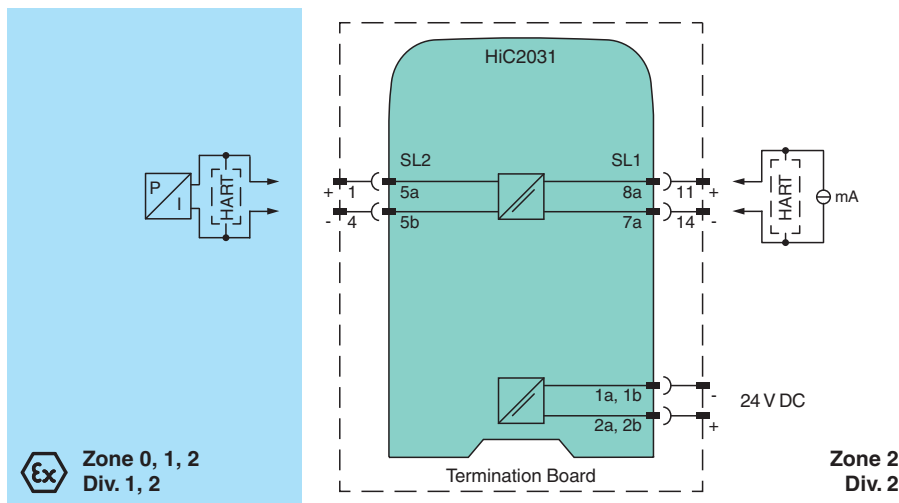

Technical Data

General specifications	
Signal type	Analog output
Functional safety related parameters	
Safety Integrity Level (SIL)	SIL 2
Systematic capability (SC)	SC 3
Supply	
Connection	SL1: 1a(-), 1b(-); 2a(+), 2b(+)
Rated voltage	U _r 19 ... 30 V DC bus powered via Termination Board

Release date: 2022-09-15 Date of issue: 2022-09-15 Filename: 321426_eng.pdf

Refer to "General Notes Relating to Pepperl+Fuchs Product Information".

Pepperl+Fuchs Group
www.pepperl-fuchs.com

USA: +1 330 486 0002
pa-info@us.pepperl-fuchs.com

Germany: +49 621 776 2222
pa-info@de.pepperl-fuchs.com

Singapore: +65 6779 9091
pa-info@sg.pepperl-fuchs.com



Technical Data

Ripple		≤ 10 %
Rated current	I_r	≤ 30 mA at 24 V
Power dissipation		≤ 600 mW at 20 mA and 500 Ω load
Power consumption		≤ 700 mW
Input		
Connection side		control side
Connection		SL1: 8a(+), 7a(-)
Input signal		4 ... 20 mA, limited to approx. 26 mA
Input voltage		open loop voltage of the control system < 30 V
Voltage drop		approx. 6 V at 20 mA
Input resistance		> 100 kΩ, with field wiring open
Output		
Connection side		field side
Connection		SL2: 5a(+), 5b(-)
Voltage		≥ 13 V at 20 mA
Current		4 ... 20 mA
Load		0 ... 650 Ω
Ripple		20 mV rms
Transfer characteristics		
Deviation		at 20 °C (68 °F), 4 ... 20 mA < 0.1 % of full scale, incl. non-linearity and hysteresis
Influence of ambient temperature		< 2 μA/K (-20 ... 70 °C (-4 ... 158 °F)); < 4 μA/K (-40 ... -20 °C (-40 ... -4 °F))
Frequency range		field side into the control side: bandwidth with 0.5 V _{pp} signal 0 ... 3 kHz (-3 dB) control side into the field side: bandwidth with 1 mA _{pp} signal 0 ... 3 kHz (-3 dB)
Rise time		10 to 90 % ≤ 10 ms
Galvanic isolation		
Input/Output		safe electrical isolation acc. to IEC/EN 60079-11, voltage peak value 375 V
Input/power supply		basic insulation according to IEC/EN 61010-1, rated insulation voltage 60 V _{eff}
Output/power supply		safe electrical isolation acc. to IEC/EN 60079-11, voltage peak value 375 V
Indicators/settings		
Display elements		LED
Labeling		space for labeling at the front
Directive conformity		
Electromagnetic compatibility		
Directive 2014/30/EU		EN 61326-1:2013 (industrial locations)
Conformity		
Electromagnetic compatibility		NE 21:2017 EN 61326-3-2:2018 For further information see system description.
Degree of protection		IEC 60529:2001
Protection against electrical shock		UL 61010-1:2012
Ambient conditions		
Ambient temperature		-40 ... 70 °C (-40 ... 158 °F)
Mechanical specifications		
Degree of protection		IP20
Mass		approx. 100 g
Dimensions		12.5 x 106 x 128 mm (0.5 x 4.2 x 5.1 inch) (W x H x D)
Mounting		on termination board
Coding		pin 1 and 3 trimmed For further information see system description.
Data for application in connection with hazardous areas		
EU-type examination certificate		CESI 06 ATEX 017
Marking		⊕ II (1)G [Ex ia Ga] IIC ⊕ II (1)D [Ex ia Da] IIIC ⊕ I (M1) [Ex ia Ma] I
Output		Ex ia

Release date: 2022-09-15 Date of issue: 2022-09-15 Filename: 321426_eng.pdf

Refer to "General Notes Relating to Pepperl+Fuchs Product Information".

Pepperl+Fuchs Group
www.pepperl-fuchs.comUSA: +1 330 486 0002
pa-info@us.pepperl-fuchs.comGermany: +49 621 776 2222
pa-info@de.pepperl-fuchs.comSingapore: +65 6779 9091
pa-info@sg.pepperl-fuchs.com
 PEPPERL+FUCHS

Technical Data

Supply			
Maximum safe voltage	U_m	250 V AC (Attention! U_m is no rated voltage.)	
Equipment		SL2: 5a(+), 5b(-)	
Voltage	U_o	25.2 V	
Current	I_o	100 mA	
Power	P_o	630 mW	
Internal capacitance	C_i	5.7 nF	
Internal inductance	L_i	negligible	
Certificate		CESI 19 ATEX 027 X	
Marking		Ⓜ II 3G Ex ec IIC T4 Gc	
Directive conformity			
Directive 2014/34/EU		EN 60079-0:2012+A11:2013 , EN 60079-11:2012 , EN 60079-7:2015	
International approvals			
FM approval			
FM certificate		FM 19 US 0122 X , FM 19 CA 0065 X	
Control drawing		116-0470 (cFMus)	
UL approval			
Control drawing		E106378	
IECEX approval			
IECEX certificate		IECEX CES 06.0002X	
IECEX marking		[Ex ia Ga] IIC , [Ex ia Da] IIIC , [Ex ia Ma] I Ex ec IIC T4 Gc	
General information			
Supplementary information		Observe the certificates, declarations of conformity, instruction manuals, and manuals where applicable. For information see www.pepperl-fuchs.com .	

Assembly

Front view

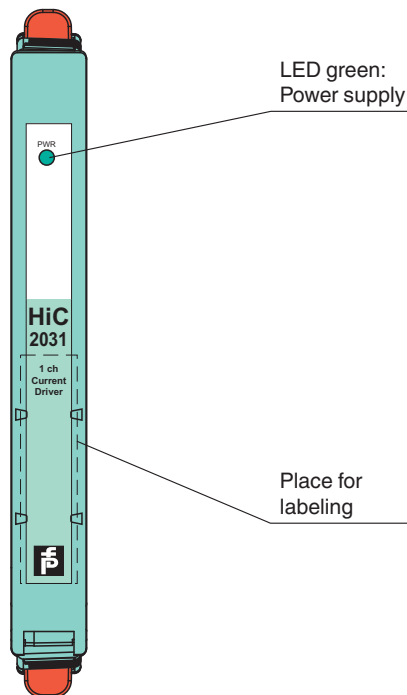

Release date: 2022-09-15 Date of issue: 2022-09-15 Filename: 321426_eng.pdf

Refer to "General Notes Relating to Pepperl+Fuchs Product Information".

Pepperl+Fuchs Group
www.pepperl-fuchs.com

USA: +1 330 486 0002
pa-info@us.pepperl-fuchs.com

Germany: +49 621 776 2222
pa-info@de.pepperl-fuchs.com

Singapore: +65 6779 9091
pa-info@sg.pepperl-fuchs.com

Safety Information



*The pins for this device are trimmed to polarize it according to its safety parameter. Do not change!
For further information see system description.*