

Gear type
flow meters
VCA / VCG



KRACHT®
FLUID TECHNOLOGY AND SYSTEMS

Contents

Construction Function General product characteristics	4
Technical data	5
Type key VCA	6
Type key VCG	7
Electrical connections Signal characteristics	8
Pressure drop charts	9 – 10
Technical drawings	11 – 13

Description

I Construction

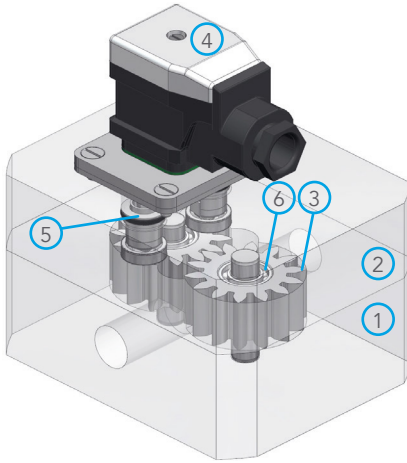

- 1 Housing
- 2 Cover
- 3 Gear
- 4 Plug
- 5 Sensor
- 6 Bearing

I Function

Consisting of two high-precision gears, the measuring unit is driven by the liquid flow based on the displacement principle. The gears run in an almost contactless manner in the measuring chamber. The bearing consists of ball and plain bearings.

The measuring principle does not cause any pressure or volume flow pulsation. Because there is no need for settling sections on the inlet and outlet side, machines/plants can be designed to be more compact. All moving parts are lubricated by the measuring medium.

The gear movement is scanned in a contactless manner by the lid-mounted sensors. During the rotation of the measuring unit by one tooth pitch, a signal is generated per sensor that corresponds to the so-called geometric tooth volume V_{Gz} .

The plug is equipped with a pre-amplifier that converts the sensor signal into a square-wave signal which serves as output signal. The dual-channel scanning facilitates a higher measuring resolution and detection of the direction of flow.

I Product characteristics

- High-precision measurements with outstanding reproducibility
- Low pressure drop
- Any flow direction
- No flow conditioners necessary
- Wide temperature range
- High working pressure
- Low noise emission
- Highly dynamic measurements
- EMV-compliant electronics
- RoHS-compliant

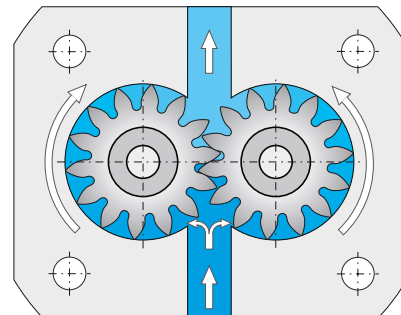

Technical data

I General characteristics VCA

Nominal sizes	0.04 · 0.1 · 0.2 · 2 · 5
Type of connection	plate mounting (P) / pipe connection (R)
Mounting position	any
Flow direction	any
Typical measurement accuracy	+ 1.0% from a viscosity of 20 mm ² /s
Maximum permissible pressure loss	16 bar (VCA 0.2 = 10 bar)
Ambient temperature	-10 ... 80°C
Media temperature	-10 ... 80°C
Viscosity	... 4 000 mm ² /s
Sound pressure level	... 60 dB(A)

I Materials VCA

Housing and cover	aluminium
Gears	stainless steel / steel
Bearing	ball bearing, plastic plain bearing, multi-layer plain bearing
Seals	FKM

I General characteristics VCG

Nominal size	2
Type of connection	plate mounting (P)
Mounting position	any
Flow direction	any
Typical measurement accuracy	+ 2.5% from a viscosity of 20 mm ² /s
Maximum permissible pressure loss	16 bar
Ambient temperature	-10 ... 80°C
Media temperature	-15 ... 120°C
Viscosity	... 4 000 mm ² /s
Sound pressure level	... 60 dB(A)

I Materials VCG

Housing and cover	spheroidal cast iron
Gears	steel
Bearing	multi-layer plain bearing
Seals	FKM

I Overview VCA/VCG operating characteristics

Nominal size	geom. tooth volume V _{gz}	Measuring range	Measuring unit starting at	Resolution	Maximum pressure	Weight
	cm ³	l/min	l/min	pulse/l	bar	kg
VCA 0.04	0.040	0.02 ... 4	0.004 (ν = 20 mm ² /s)	25,000.00	240	0.5
VCA 0.1	0.100	0.08 ... 10	0.008 (ν = 20 mm ² /s)	10,000.00	240	0.6
VCA 0.2	0.200	0.25 ... 10	0.04 (ν = 100 mm ² /s)	5,000.00	200	0.6
VCA 2	2.000	1.00 ... 65	0.04 (ν = 100 mm ² /s)	500.00	200	1.9
VCG 2	2.000	1.00 ... 65	0.12 (ν = 100 mm ² /s)	500.00	350	5.0
VCA 5	5.222	1.00 ... 200	0.1 (ν = 20 mm ² /s)	191.50	100	6.0

I Available versions

Nominal size	Bearing			Material			Seal	Type of connection	
	Ball bearing	Plastic plain bearing	Multi-layer plain bearing	Housing spheroidal cast iron / gears steel	Housing aluminium / gears stainless steel	Housing aluminium / gears steel	FKM	Plate mounting	Pipe connection
VCA 0.04	•	–	–	–	•	–	•	–	•
VCA 0.1	•	–	–	–	–	•	•	–	•
VCA 0.2	–	•	–	–	–	•	•	–	•
VCA 2	–	•	•	–	•	•	•	•	•
VCG 2	–	•	•	•	•	•	•	–	•
VCA 5	•	–	–	–	–	•	•	–	•

Type key VCA

Example

VCA	0.2	K	4	F	4	P	2	S	H
1	2	3	4	5	6	7	8	9	10

1 Product	
2 Nominal size	
0.04	
0.1	
0.2	
2	
5	
3 Bearing	
K	ball bearing
U	plastic plain bearing
M	multi-layer plain bearing
4 Material	
4	housing aluminium / gears stainless steel
5	housing aluminium / gears steel
5 Sealing	
F	FKM
6 Surface	
3	without coating
4	hard-coated
5	anodized (decorative)
7 Connection type	
P	Plate mounting (only nominal sizes 0.2 and 2)
R	Pipe connection
8 Sensors	
1	1 sensor
2	2 sensors
3	without sensors
4	2 sensors, vibration-proof/condensation-proof
9 Electronic versions (pre-amplifier)	
S	Standard
V	without pre-amplifier
10 Electric connection (plug and pre-amplifier housing)	
H	appliance socket (Hirschmann) standard
M	appliance socket (Hirschmann) with M12x1 4-pole connection
V	without

Type key VCG

Example

VCG	2	M	1	F	1	P	2	S	H
1	2	3	4	5	6	7	8	9	10

1 Product	
2 Nominal size	
2	
3 Bearing	
M	multi-layer plain bearing
4 Material	
1	housing spheroidal cast iron GJS-400 / gears steel
5 Sealing	
F	FKM
6 Surface	
1	standard coating
3	without coating
7 Connection type	
P	plate mounting
8 Sensors	
1	1 sensor
2	2 sensors
9 Electronic versions (pre-amplifier)	
S	Standard
V	without pre-amplifier
10 Electric connection (plug and pre-amplifier housing)	
H	appliance socket (Hirschmann) standard
M	appliance socket (Hirschmann) with M12x1 4-pole connection
V	without

Electronics

I Electrical connections

Electrical connection VCA – single-channel

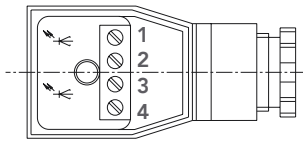

1: U _B (brown)
2: Channel 1 (green)
3: not assigned
4: 0 Volt (white)

Electrical connection VCA 0.2/VCG 2 – dual-channel

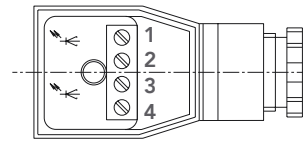

1: U _B (brown)
2: Channel 1 (green)
3: Channel 2 (yellow)
4: 0 Volt (white)

I Electrical characteristics

Number of measuring channels	single-channel: VCA 0.04 · 0.1 · 0.2 · 2 · 5 dual-channel: VCA 0.2 · VCG 2
Working voltage U _B	12 ... 30 V DC reverse polarity protected
Pulse amplitude U _A	≥ 0.8 U _B
Pulse shape with symmetrical output signal	Square duty factor/channel 1:1 +/- 15%
Signal output	PNP / NPN
Pulse offset between the two channels (2 sensors)	90° ± 30°
Power requirement P _{B max}	0.9 W
Output power / channel P _{A max}	0.3 W short circuit-protected
Protection rating	IP 65

I Signal characteristics

The pre-amplifier-generated square-wave signal enables application-specific resolutions. Standard resolution means that the electronics will process one pulse from a channel/sensor per cycle time (rising signal edge in channel I). In contrast, the 4-fold evaluation uses the maximal pulse rate per cycle time, allowing for a resolution that is four times as high as in the standard evaluation. All characteristics of the signal (rising and falling signal edge of both sensors/channels) are exploited in the evaluation.

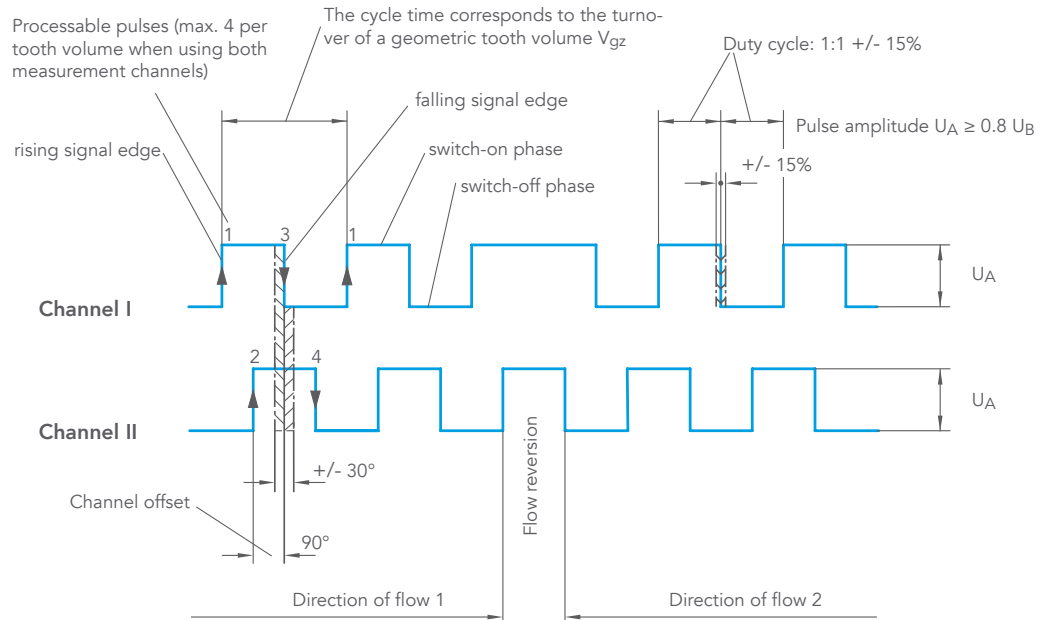

Pressure drop Parameter: Viscosity in mm²/s

I VCA 0.04 ... 0.2

VCA 0.04

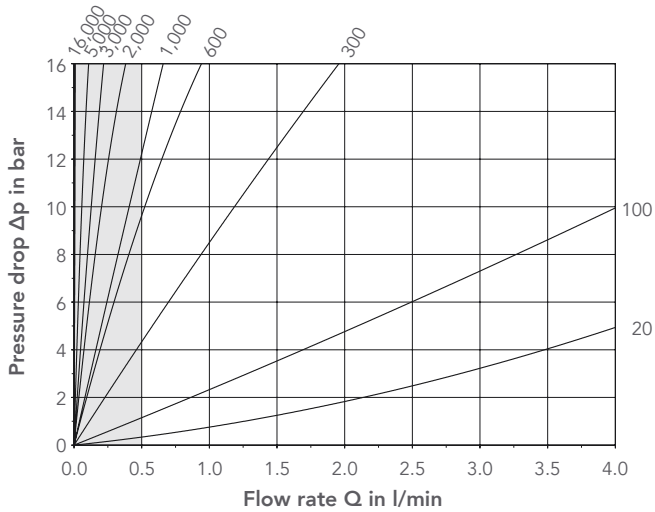

VCA 0.04 (section)

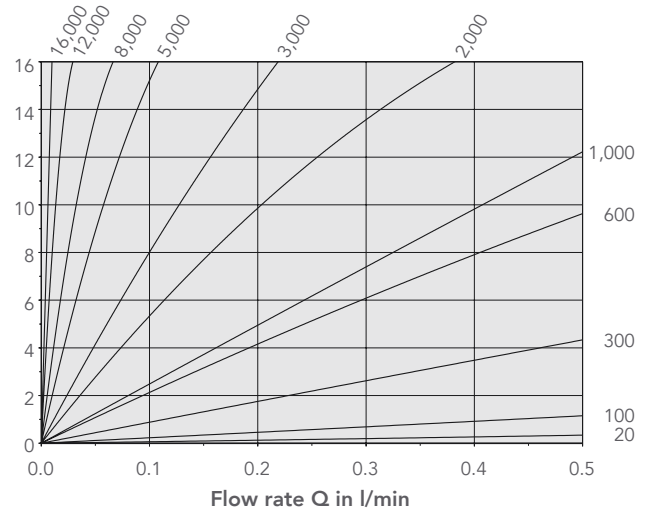

VCA 0.1

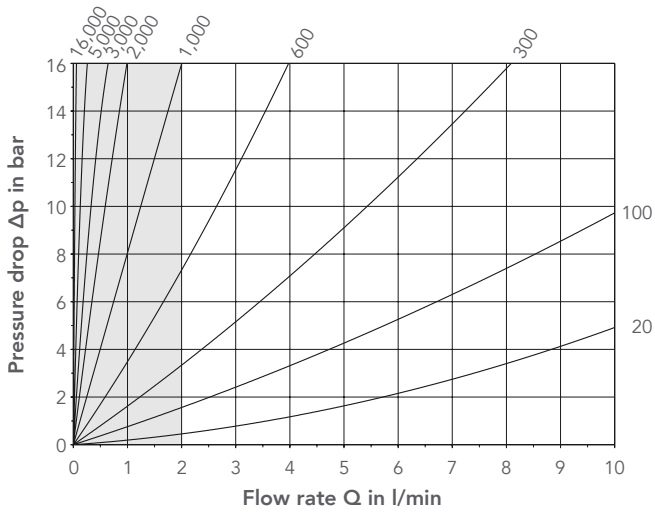

VCA 0.1 (section)

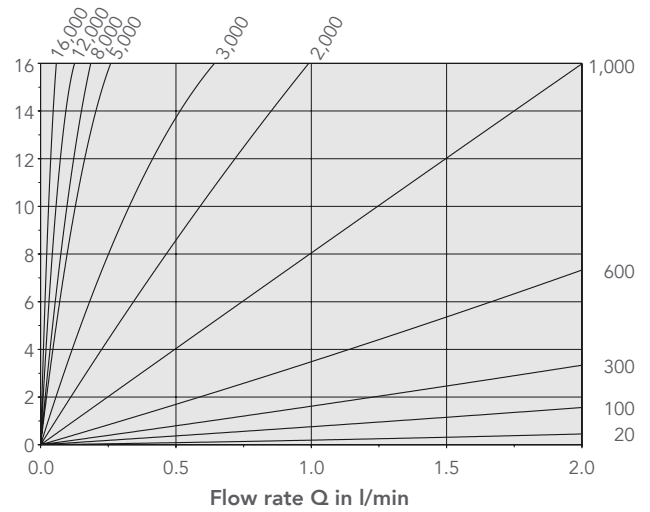

VCA 0.2

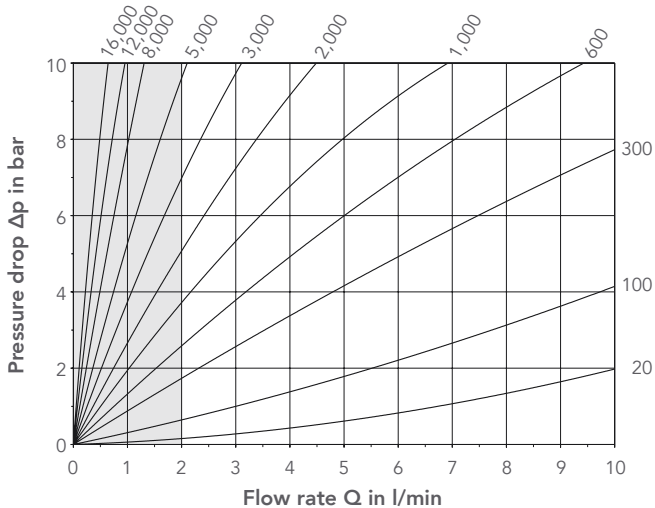

VCA 0.2 (section)

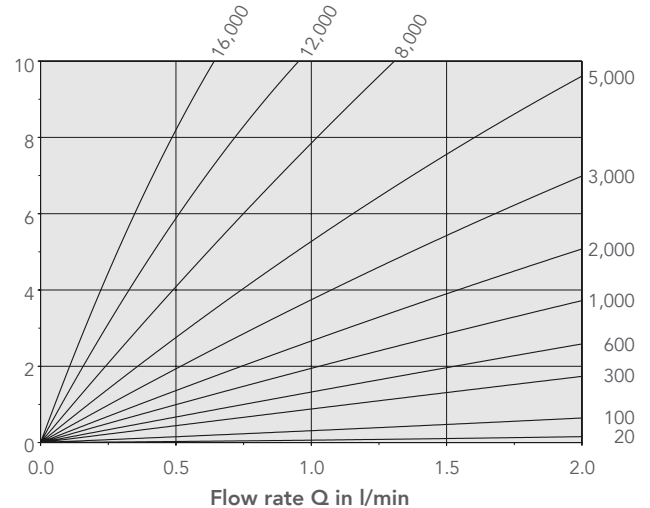

Pressure drop Parameter: Viscosity in mm²/s

I VCA/VCG 2 and VCA 5

VCA/VCG 2

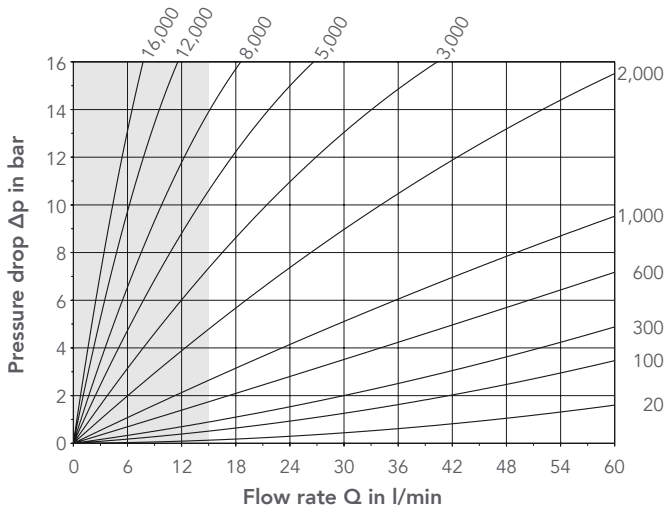

VCA/VCG 2 (section)

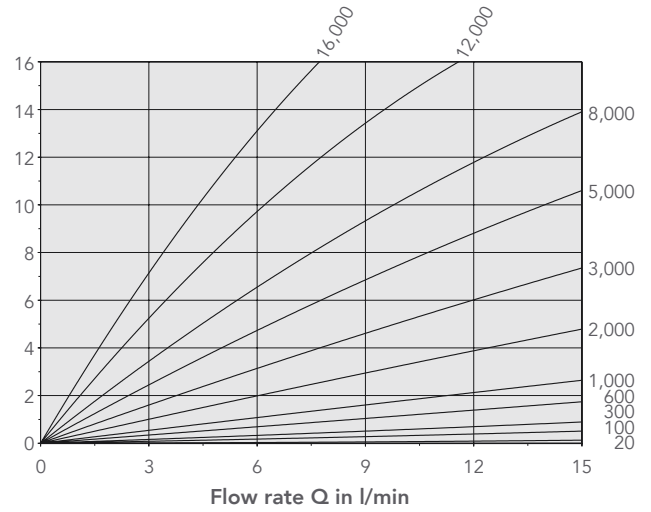

VCA 5

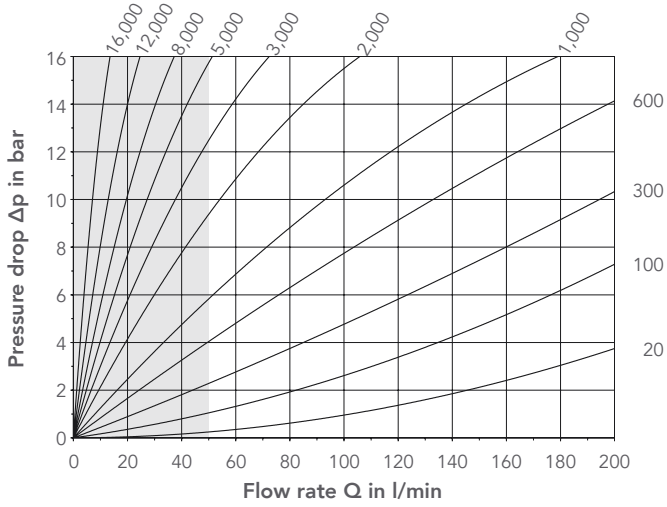

VCA 5 (section)

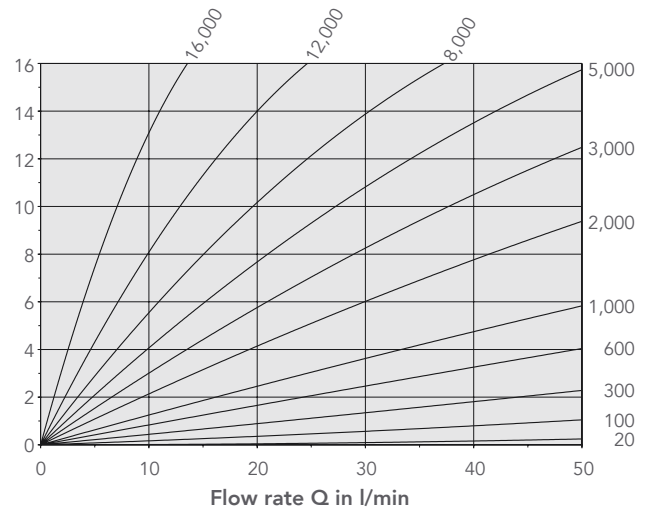

Dimensions

I VCA 0.04

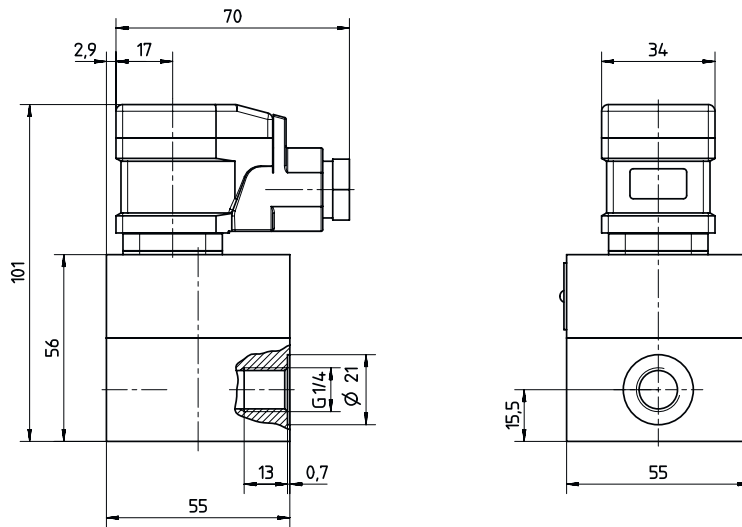

I VCA 0.1

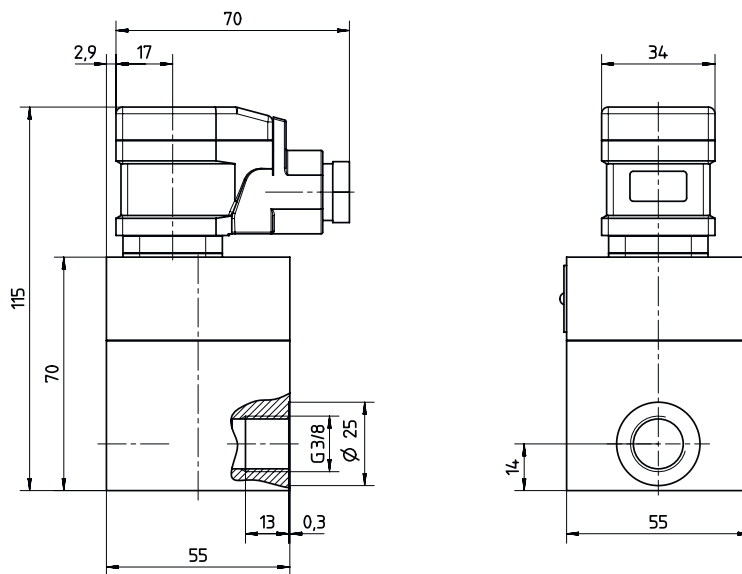

I VCA 0.2

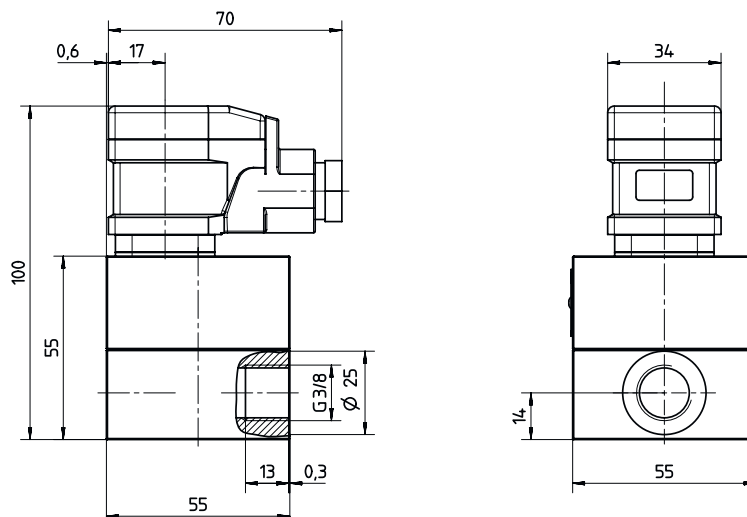

Dimensions

I VCA 2 – pipe connection

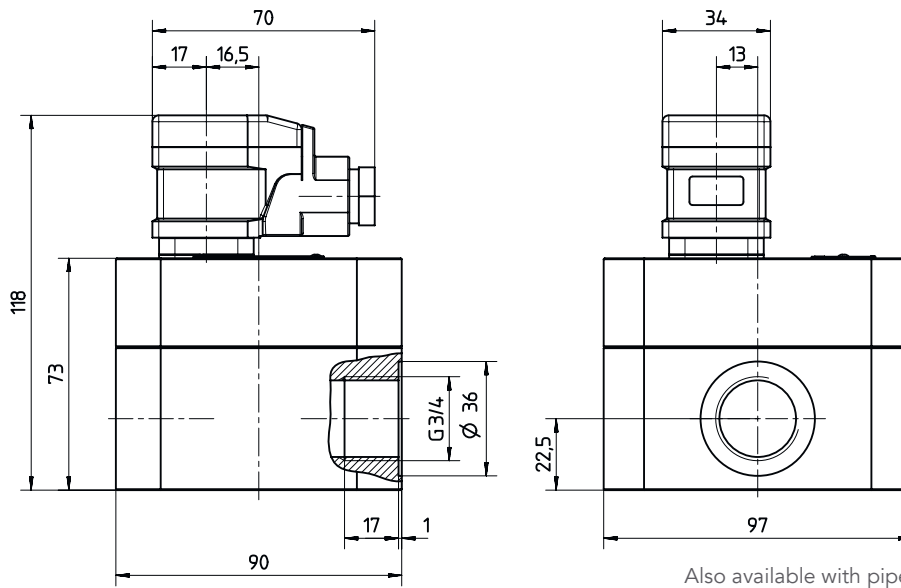

Also available with pipe connection dimension G1.

I VCA 2 – plate mounting

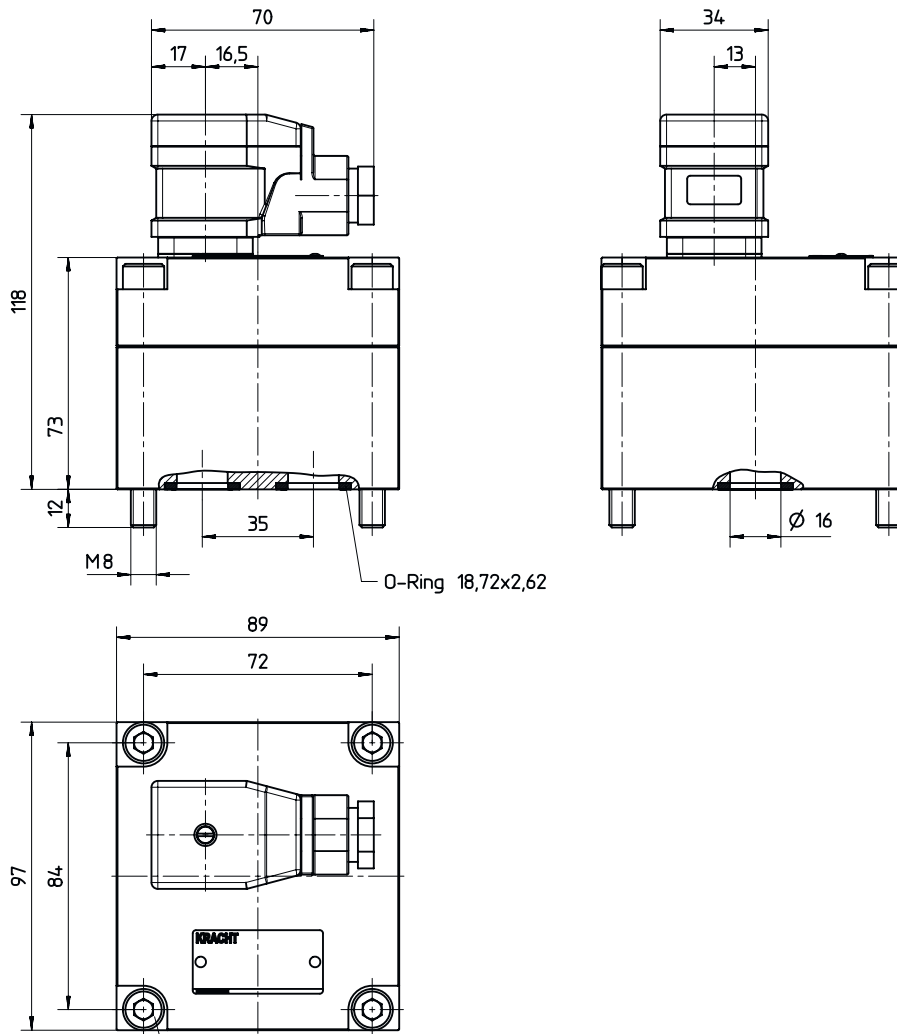

Tightening torque MA=13 Nm

Dimensions in mm

Dimensions

I VCG 2

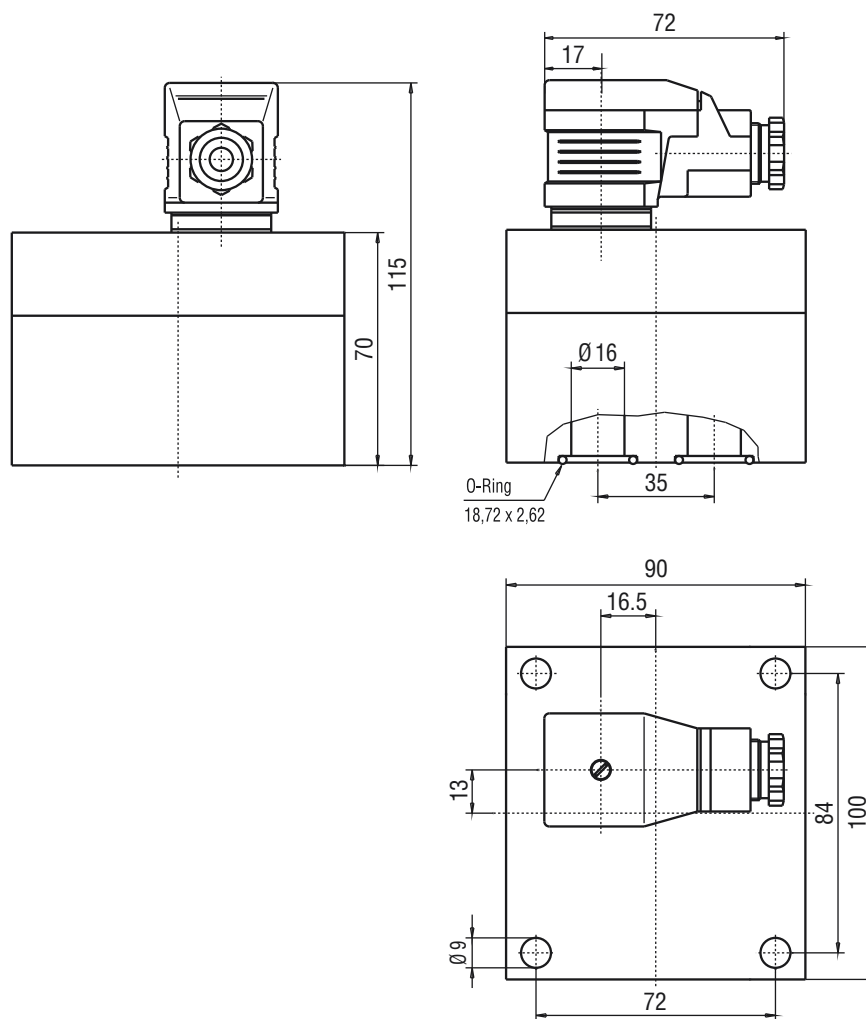

I VCA 5

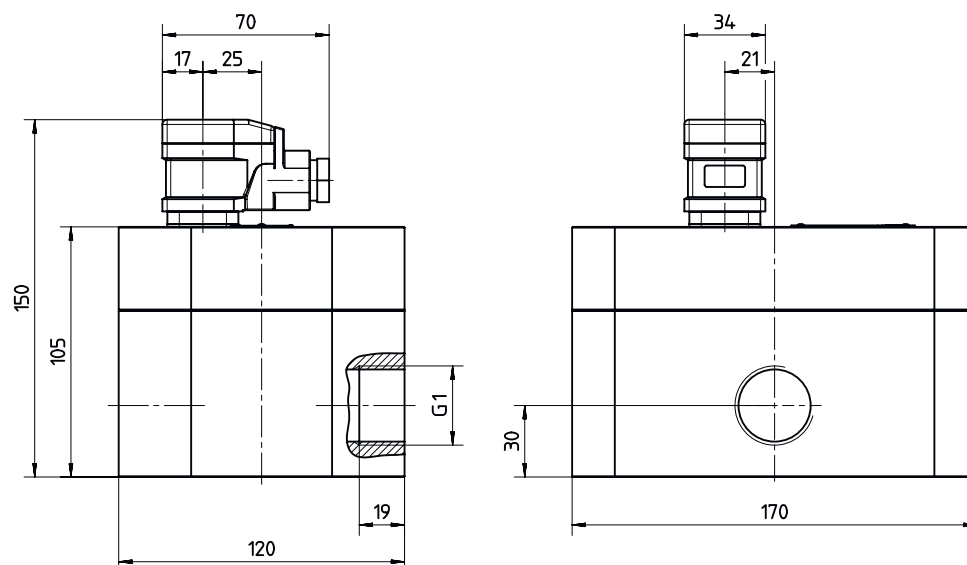

Notes

Notes

KRACHT[®]

KRACHT GmbH · Gewerbestraße 20 · 58791 Werdohl, Germany
Phone +49 2392 935 0 · E-Mail info@kracht.eu · Web www.kracht.eu