

DFM for SLM280.124-BODY

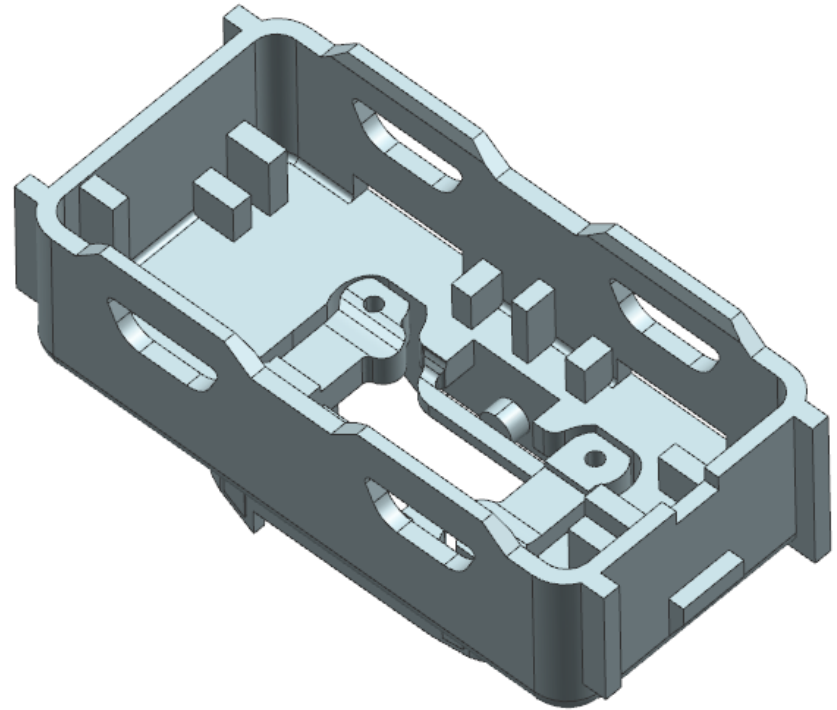

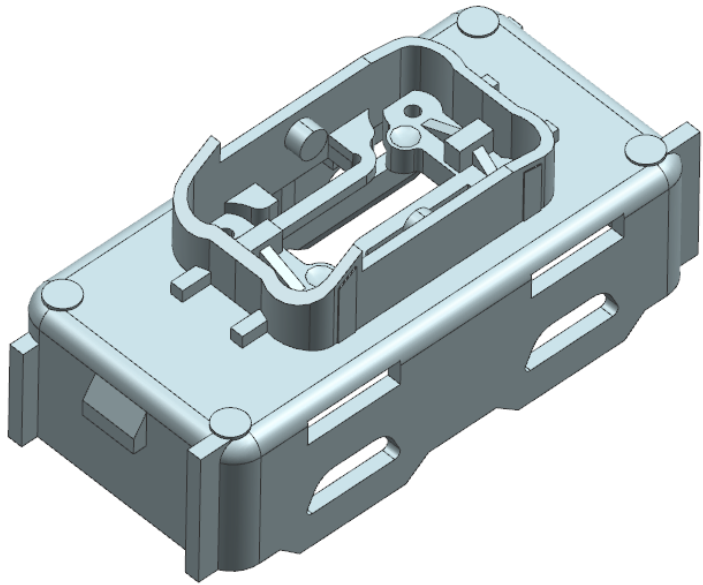
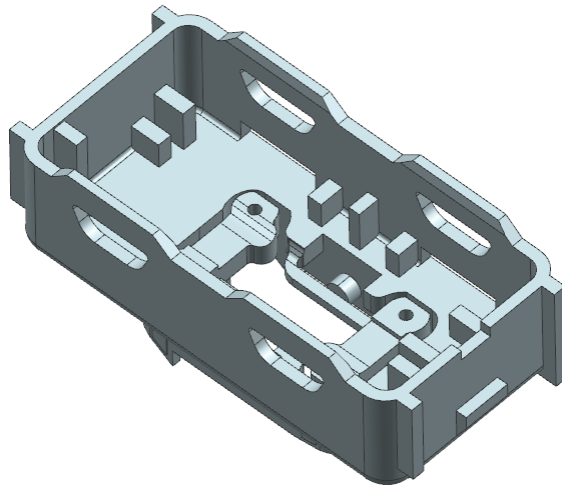
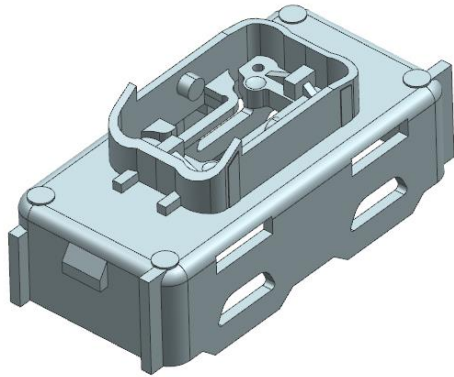

INDEX	Part Information	
1	Customer:	/
2	Project:	/SLM280.124
3	Part Name :	BODY
4	Part No :	
5	Material :	PC+ABS(Black)
6	Material No :	/
7	Shrinkage :	1.006 PLEASE CONFIRM
8	MaxSize :(mm)	46X21.8X19.24mm
9	Weight :(g)	4g
10	Cave :	1*2
11	Gate :	Sub gate
12	Insert Material :	1.2344
13	Undercut :	
14	Appearance:	
15	Mold Size:(mm)	
16	Machine: (T)	/
17	Texture:	/
18	Cycle Time :	/

01 Parting Line

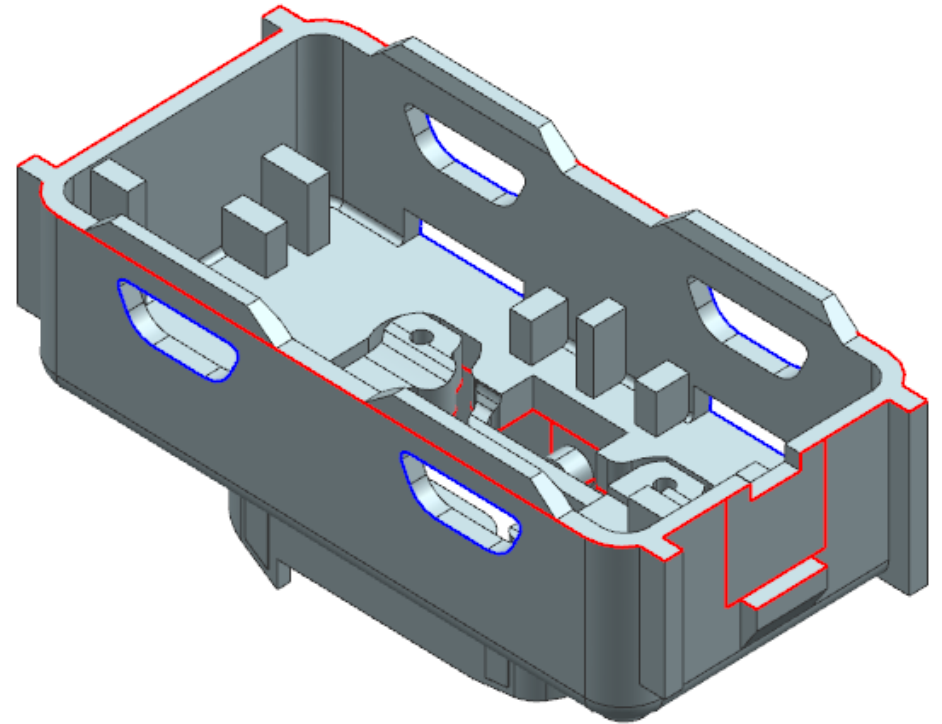
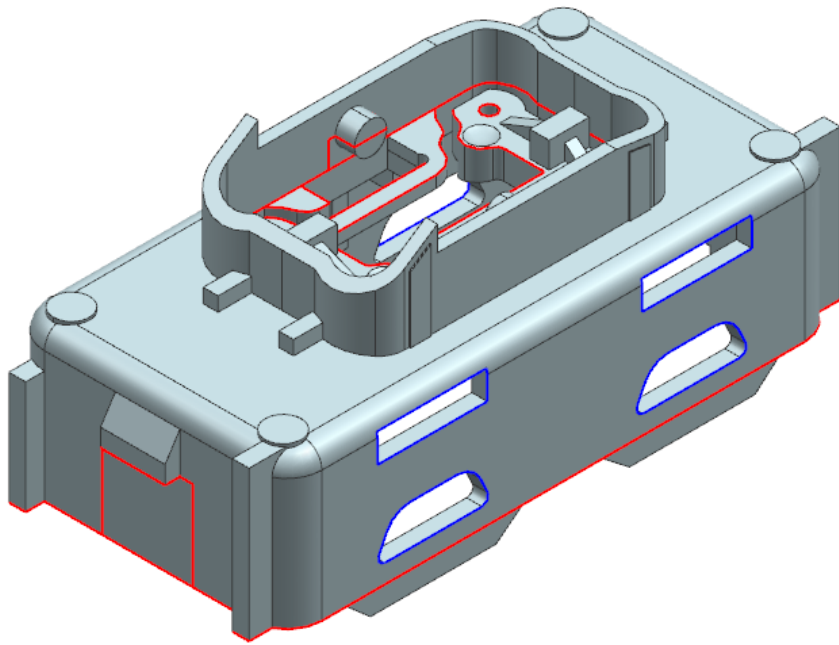

The red lines are the PL line
please confirm.

The Blue lines are the Slider
line please confirm.

02 Layout

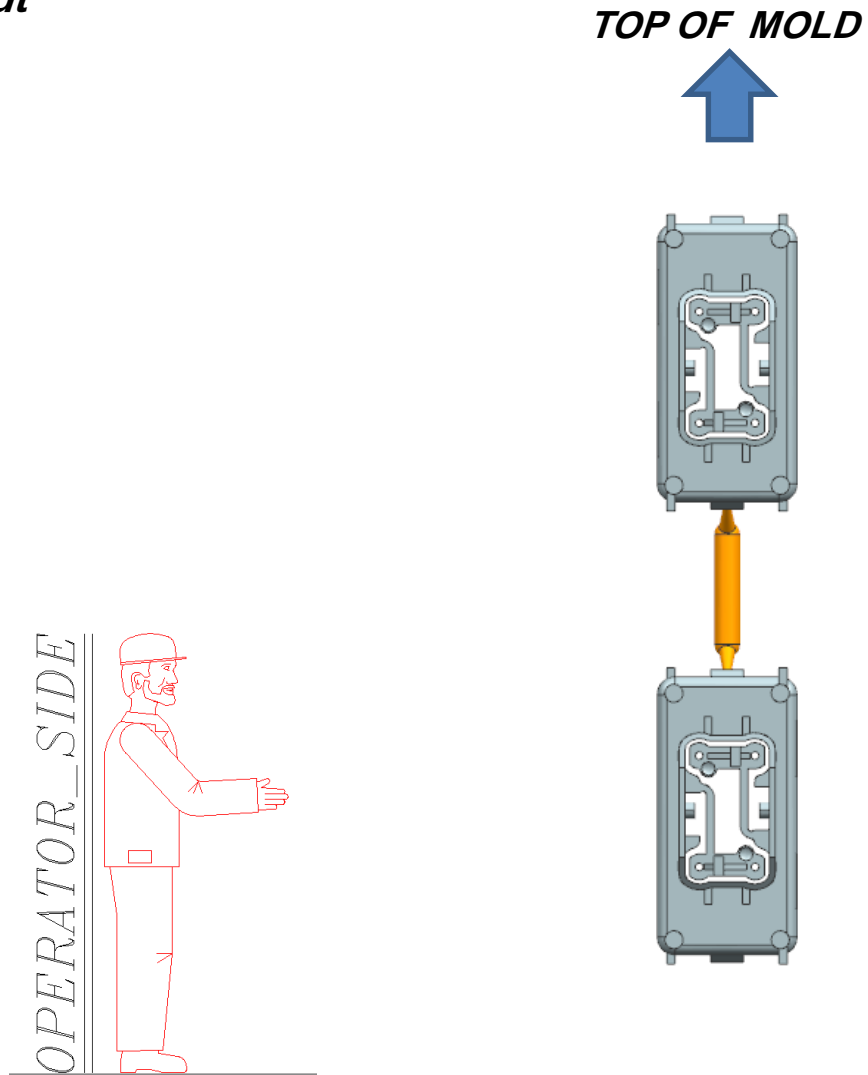

03 Gate

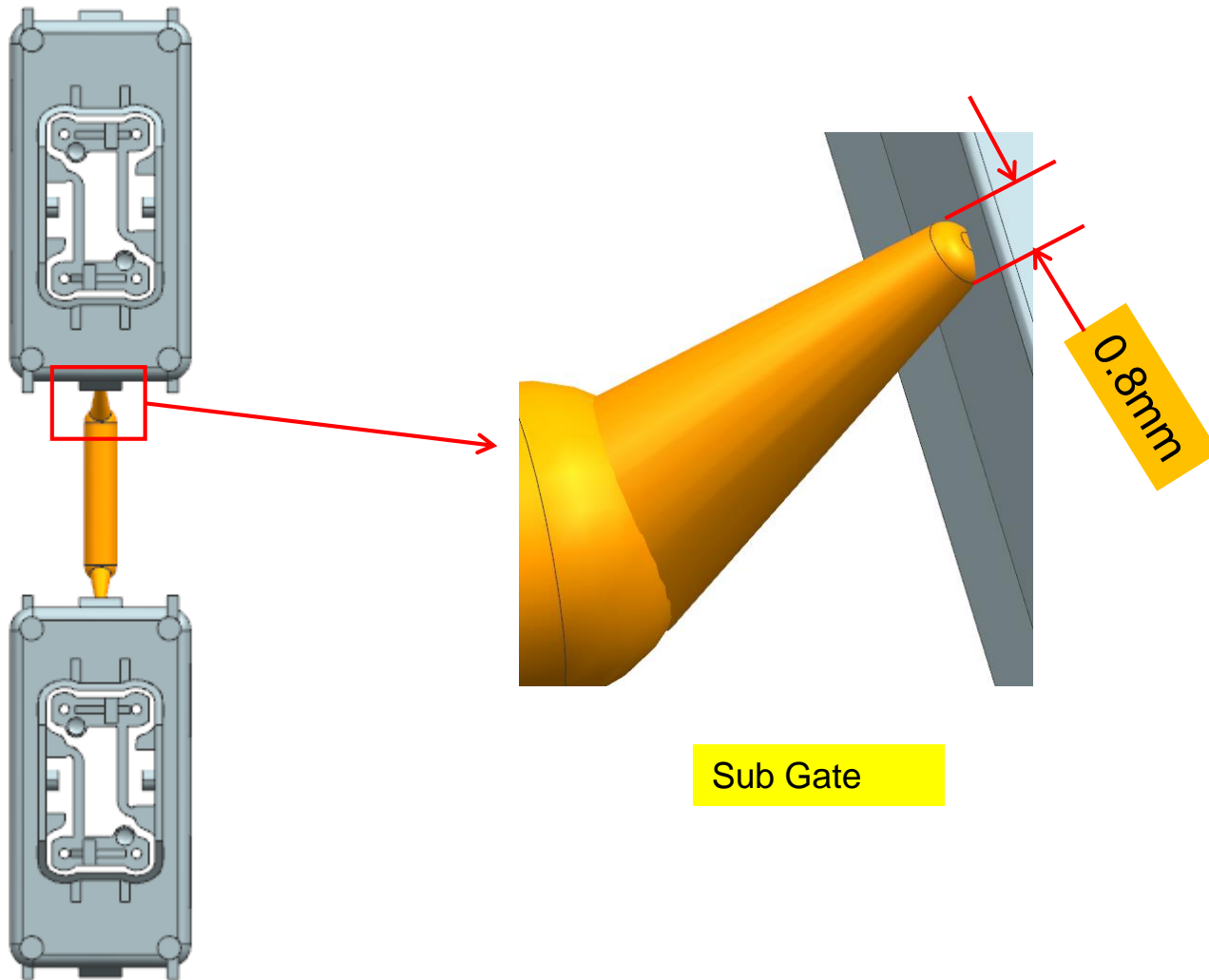

04 Ejector

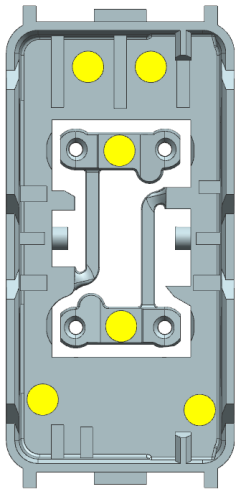

 Ejector Pin
Ø3mm

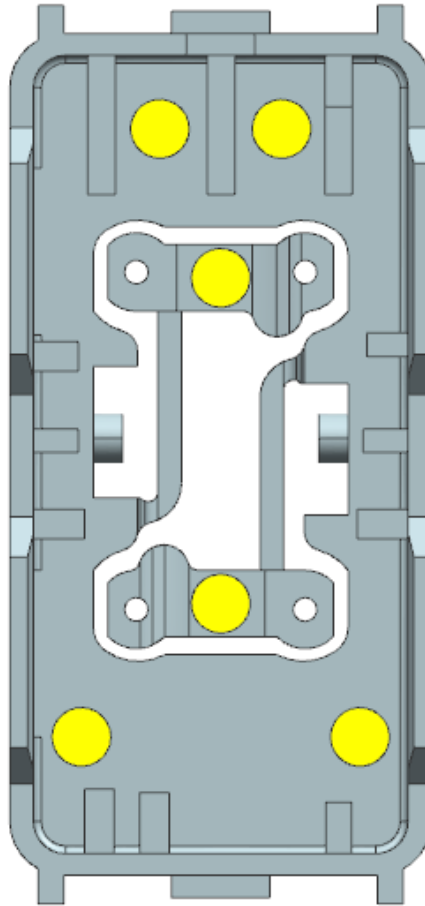

05 Mold Action

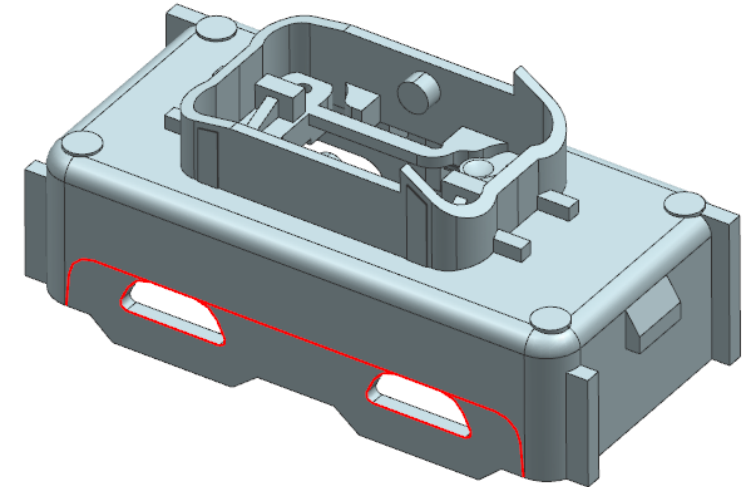
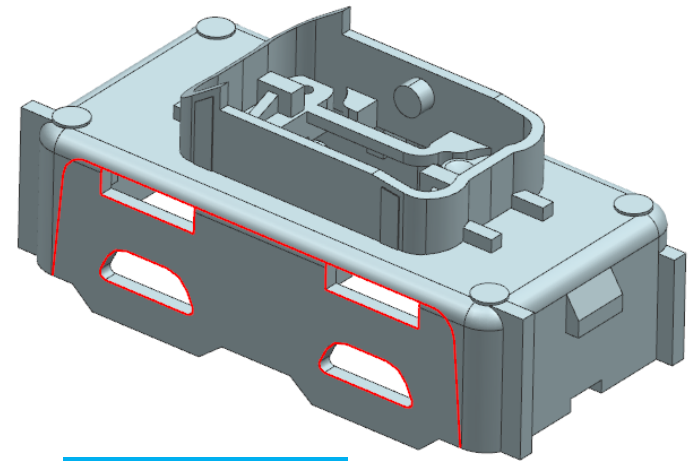
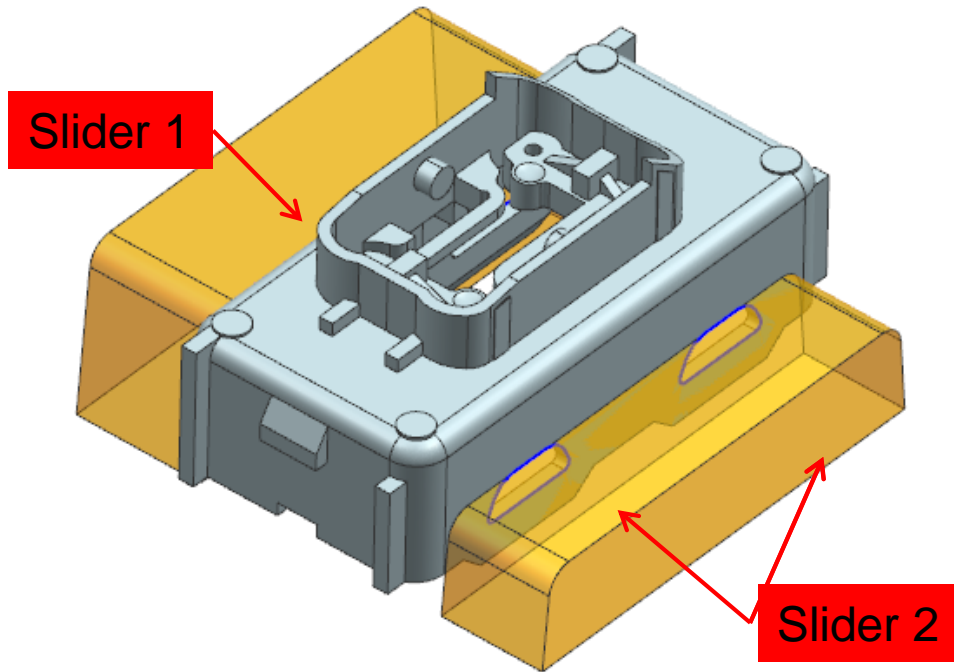

06 Degree Draft

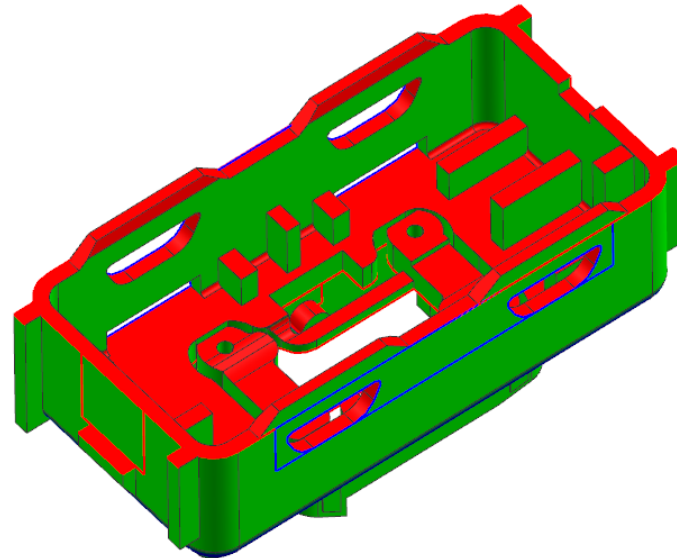
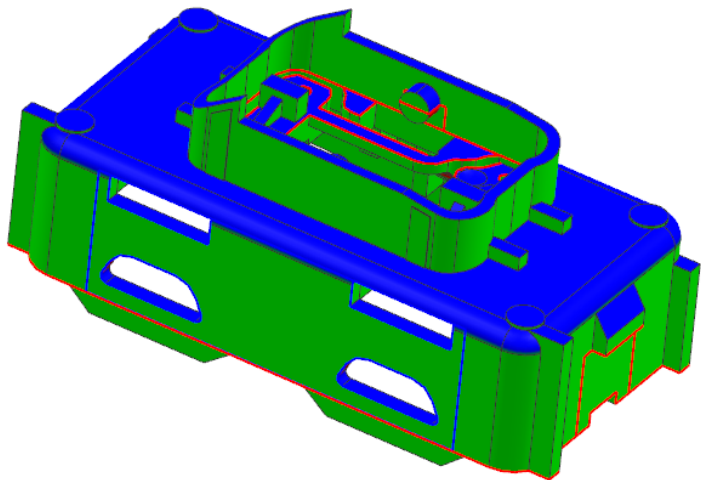
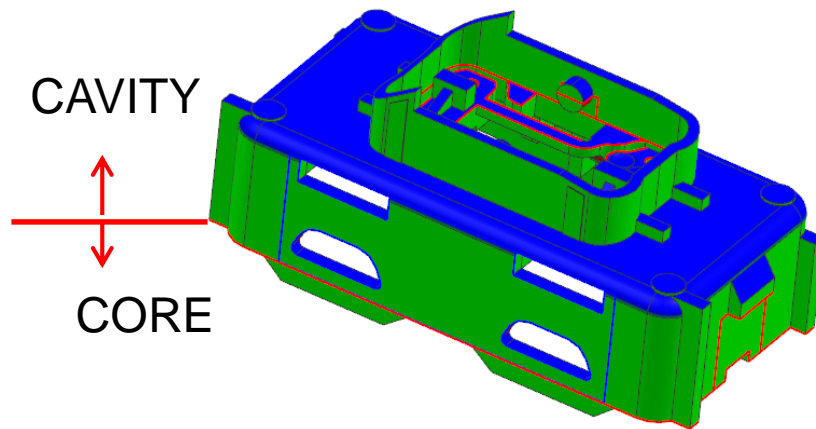

07 Thickness

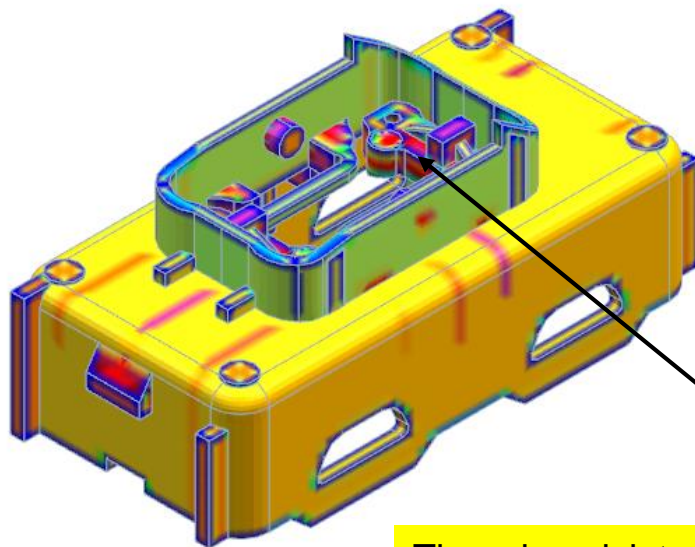

There is a risk to have sink mark on the surface in red.

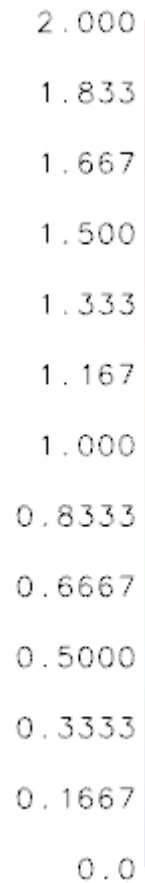
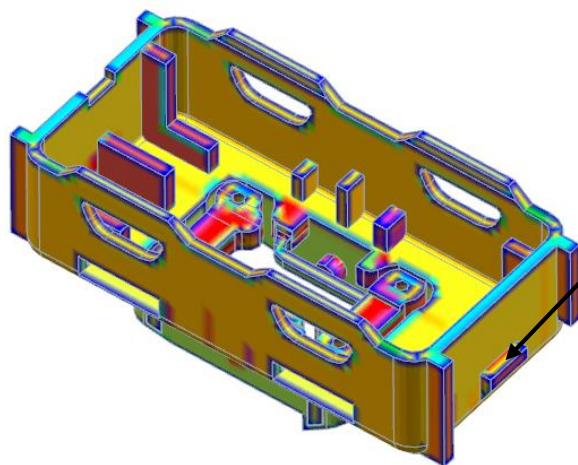

总体结果

平均厚度: 0.94

最大厚度: 2.43

08 Part question

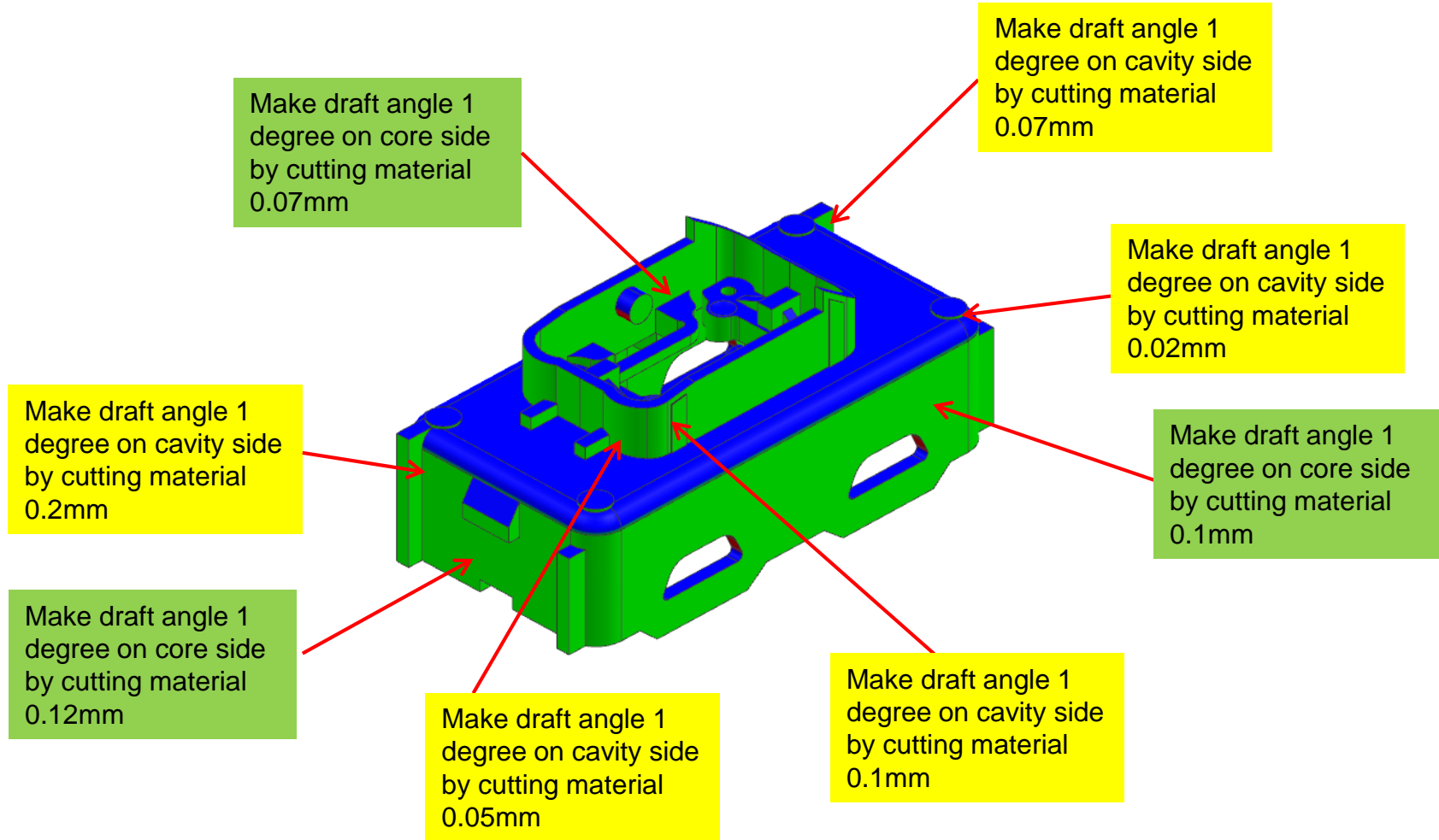

08 Part question

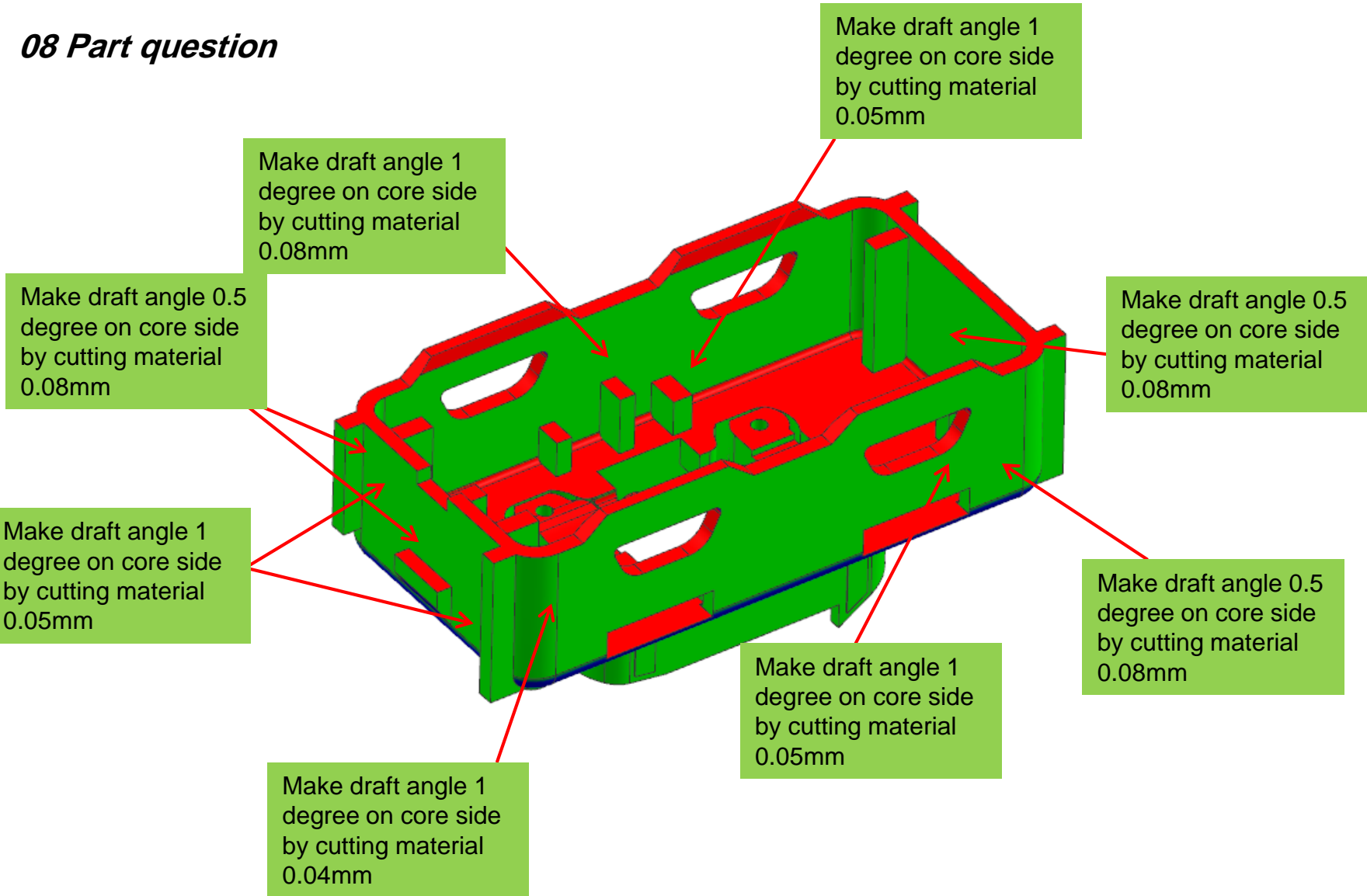

09 Engraves

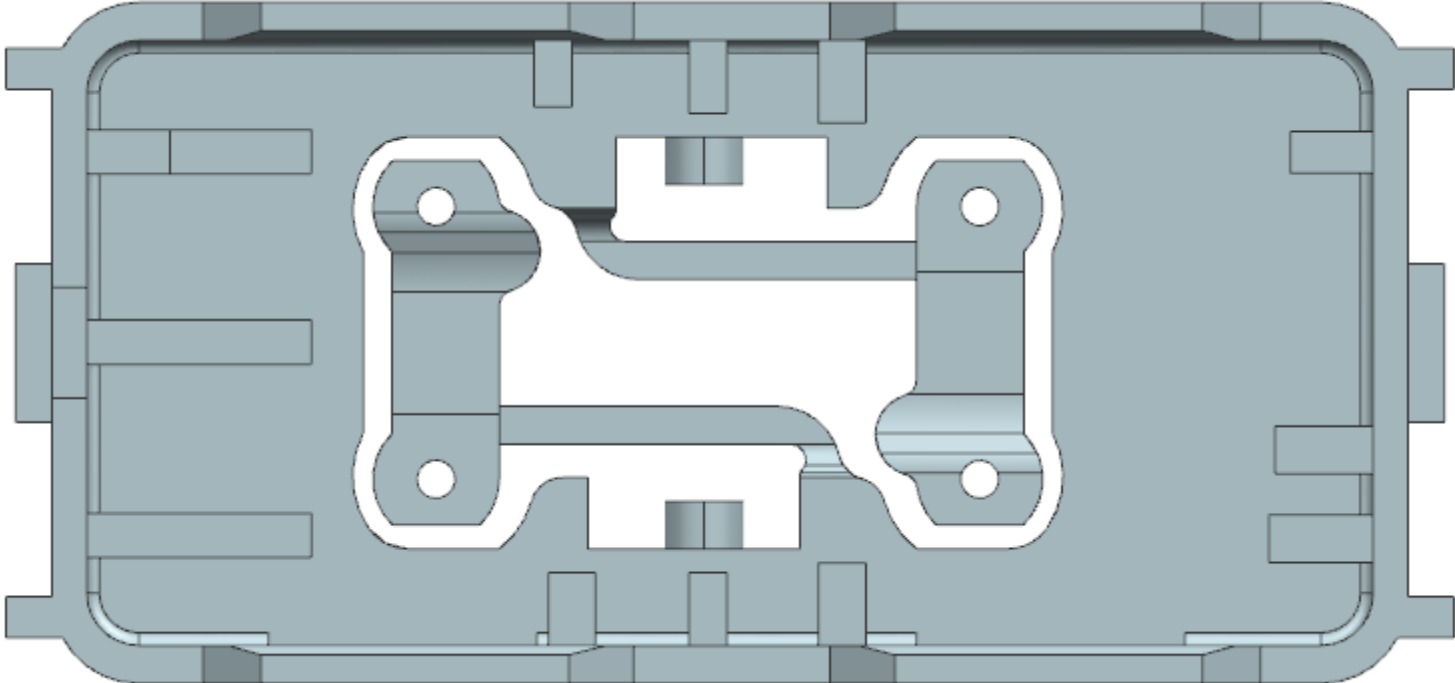

please provide the information of engraves.