



不銹鋼安全閥

STAINLESS STEEL SAFETY VALVES

HL83P 密閉式 Sealing 1/2"~2"

HL8-LSP 手拉式 Lever 1/2"~2"

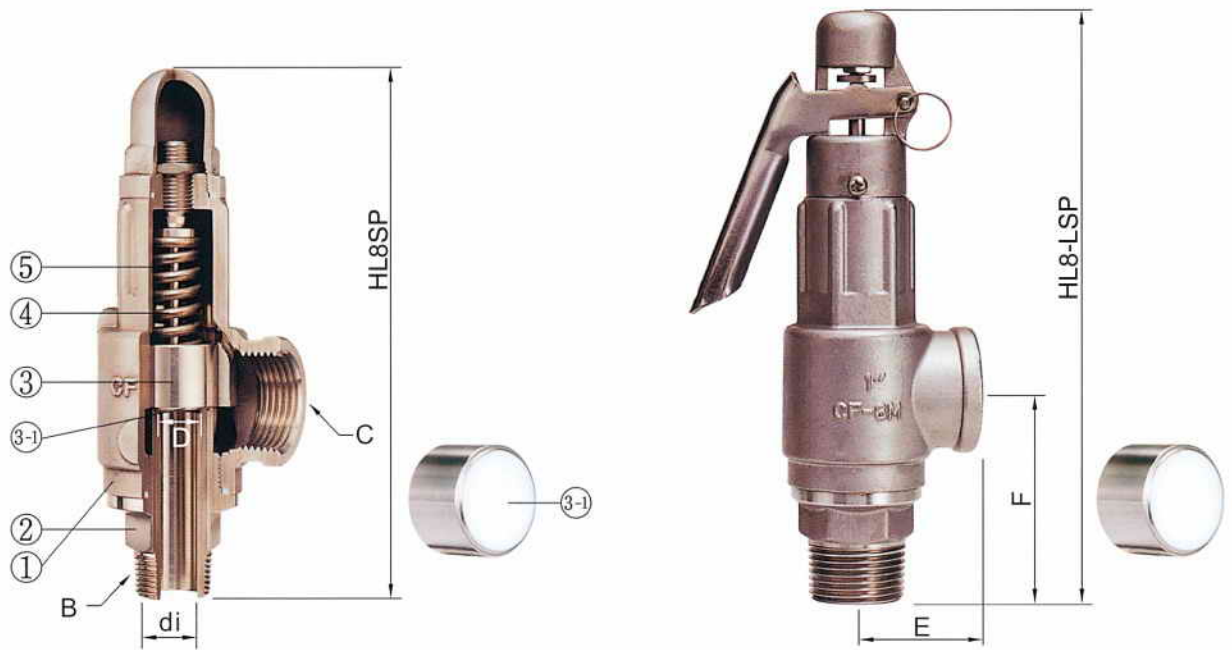

尺寸表 Dimensions

(密閉式 Sealing)

單位 Unit:mm

(手拉式 Lever)

單位 Unit:mm

項目 Item	HL8SP	入口 Inlet	出口 Outlet	入口徑 Inlet orifice	閥座徑 Valve seat orifice	E	F	揚程 Lift	重量 Wt. kg	項目 Item	HL8-LSP	重量 Wt. kg
		B	C	di	D							
1/2"x1"	176	1/2"	1"	13	22	40	67	0.88	1.1	1/2"x1"	199	1.3
3/4"x1"	176	3/4"	1"	19	22	40	67	0.88	1.2	3/4"x1"	199	1.3
1"x1"	180	1"	1"	25	22	40	71	0.88	1.2	1"x1"	203	1.3
1-1/4"x2"	255	1-1/4"	2"	32	38	66	93	1.52	4.6	1-1/4"x2"	279	4.8
1-1/2"x2"	260	1-1/2"	2"	38	38	66	98	1.52	4.6	1-1/2"x2"	284	4.8
2"x2"	260	2"	2"	50	38	66	98	1.52	4.6	2"x2"	284	4.9

材質表 General Material

序號 NO.	零件 Parts Name	型式 Type	HL8SP 密閉式 Sealing	HL8-LSP 手拉式 Lever
1	閥體 Valve Body		CF8M (不銹鋼)	
2	閥座 Valve Seat		CF8M (不銹鋼)	
3	閥盤 Disc		SUS 316 (不銹鋼)	
3-1	軟墊 Soft Seal		Teflon (PTFE)	
4	彈簧 Spring		SUS 304 (不銹鋼)	
5	閥桿 Stem		SUS 316 (不銹鋼)	
使用壓力 Working Pressure			2~10 kgf/cm ²	11~20 kgf/cm ²
使用溫度 Working Temp			-60 °C~196 °C	
使用流體 Working Fluid			非腐蝕性氣體、非腐蝕性液體、腐蝕性氣體、 腐蝕性液體、空氣、蒸氣、水、油 Noncorrosive Gas、Noncorrosive Liquid、Corrosive Gas、 Corrosive Liquid、Air、Steam、Water、Oil	非腐蝕性氣體、腐蝕性氣體、 空氣、蒸氣 Noncorrosive Gas、 Corrosive Gas、Air、Steam