

› Bolting Systems™

spxboltingsystems.com



HYDRAULIC SPREADER KITS



15 TON WEDGE-DRIVEN SPREADER

SPX®

Order No.: FLS15

With serrated shoes - shown in wedge fully open position.



Order No.: FLS15-ST

With stepped shoes - shown in wedge closed position.



Features & Benefits

- 33,000 pound (15 metric ton) spreader features an incorporated wedge design that provides structural support to the shoes throughout the tool range to maximize tool longevity and performance.
- Jaws fully supported by wedge for excellent durability
- Ideal for flanges with narrow gaps - only 5 mm (.2 inches) required for entry
- Compact and lightweight design - only 287 mm (11.28 inches) long at a weight of 3.2 kg (7 pounds)
- Suitable for the offshore environment due to superior corrosion resistance
- Quick adjustments for various tasks due to interchangeable shoes (both stepped and serrated)
- Includes female half coupler - mates to standard 3/8" male half coupler (No. 9798).

▶ FLS15 Serrated Shoe Spreader

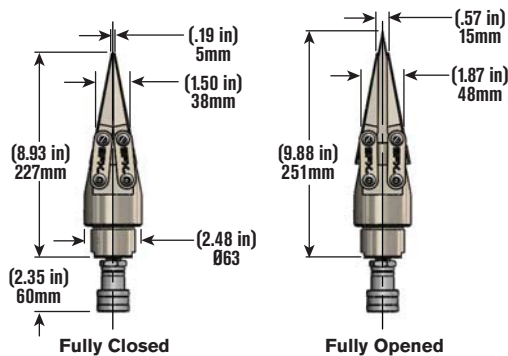

▶ FLS15-ST Stepped Shoe Spreader

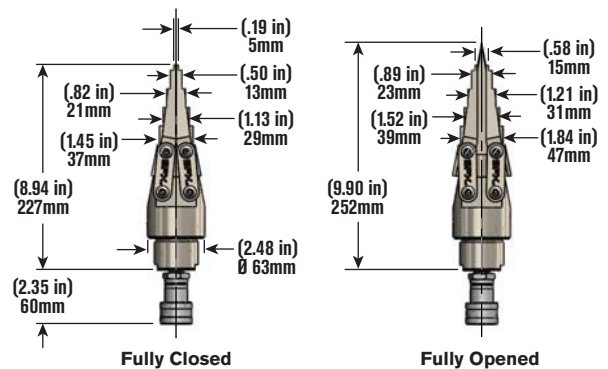

▶ Ordering Information

Order No.	Shoe Type	Maximum Spreading Force	Minimum Tip Clearance	Maximum Tip Spread	Spreader Type	Oil Capacity	Weight	Maximum Operating Pressure
		Metric Tons (lb)	mm (in)	mm (in)		cc (in ³)	kg (lb)	bar (psi)
FLS15	Serrated	15 (33,000)	5 (0.19)	15 (.57)	Hydraulic	16 (1)	3.2 (7)	700 (10,000)
FLS15-ST	Stepped							

▶ **Topside Flange Spreader Kit**



Features & Benefits

- Standard duty blow molded case organizes and protects the complete spreading kit
- Extra storage space for additional step shoes and up to 3 step blocks
- CE kits designed for European market and have a “bar” gauge
- Non-CE kits are for American market and have a “psi” gauge

Order No.		Kit Contents							
		FLS15	FLS15-ST	SB15	P19L			2008410	2008650
		Hydraulic Spreader, Serrated Shoes	Hydraulic Spreader, Stepped Shoes	Aluminum Holding Block	Lightweight Hand Pump	Manifold Assembly	Hoses	Handle for Spreader	Standard Case
FLS15-FBK	CE	2	-	2	1	1	3	2	1
FLS15-MBK	CE	1	-	3	1	-	1	1	1
FLS15-FBK-ST	CE	-	2	2	1	1	3	2	1
FLS15-MBK-ST	CE	-	1	3	1	-	1	1	1
FLS15-FBP		2	-	2	1	1	3	2	1
FLS15-MBP		1	-	3	1	-	1	1	1
FLS15-FBP-ST		-	2	2	1	1	3	2	1
FLS15-MBP-ST		-	1	3	1	-	1	1	1

▶ **Offshore Flange Spreader Kit**



Features & Benefits

- Heavy duty case is more rugged and compact, ideal for offshore applications
- Weather proof gasket seal and pressure equalization valve on the case
- Tighter product spacing for easier helicopter transport
- Gauges on manifold assembly display “bar” as primary units and “psi” as secondary

Order No.		Kit Contents							
		FLS15	FLS15-ST	SB15	P19L			2008577	3008832
		Hydraulic Spreader, Serrated Shoes	Hydraulic Spreader, Stepped Shoes	Aluminum Holding Block	Lightweight Hand Pump	Manifold Assembly	Hoses	Heavy Duty Case, Large	Heavy Duty Case, Small
FLS15-FSK	CE	2	-	2	1	2	3	1	-
FLS15-FSK-ST	CE	-	2	2	1	2	3	1	-
FLS15-MSK	CE	1	-	1	-	-	-	-	1
FLS15-MSK-ST	CE	-	1	1	-	-	-	-	1

› Bolting Systems™

SALES, SERVICE AND RENTAL CENTERS

Houston, Texas USA

3030 E. Pasadena Frwy
Pasadena, TX 77503
USA
Tel: +1 713 472 2500
Fax: +1 713 472 2501
houston@spxboltingsystems.com

Baton Rouge, Louisiana USA

12742 Ronaldson Road
Baton Rouge, LA 70807
USA
Tel: +1 225 774 0888
Fax: +713 472 2501
louisiana@spxboltingsystems.com

Rockford, Illinois USA

5885 11th Street
Rockford, IL 61109
USA
Tel: +1 815 874 5556
Fax: +1 800 288 7031
info@spxboltingsystems.com

ENGINEERING, MANUFACTURING AND SUPPORT CENTERS

World Headquarters

5885 11th Street
Rockford, IL 61109, USA
Tel: +1 815 874 5556
Fax: +1 800 288 7031
info@spxboltingsystems.com

European Headquarters

Albert Thijsstraat 12
6471 WX Eygelshoven
The Netherlands
Tel: +31 45 567 8877
Fax: +31 45 567 8878
europe@spxboltingsystems.com

Aberdeen, UK

Howemoss Drive
Kirkhill Industrial Estate
Dyce AB21 0GL
Tel: +44 1224 722 895
Fax: +44 1224 729 712
aberdeen@spxboltingsystems.com

Brazil (Coming Soon)

Tel: +55 11 983 392196
brazil@spxboltingsystems.com

UAE (Coming Soon)

uae@spxboltingsystems.com

Ashington, UK

Unit 4, Wansbeck Business Park
Rotary Parkway
Ashington
Northumberland NE63 8QW
europe@spxboltingsystems.com

Asia Pacific Headquarters

26 Soon Lee Road
Singapore 628086
Singapore
Tel: +65 6265 3343
Fax: +65 6265 6646
singapore@spxboltingsystems.com

Shanghai, China

No. 1568 Hua Shan Road
Treasury Building, 7th Floor
Shanghai 200052, China
Tel: +86 21 2208 5660/5659/5667
Fax: +86 21 2208 5682
china@spxboltingsystems.com

Perth, Australia

46 Callaway Street
Wangara, 6065
Perth, Western Australia
Tel: +61 8 9358 6699
Fax: +61 8 9358 6700
australia@spxboltingsystems.com

Visit us at spxboltingsystems.com



Bolting Systems: Your Partner In High Quality Bolting Tools



Distributed by:

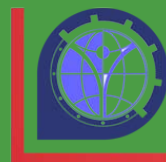

تامین صنعت پارلاتک
www.parla-tech.com
info@parla-tech.com

SPX®