



Delayed PZE X4V



Contact expander module for increasing the number of available contacts

Approvals

	PZE X4V
	◆
	◆
	◆

Unit features

- ▶ Positive-guided relay outputs:
 - 4 safety contacts (N/O), delay-on de-energisation
- ▶ Connection for feedback loop
- ▶ LED indicator for:
 - Switch status channel 1/2
- ▶ See order reference for unit types

Unit description

The unit meets the requirements of EN 60204-1 and IEC 60204-1. The contact expander module is used to increase the number of contacts available on a base unit. Base units are all safety relays with feedback loop. The category that can be achieved in accordance with EN 954-1 depends on the category of the base unit. The contact expander module may not exceed this. The delay-on de-energisation safety contacts may only be used up to category 3.

Safety features

The unit meets the following safety requirements:

- ▶ The contact expander module expands an existing circuit. As the output relays are monitored via the base unit's feedback loop, the safety functions on the existing circuit are transferred to the contact expander module.
- ▶ The safety function remains effective in the case of a component failure.
- ▶ Earth fault in the feedback loop: Detected, depending on the base unit that is used.
- ▶ Earth fault in the input circuit: The output relays de-energise and the safety contacts open.

Block diagram

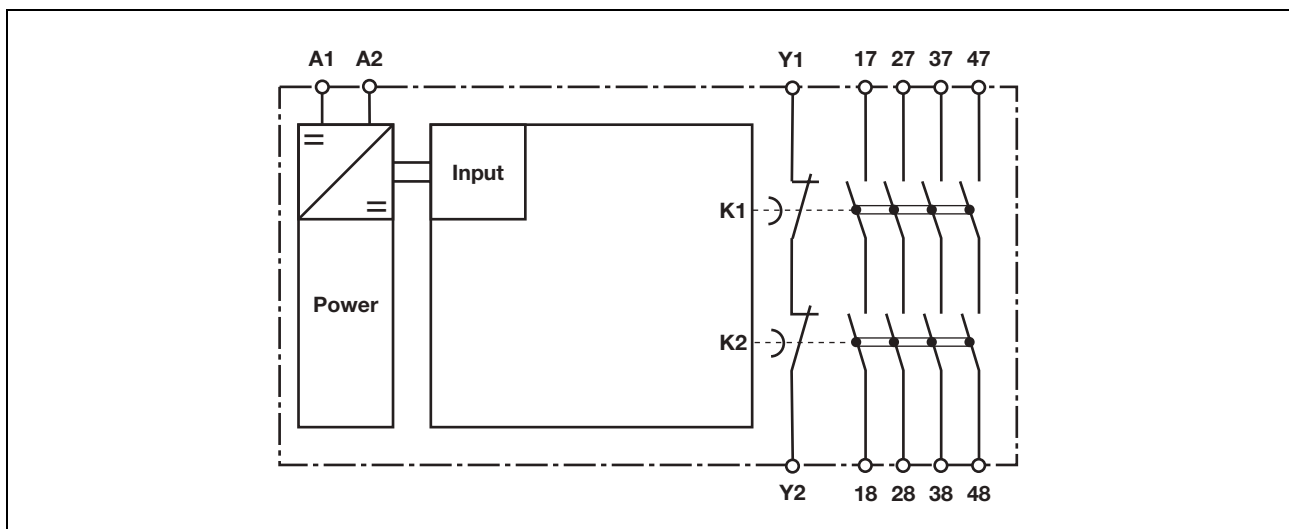

Delayed PZE X4V

Function description

- ▶ Single-channel operation: one input circuit affects both output relays

Timing diagram

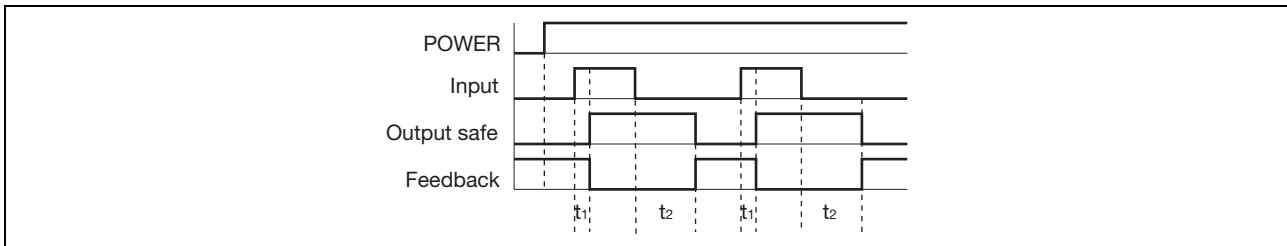

Key

- ▶ Power: Supply voltage
- ▶ Input: Input circuits A1
- ▶ Output safe: Safety contacts 17-18, 27-28, 37-38, 47-48
- ▶ Feedback: Feedback loop Y1-Y2
- ▶ t_1 : Switch-on delay
- ▶ t_2 : Delay-on de-energisation

Wiring

Please note:

- ▶ Information given in the “Technical details” must be followed.
- ▶ Outputs 17-18, 27-28, 37-38, 47-48 are delay-on de-energisation safety contacts.
- ▶ To prevent contact welding, a fuse should be connected before the output contacts (see technical details).
- ▶ Calculation of the max. cable runs I_{\max} in the input circuit:

$$I_{\max} = \frac{R_{l\max}}{R_l / \text{km}}$$

$R_{l\max}$ = max. overall cable resistance (see technical details)
 R_l / km = cable resistance/km

- ▶ Use copper wire that can withstand 60/75 °C.
- ▶ Sufficient fuse protection must be provided on all output contacts with capacitive and inductive loads.

Delayed PZE X4V

Preparing for operation

▶ Supply voltage

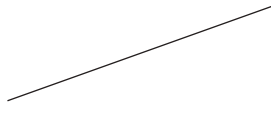
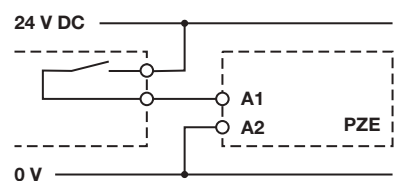
Supply voltage	AC	DC
		

▶ Input circuit

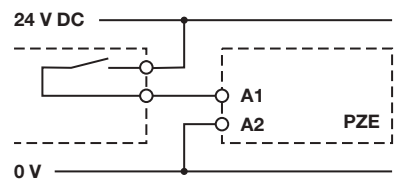
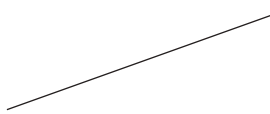
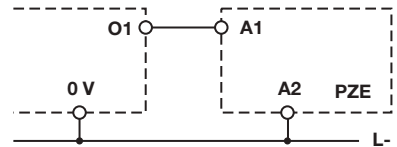
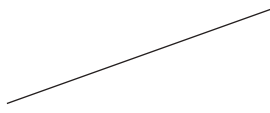
Input circuit	Single-channel	Dual-channel
Base unit: PNOZ X safety relay Driven via safety contacts		
Base unit: PNOZelog safety relay Driven via semiconductor outputs (24 VDC)		

▶ Feedback loop

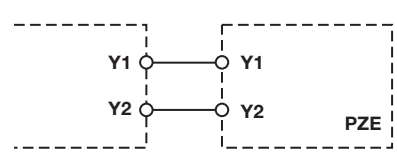
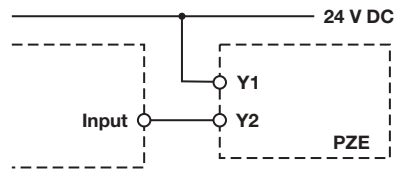
Feedback loop	Base unit: PNOZ X safety relay	Base unit: PNOZelog safety relay
Y1, Y2 and Input are inputs on the base unit; they evaluate the feedback loop		

Delayed PZE X4V

Terminal configuration

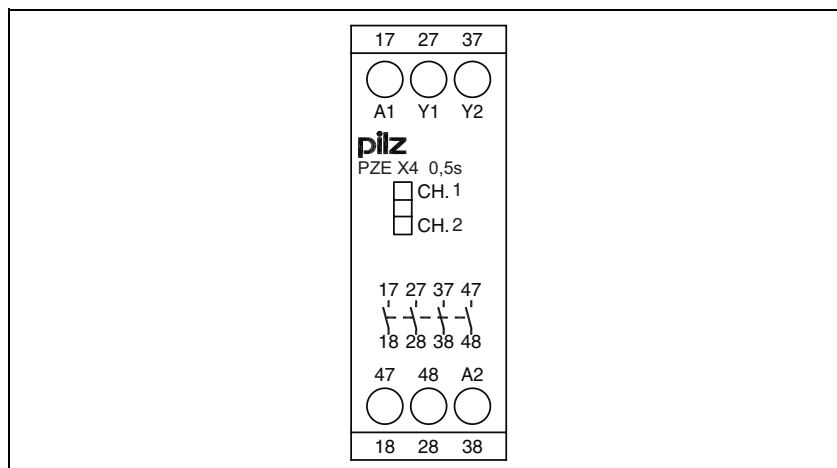

Installation

- ▶ The safety relay should be installed in a control cabinet with a protection type of at least IP54.
- ▶ Use the notch on the rear of the unit to attach it to a DIN rail.
- ▶ Ensure the unit is mounted securely on a vertical DIN rail (35 mm) by using a fixing element (e.g. retaining bracket or an end angle).

Dimensions

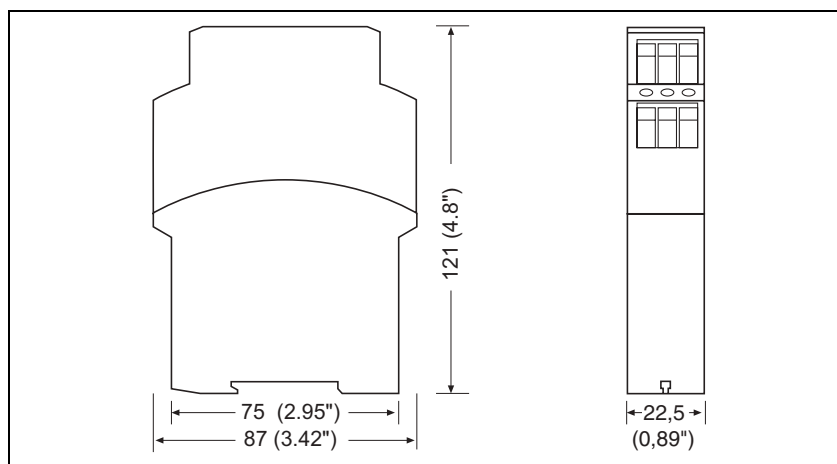

Delayed PZE X4V

Notice

This data sheet is only intended for use during configuration. For installation and operation, please refer to the operating instructions supplied with the unit.

Service life graph

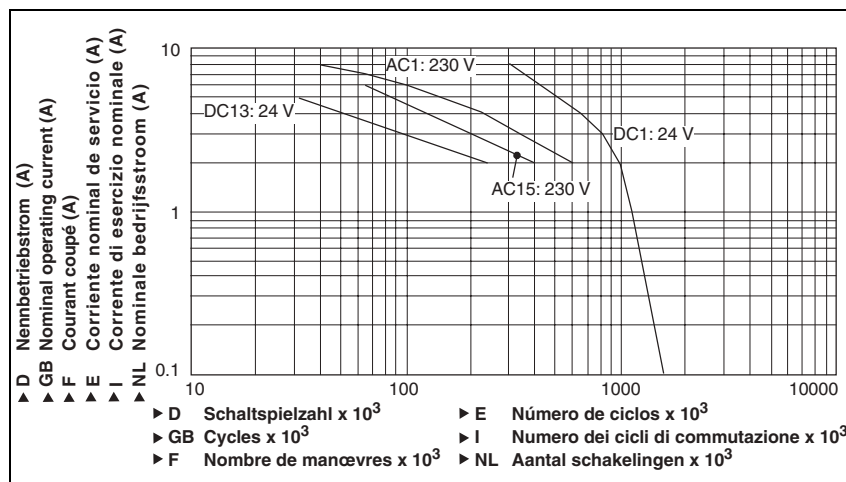

Technical details

Electrical data

Supply voltage U_B DC	24 V
Voltage tolerance	-15 % / +10 %
Power consumption at U_B DC	2.5 W
Residual ripple DC	20 %
Voltage and current at Input circuit: 24 VDC	85 mA
Output contacts in accordance with EN 954-1, Category 4	Safety contacts (N/O): 4
Utilisation category in accordance with EN 60947-4-1 AC1: 240 V	$I_{min}: 0.01 \text{ A}, I_{max}: 5 \text{ A}$ $P_{max}: 1200 \text{ VA}$
DC1: 24 V	$I_{min}: 0.01 \text{ A}, I_{max}: 5 \text{ A}$ $P_{max}: 120 \text{ W}$
Utilisation category in accordance with EN 60947-5-1 AC15: 230 V	$I_{max}: 3 \text{ A}$
DC13 (6 cycles/min): 24 V	$I_{max}: 4 \text{ A}$
Contact material	AgSnO₂ + 0.2 µm Au
External contact fuse protection (EN 60947-5-1)	
Blow-out fuse, quick	6 A
Blow-out fuse, slow	4 A
Circuit breaker	4 A, 24 VAC/DC, characteristic B/C
Max. overall cable resistance R_{lmax} Input circuits Single-channel at U_B DC	30 Ohm

Delayed PZE X4V

Times	
Switch-on delay	
with automatic reset after power on typ.	23 ms
with automatic reset after power on max.	40 ms
Delay-on de-energisation	
with E-STOP typ.	0.5 s Order no.: 774580 0.75 s Order no.: 774586 1 s Order no.: 774581 2 s Order no.: 774582 3 s Order no.: 774583
with power failure typ.	0.5 s Order no.: 774580 0.75 s Order no.: 774586 1 s Order no.: 774581 2 s Order no.: 774582 3 s Order no.: 774583
Tolerance	-50 % / +50 %
Supply interruption before de-energisation	20 ms
Environmental data	
EMC	EN 60947-5-1, EN 61000-6-2
Vibration in accordance with EN 60068-2-6	
Frequency	10 - 55 Hz
Amplitude	0.35 mm
Climatic suitability	EN 60068-2-78
Airgap creepage	VDE 0110-1
Ambient temperature	-10 - 55 °C
Storage temperature	-40 - 85 °C
Protection type	
Mounting (e.g. cabinet)	IP54
Housing	IP40
Terminals	IP20
Mechanical data	
Housing material	
Housing	PPO UL 94 V0
Front	ABS UL 94 V0
Max. cross section of external conductors with screw terminals	
1 core flexible	0.20 - 4.00 mm²
2 core, same cross section, flexible:	
with crimp connectors, without insulating sleeve	0.20 - 2.50 mm²
without crimp connectors or with TWIN crimp connectors	0.20 - 2.50 mm²
Torque setting with screw terminals	0.60 Nm
Dimensions (H x W x D)	
with screw terminals	87 mm x 22.5 mm x 121 mm
Weight	200 g Order no.: 774580, 774586 205 g Order no.: 774581 215 g Order no.: 774582, 774583

The standards current on **09/04** apply.

Max. continuous current	
Number of contacts	I_{\max} (A) at U_B DC
1	5.0 A
2	5.0 A
3	4.5 A
4	4 A

Delayed PZE X4V

Order reference

Type	Features	Terminals	Order no.	
PZE X4V	24 VDC	0.5 s fixed	Screw terminals	774 580
PZE X4V	24 VDC	0.75 s fixed	Screw terminals	774 586
PZE X4V	24 VDC	1 s fixed	Screw terminals	774 581
PZE X4V	24 VDC	2 s fixed	Screw terminals	774 582
PZE X4V	24 VDC	3 s fixed	Screw terminals	774 583