

TORQUE WRENCH

HIGH CYCLE - TWHC

Max Torque 71,816 Nm at 700 bar
(53,000 lb-ft at 10,000 psi)



NEW TECHNOLOGY

TORQUE WRENCH - HIGH CYCLE

Quality means Lower Cost of Ownership:

- Designed for high cycle life: 2-3x more than existing technology
- Increased reliability: Simple drive assembly means less downtime
- Corrosion resistant material for use in harsh environments

Enhanced Usability:

- Compact nose radius allows the tool to fit in tighter, hard-to-reach spaces
- Low weight, high strength design
- Fast operation, long stroke and optimum flow
- Multi-direction high flow swivel manifold
- Push button square drive reversal and reaction arm positioning
- Push-button release of square drive & reaction arm for all models except TWHC50.

Designed with Safety in Mind:

- Fully enclosed drive mechanism for operator safety
- Swivel manifold internal relief valve prevents retract side over-pressurization
- Fine tooth pawl prevents tool 'lock-on'



تامین صنعت پارلاتک (سهام خاص)

فکس : ۸۸۸۹۱۶۳۸

تلفن : ۸۸۸۹۶۵۳۸

وب: www.parla-tech.com ایمیل: info@parla-tech.com

TWHC CONVERSION CHART, SEE PAGE 122.



HANDLES SOLD SEPARATELY

The tool's designed long-stroke mechanism imparts a minimum 30 degree nut rotation per stroke while maintaining a tight and compact nose radius: this is a clear advantage over the short stroke and back-up pawl mechanisms of light alloy competitive models. Fewer parts and reduced torsion in operation - equals reduced wear, maintenance and associated costs.

OK FOR SUBSEA

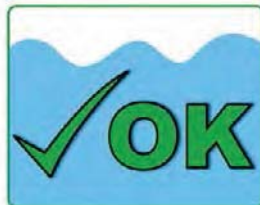

Specifications and Dimensional Data

TWHC

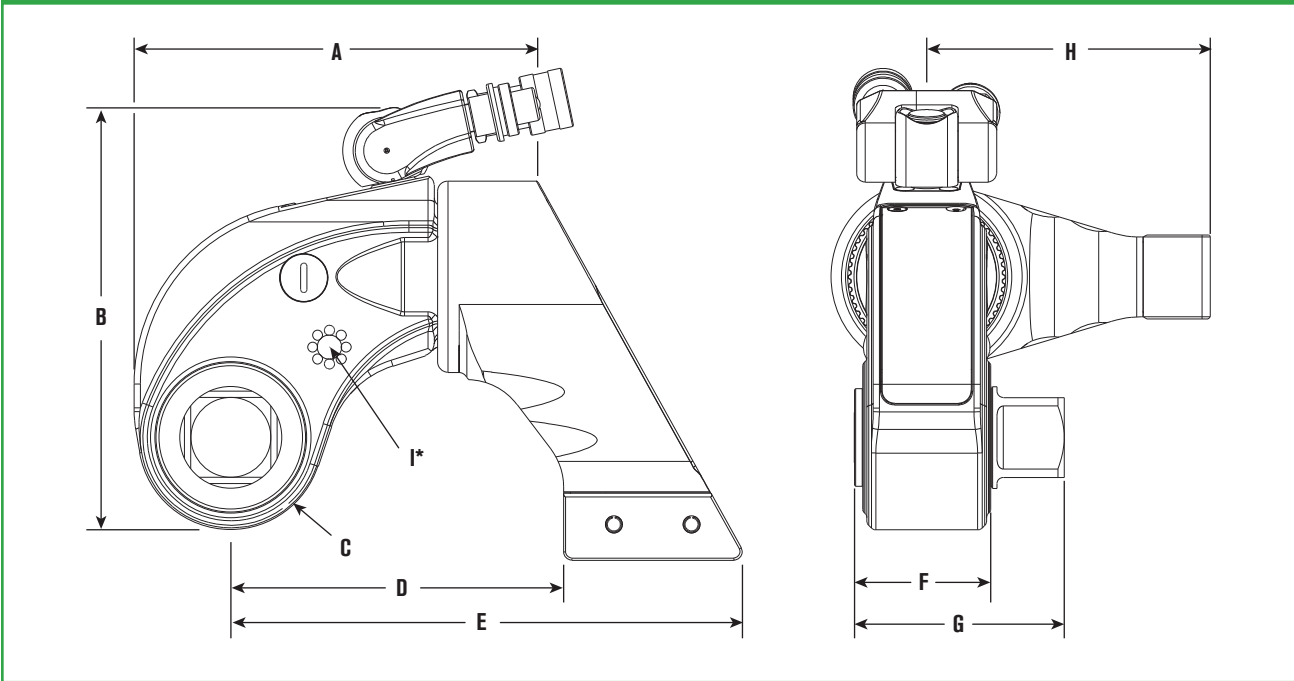

* Dimension I shows thread size (on both sides of the tool) for safety handle or lifting point. TWHC50 model available with lifting points only.

Tool Model	Min Torque		Max Torque		Square Drive	A	B	C	D	E	F	G	H	I	Weight	
	lb-ft	Nm	lb-ft	Nm		mm (in)	mm (in)	mm (in)	mm (in)	mm (in)	mm (in)	mm (in)	mm (in)		Kg	lb
TWHC1	170	230	1,413	1,915	3/4	132 (5.20)	145 (5.71)	28 (1.10)	111.5 (4.39)	170.0 (6.69)	39.5 (1.56)	67.7 (2.67)	86.1 (3.39)	M6 x 1.0	2.8	6.2
TWHC3	376	510	3,136	4,249	1	165 (6.50)	173.5 (6.83)	36.5 (1.44)	129.6 (5.10)	197.7 (7.78)	53 (2.09)	83.7 (3.30)	105.1 (4.14)	M6 x 1.0	5.3	11.7
TWHC6	726	984	6,050	8,198	1-1/2	192 (7.56)	201.6 (7.94)	44 (1.73)	158.5 (6.24)	243.7 (9.59)	61 (2.40)	99.9 (3.93)	135.1 (5.32)	M8 x 1.25	8.8	19.4
TWHC50	6,360	8,628	53,000	71,816	2-1/2	404.5 (15.93)	356.6 (14.04)	88 (3.46)	266.5 (10.49)	446.6 (17.58)	115 (4.53)	192.2 (7.57)	258 (10.16)	M12 x 1.75	69	152

Ordering Information

Order No.	Description	Order No.	Description	Order No.	Description
TWHC1	Wrench	TWHC1H	Wrench with handle	DFTAS000001	Handle for TWHC1
TWHC3	Wrench	TWHC3H	Wrench with handle	DFTAS000001	Handle for TWHC3
TWHC6	Wrench	TWHC6H	Wrench with handle	DFTAS000002	Handle for TWHC6
TWHC50	Wrench				

TORQUE WRENCH REACTIONS ARMS - TWHC

TWHC EXTENDED REACTION ARM TWHC-ERA



- Long reach version of TWHC standard reaction arm
- 3 standard sizes per model (+25mm/50mm/75mm), specials upon request
- Replaces standard reaction arm – quick release pin locking
- Steel alloy construction
- 360° rotation
- Available for full range of tool sizes

TW HANDLE



- Robust steel construction with ribbed polymer grip
- Multi-position on tool for balanced handling
- Cap-screw locking with positive 'docking'
- Is suitable for all wrench models (TWHC, TWSD, TWLC), however for larger sizes (TWSD25/TWLC 30/TWHC50) we recommend the use of eye-bolt lifting.

Specifications and Dimensional Data

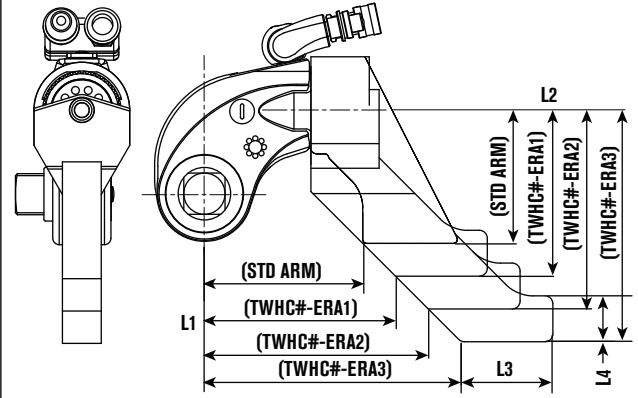

Tool Ref	Order No.	L1		L2		L3		L4	
		mm	in	mm	in	mm	in	mm	in
STD ARM		112	4.41	86	3.39				
TWHC1	TWHC1-ERA1	137	5.39	111	4.37				
	TWHC1-ERA2	162	6.38	136	5.35	60	2.36	30	1.18
	TWHC1-ERA3	187	7.36	161	6.34				
STD ARM		130	5.12	105	4.13				
TWHC3	TWHC3-ERA1	155	6.10	130	5.12				
	TWHC3-ERA2	180	7.09	155	6.10	70	2.76	35	1.38
	TWHC3-ERA3	205	8.07	180	7.09				
STD ARM		159	6.23	136	5.35				
TWHC6	TWHC6-ERA1	184	7.24	161	6.34				
	TWHC6-ERA2	209	8.23	186	7.32	95	3.74	40	1.57
	TWHC6-ERA3	234	9.21	211	8.31				

Order No.	Description	Tool Ref
DFTAS000001	Wrench Handle Size 1	TWSD1
		TWSD3
		TWHC1
		TWHC3
		TWLC2
DFTAS000002	Wrench Handle Size 2	TWSD6
		TWSD11
		TWHC6
		TWLC4
		TWLC8
		TWLC15

Specifications and Dimensional Data

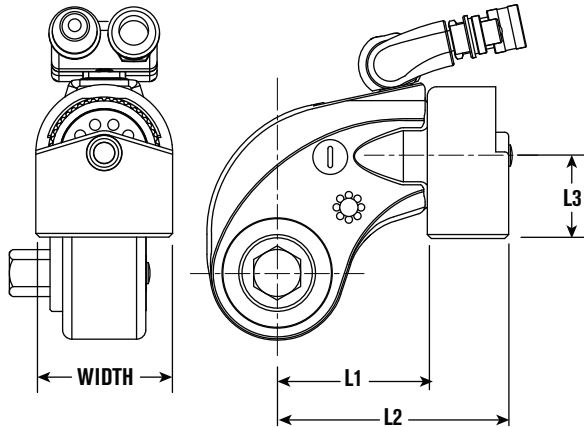

Tool Ref	Order No.	L1		L2		L3		Width	
		mm	in	mm	in	mm	in	mm	in
TWHC1	TWHC1-RP	72	2.835	116	4.567	49	1.93	64	2.52
TWHC3	TWHC3-RP	86	3.39	138	5.43	55	2.17	76	2.99
TWHC6	TWHC6-RP	99	3.90	162	6.38	62	2.44	89	3.50

TWHC REACTION PAD TWHC-RP



- Wrench In-Line Reaction Pad for TWHC wrench: used as simple pad or modified platform for specific application (Machine-able/Weld-able platform)
- Replaces standard reaction arm – quick release pin locking
- Steel alloy construction
- 360 degree rotation
- Available for full range of tool sizes

Specifications and Dimensional Data

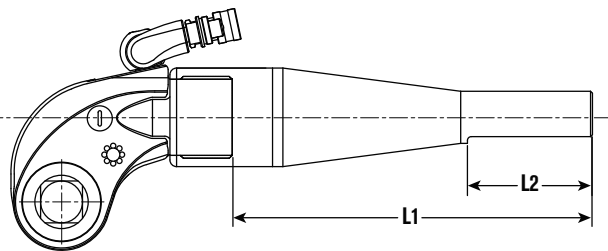

Tool Ref	Order No.	L1		L2	
		mm	in	mm	in
TWHC1	TWHC1-LRA	501	19.72	152	6
TWHC3	TWHC3-LRA				
TWHC6	TWHC6-LRA				

TWHC LONG REACTION ARM TWHC-LRA



- Tubular extension arm for TWHC wrench: in-line reaction outside wrench profile
- Replaces standard reaction arm – quick release pin locking
- Steel/light alloy construction (reaction flat machined on tube end)
- Can be cut down to suit specific length
- Available for full range of tool sizes