



Brüel & Kjær Vibro

Technische Dokumentation Technical Documentation Documentation Technique

VIBROCONTROL 920



All rights reserved
No part of this technical documentation may be reproduced
without prior written permission of Brüel & Kjær Vibro GmbH.

Subject to change without prior notice.

Copyright 2001 by Brüel & Kjær Vibro GmbH, D-64273 Darmstadt

Contents

1	General.....	3
1.1	OK Monitoring.....	4
1.2	VIBROCONTROL 920 operation after switch-on or power return.....	4
2	Technical Data	5
3	Display and operating elements	9
3.1	Button: MODE.....	9
3.2	Measured Value / Parameter	9
3.3	Display period	9
3.4	Status signals.....	10
3.5	Reset	11
3.6	Store	11
4	Internal Tests and Error Signals.....	13
4.1	Test of the LED display and alarm LEDs	13
4.2	Displaying the program version.....	13
4.3	Displaying the calibration constants.....	13
4.4	Error messages.....	13

- 5 **Setups** 15
 - 5.1 Function: Displaying parameters..... 15
 - 5.2 Function: Changing parameter values 16
 - 5.3 Parameter: Group 1 17
 - 5.4 Parameter: Group 2 19
 - 5.5 Parameter: Group 3 Service Parameter..... 22

- 6 **Mounting and Installation** 23
 - 6.1 Mounting and Installation Instructions..... 23
 - 6.2 Connecting Cable shields (*¹) 24
 - 6.3 Shield earth (*²)..... 24
 - 6.4 Mounting 25

- 7 **Wiring diagrams** 27

- 8 **Service** 32

- 9 **Instrument versions** 33

- 10 **Parameter list** 34

VIBROCONTROL 920

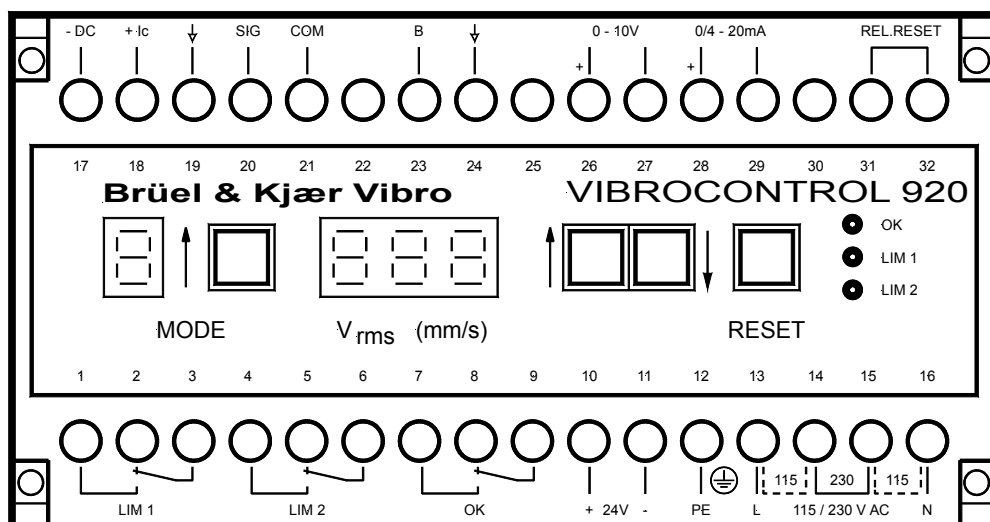

VC920 (030224)

1 General

VIBROCONTROL 920 is an instrument for measurement, monitoring and display of bearing resp. housing vibrations. The amplitude of the current measurement is displayed as the effective (rms) value of vibration velocity directly at the instrument on a three-digit, seven-segment LED display.

The standard sensor connected to the VIBROCONTROL 920 is normally a vibration velocity sensor. When an acceleration sensor is used the signal is integrated to the corresponding value of vibration velocity.

Two adjustable limit values, within the same full scale range, are available for signalling alarms. To prevent the alarm relays being activated by short-term high vibration levels which exceed the alarm values, a time delay can be activated for each individual alarm relay. Limit value exceedances are displayed on the VIBROCONTROL 920 by alarm LEDs while the exceedances can be signalled further using the respective potential-free alarm relay contacts.

Setting up of the instrument for the measurement and monitoring task is done by means of setup parameters.

A diagnosis output (terminals B / ↓) is available for checking purposes and enables analysis of the input signal with correct phase.

All cable connections to the instrument are made by means of screw terminals.

1.1 OK Monitoring

Self-monitoring of the power supply, the internal microprocessor system as well as the sensor status is done by the OK monitoring system.

An existing OK error is displayed by an LED and signalled by the change-over of potential-free contacts of the OK relay. In the case of a fault the light-emitting diode will go off and the contacts of the corresponding relay will change over.

1.2 VIBROCONTROL 920 operation after switch-on or power return

The instrument automatically executes a self-test lasting approximately 6 secs. each time it is switched on. Through this a calibration constant for the measuring circuit is determined which is then calculated into the results of all future measurements. During this self-test phase the status of the OK and limit relays is retained as defined for an error-free condition.

After completion of the self-test the instrument switches to the monitoring operation. After this time any exceedances of the pre-defined limit and calibration values lead to corresponding event signals.

2 Technical Data

Power supply	115 / 230 V AC 50 / 60 Hz	+/- 15 %;
	24 V DC	-25 % / +33 %
Load	AC: P _{max} : 12 VA DC: P _{max} : 7 W	
Standard delivery	230 V AC	
Fuses	24 V DC: fine-wire fuse 300 mA/tr 115 / 230 V AC: temperature fuse in the transformer	

Caution

Only one type of power may be connected at one time.

Measurement variable	Effective (rms) value of vibration velocity
Frequency range	1 ... 1000 Hz ¹ 10 ... 1000 Hz
Accuracy	± 5 %, in relation to displayed value
Internal resistance	R _{i AC} = 35 kΩ R _{i DC} = 39 kΩ

Sensor types

Vibration acceleration sensor

Sensitivity	10 mV/g x (0.1 ... 1.99) 100 mV/g x (0.1 ... 1.99)
Power requirement	-24 V DC / 5 mA
Current requirement	+ 4 mA / R _i < 4 kΩ

Vibration velocity sensor

Sensitivity	75 mV/mm/s x (0.1 ... 1.99) 100 mV/mm/s x (0.1 ... 1.99)
-------------	---

Analog outputs

Short-circuit proof	0 ... 10 V 0 / 4 ... 20 mA	R _L > 10 kΩ R _L < 500 Ω
---------------------	-------------------------------	--

¹ Type VC-920-2k = 10 ... 2000 Hz

Diagnostic outputs (Buffer) frequency range

Input	1 V _{pp} ; 10 Hz < f _o < 1 kHz
Transmission factor	1 : 1 (see note)
Amplitude error	< 0.5 % in relation to input signal
Phase error	< 0.5 % in relation to input signal
Load resistance	> 3,3 kΩ

Note

This indication applies to the connecting cable AC-185 not longer than 20 m.

Relay outputs

Potential-free contacts

Contact load:	Ohmic load: 100 W / 600 VA max. 30 V DC; 300 V AC, 3 A
---------------	---

Caution

With an inductive load a suitable spark-suppression device must be employed. The spark-suppression device must be installed as near as possible to the source of the interference.

Temperature ranges	0 ... 50 °C working temperature range -10 ... 70 °C storage temperature range
Protection type	IP 20
Fire protection class	according to UL94: V - 0 according to VDE 0304: Class IIb
Cable connection	Screw terminals Connection cross-sectional area max. 2,5 mm ²
Weight	920 g
Dimensions	150 mm x 78 mm x 115 mm (W x H x D)

Executed Environmental Tests

The VIBROCONTROL 920 conforms to the following prescribed standards and guidelines:

73/023/EWG, 93/68/EWG

EN 61010-1, 1993, 5.1ff
 IEC 68-2-1
 IEC 68-2-14
 EN 61010-1, 5.1.3, 5.4.2
 EN 61010-1, 6.7
 EN 61010-1, 9.1
 EN 61010-1, 6.8.4
 EN 61010, 8.3

Low-voltage guideline

EN 61010-1, 6.2
 IEC 68-2-2
 IEC 68-2-33
 EN 61010-1, 6.5.1
 IEC 348: 11.4
 EN 61010-1, 6.3
 VDE 0160, 7.6.2

89/336/EWG, 92/031/EWG

EMV-Guideline

Technical standard EN 50082-2:1995

Interference resistance: Industrial areas

ENV 50140:1993
 EN 61000-4-2:1995
 EN 61000-4-4:1995
 ICE SC 77A WG 6

ENV 50204:1995
 ENV 50141:1993
 EN 61000-4-11:1994
 EN 61000-4-5:1995

Technical standard EN 50081-1:1992

Interference emission: Residential areas

EN 55011:1991
 EN 60555-2:1987
 EN 55022:1994

EN 55022:1994
 EN 60555-3:1987
 92/031/EWG

Safety category according to EN-954-1

- Safety category B (Sk B) according to EN-954-1
- Safety category 1 (Sk 1) according to EN-954-1 under the following conditions:
 - If the system is used for applications requiring safety functions of the vibration monitoring system according to safety category 1, the relays have to be used in a closed circuit system.
 - The OK-relay has to be integrated into the safety chain in a way that the safety function is activated as soon as the relay responds.
 - All adjusting devices have to be protected in a way that they cannot be unintentionally misadjusted during operation. This can be done for instance by mounting the adjusting device in a closed housing resp. switch cabinet. Any opening of the housing/switch cabinet resp. changing of system parameters may only be done by duly trained, authorized staff and has to be documented.

3 Display and operating elements

3.1 Button: MODE

The operating mode of the instrument is changed by pushing the MODE button.

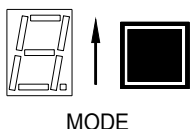

Normal operation

One push of the button; Preparation for parameter entry resp. check mode.

Parameter mode

Roll function; Each push of the button switches to the next operating mode

3.2 Measured Value / Parameter



Measurement value display

Three-digit, seven-segment LED display

The display resolution is automatically selected to correspond to the selected measurement range.



Buttons: Corresponding to the direction of the arrows, the setup value of the selected parameter will be increased or decreased by one step. If the button is pushed and held the single-step function will change to a rolling function.

3.3 Display period

The period the seven-segment LED display stays on can be defined between "Off after 3 minutes" or "Permanently on" and 3 levels of display brightness for each parameter can be selected. The display switches on when any of the function buttons is pushed.

3.4 Status signals

OK error

Green LED / OK relay

The occurrence of an OK error is signalled by the LED lighting up and the OK relay de-energizing.

LIM 1, LIM 2 error signals

The behaviour of the limit relays is determined by the connection status of the terminals 31/32 (Relay Reset).

Terminals 31/32 not connected resp. Contacts open

Limit value exceedances are stored - the limit relays remain energized - until the Reset button is pushed. A reset of the limit relay is only possible if the measurement value is lower than the corresponding limit value.

Terminals 31/32 connected by push-button

The energized limit relay contacts will be reset. A reset of the limit relay is only possible if the measurement value is lower than the corresponding limit value.

Terminals 31/32 permanently connected (Standard delivery)

The limit exceedance is signalled only for as long as the limit value is exceeded. If the measurement values fall lower than the limit values the LIM LEDs and the limit relays will be reset.

Limit value LIM 1

Yellow LED / LIM 1 Relay

If the current measurement value is higher than the limit value and remains at this level for longer than the set time delay, the LED will light up. The LIM 1 relay will react according to the defined setup. It will be energized when set up as normally de-energized and will be de-energized when set up as a normally energized relay.

If an OK error occurs during a LIM1 activation, the limit signal (LED and relay) will be reset to the normal status for the duration of the OK error.

Limit value LIM 2

Red LED / LIM 2 Relay

If the current measurement value is higher than the limit value and remains at this level for longer than the set time delay, the LED will light up. The LIM 2 relay will react according to the defined setup. It will be energized when set up as normally de-energized and will be de-energized when set up as a normally energized relay.

If an OK error occurs during a LIM2 activation, the limit signal (LED and relay) will be reset to the normal status for the duration of the OK error.

3.5 Reset



RESET

Normal operation

Reset the event signal as well as the associated relay.

The "REL.RESET" terminals have no function in connection with an OK error.

Parameter mode

Leave the parameter setup mode. Changes to the parameter values are not activated.

3.6 Store



MODE



RESET

Push Mode and Reset simultaneously:

Leave the parameter setup mode. Changes to the parameter values are activated.

This page is for your notes.

4 Internal Tests and Error Signals

After switching the instrument on a number of tests are executed. If the result of the test reveals an error in the operation of the instrument, this is displayed on the measurement value field in the form of an error message.

4.1 Test of the LED display and alarm LEDs

The LED seven-segment displays are checked by displaying the figure 8, and the associated decimal points are switched on. The alarm LEDs light up in the sequence green - yellow - red. This test lasts for approx. 4 seconds.

4.2 Displaying the program version

In the mode display field a "v" is displayed and in the measurement value display field the version number is displayed.

4.3 Displaying the calibration constants

In the mode display field a "c" is displayed and in the measurement value display field the calibration constants are displayed.

4.4 Error messages

The error messages are displayed in the form of an "E" followed by a number. The display of the measurement value is overwritten for the duration of the error message. In addition to the visual error signal, an error message is always signalled by activation of the corresponding limit or OK relay.

If the input of the measured value is overmodulated, the display shows „ccc„.

Error " E 01"

The value of the calibration constants lies outside the permissible range. A value between 0.5 and 2.0 is permitted. Occurrence of this error means an error in the instrument's internal acquisition electronics. The instrument should be removed from the monitoring application and returned to the nearest service station for repairs.

Error " E 02"

The values of the internal voltages lie outside the permissible limits. For a check see Group 3: Parameter 3 (+ 5 V) and Parameter 4 (+ 17 V). Occurrence of this error means an error in the instrument's power supply. The instrument should be removed from the monitoring application and returned to the nearest service station for repairs.

Error " E 03"

The temperature inside the instrument housing has exceeded the 90 °C ($\pm 10\%$) limit. If this error message occurs the instrument should be removed from the monitoring application and returned to the nearest service station for repairs.

Error " E 04"

OK-error identification

Always	Power failure
Vibration acceleration sensor	Cable break Short-circuit between the conductors
Vibration velocity sensor	Cable open circuit

In the event of this error the analog output will be switched to 0 volt resp. 0 / 4 mA. The OK LED will go off and the OK relay will de-energize and can only be reset using the RESET button. Until the cause of this error is eliminated the OK error signal will remain.

Error " E 05"

Failure of the OK monitoring function. This error shows a failure of the OK monitoring function. If this error message occurs the instrument should be removed from the monitoring application and returned to the nearest service station for repairs.

Error " ccc "

The measured value input is overmodulated. If the measured value is situated again within the measuring range the error message disappears.

5 Setups

General

The parameters are divided into three Groups each with respectively seven parameters. The parameters in Groups 1 and 2 are concerned with configuration parameters while those in Group 3 are concerned with service parameters.

Viewing or making changes to parameter values can only be done after first entering a code number associated with the Group. Parameter entries only take effect and are stored after leaving the entry mode, i.e. after simultaneously pushing the MODE + RESET buttons. Changes to the parameters are ignored when the entry mode is exited by pushing the RESET button.

5.1 Function: Displaying parameters

MODE button

Push once. The number 1 is displayed in the mode display field.

[↑] resp. [↓] buttons

Push repeatedly until the desired code number is displayed in the measurement value field.

MODE button

The mode selection is accepted. Now the parameter number 2 is displayed and the associated parameter value is displayed in the measurement value field.

MODE button

Pushing the MODE button switches to the next parameter.

RESET button

Pushing the RESET button exits the display mode. The corresponding value of the input signal is displayed in the measurement value field.

5.2 Function: Changing parameter values

MODE button

Push once. The number 1 is displayed in the mode display field.

[↑] resp. [↓] buttons

Push repeatedly until the code number associated with the corresponding parameter Group is displayed.

Parameter Group	Code Number
1	11
2	22
3	3

MODE button

The mode selection is accepted. Now the parameter number 2 is displayed and the associated parameter value is displayed in the measurement value field.

[↑] resp. [↓] buttons

Switching the parameter values to next higher resp. next lower value.

MODE button

By pushing the MODE button you can switch to the next parameter. If changes are made to the parameter values, these are saved in an intermediate memory until you exit the parameter mode.

MODE + RESET buttons

All parameter settings are accepted and take immediate effect. The parameter mode is exited; the corresponding value of the input signal is displayed in the measurement value field.

RESET button

Changes made to the parameter settings are ignored. The previous parameter values are retained. The parameter mode is exited; the value corresponding to the input signal is displayed in the measurement value field.

5.3 Parameter: Group 1

Mode 1 Code number

Value: 11

Mode 2 Range allocation for analog output

Default value: 20 mm/s

Value	Equals
10	0 ... 10 mm/s
20	0 ... 20 mm/s
50	0 ... 50 mm/s
100	0 ... 100 mm/s

Switching of measuring ranges

Switching from a smaller range to a larger range:

The defined limits values are retained.

Switching from a larger range to a smaller range:

As long as the defined limit values are larger than the new full scale they will be converted to the new full scale. If the defined limit values are lower than the new full scale they will be retained.

The automatic change in limit values will be signalled by flashing of the respective alarm limit LEDs (LIM 1 and LIM 2). To reset this flashing the limit value settings must first be changed, i.e. limit values lower than the full scale must be set and the instrument switched off and then on again for the change to take effect.

Mode 3 Limit value LIM 1

Default value: 4.5 mm/s

The adjustable range of the limit value is from 0 to the full scale value of the selected range. The resolution of the steps in the adjustment is in every case dependent on the selected range.

Range	Resolution
0 ... 10 mm/s	0,1 mm/s
0 ... 20 mm/s	0,1 mm/s
0 ... 50 mm/s	0,2 mm/s (x,0 - x,2 - x,5 - x,7)
0 ... 100 mm/s	1 mm/s

Mode 4 Limit value LIM 2

Default value: 7 mm/s

The adjustable range of the limit value is from 0 to the full scale value of the selected range. The resolution of the steps in the adjustment is in every case dependent on the selected range.

Range	Resolution
0 ... 10 mm/s	0,1 mm/s
0 ... 20 mm/s	0,1 mm/s
0 ... 50 mm/s	0,2 mm/s (x,0 - x,2 - x,5 - x,7)
0 ... 100 mm/s	1 mm/s

Mode 5 Time delay LIM 1

Default value: 10 s

The range of the adjustable time delay is from 0 ... 100 s. in steps of 1 second. The parameter is only effective when there is a limit exceedance.

Note:

The minimum setting „0“ corresponds to a time delay of 1 second.

Mode 6 Time delay LIM 2

Default value: 5 s

The range of the adjustable time delay is from 0 ... 100 s. in steps of 1 second. The parameter is only effective when there is a limit exceedance.

Note:

The minimum setting „0“ corresponds to a time delay of 1 second.

Mode 7 High-pass filter value

Default value: 10 Hz

Entered value	Active filter value
1	1 Hz (Vers. > 2.8)
10	10 Hz

5.4 Parameter: Group 2

Mode 1 Code number

Value: 22

Mode 2 Sensor sensitivity

Default value: 100 mV/mm/s

At the same time the sensitivity of an acceleration sensor is selected, the integration for conversion of vibration acceleration to vibration velocity is activated.

Selection	Value	Sensor for	Requirement
1	75 mV/mm/s	v	
2	100 mV/mm/s	v	
3	100 mV/g	a	-24 V
4	10 mV/g a	+ 4 mA	
5	100 mV/g	a	+ 4 mA
6	10 mV/g a	-24 V	

Meaning: a = Vibration acceleration
v = Vibration velocity

Mode 3 Correction factor

Default value: 1.00

To allow sensors which have a sensitivity other than those listed in parameter 2 of Group 2 to be used with the instrument, the selected value can be corrected with a factor in the range 0.1 to 1.99.

Mode 4 DC Current output range

Default value: 4 ... 20 mA

Selection	Range
0	0 ... 20 mA
4	4 ... 20 mA

Mode 5 Limit relays operating mode

Default value: 0

This parameter affects both limit relays.

Selection	Mode
0	Normally energized
1	Normally de-energized
Normally energized:	The relay de-energizes when the limit is exceeded
Normally de-energized:	The relay energizes when the limit is exceeded

Mode 6 LED 7-segment display

Default value: 0

With this parameter the duration and intensity of the LED seven-segment display is set up.

Selection	Mode
0	after 3 minutes the LED display goes off.
1 ... 3	The display switches on with maximum brightness. After 3 minutes the brightness is reduced to the selected factor.
4	Larger number = Brighter display Permanent display with maximum brightness

Mode 7 Analog output and Display test

Default value: 1

For test purposes various constant values, besides the standard signal, are switched to the analog outputs. To leave this test function activate RESET button.

Selection	Result
1	U 26/27 → corr. measurement signal I 28/29 → corr. measurement signal
2	U 26/27 → 0 V I 28/29 → 0 / 4 mA
3	U 26/27 → 10 V I 28/29 → 20 mA
4	U 26/27 → 5 V I 28/29 --> 10 / 12 mA

The LED seven segments are switched on one after the other to display an 8 and the respective decimal points are switch on. The alarm LEDs flash in the sequence: green – yellow – red.

The current status of the OK and limit relays are not influenced during this test.

5.5 Parameter: Group 3 Service Parameter

Mode 1 Code number

Value: 3

Mode 2 DC rest voltage of the sensor

The DC rest voltage of the sensor is displayed. This should be in case of sensors

- type AS-02x between -14 V DC and -10 V DC
- Typ AS-06x bei 12,5 V \pm 1,5V supply powered sensors
- type AS-06x (CCS) 13 V DC \pm 1,5 V constant-current powered sensors
- type VS-080 0,8 V DC

With more negative voltages the display will flash.

Mode 3 Internal voltage 5 Volt

The 5 Volt power for the internal components of the instrument is displayed. The value should be in the range 4.8 V to 5.2 V. Values outside this range lead to the error message 'E 02'.

Mode 4 Internal voltage 17 Volt

The 17 Volt power for the internal components of the instrument is displayed. The value should be in the range 16.8 V to 19.0 V. Voltage values outside this range will lead to the error message 'E 02'.

Mode 5 Housing internal temperature

The temperature inside the instrument housing is displayed in °C. If the temperature inside the instrument exceeds the predefined limit the error message 'E 03' will be displayed.

Mode 6 Input amplifier amplification factor

The current amplification factor of the input amplifier is displayed in steps of 1 - 2 - 4 - 8 - ... 128.

Mode 7 Output of the D/A converter

The display range of 0 ... 127 corresponds to 0 ... 20 mA

6 Mounting and Installation

6.1 Mounting and Installation Instructions

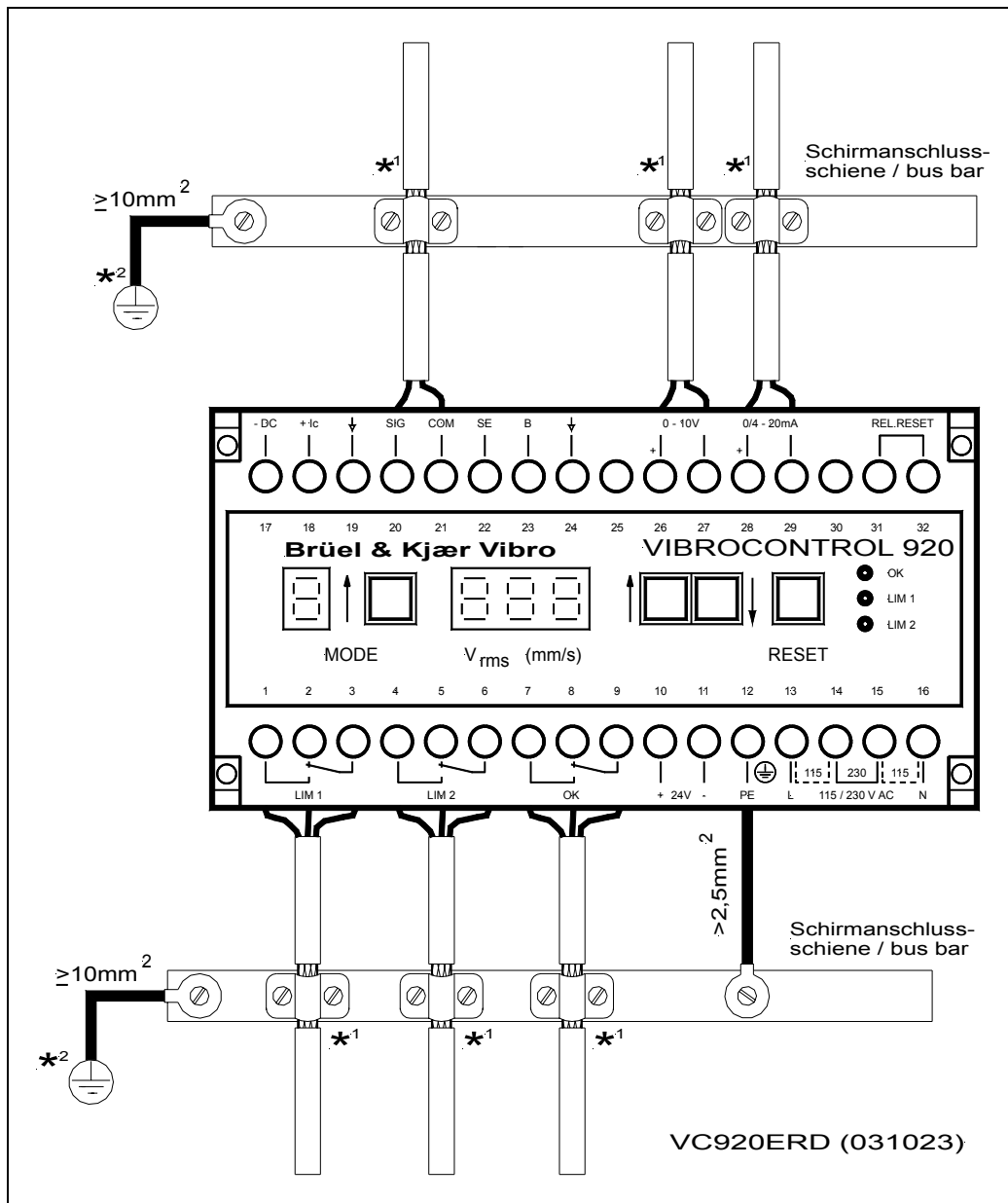

*1, *2 see the following page

The quality of the measurements and the security of the electromagnetic resistance is dependent on a fault-free interference discharge and thus also on the cabling **and disturbance-free grounding at the installation.**

The connecting cables for the

- sensor,
- analog outputs,
- the RESET contacts and the
- relay contacts

must be shielded.

6.2 Connecting Cable shields (*¹)

- ◆ The connections for the cable shields **must have as large an area as possible.**
- ◆ Use a grounding rail for connecting the shields (e.g. type 210-133 / Fa. Wago) with suitable shield clamping saddles (e.g. type 790-108 / Fa. Wago up to 8 mm cable diameter).
- ◆ Expose and shape the cable shield in the form of a ring at the height of the grounding rail **only to the width of the grounding rail**, so that the cable remains shielded right up to close to the VC-920. The cable shield must be exposed only over the grounding rail.
- ◆ Connect the grounding rail with short cable having a cross-sectional area of min. 10 mm² to an interference-free ground.

6.3 Shield earth (*²)

- ◆ Prerequisite for a fault-free interference discharge is a low-resistance and **interference-free** ground connection.

Important!

Observe our „General grounding recommendations,, before cabling the system.

6.4 Mounting

Real panel mounting	2 M4 x 15 screws or 2 M5 x 15 screws
Rail mounting	35 mm profile rail (EN 50 022)

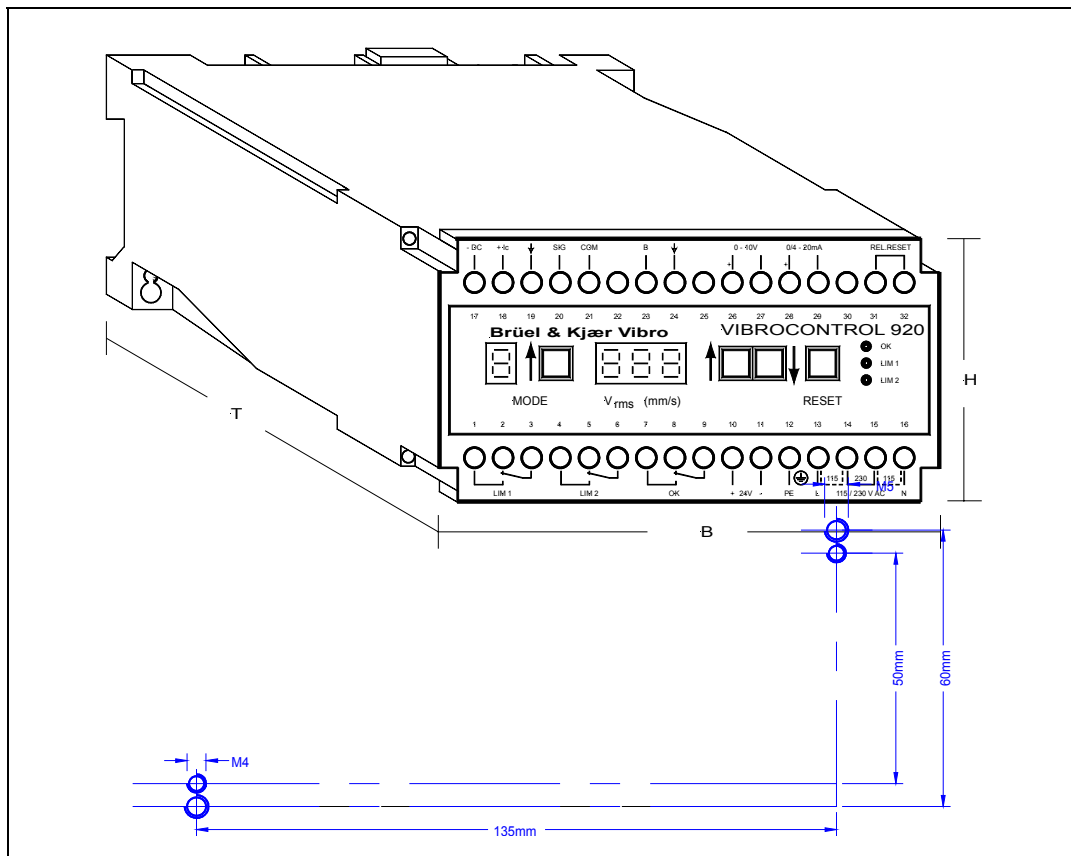

This page is for your notes.

7 Wiring diagrams

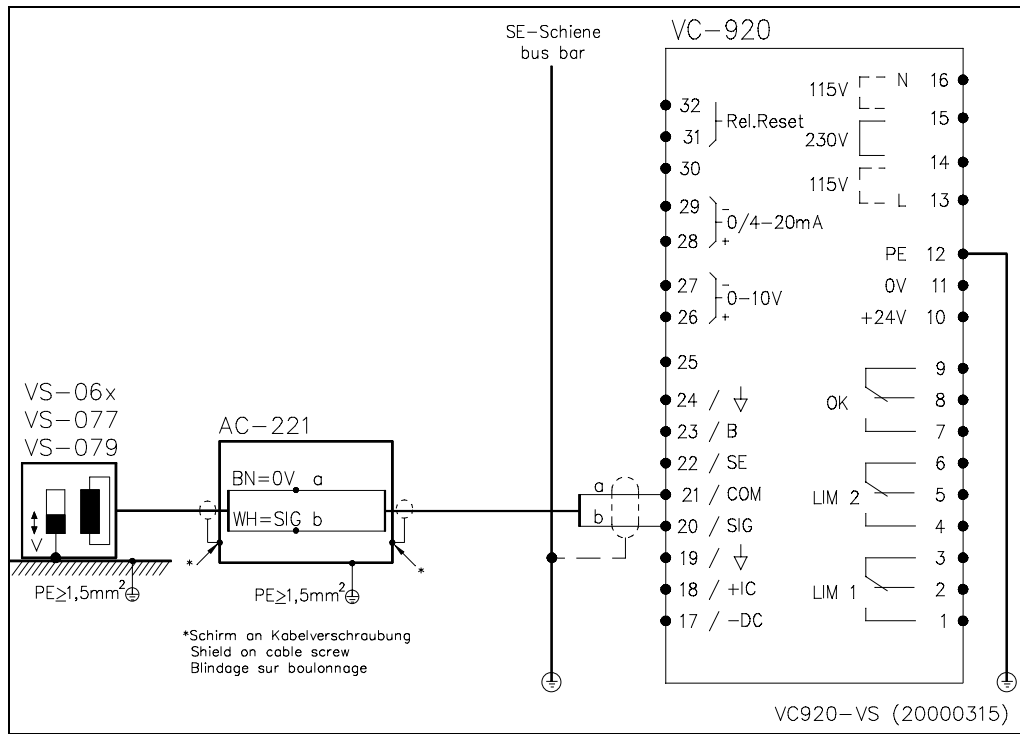

Vibration velocity transducer; standard connection (WH = white, BN = brown)

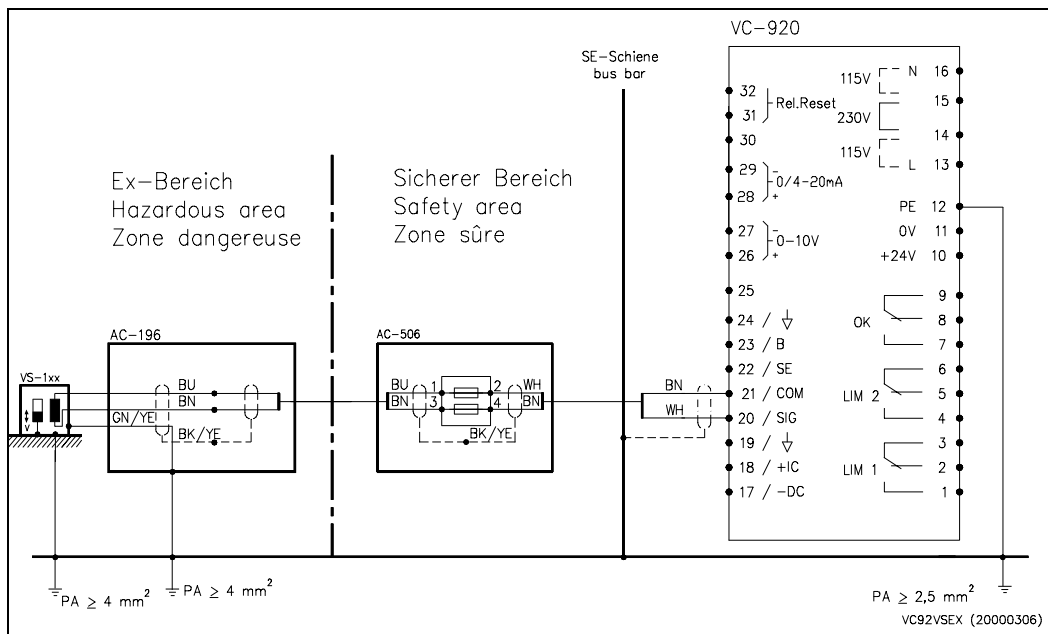

Vibration velocity transducer in Ex- area
(BU = blue, bn = brown, GN/YE = green/yellow, BK/YE = black/yellow, WH = white)

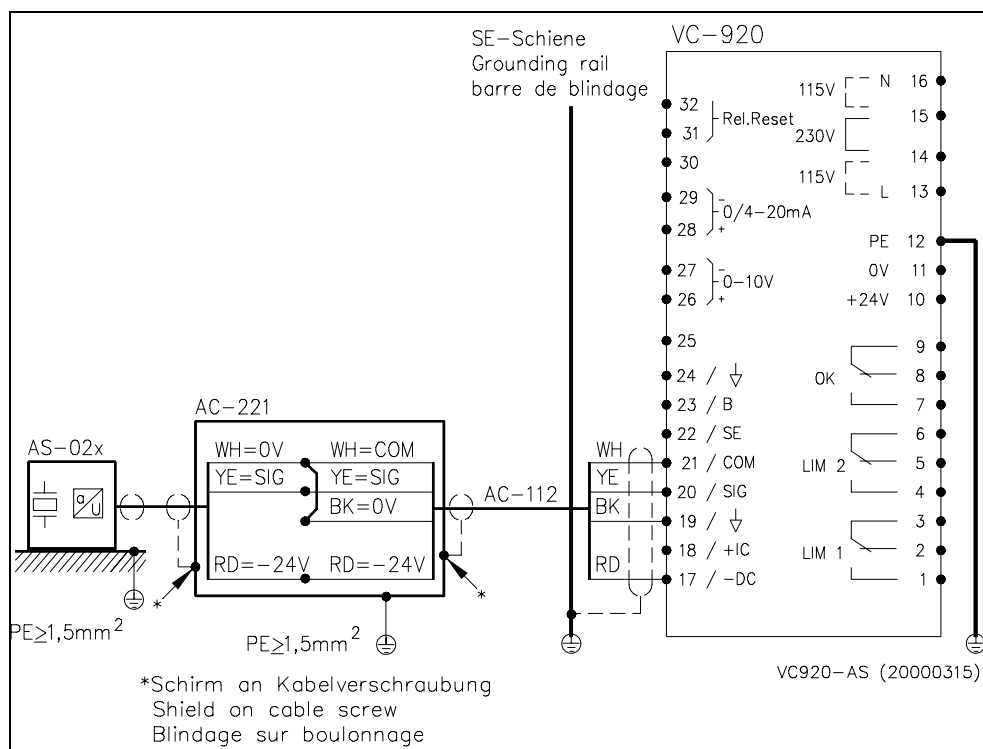

Vibration accelerometer; standard connection (WH = white, YE = yellow, RD = red)

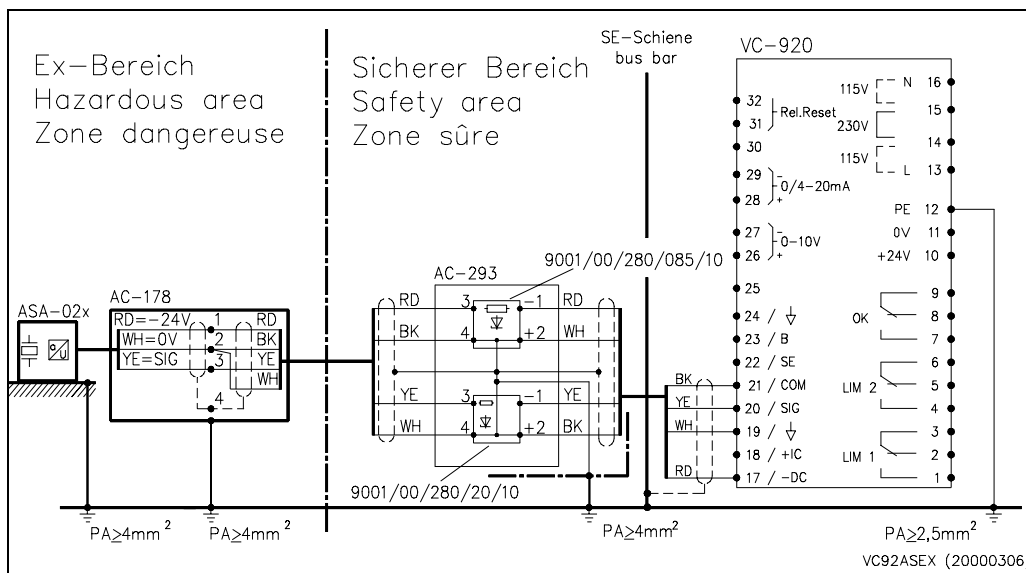

Vibration accelerometer in Ex- area (RD = red, WH = white, YE = yellow, BK = black)

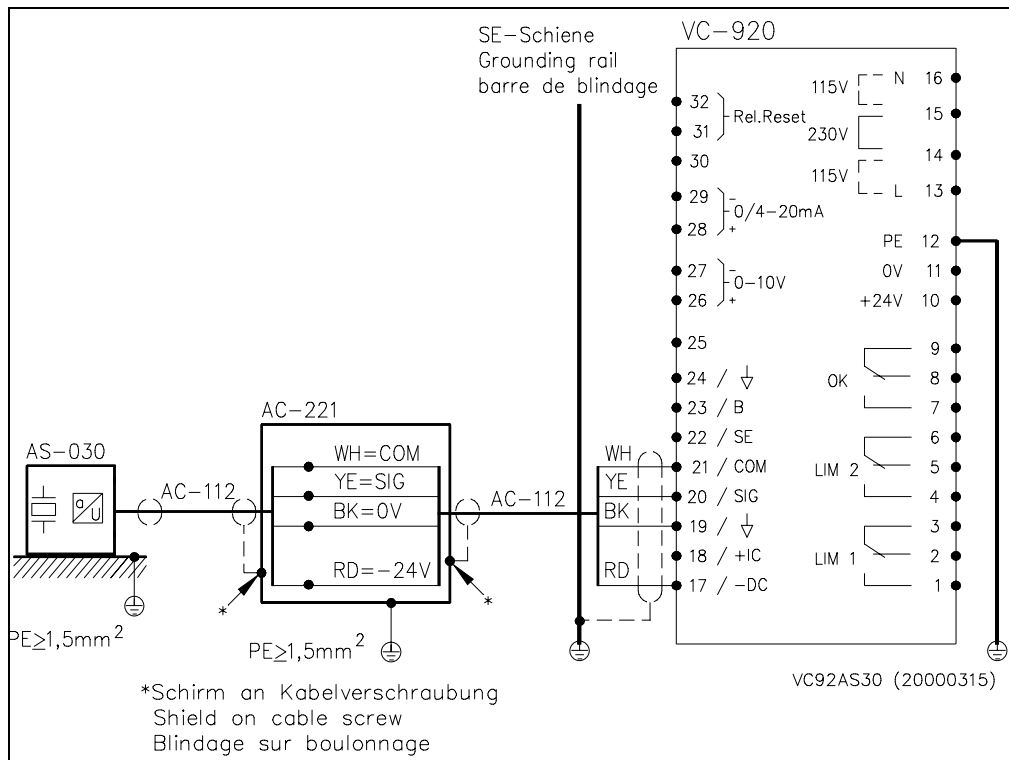

Vibration accelerometer; standard connection (WH = white, YE = yellow, RD = red)

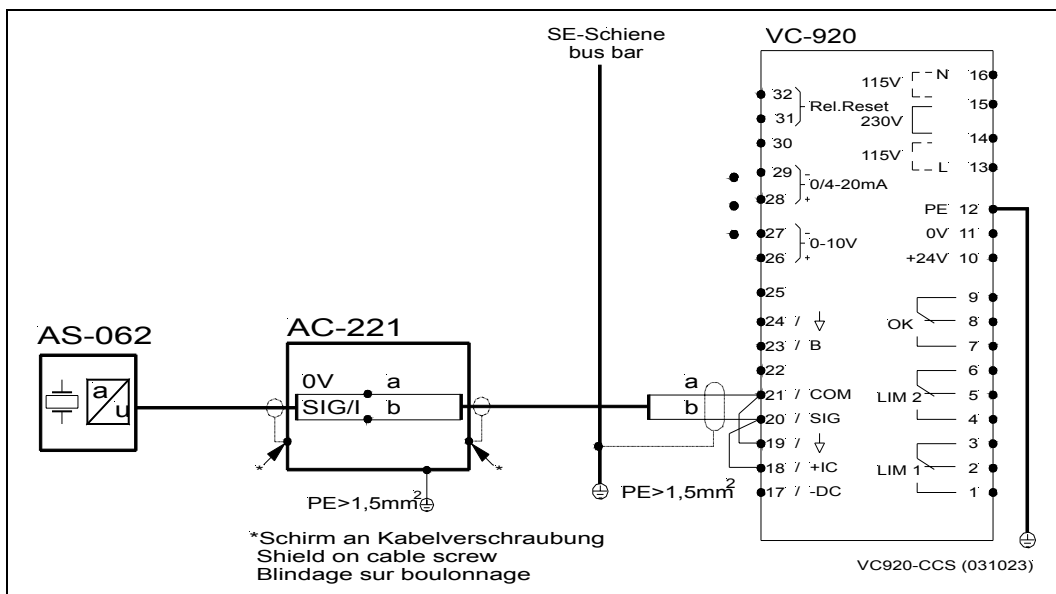

Vibration acceleration sensor with constant-current power requirement

Connection of constant-current sensors by a co-axial cable is not permitted.

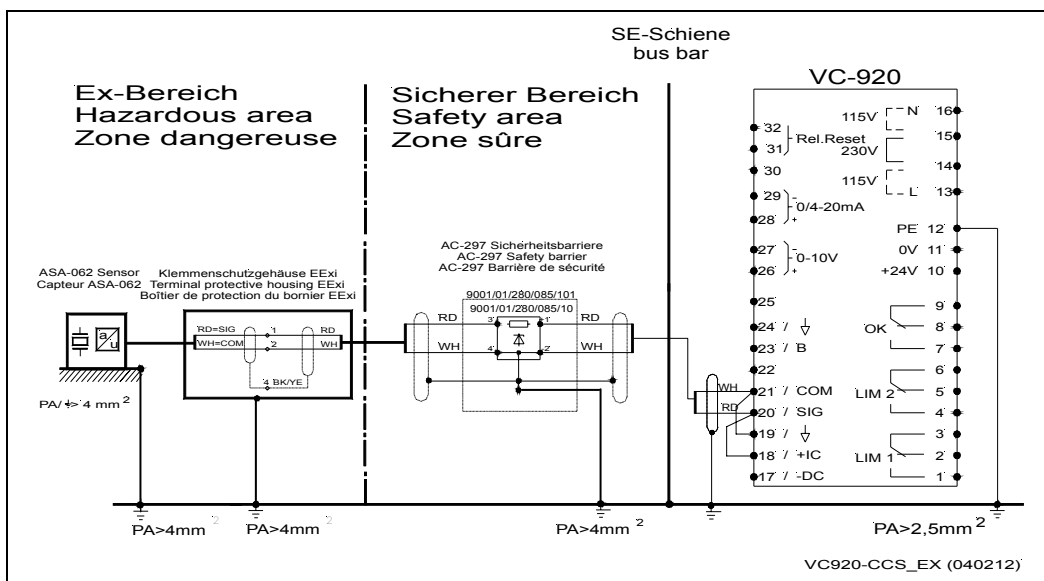

Vibration acceleration sensor with constant-current power requirement in hazardous area (RD = red, WH = white)

This page is for your notes.

8 Service

In accordance with general valid quality assurance measures the instrument should be subjected to testing, calibration and/or adjustment at regular intervals. This can be done either by the on-site service personnel, at the Brüel Kjær Vibro Ltd manufacturing facility or at one of the authorized Brüel Kjær Vibro service stations. An inspection of this type is recommended at intervals of 5 years.

The time interval at which the calibration constants of the instrument should be subjected to automatic correction is 12 months.

9 Instrument versions

Version < 2.8

Filter settings

The value for the lower filter frequency amounts to 3 Hz resp. 10 Hz

Conduct at switch-on

During the self-test after switch-on or return of power, the OK relay and limit relays will be in the de-energized condition.

Version < 3.0

Full scale changes

If the full scale value

- Parameter group 1 Mode 2-
changes, the defined limit values
 - LIM 1: Group 1 Mode 3 and
 - LIM 2: Group 1 Mode 4
- are retained.

Analog output test

Selecting the analog output test function

- Parameter group 2 Mode 7 / 4 -
switched an AC voltage of 5 V and 195 Hz to the diagnostic output.

10 Parameter list

Instrument number

Measurement point

.....

.....

Parameter Group 1

Mode 2	Range assignment for analog output	mm/s
Mode 3	Limit value LIM 1	mm/s
Mode 4	Limit value LIM 2	mm/s
Mode 5	Time delay LIM 1	s
Mode 6	Time delay LIM 2	s
Mode 7	High-pass filter value	Hz

Parameter Group 2

Mode 2	Sensor sensitivity	
Mode 3	Correction factor	
Mode 4	DC Current output range	mA
Mode 5	Limit relay operating mode	
Mode 6	LED display	
Mode 7	Analog outputs	

Parameter Group 3

Mode 2	Sensor power	V
Mode 3	Internal voltage 5 Volt	V
Mode 4	Internal voltage 17 Volt	V
Mode 5	Housing internal temperature	°C
Mode 6	Input amplifier factor	*
Mode 7	Output of D/A converter	*

* The value is dependent on the actual input signal.

This page is for your notes.