

WSU/WEU26-3

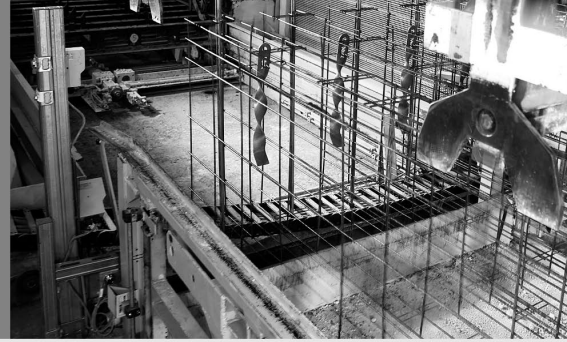

Single-beam Photoelectric Safety Switch



en

This document is protected by the law of copyright, whereby all rights established therein remain with the company SICK AG. Reproduction of this document or parts of this document is only permissible within the limits of the legal determination of Copyright Law. Alteration or abridgement of the document is not permitted without the explicit written approval of the company SICK AG.



Contents

Contents

1	About this document.....	5
1.1	Function of this document.....	5
1.2	Target group	5
1.3	Scope.....	5
1.4	Depth of information	5
1.5	Abbreviations.....	6
1.6	Terminology, symbols used.....	6
2	On safety.....	7
2.1	Qualified safety personnel.....	7
2.2	Applications of the device.....	7
2.3	Correct use	8
2.4	General safety notes and protective measures.....	8
2.5	Environmental protection	9
2.5.1	Disposal.....	9
2.5.2	Separation of materials.....	9
3	Product description.....	10
3.1	Special features.....	10
3.2	Operating principle of the device.....	10
3.2.1	Scanning range	10
3.2.2	Restart interlock.....	11
3.2.3	External device monitoring (EDM)	11
3.2.4	Front screen heating	11
3.3	Structure and function.....	11
3.4	Application example	13
4	Mounting	14
4.1	Preparation for mounting.....	14
4.1.1	Safety distance for access protection	14
4.1.2	Minimum distance to reflective surfaces	16
4.1.3	Mutual interference of systems in close proximity	17
4.2	Mechanical mounting.....	18
4.2.1	Deflector mirror	19
5	Electrical installation.....	22
5.1	Important information for the installation.....	22
5.2	System connection	22
5.2.1	Pin assignment sender.....	22
5.2.2	Tested.....	23
5.2.3	Pin assignment receiver	23
5.3	Arc-suppression.....	25
5.4	Cross-circuit monitoring.....	25
5.5	Overcurrent protection (fuse).....	25
6	Commissioning.....	26
6.1	Aligning sender and receiver	26
6.1.1	Alignment using the diagnostics LEDs	26
6.1.2	Alignment using the AR60 laser alignment aid	27
6.2	Test notes.....	28
6.2.1	Tests before the initial commissioning.....	28
6.2.2	Daily functional checks of the protective device	28

6.2.3	Regular inspection of the protective device by qualified safety personnel	29
7	Care and maintenance	30
8	Fault diagnosis	31
8.1	In the event of faults or errors	31
8.2	SICK support	31
8.3	Status displays of the diagnostics LEDs	31
9	Technical specifications.....	33
10	Ordering information	36
10.1	Devices	36
10.2	Deflector mirror.....	36
10.3	Accessories	36
10.4	Dimensional drawings.....	37
11	Annex	40
11.1	Compliance with EU directives.....	40
11.2	Checklist for the manufacturer	41
11.3	List of tables	42
11.4	List of illustrations.....	42

1 About this document

Please read this chapter carefully before you work with these operating instructions and the WSU/WEU26-3 single-beam photoelectric safety switches, referred to in the following as WSU/WEU26-3 devices.

1.1 Function of this document

These operating instructions are designed to address the technical personnel of the machine manufacturer or the machine operator in regards to safe mounting, installation, configuration, electrical installation, commissioning, operation and maintenance of the WSU/WEU26-3 devices.

These operating instructions do not provide instructions for operating machines on which the WSU/WEU26-3 devices are, or will be, integrated. Information on this is to be found in the appropriate operating instructions for the machine.

1.2 Target group

These operating instructions are addressed to planning engineers, machine designers and operators of plants and systems which are to be protected by the WSU/WEU26-3 devices. They are also addressed to people who integrate the WSU/WEU26-3 devices into a machine, initialise its use, or who are in charge of servicing and maintaining the device.

1.3 Scope

These operating instructions are original operating instructions.

These operating instructions are only applicable to the WSU/WEU26-3 single-beam photoelectric safety switch with one of the following entries on the type label in the field *Operating Instructions*:

- 8013336
- 8013336/YTA4
- 8013336/1BJE

This document is part of SICK part number 8013336 (operating instructions “WSU/WEU26-3 single-beam photoelectric safety switch” in all available languages).

1.4 Depth of information

These operating instructions contain the following information on the WSU/WEU26-3 devices:

- mounting,
- electrical installation,
- commissioning,
- application,
- error diagnosis and troubleshooting,
- part numbers,
- conformity and approval,
- care and maintenance.

Planning and using protective devices such as the WSU/WEU26-3 devices also require specific technical skills which are not detailed in this documentation.

When operating the WSU/WEU26-3 devices, the national, local and statutory rules and regulations must be observed.

General information on accident prevention using opto-electronic protective devices can be found in the brochure “Guidelines Safe Machinery – Six steps to the safe machine”.

Note We also refer you to the SICK homepage on the Internet at www.sick.com.

Here you will find information on:

- sample applications,
- these operating instructions in different languages for viewing and printing,
- EU declaration of conformity and other documents.

1.5 Abbreviations

EDM	External device monitoring
ESD	Electro-static discharge
ESPE	Electro-sensitive protective equipment
LED	Light Emitting Diode
OSSD	Output signal switching device

1.6 Terminology, symbols used

Recommendation Recommendations are designed to give you some assistance in your decision-making process with respect to a certain function or a technical measure.

Note Refer to notes for special features of the device.

● **Red**, ● **Yellow**, LED symbols describe the state of a diagnostics LED. Examples:

- **Green** ● **Red** The red LED is illuminated constantly.
- **Yellow** The yellow LED is flashing.
- **Green** The green LED is off.

➤ **Take action ...** Instructions for taking action are shown by an arrow. Read carefully and follow the instructions for action.



WARNING



Warning!

A warning notice indicates an actual or potential risk or health hazard. They are designed to help you to prevent accidents.

Read carefully and follow the warning notices!



Sender and receiver

In drawings and diagrams, the symbol  denotes the sender and the symbol  denotes the receiver.

The term “dangerous state”

The dangerous state (standard term) of the machine is always shown in the drawings and diagrams of this document as a movement of a machine part. In practical operation, there may be a number of different dangerous states:

- machine movements,
- electrical conductors,
- visible or invisible radiation,
- a combination of several risks and hazards.

2 On safety

This chapter deals with your own safety and the safety of the equipment operators.

➤ Please read this chapter carefully before working with the WSU/WEU26-3 devices or with the machine protected by the WSU/WEU26-3 devices.

2.1 Qualified safety personnel

The WSU/WEU26-3 devices must be mounted, commissioned and serviced only by qualified safety personnel. Qualified safety personnel are defined as persons who

- have undergone the appropriate technical training
- and
- who have been instructed by the responsible machine operator in the operation of the machine and the current valid safety guidelines
- and
- who have access to these operating instructions.

2.2 Applications of the device

The WSU/WEU26-3 devices are electro-sensitive protective equipment (ESPE), type 4 in accordance with IEC 61496-1 and IEC 61496-2 and may for this reason be used in controllers of safety category 4 in accordance with EN ISO 13849, SILCL3 in accordance with EN 62061 or up to PL e in accordance with EN ISO 13849. The WSU/WEU26-3 devices are used for:

- hazardous area protection,
- access protection.

The photoelectric switch must be installed such that the hazardous area can only be reached by interrupting the light path between sender and receiver. It must not be possible to start the plant/system as long as personnel are within the hazardous area.

The WSU/WEU26-3 devices are intended only for use in industrial environments. When used in residential areas it can cause radio interferences.

Please refer chapter 3.4 on page 13 for an illustration of the protection mode and an example application.



WARNING

Only use the WSU/WEU26-3 devices as an indirect protective measure!

Opto-electronic protective devices as the WSU/WEU26-3 devices cannot provide any protection against parts thrown out or against radiation. Transparent objects are not detected.

Depending on the application, mechanical protective devices may be required in addition to the WSU/WEU26-3 devices.

2.3 Correct use

The WSU/WEU26-3 devices may only be used as specified in chapter 2.2 “Applications of the device”. They are only allowed to be used by qualified safety personnel and only on the machine on which they have been installed and initialised by qualified safety personnel as per these operating instructions.

All warranty claims against SICK AG are forfeited in the case of any other use, or alterations being made to the WSU/WEU26-3 devices, even as part of their mounting or installation.

2.4 General safety notes and protective measures



WARNING

Safety notes

Please observe the following items in order to ensure the correct and safe use of the WSU/WEU26-3 devices.

- National/international rules and regulations apply to the installation, commissioning, use and periodic technical inspections of the WSU/WEU26-3 devices, in particular:
 - Machinery Directive,
 - Work Equipment Directive,
 - the work safety regulations/safety rules,
 - other relevant safety regulations.
- Manufacturers and operators of the machine on which the WSU/WEU26-3 devices are used are responsible for obtaining and observing all applicable safety regulations and rules.
- It is imperative the test notes from page 28 of these operating instructions (“Tests before the first commissioning”, “Daily functional checks of the protective device”, “Regular inspection of the protective device by qualified safety personnel”) are followed.
- The tests must be carried out by qualified safety personnel or specially qualified and authorised personnel and must be recorded and documented to ensure that the tests can be reconstructed and retraced at any time.
- The operating instructions must be made available to the operator of the machine where the WSU/WEU26-3 devices are used. The machine operator is to be instructed in the use of the device by qualified safety personnel and must be instructed to read the operating instructions.
- The external voltage supply for the devices must be capable of buffering brief mains voltage failures of 20 ms as specified in EN 60204. Suitable power supplies are available as accessories from SICK.
- A safety extra-low voltage SELV/PELV must be used to supply power to the WSU/WEU26-3 devices.

2.5 Environmental protection

The WSU/WEU26-3 devices are constructed in such a way that they adversely affect the environment as little as possible. The devices use only a minimum of power and natural resources.

At work, always act in an environmentally responsible manner. For this reason please note the following information on disposal.

2.5.1 Disposal

- Always dispose of unserviceable or irreparable devices in compliance with local/national rules and regulations with respect to waste disposal.

Note We would be pleased to be of assistance on the disposal of this device. Contact your local SICK representative.

Information on the individual materials in the WSU/WEU26-3 is given in chapter 9 “Technical specifications” from page 33.

2.5.2 Separation of materials



WARNING

Only appropriately trained personnel are allowed to separate materials!

Caution is required when dismantling devices. There is a risk of injuries.

Before you send the devices for appropriate recycling, it is necessary to separate the different materials in the WSU/WEU26-3 devices.

- Separate the housing from the rest of the parts (in particular the circuit board).
- Send the separated parts for recycling as appropriate (see Tab. 1).

Tab. 1: Overview on disposal by components

Components	Disposal
Product Housing Circuit boards, cable, connector and electrical connecting pieces	Metal recycling (aluminium) Electronic recycling
Packaging Cardboard, paper Polyethylene packaging	Paper/cardboard recycling Plastic recycling

3 Product description

This chapter provides information on the special features, the operating principle, the structure and the function of the WSU/WEU26-3 devices.

➤ Please read this chapter before mounting, installing and commissioning the WSU/WEU26-3 devices.

3.1 Special features

- relay outputs
- rugged type of construction
- high operating range up to 70 m
- front screen heating

3.2 Operating principle of the device

The single-beam photoelectric safety switch consists of a WSU26-3 sender unit and a WEU26-3 receiver. The sender unit WSU26-3 emits a beam of light that is received by the receiver unit WEU26-3.

Fig. 1: Key data for the WSU/WEU26-3 devices

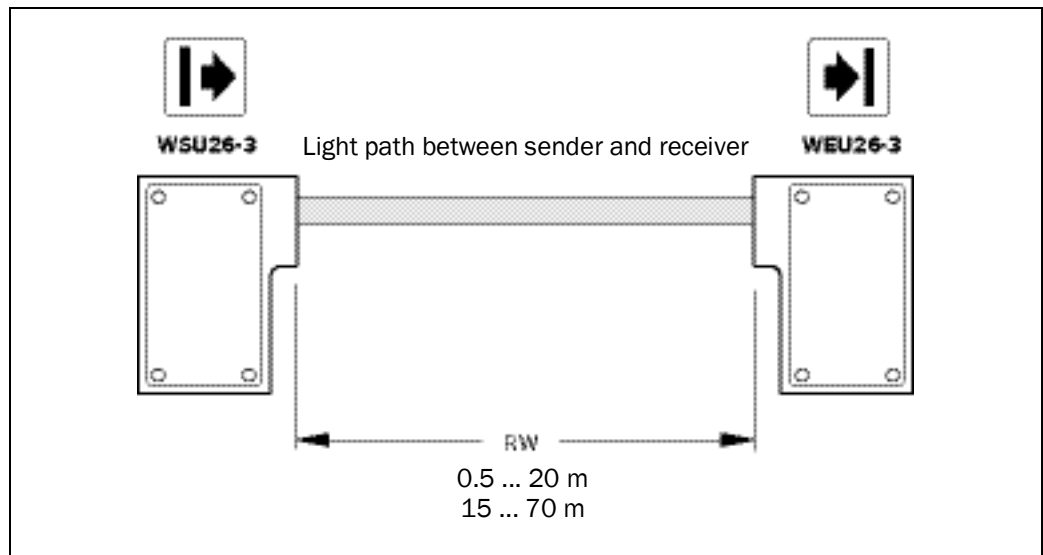

If the light beam is interrupted by an object, a switching command is triggered. The machine or plant controller that evaluates this message must then bring the dangerous movement to a halt.

Sender and receiver units are equipped with LEDs for the operational check. Their function as diagnostic elements is described in chapter 6 “Commissioning”.

The diagnostics LEDs are used for fault diagnosis (see chapter 8 “Fault diagnosis”).

The WSU/WEU26-3 devices are not equipped with an internal restart interlock.

3.2.1 Scanning range



WARNING

Use the receiver with the permitted operating range to suit the length of the light path between the sender and receiver!

- If the operating range is too low, the single-beam photoelectric safety switch may not switch to green.
- If the operating range is too large, the single-beam photoelectric safety switch may malfunction due to reflections. This would mean that the operator is at risk.

Two receiver with different scanning ranges are available:

Tab. 2: Receiver variants

Receiver	Operating range
WEU26-3-103A00	0.5 ... 20 m
WEU26-3-203A00	15 ... 70 m

3.2.2 Restart interlock

The WSU/WEU26-3 devices do not have an internal restart interlock. It is only possible to implement a restart interlock for the machine externally. During this process the WSU/WEU26-3 devices have no control over the restart.

Note A restart interlock prevents the machine starting again after an error or an interruption of the light path.



WARNING

Always operate the application with restart interlock!

Ensure an external restart interlock is always activated on the machine. The WSU/WEU26-3 devices are unable to verify if the external restart interlock of the machine is operable. If you deactivate the external restart interlock, the operator of the machine will be at acute risk of injury.

3.2.3 External device monitoring (EDM)

The WSU/WEU26-3 devices do not have any feature for monitoring the downstream contactors. External device monitoring on the downstream contactors is only possible with an external circuit. You will find additional explanations on the connection of downstream contactors in chapter 5.2 "System connection".

Note An EDM checks if the downstream contactors actually de-energize when the protective device is tripped.

3.2.4 Front screen heating

Sender and receiver have front screen heating. The front screen heating counteracts the formation of droplets, mist, frost and ice.



WARNING

Ensure the optical properties of the front screen are not changed by the formation of droplets, mist, frost or ice, otherwise there will be a hazard for the operator.

3.3 Structure and function

The WSU/WEU26-3 devices are equipped with diagnostics LEDs:

Diagnostics LEDs of the sender

Fig. 2: Diagnostics LEDs
WSU26-3

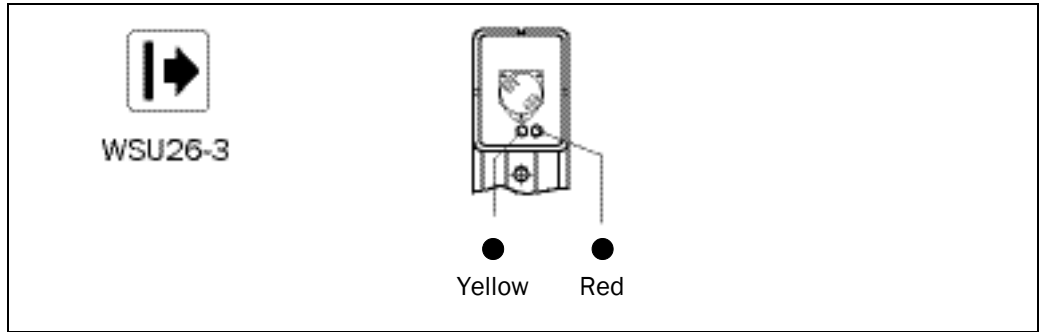

Tab. 3: Diagnostics LEDs WSU26-3

Display		Meaning
Yellow	Red	
●	○	Device on, test inactive
●	●	Device on, test active, test contacts open

Diagnostics LEDs of the receiver

Fig. 3: Diagnostics LEDs WEU26-3

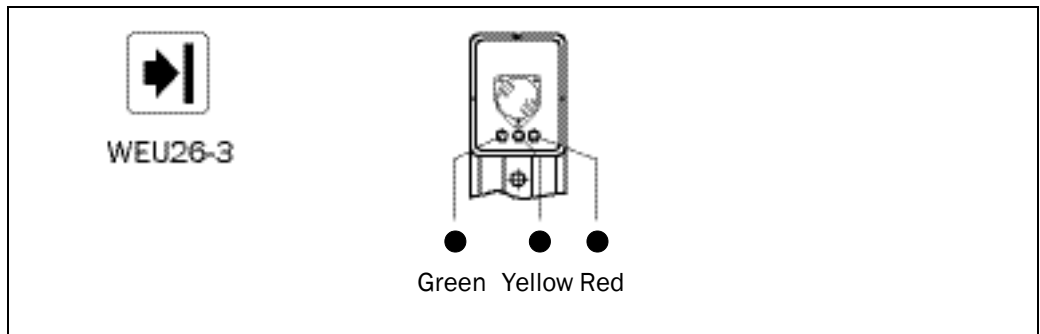

Tab. 4: Diagnostics LEDs WEU26-3

Display			Meaning
Green	Yellow	Red	
●	○	○	Output signal switching devices on, light path unoccupied
○	○	●	Output signal switching devices off, light path interrupted or inadequate alignment or device not yet ready after switch on (see technical specifications)
●	●	○	Output signal switching devices on, light path unoccupied, weak signal
○	●	●	Output signal switching devices off, light path interrupted or inadequate alignment. Prior to the complete interruption of the light path the signal was weak.

3.4 Application example

The WSU/WEU26-3 devices are used as access protection for hazardous areas on machines or systems (Fig. 4). The devices are permanently mounted in the access area with the necessary safety distance from the nearest hazardous point. If the light beam is interrupted by an object, a switching command is triggered. The machine or plant controller that evaluates this message must then bring the dangerous movement to a halt.

Fig. 4: Access guarding with WSU/WEU26-3

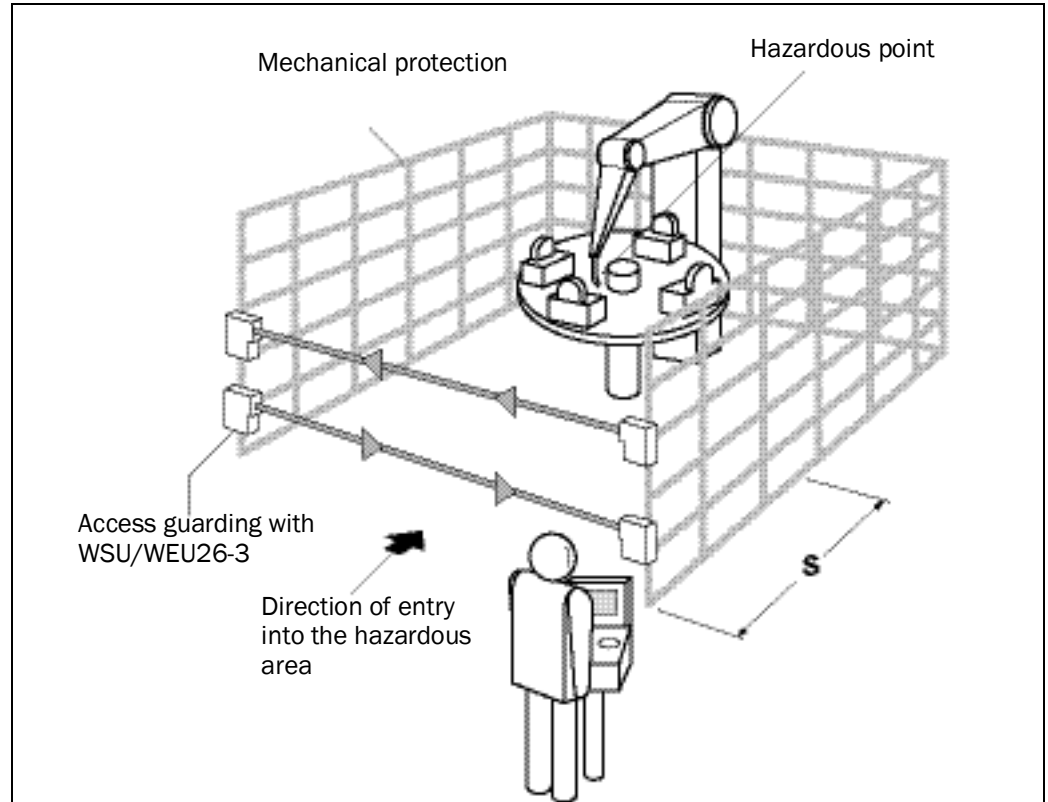

4 Mounting

This chapter describes the preparation and completion of the installation of the WSU/WEU26-3 devices:

- calculating the necessary safety distance,
- calculating the distance from reflective surfaces,
- mounting the device.

The following steps are necessary after mounting:

- complete the electrical connections (chapter 5),
- alignment of senders and receivers (chapter 6.1),
- testing the installation (chapter 6.2).



WARNING

No protective function without sufficient safety distance!

The reliable protective effect of the single-beam photoelectric safety switches depends on the WSU/WEU26-3 devices being mounted with the correct safety distance from the hazardous point.

4.1 Preparation for mounting

4.1.1 Safety distance for access protection

A safety distance must be maintained between the protective field and the hazardous point. This safety distance ensures that the hazardous point can only be reached after the dangerous state of the machine has been completely stopped.

The safety distance as per EN ISO 13855 and EN ISO 13857 depends on:

- stopping/run-down time of the machine or system (The stopping/run-down time is shown in the machine documentation or must be determined by taking a measurement.),
- response time of the entire protective device,
- reach or approach speed,
- number of beams/beam separation.

Under the authority of OSHA and ANSI the safety distance as specified by ANSI B11.19 (Annex D) E.4.2.3.3.5 and Code of Federal Regulations, Volume 29, Part 1910.217 ... (h) (9) (v) depends on:

- stopping/run-down time of the machine or system (The stopping/run-down time is shown in the machine documentation or must be determined by taking a measurement.),
- response time of the entire protective device,
- reach or approach speed,
- other parameters that are stipulated by the standard depending on the application.

Fig. 5: Safety distance S to the light beam

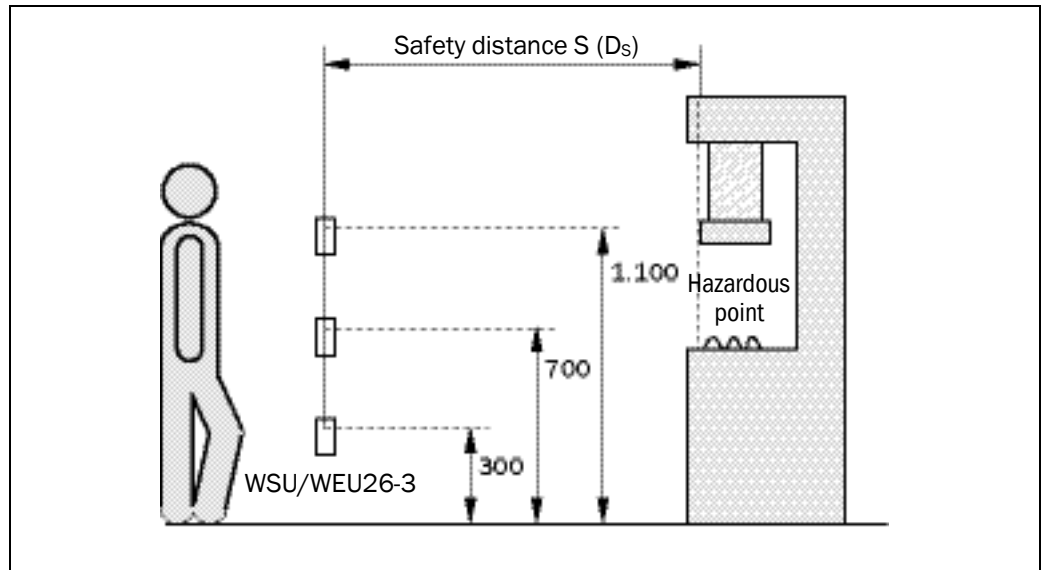

How to calculate the safety distance S according to EN ISO 13855 and EN ISO 13857:

Note The following calculation shows an example calculation of the safety distance. Depending on the application and the ambient conditions, a different calculation may be necessary.

➤ First, calculate S using the following formula:

$$S = K \times T + C \text{ [mm]}$$

Where ...

T = Stopping/run-down time of the machine + response time of the WSU/WEU26-3 devices after light path interruption [s]

S = Safety distance [mm]

K = Approach speed 1.6 [m/s]

C = Depending on the number of beams (1, 2, 3 or 4), see Tab. 5

Tab. 5: Height of the beams above the floor

Number of beams	1	2	3	4
Height of the beams above the floor [mm]	750	400 900	300 700 1,100	300 600 900 1,200
C	1,200	850	850	850

Example:

Access guarding with two beams C = 850 mm

Stopping/run-down time of the machine = 290 ms

Response time after light path interruption = 22 ms

Approach speed = 1.6 m/s

$$T = 290 \text{ ms} + 22 \text{ ms} = 312 \text{ ms} = 0.31 \text{ s}$$

$$S = 1,600 \times 0.31 + 850 = 1,346 \text{ mm}$$

How to calculate the safety distance Ds according to ANSI B11.19 (Annex D)

E.4.2.3.3.5 and Code of Federal Regulations, Volume 29, Part 1910.217 ... (h) (9) (v):

Note

The following calculation shows an example calculation of the safety distance. Depending on the application and the ambient conditions, a different calculation may be necessary.

➤ First, calculate D_s using the following formula:

$$D_s = H_s \times (T_s + T_c + T_r + T_{bm}) + D_{pf}$$

Where ...

D_s = The minimum distance in inches (or millimetres) from the hazardous point to the protective device

H_s = A parameter in inches/second or millimetres/second, derived from data on approach speeds of the body or parts of the body. Often 63 inches/second is used for H_s .

T_s = Stopping/run down time of the machine tool measured at the final control element

T_c = Stopping/run-down time of the control system

T_r = Response time of the entire protective device after light path interruption

T_{bm} = Additional response time allowed for brake monitor to compensate for wear

Note Any additional response times must be accounted for in this calculation.

D_{pf} = An additional distance added to the overall safety distance required. This value is based on intrusion toward the hazardous point prior to actuation of the electro-sensitive protective equipment (ESPE). For applications that can be reached over, the value $D_{pf} = 1.2$ m. For beam arrangements that permit reaching in with the arms or the detectable object size is greater than 63 mm, the value $D_{pf} = 0.9$ m.



WARNING

Maintain the safety distance!

The WSU/WEU26-3 devices are to be fitted such that when the light beam is interrupted, the hazardous point is only reached when the dangerous state is no longer present.



WARNING

Risk of failure to detect!

Persons who are in the hazardous area but not in the light path between sender and receiver are not detected by the WSU/WEU26-3 devices. It is therefore to be ensured that the hazardous area is fully visible and any dangerous state can only be initiated if there are no personnel in the hazardous area.

The WSU/WEU26-3 devices are not allowed to be used for hand and finger protection.

The applicable legal and official regulations apply to the use and mounting of the protective device. These regulations vary depending on the application.

4.1.2 Minimum distance to reflective surfaces

The light beams from the sender may be deflected by reflective surfaces. This can result in failure to identify the object.

Therefore all reflective surfaces and objects (e.g. material bins) must be a minimum distance a from the light path between sender and receiver of the WSU/WEU26-3 devices. The minimum distance a depends on the distance D between sender and receiver.

Fig. 6: Minimum distance to reflective surfaces

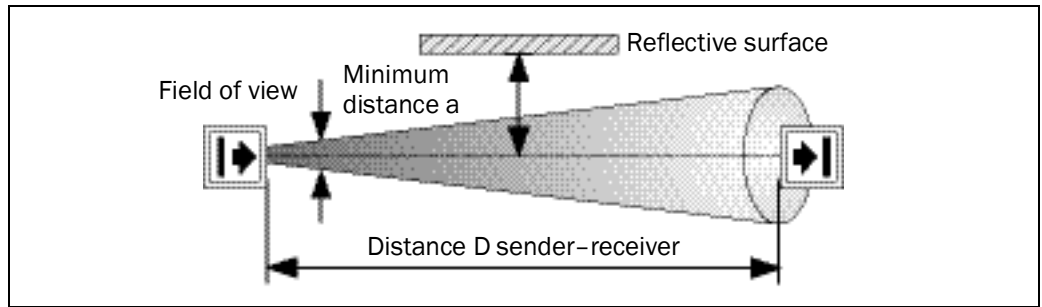

Note Sender and receiver optics have the same field of view.



WARNING

The minimum distances to reflective surfaces only apply when the light path is clear. On the usage of transparent guard windows, these values may change.

Fig. 7: Graph, minimum distance from reflective surfaces

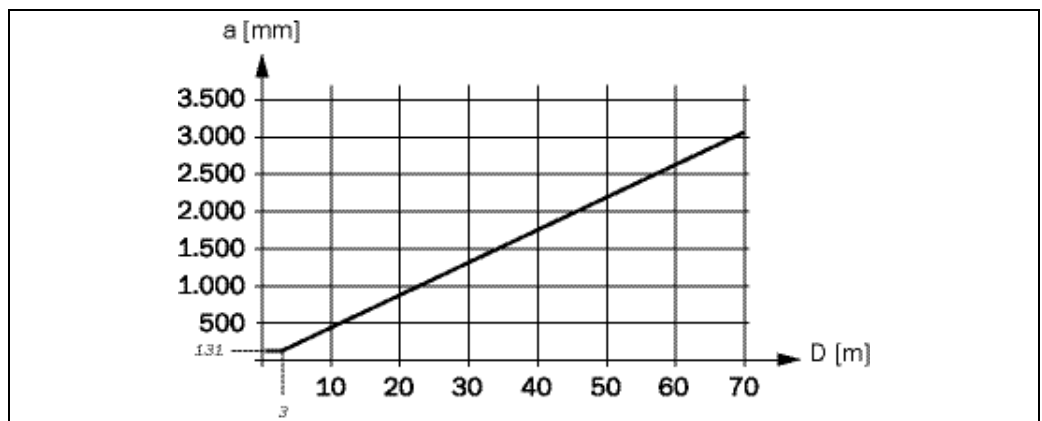

Tab. 6: Formula for the calculation of the minimum distance to reflective surfaces

Distance D [m] sender – receiver	Calculation of the minimum distance a from reflective surfaces
$D \leq 3 \text{ m}$	$a \text{ [mm]} = 131$
$D > 3 \text{ m}$	$a \text{ [mm]} = \tan(2.5^\circ) \times 1,000 \times D \text{ [m]} = 43.66 \times D \text{ [m]}$

4.1.3 Mutual interference of systems in close proximity



WARNING

Prevent the mutual interference of systems mounted in close proximity!

If several WSU/WEU26-3 devices operate in close physical proximity, the sender beams from one device may interfere with the receiver for another device such that the protective function of the different WSU/WEU26-3 devices is no longer ensured and there is a hazard for the operator. You must avoid such mounting scenarios or take appropriate measures, e.g. by mounting non-reflective sight protection walls or by reversing the transmission direction of a device.

Fig. 8: Mounting two WSU/WEU26-3 devices in series

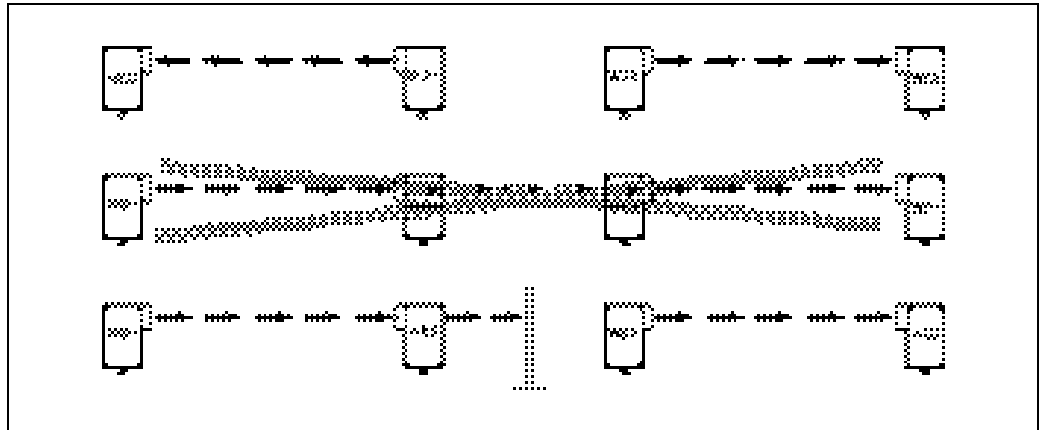

4.2 Mechanical mounting

WSU26-3 and WEU26-3 are to be mounted to suit the local conditions on one of the sides of their housing or using the mounting bracket. The mounting bracket significantly eases alignment. The device can be operated in any position. WSU26-3 and WEU26-3 are, however, to be mounted such that the axis of the beam emitted by the WSU26-3 is always aligned with the axis of the WEU26-3 optics (alignment sight, see Fig. 18, page 27).

Note The mounting brackets are to be attached such that all fixing screws are easily accessible for alignment. Fig. 9 shows examples. The devices are to be attached such that it is possible to align with the related device opposite using the alignment sight.

Fig. 9: Mounting possibilities using mounting brackets

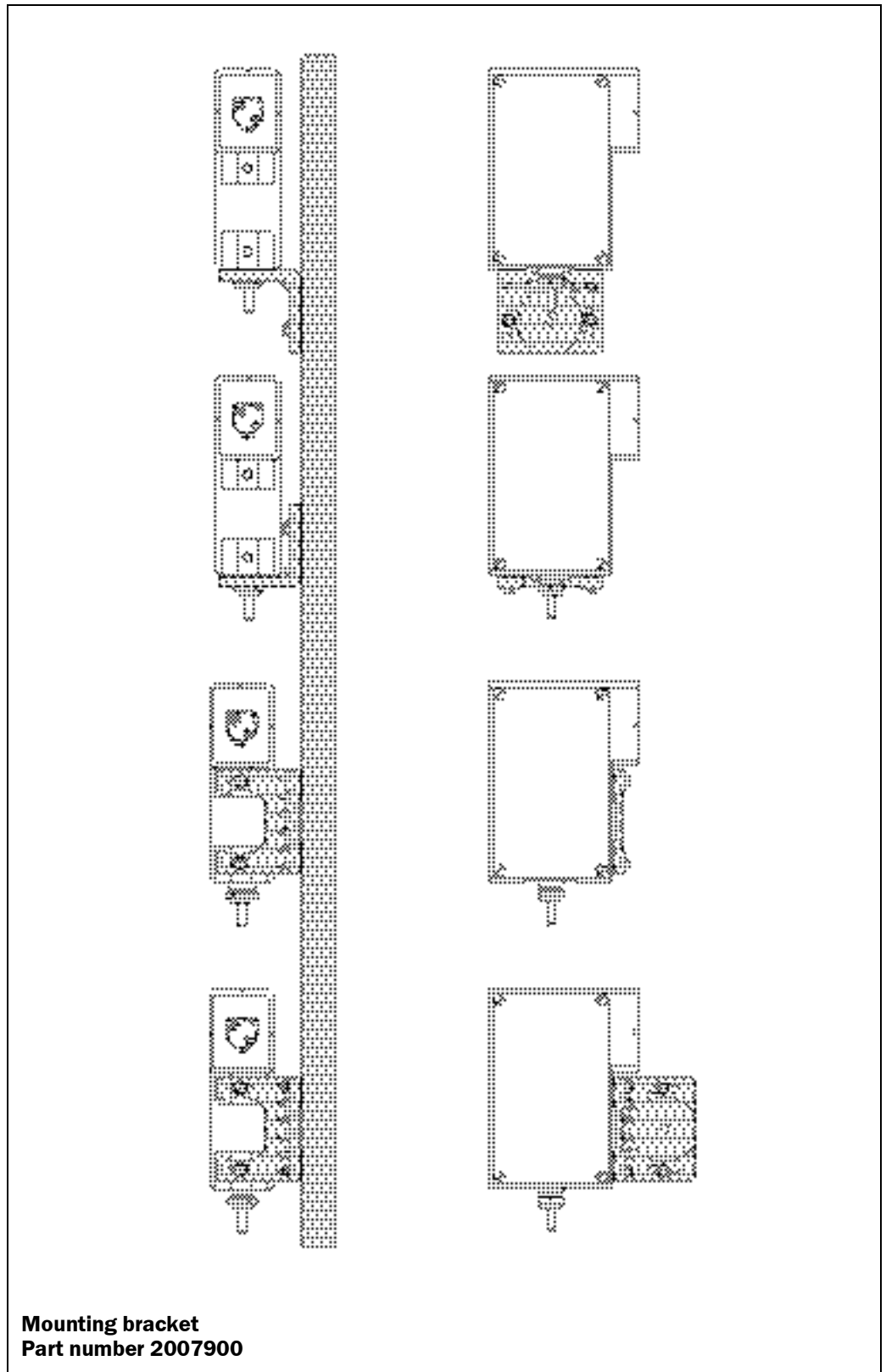

4.2.1 Deflector mirror

With the WSU/WEU26-3 and deflector mirrors, access protection on several sides can be realised (Fig. 10).

Note

The usage of deflector mirrors reduces the effective scanning range of the system WSU/WEU26-3 as specified in Tab. 7.

Note The usage of mirrors (Fig. 11) requires very precise alignment. It is recommended to use the AR60 laser alignment aid. The AR60 alignment aid is available as an accessory (Tab. 17, page 36).

Tab. 7: Reduction in the scanning range on the usage of deflector mirrors with $\alpha = 90^\circ$

Number of mirrors	WEU26-3 with short scanning range	WEU26-3 with long scanning range
1	0.5 ... 18 m	14.2 ... 63 m
2	0.5 ... 16 m	13.5 ... 56 m
3	0.5 ... 14.3 m	12.8 ... 50 m
4	0.5 ... 12.8 m	12.2 ... 45 m

Fig. 10: Hazardous area protected on several sides

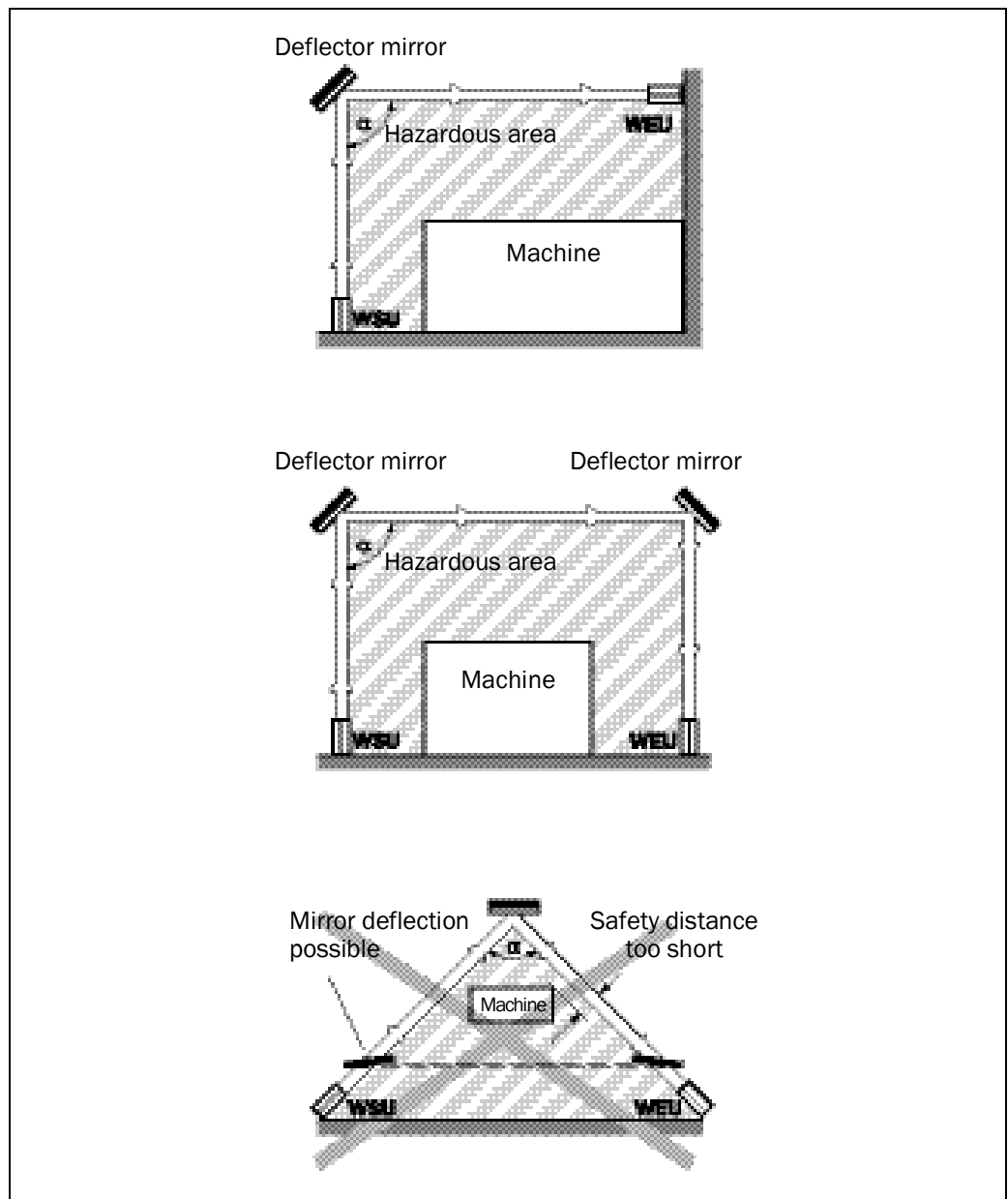
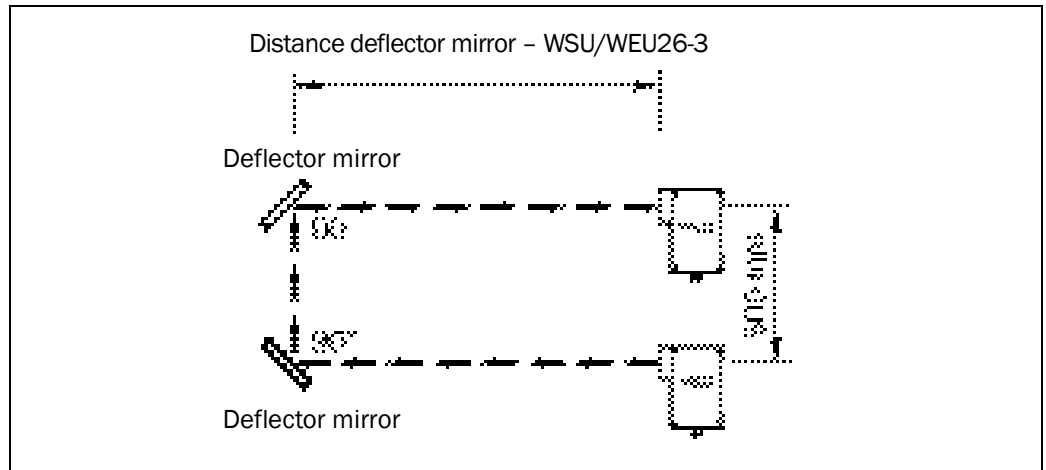

Fig. 11: Two-beam protection with one system WSU/WEU26-3



Tab. 8: Distances of the deflector mirrors

WEU26-3 receiver	Distance deflector mirror - WSU/WEU26-3
Low scanning range	0.5 ... 7.5 m
High scanning range	> 7.5 m

Note If there are reflective surfaces in the area of the light path between the sender and receiver or such surfaces may occur, the alignment of the system must be adjusted: Sender and receiver must always be aligned such that there are no reflecting surfaces in the area of the field of view (see Fig. 13).

Fig. 12: Incorrect alignment of sender and receiver

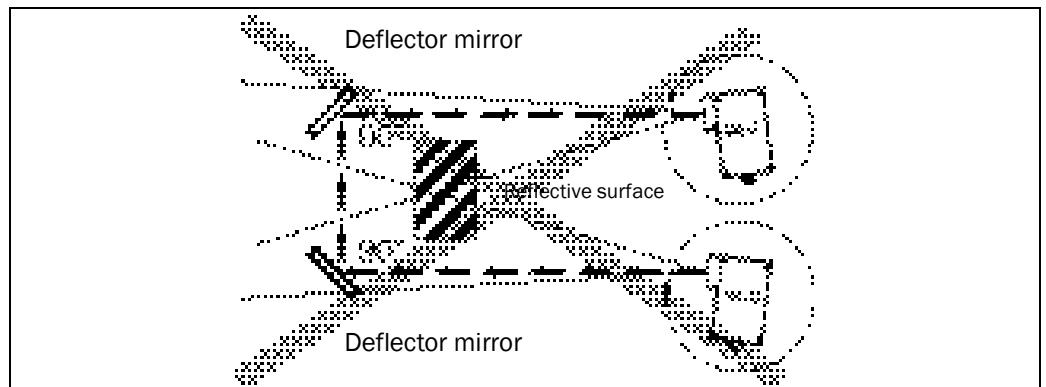
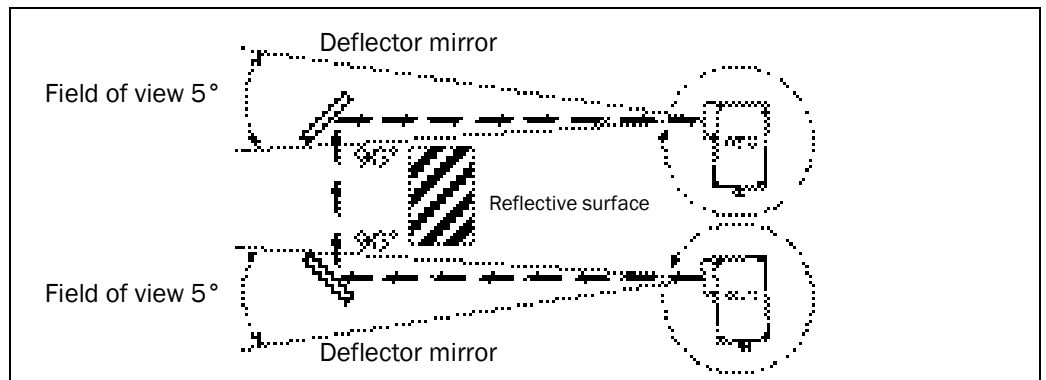

Fig. 13: Correct alignment of sender and receiver



5 Electrical installation

5.1 Important information for the installation



WARNING

Switch the entire machine/system off line!

The machine/system could inadvertently start up while you are connecting the devices. Ensure that the entire machine/system is disconnected during the electrical installation.

Notes:

- The WSU/WEU26-3 single-beam photoelectric safety switch meets the interference suppression requirements (EMC) for industrial use (interference suppression class A). When used in residential areas it can cause interference.
- A safety extra-low voltage SELV/PELV must be used to supply power to the WSU/WEU26-3 devices.
- The external voltage supply must bridge a brief mains failure of 20 ms (EN 60204). Suitable power supplies are available as accessories from SICK.
- Prior to opening the cover (see chapter 10.4 “Dimensional drawings”) all cables for the supply voltage and the relay connections must be electrically isolated.
- Only open the device with appropriate protection against ESD, i.e. pay attention to earthing. In the device only touch the connection terminals, not the other parts of the electronics. All work on the open device is only allowed to be undertaken by qualified safety personnel.
- If the cover is open, the device does not provide any protective function.
- The connecting cables must be laid directly to the terminal strip.
- After mounting, the firm seating of the connecting cables in the connection terminals must be checked.
- Observe torque figure for the protective conductor connection (“PE”) (see chapter 5.2 “System connection”, Tab. 9/Tab. 10, Fig. 14/Fig. 15).
- On the installation of another PG connector, it is necessary to comply with the torque data for the PG connector (see chapter 10.4 “Dimensional drawings”).
- Prior to screwing in place the cover, the seal must be checked for contamination and damage. Fasten the cover to the related torque (see chapter 10.4 “Dimensional drawings”).
- After opening the cover, the complete commissioning function test must be performed (see chapter 6 “Commissioning”).

5.2 System connection

5.2.1 Pin assignment sender

Tab. 9: Assignment of the sensor contacts, sender WSU26-3

WSU/WEU26-3

Pin	Designation
1/2	Voltage supply 24 V DC
3	Ground 0 V
10	Test contacts
11	
PE	Protective earth

Note The torque for the PE connection is 2.0 ± 0.5 Nm.

Note The single-beam photoelectric safety switch is also available with an 8-pin M12 male connector, see chapter 10.1 „Devices“.

Note Connect the contacts on the WSU26-3 only to circuits that comply with the requirements for safety extra-low voltage (SELV/PELV).

Fig. 14: Assignment of the sensor contacts, sender WSU26-3

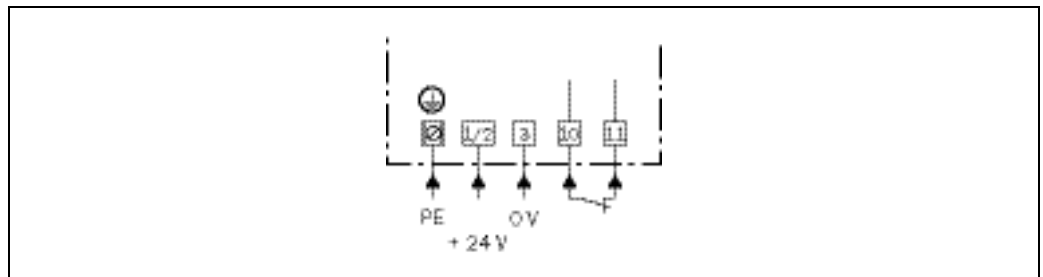

5.2.2 Tested

The test makes it possible to check the loads connected. For this purpose the electrical connection between test contacts 10 and 11 on the WSU26-3 is interrupted for a certain amount of time (see chapter 9 “Technical specifications”). As a result the sender does not emit a beam of light and simulates an interruption to the light path.

The test must be performed by the machine controller during the unhazardous phase (e.g. an unhazardous movement). If the test is not successful, the machine must receive a shut down signal from the machine controller.

Note To operate the WSU/WEU26-3 devices without testing, a wire jumper must be connected between the test contacts 10 and 11 on the WSU26-3.



WARNING

Use test function for the purpose described!

The test input is only allowed to be used in the manner described.

5.2.3 Pin assignment receiver

Tab. 10: Assignment of the sensor contacts, receiver WEU26-3

Pin	Designation
1/2	Voltage supply 24 V DC
3	Ground 0 V
4	Safety relay, normally open contact
5	
6	Safety relay 1/2, normally closed contacts connected in parallel internally
7	
8	Safety relay 2, normally open contact
9	
PE	Protective earth

Both normally open contacts are to be used for safety-related functions. In a subsequent dual-channel circuit the two normally open outputs are to be connected to a safety controller with a suitable level of safety (see Fig. 15).

The normally closed contacts are not allowed to be used for safety-related functions.

If the downstream logic is realised using discrete contactors, they must be positively guided and externally monitored. The monitoring cannot be provided by the WEU26-3.

Note The torque for the PE connection is 2.0 ± 0.5 Nm.

Fig. 15: Assignment of the sensor contacts, connection diagram WEU26-3 on UE43

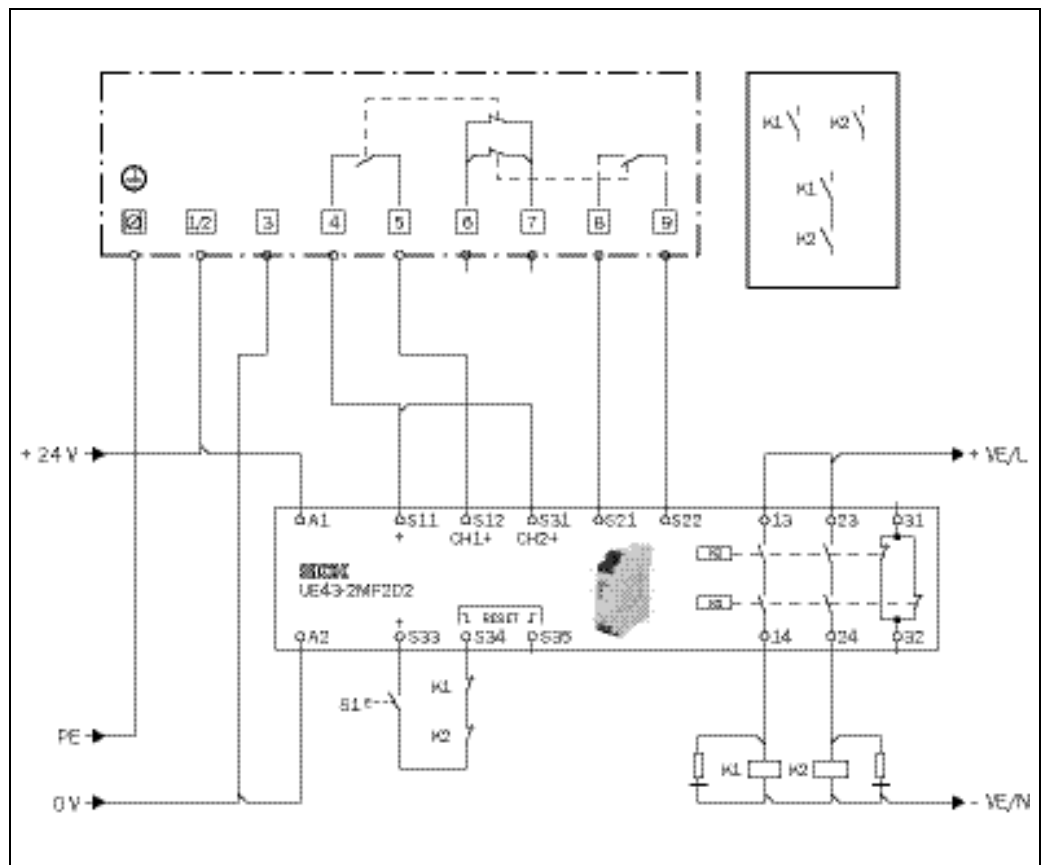

Note The cross-circuit monitoring on the connecting cables between the normally open contacts 4 and 5 or 8 and 9 on the WEU26-3 is provided by the safety controller UE43.

5.3 Arc-suppression



WARNING

In case of an inductive load: Use arc-suppression elements!

Suitable arc-suppressors must be connected in parallel with the inductance. Connection in parallel with the output contact is not permitted. Please also note that the selection of the suppressors can increase the total switch off times.

Suppression diodes should not be used as arc-suppressors, as they considerably increase the switch off time. RC elements are more suitable than varistors.

Fig. 16: Circuit for an inductive load

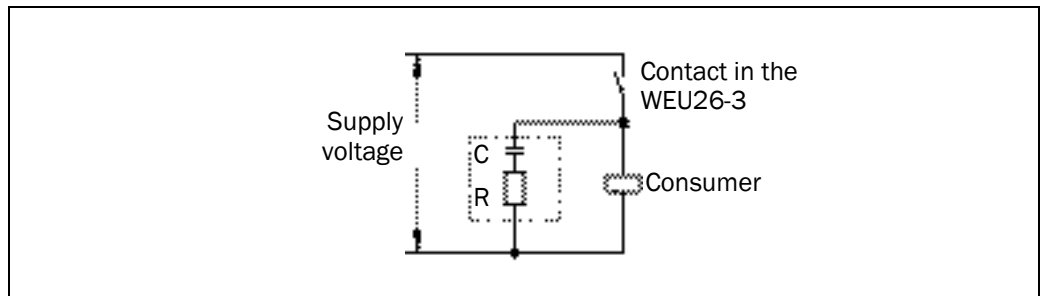

5.4 Cross-circuit monitoring

The cables for the relay contacts are not monitored for cross-circuits by the WEU26-3.



WARNING

Suitable measures

Take suitable measures for cross-circuit monitoring.

These can be:

- laying cables from the WEU26-3 to the loads protected against cross-circuits,
- screening output cables separately and connecting screen to 0 V,
- integration of the two normally open contacts at different voltage levels.

5.5 Overcurrent protection (fuse)

A fuse is to be installed in the control circuit with a rating to suit the maximum current on the output relay.

6 Commissioning



WARNING

Commissioning requires a thorough check by qualified safety personnel!

Before you operate a system protected by the WSU/WEU26-3 devices for the first time, make sure that the system is first checked and released by qualified safety personnel. Please read the notes in chapter 2 "On safety".

The device is switched on by applying the supply voltage to the sender and receiver unit. After max. 10 s the WSU/WEU26-3 devices are ready for operation.

6.1 Aligning sender and receiver

After all parts have been mounted and connected, the related sender and receiver must be aligned in relation to each other.



WARNING

Secure the plant/system. No dangerous movement possible!

Ensure that the dangerous state of the machine is (and remains) switched off! During the alignment process, the outputs of the WSU/WEU26-3 devices are not allowed to have any effect on the machine.

6.1.1 Alignment using the diagnostics LEDs

Switch on power supply. The yellow diagnostics LED of the WSU26-3 must light up. Align devices such that the green diagnostics LED on the WEU26-3 illuminates.

Fig. 17: WSU26-3 sender unit and WEU26-3 receiver unit

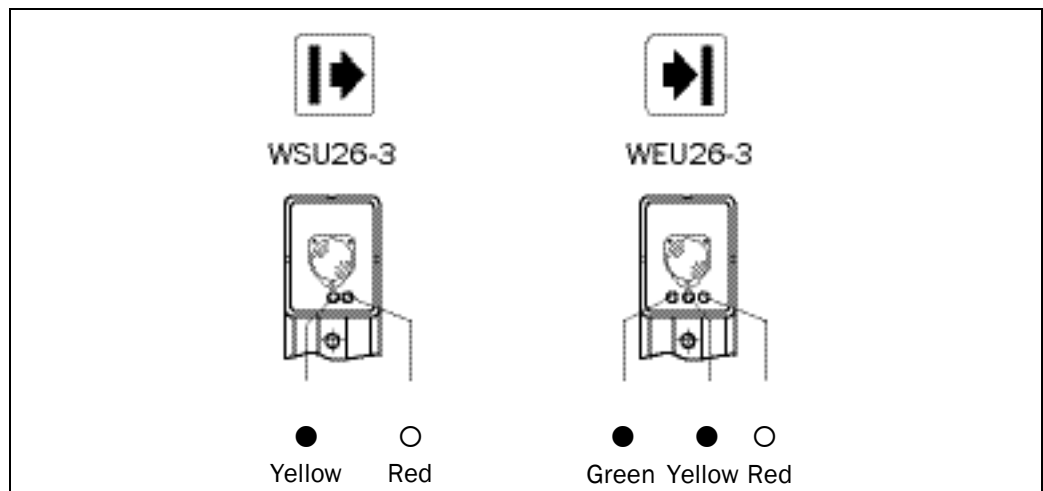

For optimal alignment the sender and receiver, the boundaries are to be determined by pivoting the sender unit and receiver unit horizontally and vertically. On leaving the related optical area, the yellow diagnostics LED on the WEU26-3 starts to illuminate. Then fasten sender and receiver in the middle of the optical area determined.

6.1.2 Alignment using the AR60 laser alignment aid

At large scanning ranges or in case of the usage of deflector mirrors, the laser alignment aid AR60 significantly simplifies alignment. The AR60 alignment aid is available as an accessory (Tab. 17, page 36).

- Screw the adapter to the AR60,
- mount the AR60 in front of the sender (clamp),
- switch on AR60,
- attach a piece of white cardboard or with cardboard reflective tape to the receiver (beam array is easier to detect),
- align sender such that the laser beam array is incident on the middle of the receiver optics,
- fasten sender in this position,
- switch off AR60,
- remove AR60,
- repeat the process starting from the receiver,
- switch on sensors.

Fig. 18: Mounting the laser alignment aid AR60

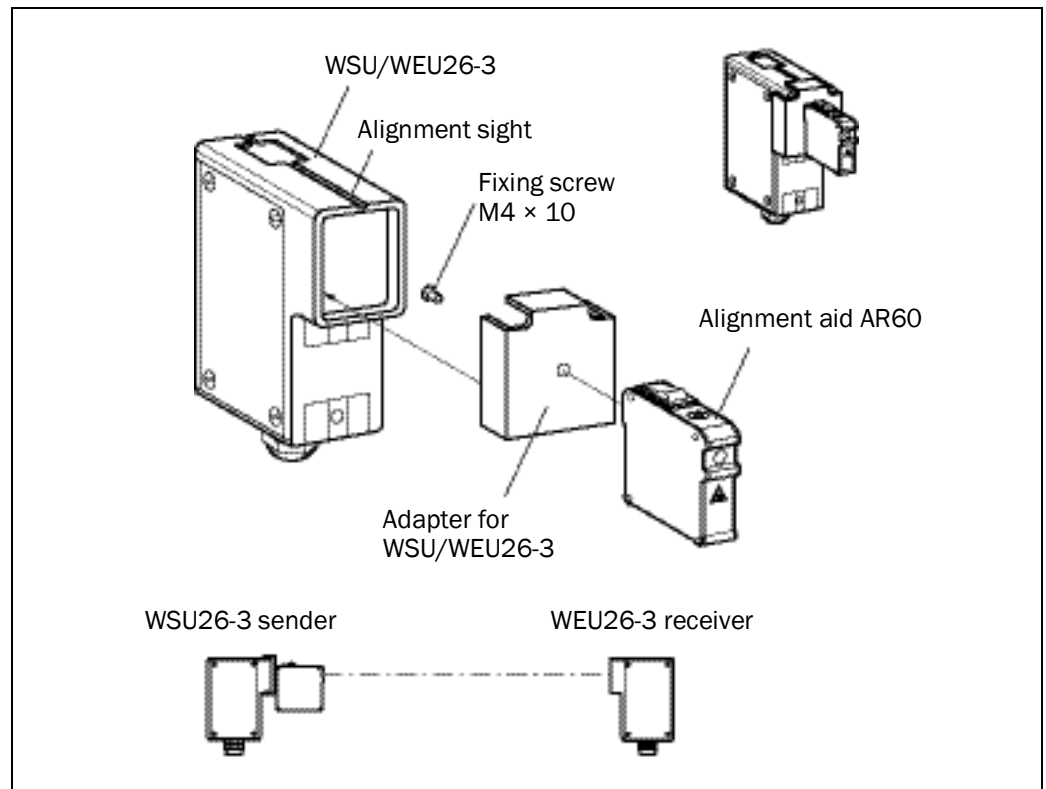

6.2 Test notes

6.2.1 Tests before the initial commissioning

Check the protective device as described below and in accordance with the applicable standards and regulations.

To ensure the correct function, check as described in chapter 6.2.2 “Daily functional checks of the protective device”.

- Number of sender and receiver must match, the distance between them must comply with the operating range stated in the technical specifications.
- It must only be possible to access the hazardous area through the light path between sender and receiver.
- It must not be possible to climb over, to crawl beneath or to circumnavigate the protective device.
- Additionally, check the effectiveness of the protective device mounted to the machine, using all selectable operating modes as specified in the checklist (see chapter 11.2 “Checklist for the manufacturer”). Use this checklist as a reference before commissioning the system for the first time.
- Ensure that the operating personnel of the machine protected by the WSU/WEU26-3 devices are correctly instructed by qualified safety personnel before being allowed to operate the machine. Instructing the operating personnel is the responsibility of the machine owner.

6.2.2 Daily functional checks of the protective device

The effectiveness of the protective device must be checked daily or prior to the start of work by a specialist or by authorised personnel, using the correct test rod.

Testing the light path between sender and receiver:

- Completely cover each light beam with a test rod that is not transparent to light (at least 30 mm diameter) at the following positions:
 - immediately in front of the sender,
 - in the middle between sender and receiver (or between the deflector mirrors),
 - immediately in front of the receiver,
 - on the use of deflector mirrors, immediately before and after the deflection.

This must produce the following result:

- The red diagnostics LED must illuminate on the receiver for the related single-beam photoelectric safety switch
- and
- as long as the light beam is interrupted, it must not be possible to initiate the dangerous state.



WARNING

Do not operate the machine if during the test the green diagnostics LED on the receiver is lit!

If the green diagnostics LED on the receiver lights up during the test even for a short period, work must stop at the machine. In this case the installation of the WSU/WEU26-3 devices must be checked by qualified safety personnel.

Further tests

- Check the protective device for damage or wear, particularly the mounting, the electrical connection and the connection cable, the housing and the front screen.
- Check whether the access to the hazardous area is only possible by interrupting the light path between sender and receiver (e.g. correct mounting of mechanical protective devices).
- Check whether the protective device is effective for the set operating mode.

6.2.3 Regular inspection of the protective device by qualified safety personnel

- Check the system, following the inspection intervals specified in the national rules and regulations. This procedure ensures that any changes on the machine or manipulations of the protective device after the initial commissioning are detected.
- If major changes have been made to the machine or the protective device, or if the single-beam photoelectric safety switch has been modified or repaired, check the plant again as per the checklist in the annex.

7 Care and maintenance

The WSU/WEU26-3 devices are maintenance-free. The integrated relay contacts are subject to normal wear. The front screen of the sensors should be regularly cleaned and also if contaminated.

Note Avoid scratches and misting of the front screens as well as the formation droplets, frost and ice on the front screens, as the optical properties may change.

➤ Do not use aggressive cleaning agents.

➤ Do not use abrasive cleaning agents.

Note Static charges cause dust particles to be attracted to the front screen. You can reduce this effect by using the antistatic plastic cleaner (SICK part number 5600006) and the SICK lens cloth (part number 4003353).

How to clean the front screen:

➤ Use a clean and soft brush to remove dust from the front screen.

➤ Now wipe the front screen with a clean and damp cloth.

Note After cleaning, check the position of sender and receiver to ensure that the protective device cannot be bypassed (climbing over, crawling beneath or standing behind).

➤ Verify the effectiveness of the protective device as described in chapter 6.2 "Test notes".

8 Fault diagnosis

This chapter describes how to identify and rectify errors and malfunctions during the operation of the WSU/WEU26-3 devices.

8.1 In the event of faults or errors



WARNING

Cease operation if the cause of the malfunction has not been clearly identified!

Stop the machine if you cannot clearly identify or allocate the error or if you cannot safely rectify the malfunction.



WARNING

Complete function test after rectification of fault!

After rectifying a fault, perform a complete function test as per chapter 6.2 "Test notes".

8.2 SICK support

If you cannot remedy an error with the help of the information provided in this chapter, please contact your local SICK representative.

8.3 Status displays of the diagnostics LEDs

This section describes the meaning of the diagnostics LED and how to respond.

Diagnostics LEDs of the sender

Tab. 11: Diagnostics LEDs WSU26-3

Display		Possible cause	Rectification of the error
Yellow	Red		
○	○	No operating voltage, or voltage too low	➤ Check the supply voltage and activate, if necessary.
●	 (1 Hz, switch-on time 10 %)	System error	➤ Switch the device off for at least 3 seconds and then back on again. If the error continues to occur: ➤ Replace the device.

Diagnostics LEDs of the receiver

Tab. 12: Diagnostics LEDs WEU26-3

Display			Possible cause	Rectification of the error
Green	Yellow	Red		
○	○	○	No operating voltage, or voltage too low	➤ Check the supply voltage and activate, if necessary.
○	☀ (1 Hz, switch-on time 10 %)	●	System error	➤ Switch the device off for at least 3 seconds and then back on again. If the error continues to occur: ➤ Replace the device.
○	☀ (1 Hz, switch-on time 90 %)	●	Error in the supply voltage or unknown sender detected	➤ Switch the device off for at least 3 seconds and then back on again. ➤ Check whether the power supply complies with the specification (see chapter 5.1 on page 22). ➤ Check whether the power supply complies with the technical specifications (see chapter 9 on page 33). ➤ Check the distance from reflective surfaces (see chapter 4.1.2 on page 16) and from other single-beam photoelectric safety switches. ➤ Mount non-reflective field of view guards, if necessary. If the error continues to occur: ➤ Replace the device.

9 Technical specifications

Tab. 13: Technical specifications

	Minimum	Typical	Maximum
General system data			
Operating range WEU26-3-103A00 WEU26-3-203A00	0.5 m 15 m		20 m 70 m
Number of beams	1		
Synchronisation	optical, without separate synchronisation cable		
Detection capability		30 mm	
Protection class (EN 50178:1998) ¹⁾	I		
Enclosure rating (IEC 60529)	IP 67		
Operating mode	Protective operation without start and restart interlock		
Supply voltage V_S ²⁾	19.2 V DC	24 V DC	28.8 V DC
Residual ripple ³⁾			±10 %
Power-up delay of receiver and sender before ready		5 s	10 s
Type	Type 4 (IEC 61496)		
Safety integrity level ⁴⁾	SIL3 (IEC 61508), SILCL3 (EN 62061)		
Category	Category 4 (EN ISO 13849)		
Performance Level ⁴⁾	PL e (EN ISO 13849)		
B _{10d} value	AC-15, 230 V, 0.4 A: 1 x 10 ⁶ switching operations AC-15, 230 V, 2.0 A: 2.6 x 10 ⁵ switching operations DC-13, 24 V, 0.6 A: 1 x 10 ⁶ switching operations DC-13, 24 V, 1.5 A: 2 x 10 ⁵ switching operations		
PFHd (mean probability of a dangerous failure per hour)	4.0 x 10 ⁻⁹		
T _M (mission time)	20 years (EN ISO 13849)		

¹⁾ Safety extra-low voltage SELV/PELV is mandatory.

²⁾ The external voltage supply must be capable of buffering brief mains voltage failures of 20 ms as specified in EN 60204. Suitable power supplies are available as accessories from SICK.

³⁾ The maximum supply voltage limits must not be exceeded, minimum levels must be achieved.

⁴⁾ For detailed information on the exact design of your machine/system, please contact your local SICK representative.

	Minimum	Typical	Maximum
Sender unit			
Wavelength		950 nm	
Test input Type of circuit:	Volt-free normally closed contact or wire jumpers between the test contacts ¹⁾		
- Duration of the actuation of the normally closed contact - Response time to test input signal	50 ms	150 ms	200 ms
Power consumption			6 W
Weight			1 kg
Receiver unit			
Outputs	Volt-free relay contacts, 2 normally open contacts, 1 normally closed contact (2 normally closed contacts connected in parallel internally)		
Contact material	Ag alloy with Au coating		
Switching frequency			0.2 Hz
Switching voltage	10 V DC 10 V AC		30 V DC 230 V AC
Switching current	20 mA		2 A
Mechanical life relay contacts	≥ 10 ⁷ switching operations		
Electrical service life of relay contacts with reference loads	≥ 10 ⁵ switching operations		
Reference loads by usage category	AC-15 with 230 V, 2 A, AC-1 with 230 V, 2 A, DC-1 with 24 V, 2 A, DC-13 with 24 V, 1.5 A		
Response time			22 ms
Switch-off time	80 ms		
Power consumption			8 W
Weight			1 kg

¹⁾ Connect the contacts on the WSU26-3 only to circuits that comply with the requirements for safety extra-low voltage (SELV/PELV).

	Minimum	Typical	Maximum
Operational data			
Connection	Cable gland (PG 13.5)		
Core cross-section	0.2 mm ²		1.5 mm ²
Cable length for cross-section ¹⁾			
- 0.25 mm ²			14 m
- 0.75 mm ²			42 m
- 1.5 mm ²			83 m
Ambient operating temperature	-25 °C		+55 °C
Storage temperature	-25 °C		+70 °C
Air humidity (non-dewing)	15 %		95 %
Dimensions	see Dimensional drawings		
Vibration resistance	5 g, 10 ... 55 Hz according to EN 60068-2-6		
Shock resistance	10 g, 16 ms according to EN 60068-2-29		
Environmental data			
Housing	Aluminium alloy ALSI12(CU)		
Front screen	Polycarbonate (scratch-resistant coating)		
Circuit boards	Glassfibre reinforced epoxy resin		
Packaging	Corrugated cardboard		

¹⁾ When using copper cables ($\rho = 0.018 \Omega \text{ mm}^2/\text{m}$).

10 Ordering information

10.1 Devices

Tab. 14: Ordering information devices

Part	Type	Part number
Single-beam photoelectric safety switch: Sender unit with PG gland (13,5)	WSU26/3-103A00	1047984
Single-beam photoelectric safety switch: Receiver unit with PG gland (13,5), scanning range 0.5 m ... 20 m	WEU26/3-103A00	1047985
Single-beam photoelectric safety switch: Receiver unit with PG gland (13,5), scanning range 15 m ... 70 m	WEU26/3-203A00	1048379
Single-beam photoelectric safety switch: Sender unit with male connector M12, 8-pin	WSU26/3- 103A00S01	1089126
Single-beam photoelectric safety switch: Receiver unit with male connector M12, 8-pin, scanning range 15 m ... 70 m	WEU26/3- 203A00S01	1089127

10.2 Deflector mirror

Tab. 15: Ordering information deflector mirrors

Part	Type	Part number
Deflector mirror	PSK1	1005229
Bracket for deflector mirror	BEF-1UNIBFST1	2118668
Spring fastening for deflector mirror PSK1	BEF-4AAAAHST3	2012473
Deflector mirror	PSK 45	5306053
Deflector mirror	PNS75-008	1026647

10.3 Accessories

Tab. 16: Ordering information accessories

Part	Type	Part number
Mounting bracket WSU/WEU	BEF-4WNAEFAL1	2007900
Alignment aid	AR60	1015741
Adapter for alignment aid AR60		4031156
PG expansion, PG 13.5 auf PG 21		5306052
PG cable entry PG 21 in the case of the usage of two cables		5305978
Power supply, voltage supply 24 V DC, 2.1 A		7028789
Power supply, voltage supply 24 V DC, 3.9 A		7028790
Dust protection tube		1003556
Weather protection		1003619
Test rod bracket	BEF-3WNAAAAL1	2052249
Test rod, 30 mm		2022602

WSU/WEU26-3

10.4 Dimensional drawings

Fig. 19: WSU/WEU26-3

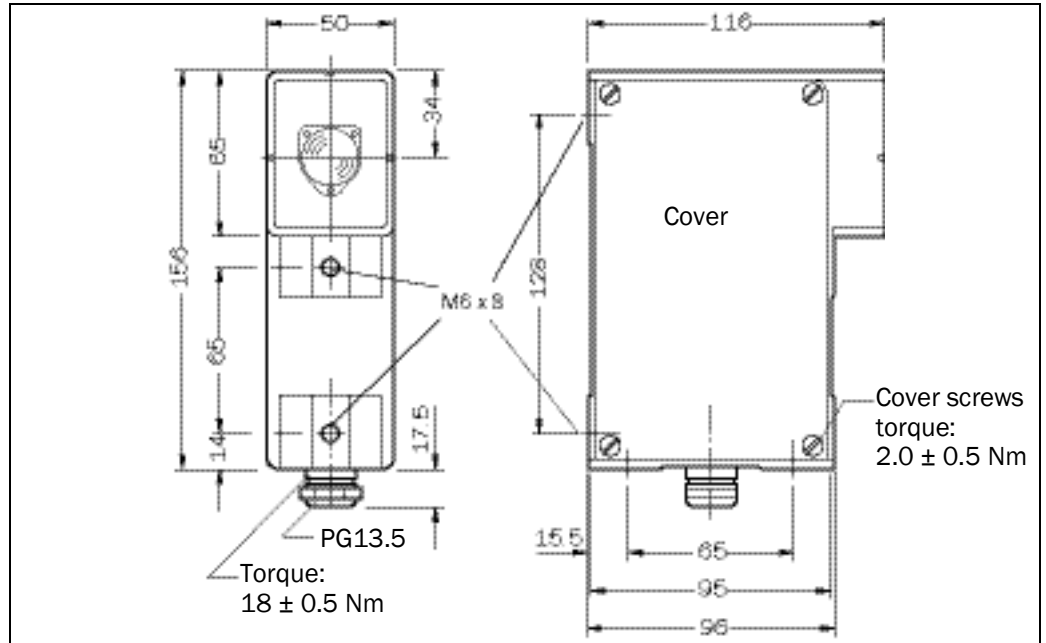

Fig. 20: Deflector mirror PSK1

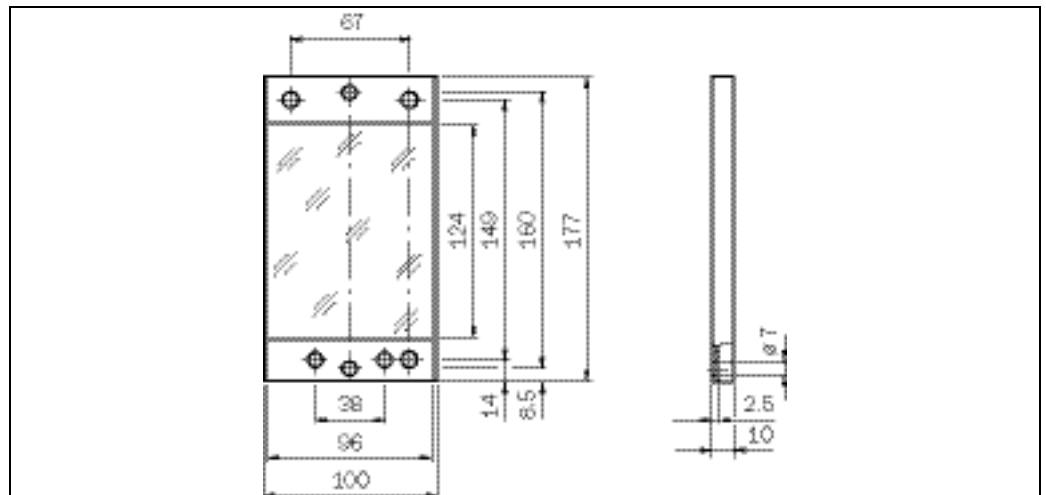

Fig. 21: Spring fastening for deflector mirror PSK1

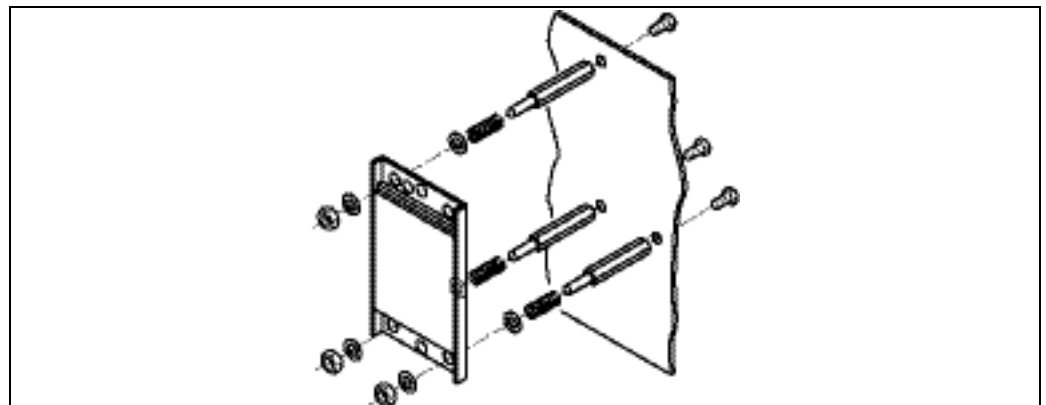

Fig. 22: Deflector mirror PSK45 (M = Middle of the mirror surface)

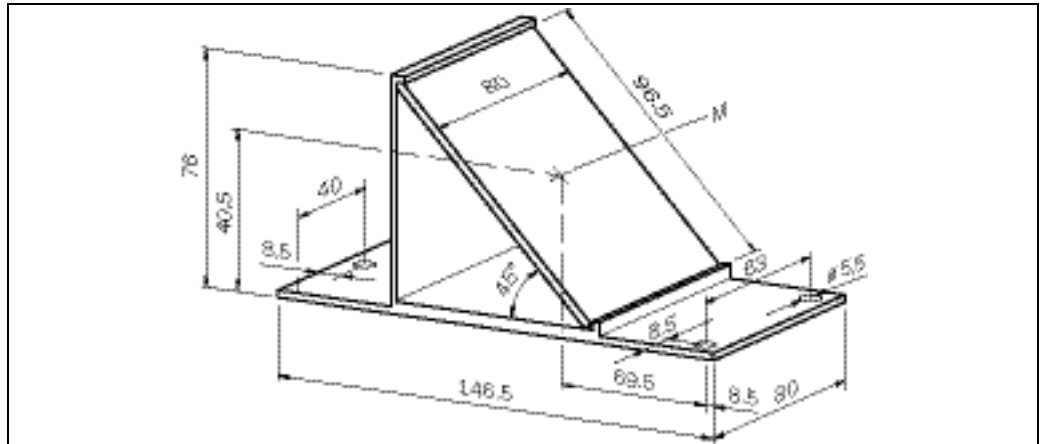

Fig. 23: Mounting bracket
WSU/WEU

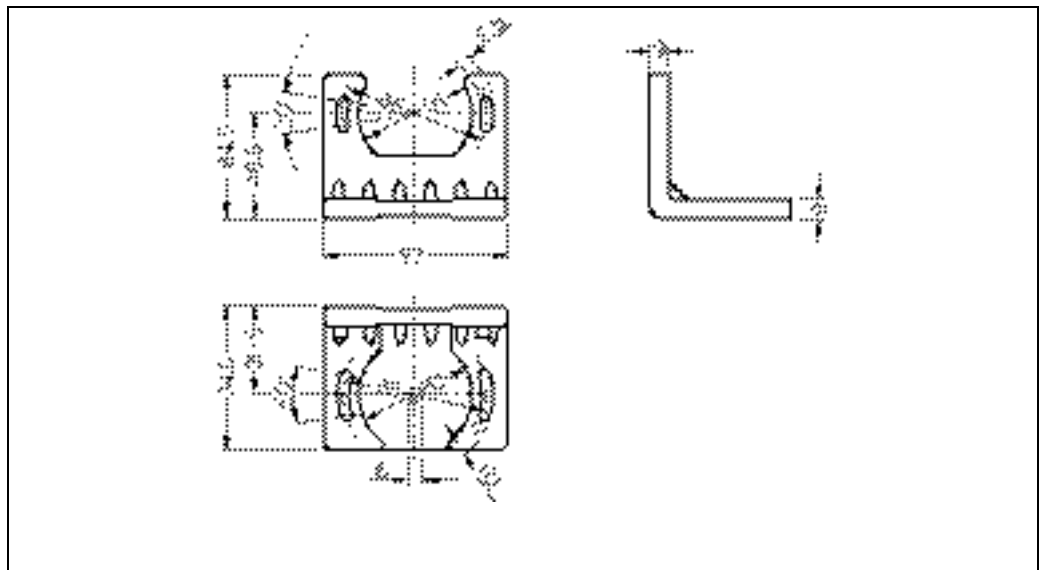
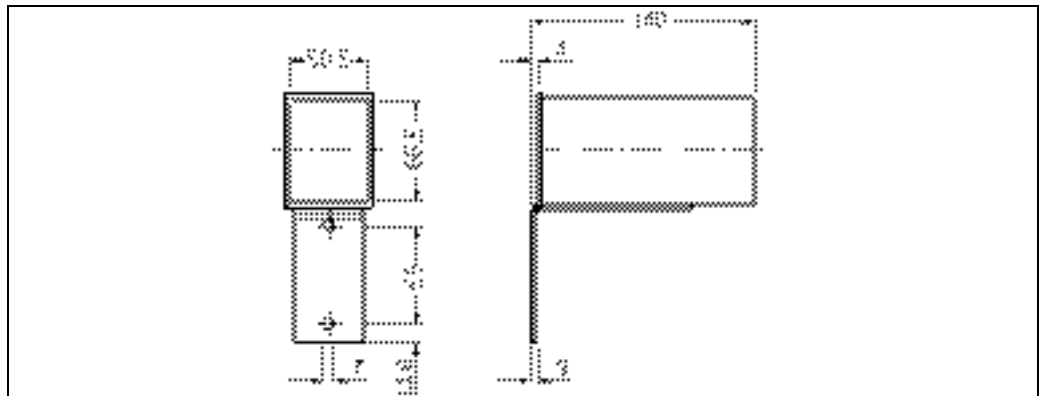
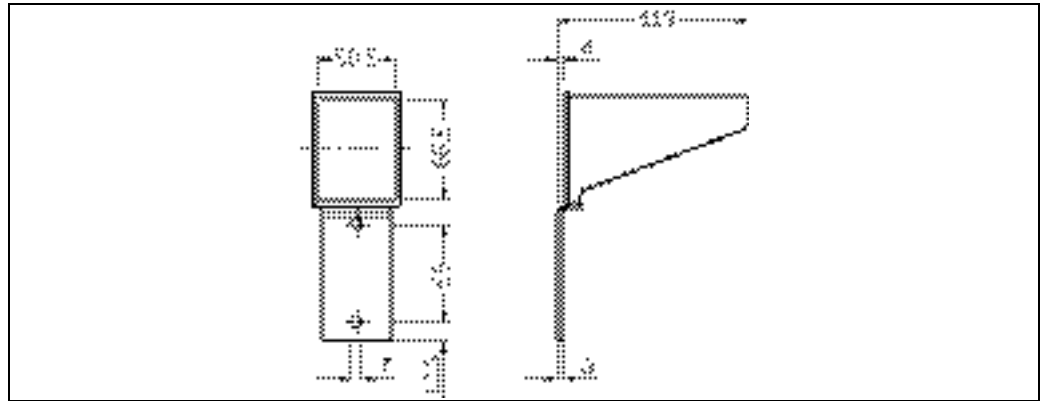

Fig. 24: Dust protection tube



WSU/WEU26-3

Fig. 25: Weather protection



11 Annex

11.1 Compliance with EU directives

EU declaration of conformity (excerpt)

The undersigned, representing the following manufacturer herewith declares that the product is in conformity with the provisions of the following EU directive(s) (including all applicable amendments), and that the respective standards and/or technical specifications are taken as the basis.

Complete EU declaration of conformity for download: www.sick.com

11.2 Checklist for the manufacturer

SICK

Checklist for the manufacturer/installer for the installation of electro-sensitive protective equipment (ESPE)

Details about the points listed below must be present at least during initial commissioning – they are, however, dependent on the respective application, the specifications of which are to be controlled by the manufacturer/installer. This checklist should be retained and kept with the machine documentation to serve as reference during recurring tests.

1. Have the safety rules and regulations been observed in compliance with the directives/standards applicable to the machine? Yes No
2. Are the applied directives and standards listed in the declaration of conformity? Yes No
3. Does the protective device comply with the required PL/SIL claim limit and PFHd in accordance with EN ISO 13849-1/EN 62061 and the required type in accordance with IEC 61496-1? Yes No
4. Is the access to the hazardous area/hazardous point only possible through the protective field of the ESPE? Yes No
5. Have appropriate measures been taken to protect (mechanical protection) or monitor (protective devices) any persons or objects in the hazardous area when protecting a hazardous area or hazardous point, and have these devices been secured or locked to prevent their removal? Yes No
6. Are additional mechanical protective measures fitted and secured against manipulation which prevent reaching under, over or around the ESPE? Yes No
7. Has the maximum stopping and/or stopping/run-down time of the machine been measured, specified and documented (at the machine and/or in the machine documentation)? Yes No
8. Has the ESPE been mounted such that the required minimum distance from the nearest hazardous point has been achieved? Yes No
9. Are the ESPE devices correctly mounted and secured against manipulation after adjustment? Yes No
10. Are the required protective measures against electric shock in effect (protection class)? Yes No
11. Is the control switch for resetting the protective device (ESPE) or restarting the machine present and correctly installed? Yes No
12. Are the outputs of the ESPE (OSSD) integrated according to required PL/SILCL compliant with EN ISO 13849-1/EN 62061 and does the integration correspond to the comply with the circuit diagrams? Yes No
13. Has the protective function been checked in compliance with the test notes of this documentation? Yes No
14. Are the specified protective functions effective at every operating mode that can be set? Yes No
15. Are the switching elements activated by the ESPE, e.g. contactors, valves, monitored? Yes No
16. Is the ESPE effective over the entire period of the dangerous state? Yes No
17. Once initiated, will a dangerous state be stopped when switching the ESPE on or off and when changing the operating mode, or when switching to another protective device? Yes No
18. Has the information label for the daily check been attached so that it is easily visible for the operator? Yes No

This checklist does not replace the initial commissioning, nor the regular inspection by qualified safety personnel.

11.3 List of tables

Tab. 1:	Overview on disposal by components	9
Tab. 2:	Receiver variants.....	11
Tab. 3:	Diagnostics LEDs WSU26-3	12
Tab. 4:	Diagnostics LEDs WEU26-3.....	12
Tab. 5:	Height of the beams above the floor	15
Tab. 6:	Formula for the calculation of the minimum distance to reflective surfaces	17
Tab. 7:	Reduction in the scanning range on the usage of deflector mirrors with $\alpha = 90^\circ$	20
Tab. 8:	Distances of the deflector mirrors.....	21
Tab. 9:	Assignment of the sensor contacts, sender WSU26-3.....	22
Tab. 10:	Assignment of the sensor contacts, receiver WEU26-3	23
Tab. 11:	Diagnostics LEDs WSU26-3	31
Tab. 12:	Diagnostics LEDs WEU26-3.....	31
Tab. 13:	Technical specifications	33
Tab. 14:	Ordering information devices	36
Tab. 15:	Ordering information deflector mirrors.....	36
Tab. 16:	Ordering information accessories	36

11.4 List of illustrations

Fig. 1:	Key data for the WSU/WEU26-3 devices	10
Fig. 2:	Diagnostics LEDs WSU26-3	11
Fig. 3:	Diagnostics LEDs WEU26-3.....	12
Fig. 4:	Access guarding with WSU/WEU26-3	13
Fig. 5:	Safety distance S to the light beam	14
Fig. 6:	Minimum distance to reflective surfaces	16
Fig. 7:	Graph, minimum distance from reflective surfaces	17
Fig. 8:	Mounting two WSU/WEU26-3 devices in series.....	17
Fig. 9:	Mounting possibilities using mounting brackets.....	18
Fig. 10:	Hazardous area protected on several sides.....	20
Fig. 11:	Two-beam protection with one system WSU/WEU26-3.....	20
Fig. 12:	Incorrect alignment of sender and receiver	21
Fig. 13:	Correct alignment of sender and receiver	21
Fig. 14:	Assignment of the sensor contacts, sender WSU26-3.....	23
Fig. 15:	Assignment of the sensor contacts, connection diagram WEU26-3 on UE43	24
Fig. 16:	Circuit for an inductive load	25
Fig. 17:	WSU26-3 sender unit and WEU26-3 receiver unit.....	26
Fig. 18:	Mounting the laser alignment aid AR60.....	27
Fig. 19:	WSU/WEU26-3.....	37
Fig. 20:	Deflector mirror PSK1	37
Fig. 21:	Spring fastening for deflector mirror PSK1	37

WSU/WEU26-3

Fig. 22: Deflector mirror PSK45 (M = Middle of the mirror surface).....	37
Fig. 23: Mounting bracket WSU/WEU.....	38
Fig. 24: Dust protection tube.....	38
Fig. 25: Weather protection.....	39

Australia

Phone +61 (3) 9457 0600
1800 33 48 02 – tollfree
E-Mail sales@sick.com.au

Austria

Phone +43 (0) 2236 62288-0
E-Mail office@sick.at

Belgium/Luxembourg

Phone +32 (0) 2 466 55 66
E-Mail info@sick.be

Brazil

Phone +55 11 3215-4900
E-Mail comercial@sick.com.br

Canada

Phone +1 905.771.1444
E-Mail cs.canada@sick.com

Czech Republic

Phone +420 234 719 500
E-Mail sick@sick.cz

Chile

Phone +56 (2) 2274 7430
E-Mail chile@sick.com

China

Phone +86 20 2882 3600
E-Mail info.china@sick.net.cn

Denmark

Phone +45 45 82 64 00
E-Mail sick@sick.dk

Finland

Phone +358-9-25 15 800
E-Mail sick@sick.fi

France

Phone +33 1 64 62 35 00
E-Mail info@sick.fr

Germany

Phone +49 (0) 2 11 53 010
E-Mail info@sick.de

Greece

Phone +30 210 6825100
E-Mail office@sick.com.gr

Hong Kong

Phone +852 2153 6300
E-Mail ghk@sick.com.hk

Hungary

Phone +36 1 371 2680
E-Mail ertesites@sick.hu

India

Phone +91-22-6119 8900
E-Mail info@sick-india.com

Israel

Phone +972 97110 11
E-Mail info@sick-sensors.com

Italy

Phone +39 02 27 43 41
E-Mail info@sick.it

Japan

Phone +81 3 5309 2112
E-Mail support@sick.jp

Malaysia

Phone +603-8080 7425
E-Mail enquiry.my@sick.com

Mexico

Phone +52 (472) 748 9451
E-Mail mexico@sick.com

Netherlands

Phone +31 (0) 30 229 25 44
E-Mail info@sick.nl

New Zealand

Phone +64 9 415 0459
0800 222 278 – tollfree
E-Mail sales@sick.co.nz

Norway

Phone +47 67 81 50 00
E-Mail sick@sick.no

Poland

Phone +48 22 539 41 00
E-Mail info@sick.pl

Romania

Phone +40 356-17 11 20
E-Mail office@sick.ro

Russia

Phone +7 495 283 09 90
E-Mail info@sick.ru

Singapore

Phone +65 6744 3732
E-Mail sales.gsg@sick.com

Slovakia

Phone +421 482 901 201
E-Mail mail@sick-sk.sk

Slovenia

Phone +386 591 78849
E-Mail office@sick.si

South Africa

Phone +27 10 060 0550
E-Mail info@sickautomation.co.za

South Korea

Phone +82 2 786 6321/4
E-Mail infokorea@sick.com

Spain

Phone +34 93 480 31 00
E-Mail info@sick.es

Sweden

Phone +46 10 110 10 00
E-Mail info@sick.se

Switzerland

Phone +41 41 619 29 39
E-Mail contact@sick.ch

Taiwan

Phone +886-2-2375-6288
E-Mail sales@sick.com.tw

Thailand

Phone +66 2 645 0009
E-Mail marcom.th@sick.com

Turkey

Phone +90 (216) 528 50 00
E-Mail info@sick.com.tr

United Arab Emirates

Phone +971 (0) 4 88 65 878
E-Mail contact@sick.ae

United Kingdom

Phone +44 (0)17278 31121
E-Mail info@sick.co.uk

USA

Phone +1 800.325.7425
E-Mail info@sick.com

Vietnam

Phone +65 6744 3732
E-Mail sales.gsg@sick.com

Detailed addresses and further locations at www.sick.com