

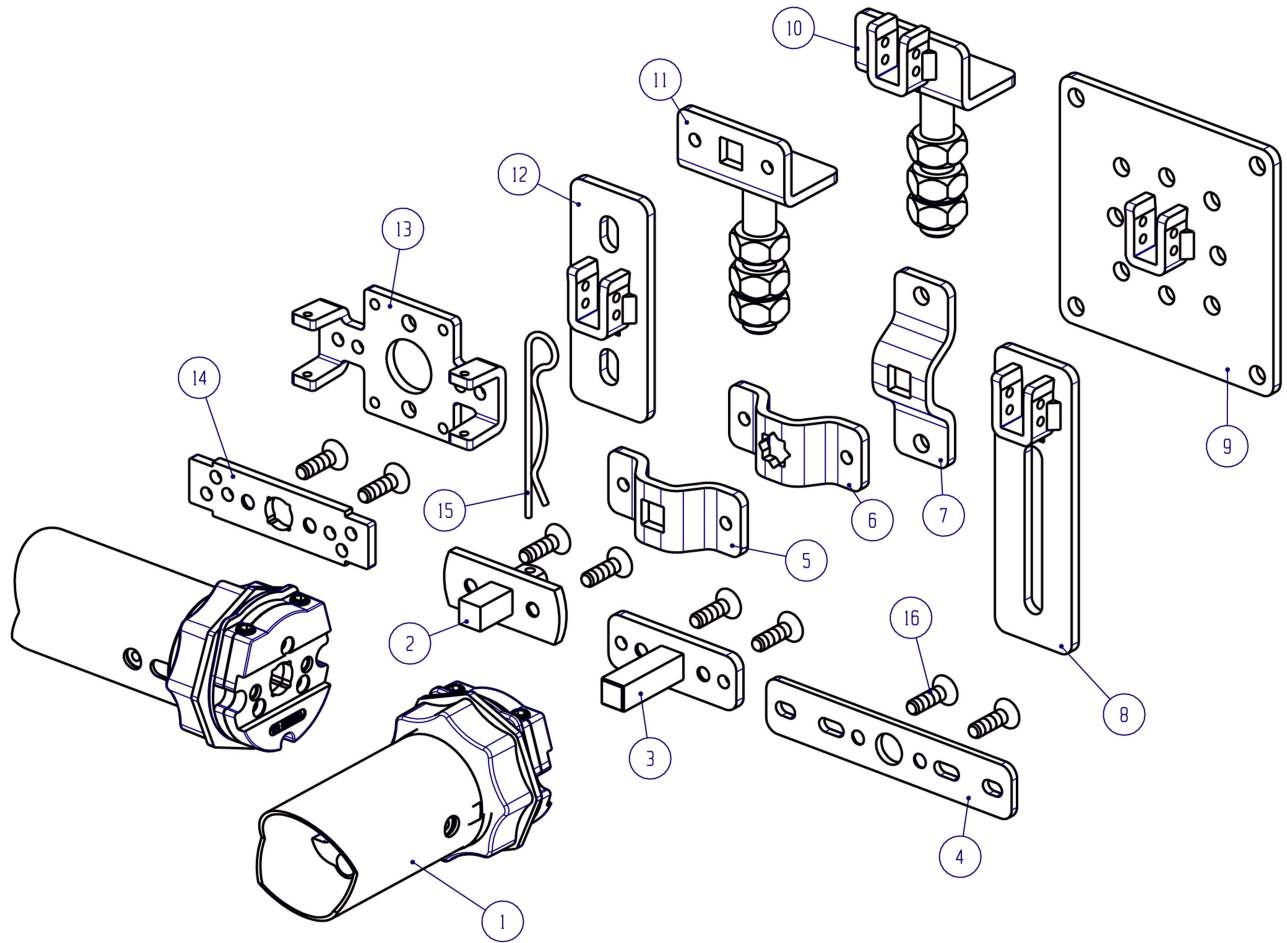

# GEARMOTOR ASSEMBLY SYSTEMS - **CRONO** SERIES



N.	Description	Code	N.	Description	Code
<b>1</b>	Motor - CRONO series		<b>21</b>		
<b>2</b>	Support pin - 10x10mm square, CRONO	<b>AC125</b>	<b>22</b>		
<b>3</b>	Assembly bracket - H60mm, square pin	<b>AC013A</b>	<b>23</b>		
<b>4</b>	Assembly bracket - H115mm, 12mm dia. hole, 10mm dia. hole	<b>AC015</b>	<b>24</b>		
<b>5</b>	Support bracket - H62mm, 10x10mm square hole	<b>AC017</b>	<b>25</b>		
<b>6</b>	Support bracket - H62mm, 45°/90° hole	<b>AC127</b>	<b>26</b>		
<b>7</b>	Support bracket - H74mm, 10x10mm square hole	<b>AC018</b>	<b>27</b>		
<b>8</b>	Support bracket - H116mm, 10mm dia. high mounting support	<b>AC122</b>	<b>28</b>		
<b>9</b>	Support bracket - H100mm square, 10mm dia. high mounting support	<b>AC120</b>	<b>29</b>		
<b>10</b>	Support bracket - M12 mounting support	<b>AC034</b>	<b>30</b>		
<b>11</b>	Pin support bracket - M12	<b>AC032</b>	<b>31</b>		
<b>12</b>	Support bracket - H90mm, 10mm dia. central mounting support	<b>AC124</b>	<b>32</b>		
<b>13</b>	Assembly bracket - 21 mm dia. rod hole	<b>AC117</b>	<b>33</b>		
<b>14</b>	Support bracket - H84mm, BIG CRONO	<b>AC118</b>	<b>34</b>		
<b>15</b>	Safety clip - 2mm dia.	<b>VT152</b>	<b>35</b>		
<b>16</b>	Screw - Phillips head, countersunk, flat, 5x30mm, HILO, zinc	<b>VT035</b>	<b>36</b>		
<b>17</b>			<b>37</b>		
<b>18</b>			<b>38</b>		
<b>19</b>			<b>39</b>		
<b>20</b>			<b>40</b>		