



Switch Amplifier

HiC2853

- 1-channel isolated barrier
- 24 V DC supply (bus powered)
- Input for approved dry contacts or SN/S1N sensors
- Usable as signal splitter (1 input and 2 outputs)
- Active voltage output
- Passive transistor output (resistive acc. to EN 60947-5-6)
- Line fault detection (LFD)
- Line fault transparency (LFT)
- Up to SIL 3 acc. to IEC/EN 61508



SIL 3



Function

This isolated barrier is used for intrinsic safety applications. The device transfers digital signals (SN/S1N proximity sensors or approved dry contacts) from the explosion-hazardous area to the non-explosion-hazardous area. The input controls one active voltage output and one passive transistor output with a resistive output characteristic acc. to EN 60947-5-6. The passive transistor output has three defined states: 1-signal = 1.8 kΩ, 0-signal = 14 kΩ and fault > 100 kΩ. This output characteristic offers line fault transparency on the signal lines. During a fault state, both outputs switch to their fault state and LEDs indicate the fault according to NAMUR NE 44. A separate fault bus is available. This fault bus can be monitored if the termination board supports a module fault detection. Unlike a SN/S1N series safety sensor, an approved dry contact requires a 10 kΩ resistor to be placed across the contact in addition to a 1.5 kΩ resistor in series. This device mounts on a HiC termination board.

Connection

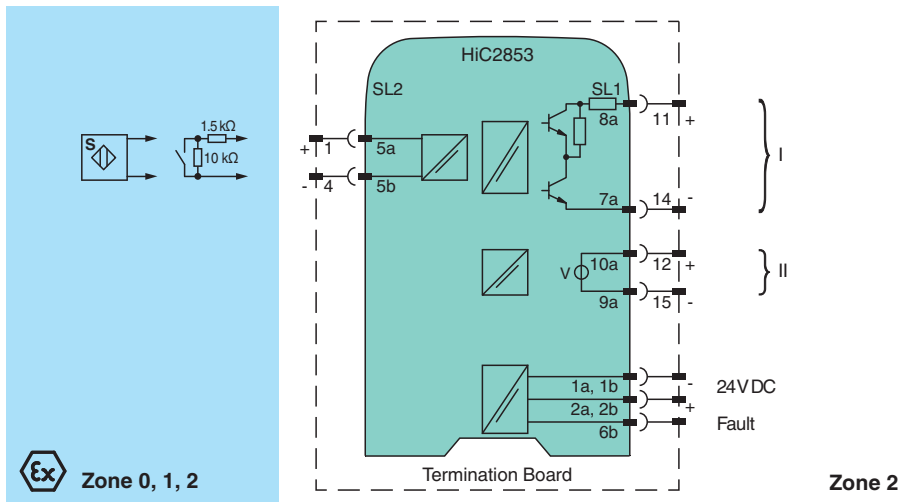

Technical Data

General specifications		
Signal type		Digital Input
Functional safety related parameters		
Safety Integrity Level (SIL)		SIL 3
Systematic capability (SC)		SC 3
Supply		
Connection		SL1: 1a(-), 1b(-); 2a(+), 2b(+)
Rated voltage	U_r	19 ... 30 V DC bus powered via Termination Board

Release date: 2022-09-15 Date of issue: 2022-09-15 Filename: 233599_eng.pdf

Refer to "General Notes Relating to Pepperl+Fuchs Product Information".

Pepperl+Fuchs Group
www.pepperl-fuchs.com

USA: +1 330 486 0002
pa-info@us.pepperl-fuchs.com

Germany: +49 621 776 2222
pa-info@de.pepperl-fuchs.com

Singapore: +65 6779 9091
pa-info@sg.pepperl-fuchs.com



Technical Data

Ripple		≤ 10 %
Rated current	I_r	≤ 55 mA
Power dissipation		≤ 800 mW
Power consumption		≤ 1300 mW
Input		
Connection side		field side
Connection		SL2: 5a(+), 5b(-)
Open circuit voltage/short-circuit current		approx. 8.4 V DC / approx. 11.9 mA
Switching point/switching hysteresis		2.1 ... 2.8 mA / approx. 0.3 mA
Line fault detection		breakage $I \leq 0.15$ mA , short-circuit $I \geq 8.5$ mA
Lead resistance		max. 50 Ω , consider capacitances and inductances
Switching point		1-signal: $I > 2.8$ mA 0-signal: $I < 2.1$ mA
Response delay		≤ 1 ms
Output		
Connection side		control side
Connection		SL1: 8a(+), 7a(-); 10a(+), 9a(-)
Rated voltage	U_r	output I: typ. 8 V DC, max. 22 V DC
Output I		passive transistor output (resistive) 0-signal: 14 k Ω \pm 10 % 1-signal: 1.8 k Ω \pm 10 % fault: > 100 k Ω
Output II		active voltage output, short-circuit proof 0-signal: 0 V 1-signal: 20 ... 31 V DC at max. 15 mA fault: 0 V
Fault indication output		
Connection		SL1: 6b
Output type		open collector transistor (internal fault bus)
Transfer characteristics		
Switching frequency		
Output I		≤ 50 Hz
Output II		≤ 50 Hz
Galvanic isolation		
Output/power supply		functional insulation acc. to IEC 62103, rated insulation voltage 50 V _{eff}
Output/Output		functional insulation acc. to IEC 62103, rated insulation voltage 50 V _{eff}
Indicators/settings		
Display elements		LEDs
Labeling		space for labeling at the front
Directive conformity		
Electromagnetic compatibility		
Directive 2014/30/EU		EN 61326-1:2013 (industrial locations)
Conformity		
Electromagnetic compatibility		EN IEC 61326-3-2:2018 , NE 21:2017 For further information see system description.
Degree of protection		IEC 60529:2001
Ambient conditions		
Ambient temperature		-20 ... 60 °C (-4 ... 140 °F)
Mechanical specifications		
Degree of protection		IP20
Mass		approx. 105 g
Dimensions		12.5 x 106 x 128 mm (0.5 x 4.2 x 5.1 inch) (W x H x D)
Mounting		on termination board
Coding		pin 1 and 2 trimmed For further information see system description.
Data for application in connection with hazardous areas		

Release date: 2022-09-15 Date of issue: 2022-09-15 Filename: 233599_eng.pdf

Technical Data

EU-type examination certificate		BASEEFA 07 ATEX 0302X	
Marking		Ⓢ II (1)G [Ex ia] IIC , Ⓢ II (1) D [Ex ia] IIIC , Ⓢ I (M1) [Ex ia] I	
Input		Ex ia	
Voltage	U_o	10.5 V	
Current	I_o	17.1 mA	
Power	P_o	45 mW (linear characteristic)	
Supply			
Maximum safe voltage	U_m	253 V AC (Attention! U_m is no rated voltage.)	
Output			
Maximum safe voltage	U_m	253 V AC (Attention! U_m is no rated voltage.)	
Certificate		PF 09 CERT 1440 X	
Marking		Ⓢ II 3G Ex nA IIC T4 Gc	
Galvanic isolation			
Input/Output		safe electrical isolation acc. to IEC/EN 60079-11, voltage peak value 375 V	
Input/power supply		safe electrical isolation acc. to IEC/EN 60079-11, voltage peak value 375 V	
Directive conformity			
Directive 2014/34/EU		EN IEC 60079-0:2018+AC:2020 , EN 60079-11:2012 , EN 60079-15:2010	
International approvals			
UL approval		E106378	
Control drawing		116-0364	
IECEX approval			
IECEX certificate		IECEX BAS 07.0097X	
IECEX marking		[Ex ia Ga] IIC, [Ex ia] IIIC , [Ex ia] I	
General information			
Supplementary information		Observe the certificates, declarations of conformity, instruction manuals, and manuals where applicable. For information see www.pepperl-fuchs.com .	

Assembly

Front view

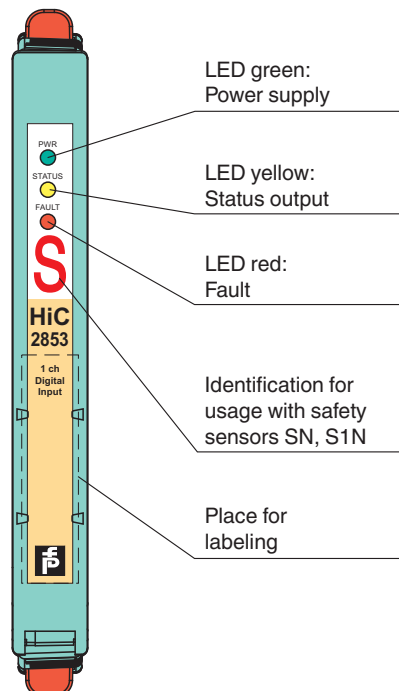

Configuration

No user configuration available for this device.

Safety Information



The pins for this device are trimmed to polarize it according to its safety parameter. Do not change!
For further information see system description.

Characteristic Curve

Switch points

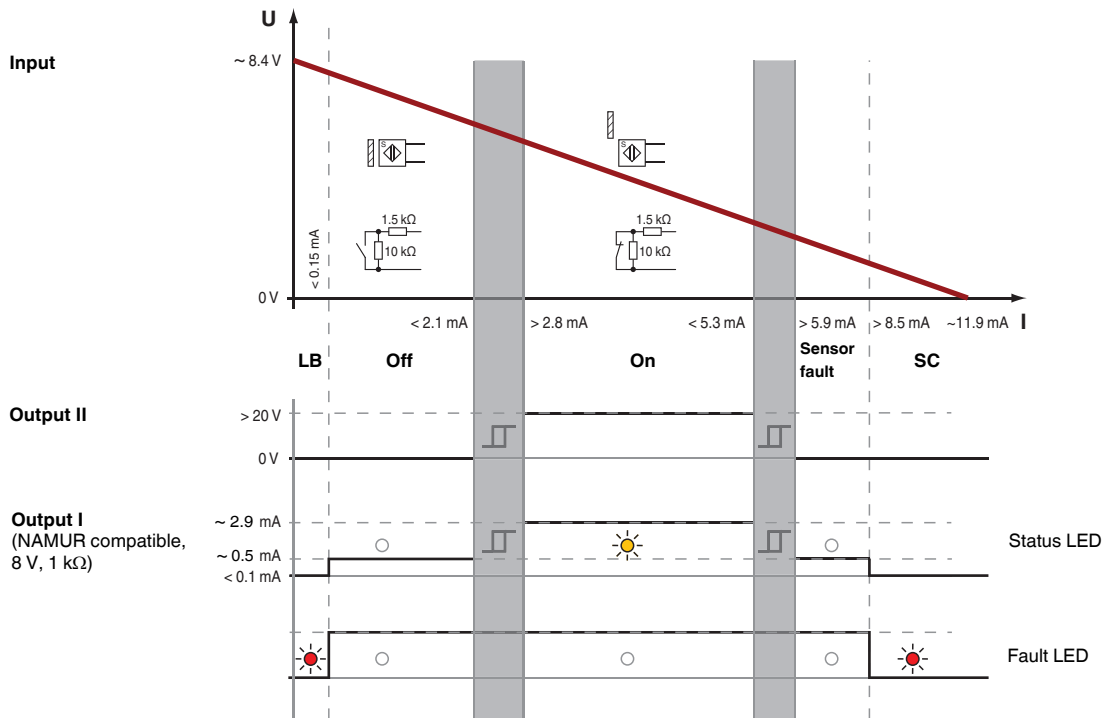

Release date: 2022-09-15 Date of issue: 2022-09-15 Filename: 233599_eng.pdf