



# 1-AVC See-Thru Air Vent

For Pressures to 150 psig (10 barg) or Specific Gravity Down to 0.80

## A See-Thru Body—So You'll Know When It's Working

Now, you can literally see what you've been missing—the early warning signs of a system problem. Since you'll know the operating condition of the air vent, you won't have to waste time and money scheduling maintenance that isn't needed. In other words, you will be able to react to a condition before it becomes a problem.

A simple ball float mechanism requiring no electricity to operate, the new Armstrong 1-AVC discharges automatically only when air/gas are present. That means no liquid loss as with manual venting.

## An Inside Look

See-thru body means you can observe changing conditions as they occur. See a problem in the making—instead of having to deal with it after the fact.

## Efficient Operation

Simple ball float mechanism discharges only when air is present so it doesn't waste liquid.

## Positive Seating

Free-floating valve mechanism assures positive seating so it prevents liquid loss. There are no fixed pivots to wear or create friction, and wear points are heavily reinforced for long life.

## Reduced Maintenance

Stainless steel internals mean corrosion resistance and reduced maintenance.

## Corrosion Resistance

Long-lasting polysulfone body and reinforced nylon cap resist corrosion and provide long, trouble-free service life.

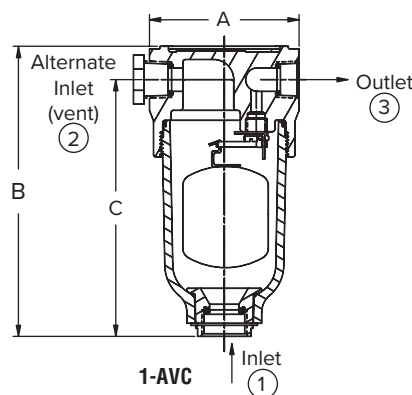

## How to Order

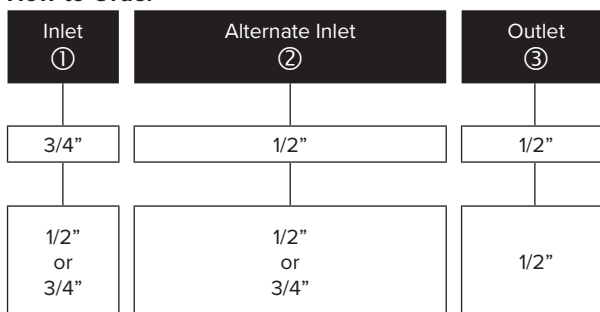

**NOTE:** The Armstrong 1-AVC should not be used in an environment where there are high levels of ketones or chlorinated or aromatic hydrocarbons.

For a fully detailed certified drawing, contact Armstrong.

List of Materials	
Name of Part	Material
Cap	Reinforced Nylon*
Body	Polysulfone
O-Rings (Body Cap and Fitting)	Nitrile Elastomer Compound
Float Lever and Screws	Stainless Steel
Valve & Seat	Stainless Steel
Fitting & Pipe Plug	Reinforced Nylon
Retainer Ring	Zinc Plated Steel

\*UV sensitive.

Physical Data		
	in	mm
Inlet Connection	1/2, 3/4	15, 20
Outlet Connection	1/2	15
"A" Face-to-Face	3-1/2	89
"B" Height	6-3/4	171
"C" Bottom to $\phi$	6	552
Maximum Allowable Pressure (Vessel Design)	150 psig @ 150°F (10 barg @ 65°C)	
Maximum Operating Pressure	150 psig (10 barg)	
Specific Gravity Range	1.00 to 0.80	
Weight, lb (kg)	1 (.45)	

Model 1-AVC Capacity				
Differential Pressure		Orifice Size	scfm	m <sup>3</sup> /hr
psig	barg			
15	1.0	1/8"	4.3	7.3
30	2.0		6.5	11.0
50	3.5		9.5	16.1
75	5.0		13.1	22.2
100	7.0		16.9	28.7
125	8.5		20.5	34.8
150	10.5		24.2	41.3

NOTE: Discharge of air through an orifice in scfm (standard cubic feet of free air per minute) at a standard atmospheric pressure of 14.7 psig (1 barg) and 70°F (21°C).

Designs, materials, weights and performance ratings are approximate and subject to change without notice. Visit [armstronginternational.com](http://armstronginternational.com) for up-to-date information.