



CMP-200

DIGITAL CLAMP-ON AC LEAKAGE CURRENT METER



The CMP-200 digital clamp meter has been designed for clamp measurements of AC leakage current.



Sonel S.A.
ul. Wokulskiego 11
58-100 Świdnica, PL
tel. +48 74 85 83 860
fax +48 74 85 83 809

export@sonel.pl
www.sonel.pl

CMP-200

• **AC current measurement up to 200A.**

- high resolution (0,1mA),
- three measuring ranges: 200mA, 2A, 200A.

The most important features of CMP-200 are:

- display LCD 3½ digits (max 1999),
- white LED backlight,
- internal diameter clamp approx. 30mm (1,2”),
- „DATA HOLD” function, for holding measured values.
- „MAX” function,
- „AUTO-OFF” function,
- double molded casing.

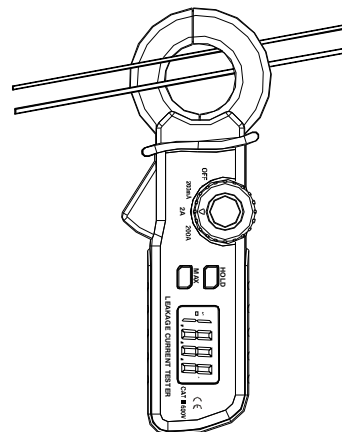

Rys. 1. Leakage current measurements.

AC current measurement

Range	Resolution	Accuracy
199,9 mA	0,1 mA	±(5% m.v. + 8 digits)
1,999 A	0,001 A	±(5% m.v. + 10 digits)
199,9 A	0,1 A	±(2,5% m.v. + 10 digits)

„m.v.” - measured value

Electric security:

- type of insulation double, according to EN 61010-1 and IEC 61557
- measurement category CAT II 600V acc. to EN 61010-1:2004
- protection class acc. to EN 60529 IP40

Other technical data:

- power supply 1,5V AAA battery (2 pcs.)
- over range indication OL displayed
- sampling rate 2 times per second
- display 1999 counts LCD, 3½ digits
- dimensions 182 x 61 x 34 mm
- weight (including batteries) 225 g
- auto power OFF 15 min.
- accordance with following standards EN 61010-1:2004
EN 61010-2-032
- quality standard ISO 9001

Rated operational conditions:

- operating temperature and humidity 0...+30°C (max 90%)
30...40°C (max 75%), 40...50°C (max 45%)
- storage temperature -25...+60°C max <90%
- operating altitude max 3000m

Standard accessories:

- 1,5V battery type AAA (2 pcs.)
- operating manual

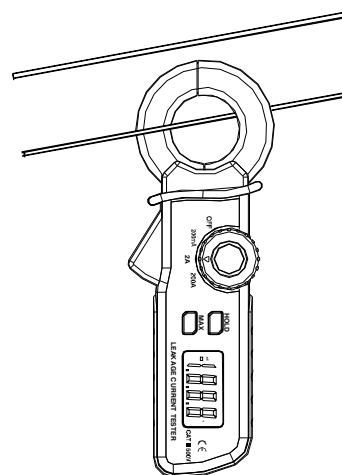

Rys. 2. Load current measurements.

