



Switch Amplifier

HiD2844

- 4-channel isolated barrier
- 24 V DC supply (bus powered)
- Dry contact or NAMUR inputs
- 4 passive transistor outputs
- Line fault detection (LFD)
- Up to SIL 2 acc. to IEC/EN 61508



SIL 2



Function

This isolated barrier is used for intrinsic safety applications. It transfers digital signals (NAMUR sensors/mechanical contacts) from a hazardous area to a safe area.

The proximity sensor or switch controls a passive transistor for the safe area load. The module output changes state when the input signal changes state. The normal output state can be reversed with the selector switches on the side of the unit.

Line fault detection (LFD) can be selected or disabled via a selector switch.

During an error condition, the transistor reverts to its de-energized state and the LEDs indicate the fault. A separate fault output bus is available. The fault conditions can be monitored via a Fault Indication Board.

This module mounts on a HiD Termination Board.

Connection

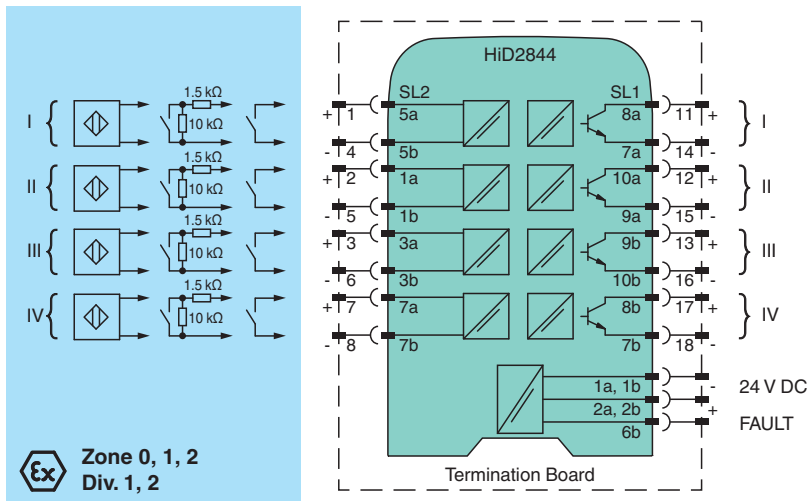

Ex Zone 0, 1, 2
Div. 1, 2

Release date: 2022-05-06 Date of issue: 2022-05-06 Filename: 70124763_eng.pdf

Refer to "General Notes Relating to Pepperl+Fuchs Product Information".

Pepperl+Fuchs Group
www.pepperl-fuchs.com

USA: +1 330 486 0002
pa-info@us.pepperl-fuchs.com

Germany: +49 621 776 2222
pa-info@de.pepperl-fuchs.com

Singapore: +65 6779 9091
pa-info@sg.pepperl-fuchs.com

PF PEPPERL+FUCHS

Configuration

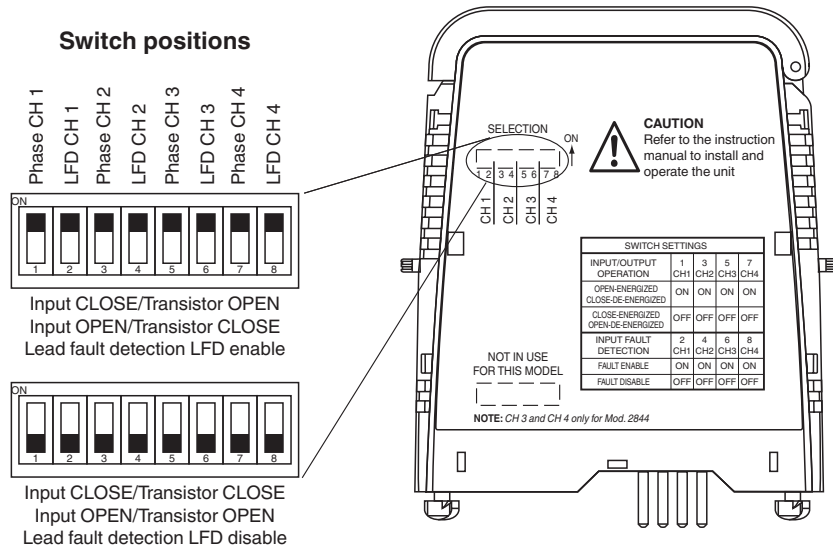

Technical Data

General specifications		
Signal type		Digital Input
Functional safety related parameters		
Safety Integrity Level (SIL)		SIL 2
Supply		
Connection		SL1: 1a(-), 1b(-); 2a(+), 2b(+)
Rated voltage	U_r	19 ... 30 V DC bus powered via Termination Board
Rated current	I_r	55 mA at 24 V
Power dissipation		1.3 W at 24 V
Input		
Connection side		field side
Connection		SL2: 5a(+), 5b(-); 1a(+), 1b(-); 3a(+), 3b(-); 7a(+), 7b(-)
Rated values		acc. to EN 60947-5-6 (NAMUR)
Open circuit voltage/short-circuit current		approx. 10 V DC / approx. 8 mA
Switching point/switching hysteresis		1.2 ... 2.1 mA / approx. 0.2 mA
Line fault detection		breakage $I \leq 0.1$ mA , short-circuit $I \geq 6.5$ mA
Pulse/Pause ratio		min. 250 μ s / min. 250 μ s
Output		
Connection side		control side
Connection		SL1: 8a(+), 7a(-); 8b(+), 7b(-); 10a(+), 9a(-); 9b(+), 10b(-)
Rated voltage	U_r	30 V
Rated current	I_r	50 mA
Output		one optocoupled transistor per channel , short-circuit protected
Signal level		1-signal: (external voltage) -1.3 V 0-signal: blocked output (off-state current max. 50 μ A, typical 5 μ A)
Fault indication output		
Connection		SL1: 6b
Output type		open collector transistor (internal fault bus)
Transfer characteristics		

Release date: 2022-05-06 Date of issue: 2022-05-06 Filename: 70124763_eng.pdf

Technical Data

Switching frequency		< 2 kHz
Galvanic isolation		
Input/Output		basic insulation according to IEC/EN 61010-1, rated insulation voltage 300 V _{eff}
Input/power supply		basic insulation according to IEC/EN 61010-1, rated insulation voltage 300 V _{eff}
Output/power supply		basic insulation according to IEC/EN 61010-1, rated insulation voltage 50 V _{eff}
Output/Output		basic insulation according to IEC/EN 61010-1, rated insulation voltage 50 V _{eff}
Indicators/settings		
Display elements		LEDs
Control elements		DIP switch
Configuration		via DIP switches
Labeling		space for labeling at the front
Directive conformity		
Electromagnetic compatibility		
Directive 2014/30/EU		EN 61326-1:2013 (industrial locations)
Conformity		
Electromagnetic compatibility		NE 21:2017 EN 61326-3-2:2018 For further information see system description.
Degree of protection		IEC 60529:2001
Protection against electrical shock		UL 61010-1:2012
Ambient conditions		
Ambient temperature		-20 ... 60 °C (-4 ... 140 °F)
Mechanical specifications		
Degree of protection		IP20
Mass		approx. 140 g
Dimensions		18 x 114 x 130 mm (0.7 x 4.5 x 5.1 inch) (W x H x D)
Mounting		on Termination Board
Coding		pin 1 and 2 trimmed For further information see system description.
Data for application in connection with hazardous areas		
EU-type examination certificate		CESI 21 ATEX 017
Marking		⊕ II (1)G [Ex ia Ga] IIC ⊕ II (1)D [Ex ia Da] IIIC ⊕ I (M1) [Ex ia Ma] I
Input		Ex ia
Voltage	U _o	13.2 V
Current	I _o	20 mA
Power	P _o	66 mW
Supply		
Maximum safe voltage	U _m	250 V AC (Attention! U _m is no rated voltage.)
Galvanic isolation		
Input/input		safe electrical isolation acc. to IEC/EN 60079-11, voltage peak value 60 V
Input/Output		safe electrical isolation acc. to IEC/EN 60079-11, voltage peak value 375 V
Input/power supply		safe electrical isolation acc. to IEC/EN 60079-11, voltage peak value 375 V
Directive conformity		
Directive 2014/34/EU		EN IEC 60079-0:2018 , EN 60079-11:2012
International approvals		
CSA approval		CoC 80097459 (cCSAus)
Control drawing		116-0487 (cCSAus)
IECEx approval		
IECEx certificate		IECEx CES 21.0011
IECEx marking		[Ex ia Ga] IIC , [Ex ia Da] IIIC , [Ex ia Ma] I
General information		
Supplementary information		Observe the certificates, declarations of conformity, instruction manuals, and manuals where applicable. For information see www.pepperl-fuchs.com .

Release date: 2022-05-06 Date of issue: 2022-05-06 Filename: 70124763_eng.pdf

Refer to "General Notes Relating to Pepperl+Fuchs Product Information".

Pepperl+Fuchs Group
www.pepperl-fuchs.comUSA: +1 330 486 0002
pa-info@us.pepperl-fuchs.comGermany: +49 621 776 2222
pa-info@de.pepperl-fuchs.comSingapore: +65 6779 9091
pa-info@sg.pepperl-fuchs.com

PEPPERL+FUCHS

Assembly

Front view

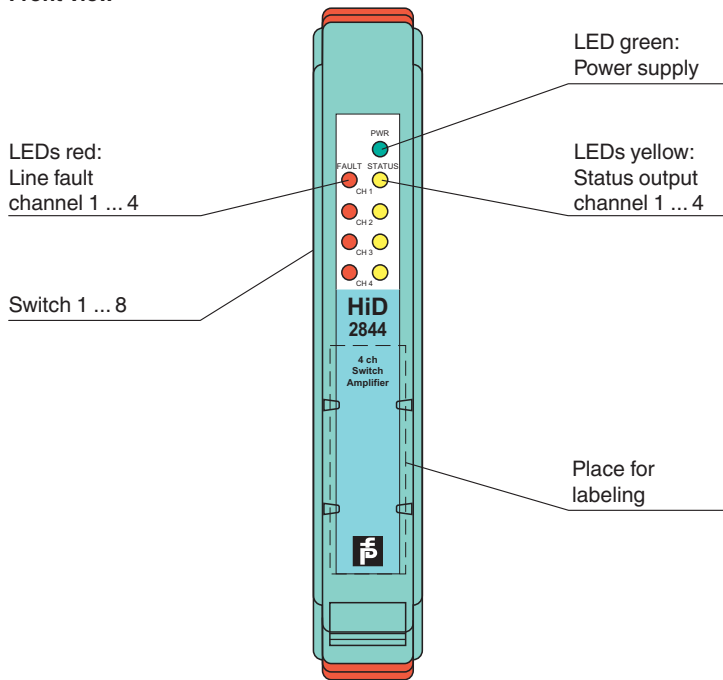

Release date: 2022-05-06 Date of issue: 2022-05-06 Filename: 70124763_eng.pdf

Refer to "General Notes Relating to Pepperl+Fuchs Product Information".

Pepperl+Fuchs Group
www.pepperl-fuchs.com

USA: +1 330 486 0002
pa-info@us.pepperl-fuchs.com

Germany: +49 621 776 2222
pa-info@de.pepperl-fuchs.com

Singapore: +65 6779 9091
pa-info@sg.pepperl-fuchs.com

Configuration

Configure the device in the following way:

- Push the red Quick Lok Bars on each side of the device in the upper position.
- Remove the device from Termination Board.
- Set the DIP switches according to the figure.



*The pins for this device are trimmed to polarize it according to its safety parameter. Do not change!
For further information see system description.*