



Vertical balancing machines for the aircraft industry
航空工业用立式平衡机

VUB50/GV/AERO
(Max. tool + part weight 50Kg)

VUB50/GV/AERO型平衡机
(适于平衡包括工装在内的重量不超过50公斤的工件)



- Vertical axis machines, for balancing single stage low and high pressure turbines.
- Measuring of the dynamic unbalance.
- Spindle fitting suitable for manual clamping tools.
- Protection with electric drive at controlled speed.
- Rotor dimensions from Ø 650 up to Ø 1500

- 适于平衡低和高转速的立式平衡机。
- 可测量不平衡量。
- 主轴连接装置适用于手动固定方式的夹具。
- 速度可控的防护罩。
- 适于平衡直径在650至1500mm内的工件。

VEBN200/GV/AERO
(Max. tool + part weight 200Kg)

VEBN200/GV/AERO型平衡机
(适于平衡包括工装在内的重量不超过200公斤的工件)

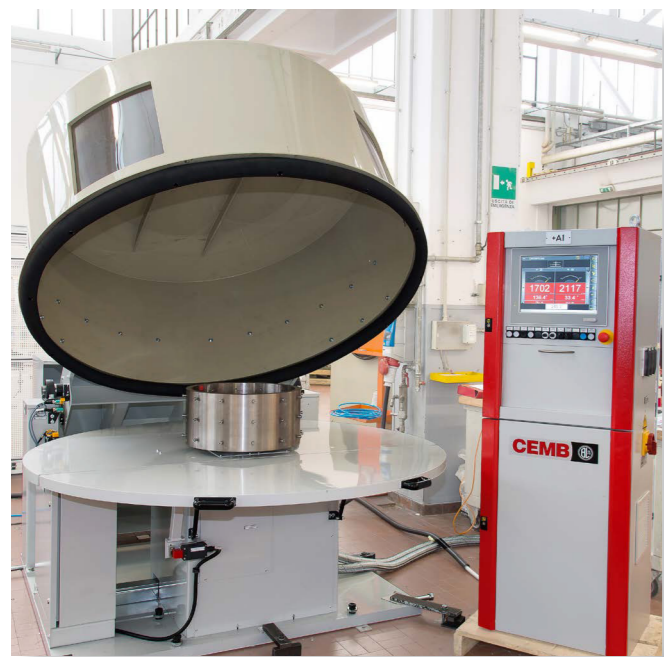

CEMB
BALANCING MACHINES



CEMB S.p.A.
Via Risorgimento, 9
23826 MANDELLO DEL LARIO (LC) Italy
www.cemb.com

Industrial balancing division:
phone +39 0341 706111
fax +39 0341 735678
Italy e-mail: industry.it@cemb.com
Export e-mail: industry@cemb.com



TIRGAN
VIBRATION ANALYSIS & CONDITION MONITORING EQUIPMENT
Address: Unit 6, No. 52, Jouybar St.
Tehran - 1415795361, IRAN
Tel: +98-21-88996358-60 Fax: +98-21-88992367
www.cemb-iran.com
info@cemb-iran.com

AIHS 03 3 20 07/15 www.digimediasas.it

All the data and features mentioned in this catalogue are purely for information and do not constitute any commitment on the part of our company, which reserves the right to make any and all alterations it may consider suitable without notice.

Balancing machines
for the aircraft industry

航空工业用平衡机



CEMB
BALANCING MACHINES



For the manufacturing and maintenance of aircraft engines, CEMB offer a wide range of horizontal and vertical machines to balance aircraft rotors assemblies that weigh between 2 and 5000 kg (tooling included), with a guarantee to achieve maximum accuracy and reliability.

CEMB公司可提供专门用于飞机发动机制造和维修的多种卧式和立式平衡机，适用于平衡重量（包括工装）从2公斤到5000公斤范围内的发动机转子总成，具有极高的测量精度和可靠性。

ZBK200/TO/S/AERO automatic correction

Machine Specifications:

- Hard bearing pedestals with piezo electric pick-up;
- Belt drive system with automatic positioning;
- Automatic correction of the unbalance by milling;
- "Easy Change System" for fast and simple in production.



具有自动修正功能的ZBK200/TO/S/AERO型平衡机

技术性能:

- 安装有内置式力测量压电型传感器的硬支撑平衡机支架；
- 具有自动定位功能的皮带传动系统；
- 以铣削方式自动修正不平衡量；
- “简便换型系统”保证产品换型的快速和简便。

Main advantages:

- A single station machine for the complete balancing process without the need to transfer the rotor between measuring and correction stations, thus avoiding mistakes and significantly reducing cycle time.
- A stable, strong and secure rotor clamping system avoiding any vibration during the milling cycle and creating a perfect surface finishing.
- "Easy Change System" the ball guides, linear scale, labels and fastening pins enable easy and fast rotor type change, plus a more secure and ergonomic operation for the machine operator.

主要优势:

- 整个平衡和修正操作均在同一个工位上完成，无需将工件在平衡工位和修正工位之间进行传送，因此减少操作失误并大大降低周期时间。
- 工件夹具稳定性好、结实安全，避免铣削时产生振动，令工件的加工面美观、光洁度高。
- “简便换型系统”包括滚珠导轨、线性标尺、工件型号标牌和固定销，不仅保证工件的换型快捷省时，而且令换型操作更加安全省力。

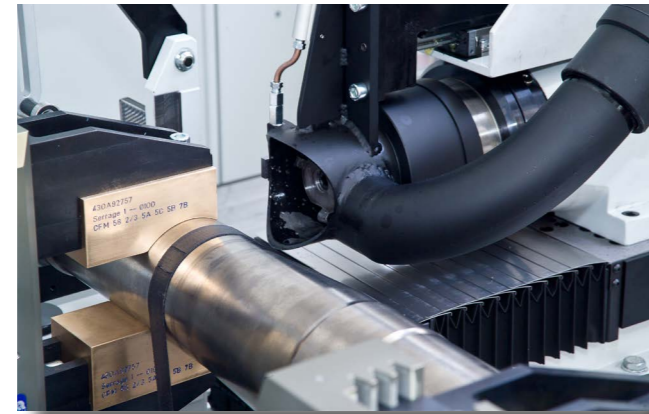
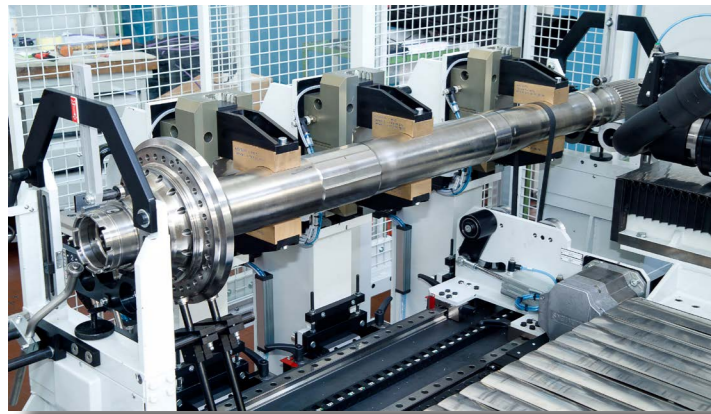
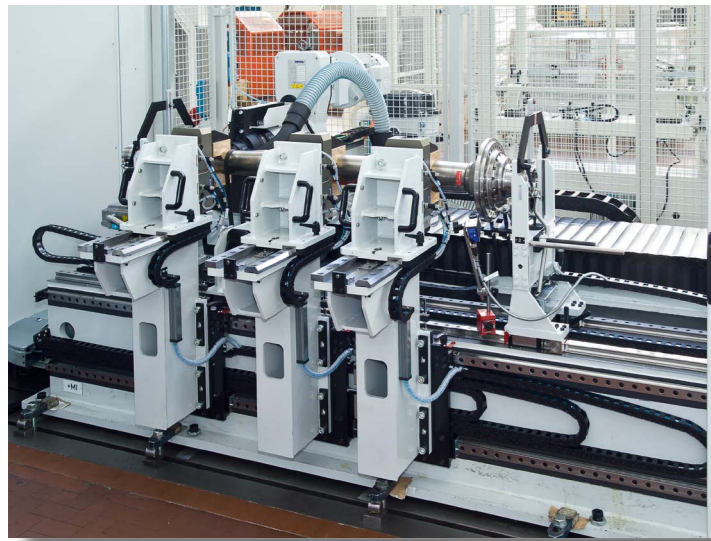

ZB300/TCI/GV/S

- Hard bearing pedestals with piezo electric pick-up;
- Rollers carriages or SAE 13" saddles;
- Belt drive - power Kw 7,5 variable speed;
- Max. capacity of 300 kg tooling included.



ZB300/TCI/GV/S型平衡机

- 安装有内置式力测量压电型传感器的硬支撑平衡机支架；
- 滚轮式工件托架或者 SAE 13" 标准的鞍形工件托架；
- 皮带驱动系统，功率为7.5千瓦的可调速电机；
- 最大平衡重量（包括工装）为300公斤。

ZB2000/G/GV/AERO

- Hard bearing pedestals with piezo electric pick-up;
- Rollers carriages or SAE 13" saddles;
- Cardan drive - power Kw 27 variable speed;
- Max. capacity of 2000 kg tooling included;
- Automatic displacement of the two supports on the bedplate.

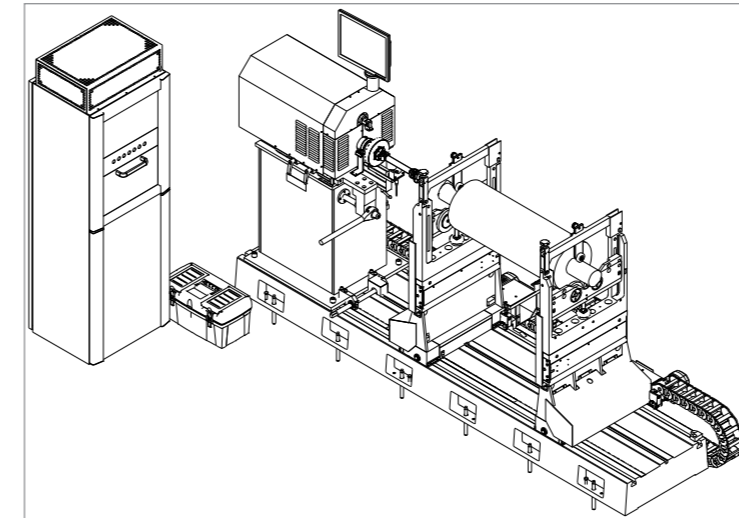

ZB2000/G/GV/AERO型平衡机

- 安装有内置式力测量压电型传感器的硬支撑平衡机支架；
- 滚轮式工件托架或者 SAE 13" 标准的鞍形工件托架；
- 万向节驱动系统，功率为27千瓦的可调速电机；
- 最大平衡重量（包括工装）为2000公斤；
- 自动调节底座上两个支架之间的距离。



ZB5000/G/GV/AERO

- Hard bearing pedestals with piezo electric pick-up;
- Carriages with SAE 20" saddles;
- Cardan drive with coaxial motor - power 250 Kw variable speed;
- Axial displacement of spindle/cardan shaft;
- Disc stationary brake with hydraulic control;
- Max. capacity 5000 Kg tooling included.
- Assembling tools: rotor/stator groups Cemb manufactured.

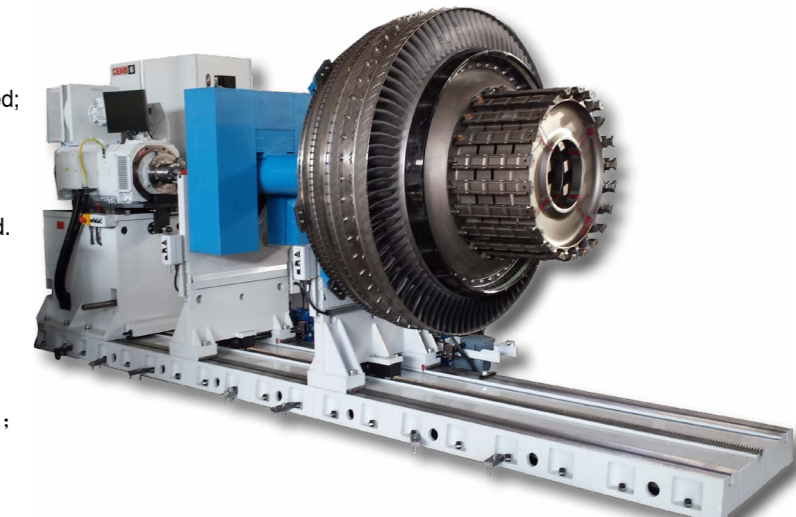

ZB5000/G/GV/AERO型平衡机

- 安装有内置式力测量压电型传感器的硬支撑平衡机支架；
- SAE 20" 标准的鞍形工件托架；
- 万向节驱动系统与可调速电机同轴，电机功率为250千瓦；
- 主轴/万向轴的轴向位置可以调整；
- 制动盘的静态制动为液压控制；
- 最大平衡重量（包括工装）为5000公斤；
- 由CEMB公司制造的安装工装和定子/转子组件。

BALANCING TOOLS

Cemb can supply special high precision tooling for balancing aero rotors. The picture below shows the balancing of a low pressure compressor.

平衡工装

CEMB公司可为飞机发动机转子的平衡提供高精度专用工装。下图为对一个低压空压机进行平衡。

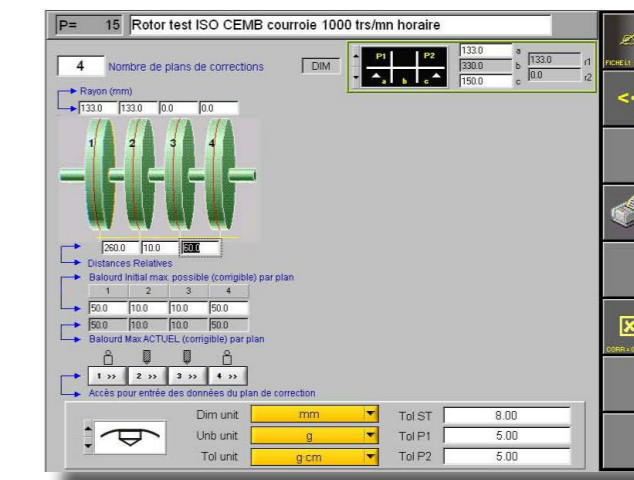
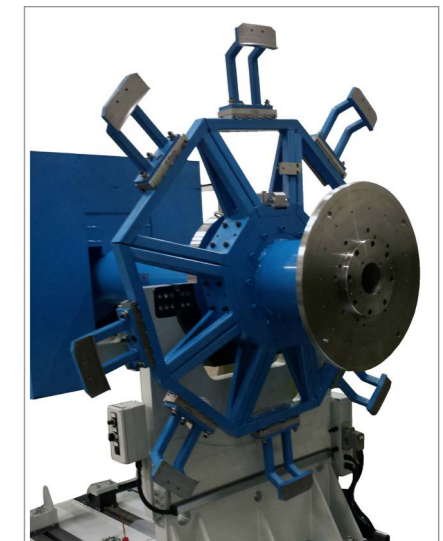
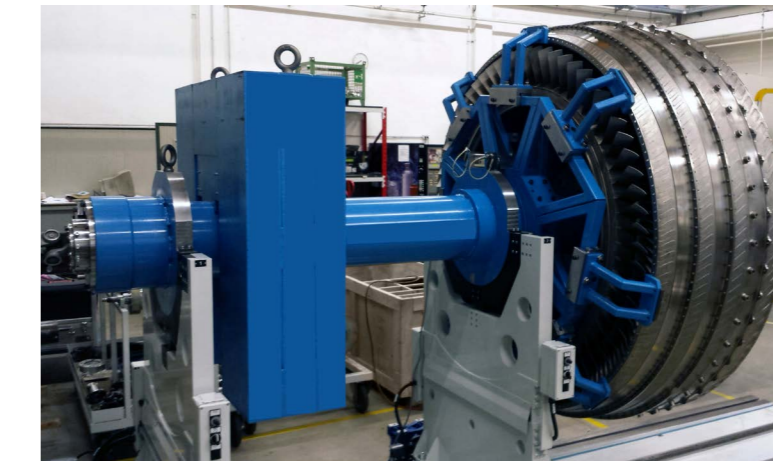

Software for Aeronautical Field

The measuring instrumentation is supplied with specific and dedicated software for the aero industry, suitable for balancing rotors in multi-plane mode (from 2 up to 12 planes) and capable of calculation and graphic representation.

航空领域专用平衡软件

平衡机的测量控制系统包含专为航空领域研制开发的平衡软件，适于在多修正面模式下（2至12个修正面）对工件进行平衡，可以计算出不平衡量并以不同图形对不平衡量加以显示。