



Low pressure flow rate 10 litres/min up to 70 Bar

High pressure flow rate 1.3 litres/min

Working pressure 700 Bar

C

The HPP range of two stage petrol engine driven hydraulic pumps is ideally suited for applications in locations where there is no electricity or compressed air supply available. The range has similar reservoir and valve options (excluding solenoid valves) as electric and air powered pumps. All models are 700 Bar maximum working pressure and offer a low pressure flow rate of 10 litres/min with automatic changeover to a high pressure flow rate of 1.3 litres/min. Powered by a 3.35 kW rated four stroke engine, the HPP range provides reliable, independent hydraulic power. All models are fitted with a protective roll bar carrying frame for easy transportation and handling. A full range of system components suitable for use with HPP pumps is detailed on pages 51 - 60.

- >> Two stage hydraulic pump unit
- >> Powerful 3.35 kW four stroke petrol engine
- >> Externally adjustable pressure relief valve
- >> Roll bar protection frame included
- >> Manual valve with load holding feature fitted as standard

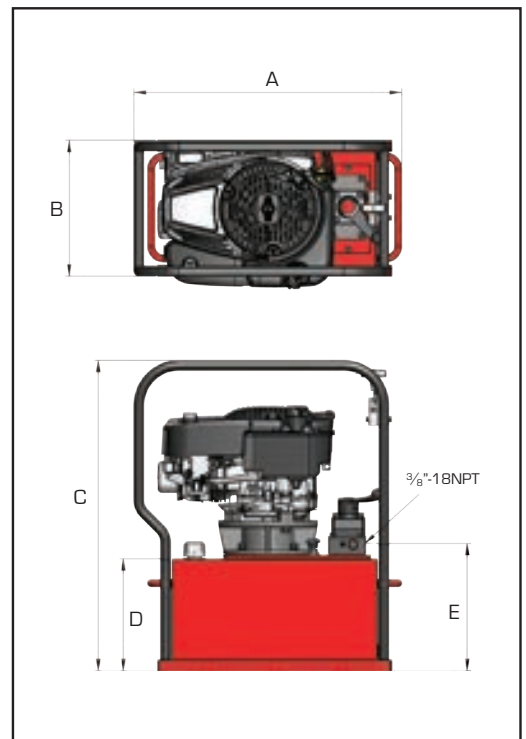

Model number	Valve type	Oil cap. litres	Motor kW	Weight kg
HPP21012	P-T Plate	25	3.35	70.5
HPP21014	P-T Plate	40	3.35	85.5
HPP21016	P-T Plate	60	3.35	113.5
HPP21022	2-way	25	3.35	71.0
HPP21024	2-way	40	3.35	86.0
HPP21026	2-way	60	3.35	114.0
HPP21032	3-way	25	3.35	71.0
HPP21034	3-way	40	3.35	86.0
HPP21036	3-way	60	3.35	114.0
HPP21042	4-way	25	3.35	71.0
HPP21044	4-way	40	3.35	86.0
HPP21046	4-way	60	3.35	114.0

Dimensions in mm				
A	B	C	D	E
570	306	686	227	259
570	306	795	336	368
583	406	816	357	389
570	306	686	227	259
570	306	795	336	368
583	406	816	357	389
570	306	686	227	259
570	306	795	336	368
583	406	816	357	389
570	306	686	227	259
570	306	795	336	368
583	406	816	357	389