

Contents

VIBROCONTROL 1100 C01 / C02 / C11 / C12

- 1 Overview
- 2 Technical Data
- 3 Connectors and Interfaces
- 4 Built-in Operating Panel and Display
Error messages
- 5 List of Setup Parameters
- 6 Installation and Commissioning

Instrument types - Overview

Instrument Type	Supply Voltage	Bearing Condition
VC 1100 C01	230 V AC 115 V AC	YES
VC 1100 C02	24 V DC	YES
VC 1100 C11	230 V AC 115 V AC	NO
VC 1100 C12	24 V DC	NO

The instrument types C01, C02, C11 and C12 listed in the table above are described in the VIBROCONTROL 1100 documentation.

Apart from the bearing condition, which is not applicable to the instrument types C11 and C12, the descriptions for all instruments are the same.

1 Overview

VIBROCONTROL 1100 is a 2 channel microprocessor controlled machine condition monitor. Vibration velocity transducers or vibration acceleration transducers (accelerometers) are used to sense the vibrations from a machine.

VIBROCONTROL 1100 is a compact machine monitor. All components, like power supply, connectors, signal conditioners, microprocessor and operator panel are integrated to one splash-proofed housing.

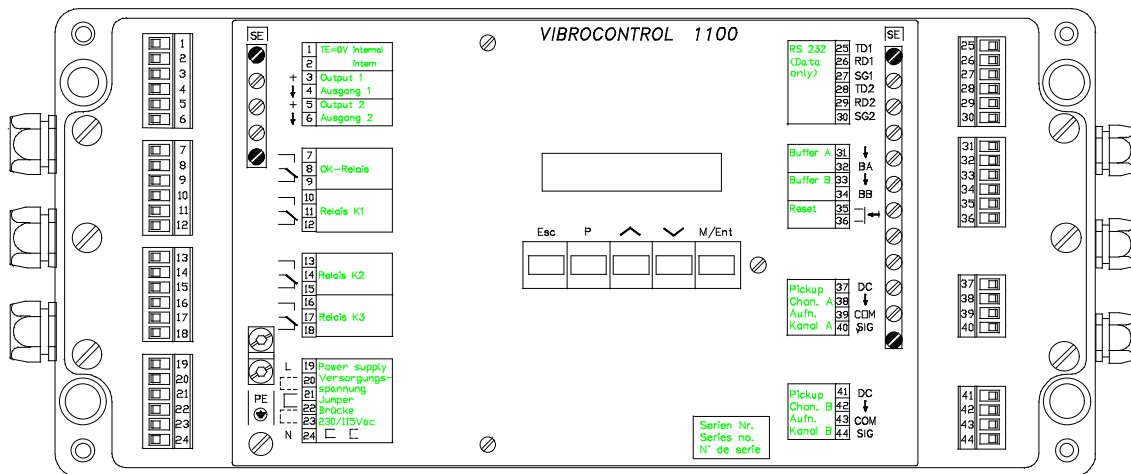

Figure 1-1: Top view of a VIBROCONTROL 1100 with cover removed

VIBROCONTROL 1100 is complete; there are no options. Three alarm relays, one OK-relay, two analog outputs, two buffered outputs, remote I/O interface, and signal conditioners are built-in.

There are no jumpers or potentiometers. All functions are completely microprocessor controlled and are configured using the built-in operator panel or via the remote interface with a computer or process controller.

The wiring is done through removable terminal strip connectors.

Vibration analyzers or data collectors can be connected to the buffered outputs without interrupting the monitoring functions.

Measured Values

Displayed Parameters

The measured values can be displayed in metric or English units:

Measured Parameter	Abbreviation	Unit
Vibration Displacement	s	mm mils
Velocity	v	mm/s ips
Vibration Acceleration	a	g m/s ²

If accelerometers are used, the Bearing Condition of rolling element bearings can be measured and monitored. The unit for Bearing Condition is BCU.

Bearing Condition	- - -	BCU
-------------------	-------	-----

BCU Scaling Factor

Due to the BCU scaling factor, the BCU measuring result can be multiplied with a factor. This factor is determined with parameter J19 for channel A and J20 for channel B in the range between 0.1 and 10. Factor 1 displays the measuring result not scaled.

The BCU scaling factor makes it possible to set the measuring result to a defined initial value in order to compare several measuring points. The BCU scaling factor is to be employed preferably with new bearings.

Note:

The selected scaling factor must be considered when setting the BCU limit value. If for instance the measuring result is divided by two due to the scaling factor, also the limit value must be divided by two.

Example how to use the BCU scaling factor

In case of BCU measurements, the measuring result depends on various factors, e.g. on the place of the pickup installation, on the type of connection (e.g. tightening torque of the pickup) etc. The consequence may be different measuring results with identical machines and the same bearing condition units.

To enable a clear comparison of the single measuring points (change of the bearing condition over a longer measuring period), by means of the BCU scaling factor (parameters **J19**, **J20**) the measuring results can be set to the same initial value (desired value at the beginning of the measurement) for each measuring point.

Carry out scaling

Input the scaling factor 1 for the respective measuring points.

Acquire the current measuring result.

From the desired BCU initial value and the current measuring result of the respective measuring point, the BCU scaling factor J19 or J20 is calculated with the following formula:

$$J19 = \frac{\textit{desired initial value}}{\textit{current measuring result}}$$

After the parameter input of all scaling factors, the re-spective measuring point must display the **desired BCU initial value**.

BCU averaging

The BCU value may vary depending on the operating conditions of a machine, for example due to varying loading conditions.

A defective anti-friction element which regularly changes its position in such a way that the damaged part comes into contact with the bearing running surface only after several revolutions, will also cause varying BCU values.

Variations of that kind do not allow the conclusion that the bearing is damaged.

The measured value can be averaged by means of a filter with settable time constant (averaging time 10 ... 3600 secs.) in order that these "variations" (which do not represent the normal condition of the machine) don't cause an alarm message.

The bigger the selected averaging time

- the more stable the measured value (particularly important for trend considerations)
- the more delayed the response behaviour of the limit value monitoring.

The averaging be switched on and off separately for channel A and channel B (**parameters J15 ... J18**).

Measuring Ranges

The measuring ranges are microprocessor controlled and can be selected continuously within the limits defined in the following table:

Transducer : Vibration acceleration pick-up
Signal detection : Root mean square value

Measured Parameter	Measuring Range		Unit
	Min	Max	
Vibration Acceleration	0 ... 4.00	0 ... 800	m/s ² g
	0 ... 0.40	0 ... 80.0	
Vibration Velocity	0 ... 5.00	0 ... 999	mm/s ips
	0 ... 0.20	0 ... 40.0	

Transducer : Vibration Velocity pick-up
Signal detection : Root mean square value

Measured Parameter	Measuring Range		Unit
	Min	Max	
Vibration Velocity	0 ... 5.00	0 ... 150	mm/s ips
	0 ... 0.20	0 ... 6.00	
Vibration Displacement	0 ... 50.0	0 ... 333	μm mils
	0 ... 2.00	0 ... 13.3	

Multiply values by 1.41 for peak-values and by 2.82 for peak-to-peak values. The largest acceptable number is 999.

The measuring ranges for BCU-Monitoring are independent of the measuring ranges for vibration monitoring.

Measured Parameter	Measuring Range		Unit
	Min	Max	
Bearing Condition	0 ... 1.00	0 ... 140	BCU

Filters

Machine vibrations are sensed by the vibration velocity transducers or accelerometers. Which pickup to use depends on the application. The following table lists the filters that may be used with the different measured parameters and pickup types:

Measured Parameter	Transducer		Filter
	v	a	
Vibration displacement	x		10 Hz ... 1000 Hz
Vibration Velocity	x	x	1 Hz ... 1000 Hz
	x	x	3 Hz ... 1000 Hz
	x	x	10 Hz ... 1000 Hz
		x	10 Hz ... 10 kHz
Vibration Acceleration		x	3 Hz ... 1000 Hz
		x	10 Hz ... 1000 Hz
		x	3 Hz ... 10 kHz
			10 Hz ... 10 kHz
Bearing Condition		x	15 Hz ... 50 kHz

Transducer : v = Vibration Velocity Transducer
 a = Accelerometer

*) Fulfills the requirements of International Standard ISO 2372

Signal Conditioning and Signal Detection Type

The built-in signal conditioners are microprocessor controlled. Gain factors, filters, and the integrator are set automatically. The settings are determined by the microprocessor from the configuration.

Linearization

The characteristic of vibration velocity transducers is not linear in the lower frequency range, i.e. with frequencies around 10 Hz.

VIBROCONTROL 1100 corrects this nonlinearity with a built-in linearization circuit (Standard $f_0 = 8$ Hz / the special design $f_0 = 15$ Hz is identified by an adhesive label inside the instruments). The result is a linear frequency response characteristic for the total measuring system down to 1 Hz.

The linearization circuit can be activated or deactivated by means of parameter input (IO6).

Settling Time and Cycle Times

Electronic components like amplifiers, filters, etc. need a certain amount of time to provide the correct output signal after the input signal has been switched or changed.

This time is called settling time. Components used to measure low frequencies have longer settling times than components used to measure higher frequencies.

VIBROCONTROL 1100

can be configured as a single channel monitor or a 2 channel monitor.

Single Channel Monitor (Vibration and Bearing Condition)

Operating as a single channel monitor, settling times are not required, since the vibration signal is not switched from channel A to channel B. The configuration, filter characteristic and gain, etc. of the Vibration Signal Conditioner and the Bearing Condition Detector do not need to be changed; therefore the vibration signal is measured continuously.

Cycle Time:	Built-in Display	0.5 s
	Alarm level comparison	0.25 s

2 Channel Monitor (Vibration)

The vibration signals of channel A and B are switched alternately (multiplexed) to the Vibration Signal Conditioner.

For each switch between channel A and B, the Vibration Signal Conditioner is automatically re-configured and settling times are required.

The total time for one measurement consists of the settling time and the measurement time. The measurement time is always 3 seconds.

Outside the measuring times, the current display values of the other channel are frozen, the current measured value, however, is monitored in intervals of 0.25 seconds.

The following table shows the settling times and the cycle times (sum of settling and measuring time) for different functions and setups of the Vibration Signal Conditioner. Different setups can be used for channel A and B. The total cycle time is the sum of the cycle times for channel A and B.

Activated Function	Settling Time	Cycle Time
High Pass Filter: 1 Hz	1.75 s	4.75 s
High Pass Filter: 3 Hz	1.00 s	4.00 s
High Pass Filter.: 10 Hz ISO	1.25 s	4.25 s
High Pass Filter: Special	1.75 s	4.25 s
Integrator	6.00 s	9.00 s
Linearization Circuit:	5.75 s	8.75 s

If more than one function has been selected, the function with the longest settling time determines the total settling time.

2 Channel Monitor (Vibration and Bearing Condition)

Since VIBROCONTROL 1100 is equipped with a Bearing Condition Detector, the measurement of Bearing Condition is independent of the vibration measurement.

The settling time is 2.75 s and the measuring time is 1.25 s.

Monitoring

Each measuring channel has three limit values. Two limit values for monitoring the vibration level, (lim_1 and lim_2), and one limit value for Bearing Condition (lim_b). Each limit value can be set individually.

Each limit value can be set to any value between 10 % and 100 % of the measuring range. Larger or smaller limit values are not accepted and will generate an error message

For each limit value an alarm delay time between 1 and 99 seconds can be selected. Limit value exceedance is only acknowledged if the monitored signal remains above the limit value for a period of time longer than the selected delay time. When acknowledged, the event is entered into the 'Log Book', and if it is configured to do so, the appropriate relay trips

In the 2 channel mode the alarm delay time is related to the measurement cycle of the appropriate channel. Two cases have to be considered:

Case 1

The measured value exceeds the limit value and the alarm delay time is shorter than the remaining measurement time of this cycle. If the measured value stays above the limit value, the alarm event is acknowledged after the alarm delay time.

Case 2

The measured value exceeds the limit value and the alarm delay time is longer than the remaining measurement time of this cycle. At the end of the measurement cycle, the alarm delay time is suspended. If the measured value still exceeds the limit value at the beginning of the next measurement cycle, the alarm delay time is resumed. This procedure is continued until the end of the alarm delay time. At this point the alarm event is acknowledged. In case 2 the alarm delay time is prolonged by the measurement cycle of the other channel.

Log Book

All events are stored in a circular buffer using short notation. This buffer can store up to 99 events.

Events are:

Power Up; limit value exceedance; reset instructions; and internal errors detected by the self monitoring.

If the Log Book capacity is exceeded, the "oldest" event is deleted and all stored events are shifted one position, freeing space to store the new event.

The Log Book can be displayed on the built-in display or read via the remote interface.

Each Log Book entry begins with an "H", (for History) followed by a two digit running number and a 'short' notation of the event.

Example:

H03 K1 Lim1 A

Meaning:

H03	Label of Log Book entry
K1	Relay K1 tripped
Lim1 A	because limit value lim_1 of channel A has been exceeded.

The Log Book is deleted every time the VIBROCONTROL 1100 is powered up. It can also be deleted using the built-in operator panel or via the serial interface.

Relays

Three relays are provided which are activated on alarm exceedance if so programmed.

They are designated as K1, K2, and K3.

Programming the Relays

Relay operation is defined by the setup parameters:

1. Which limit value controls which relay.
2. Latching or Non-Latching Mode.
3. Energized or de-energized Operation.
4. Control a relay by combining several limit values using a logical OR or AND statement.

Comment to 1.

Limit value exceedances can be configured as single events or grouped events.

A configuration that is commonly used is, lim_1A and lim_1B control relay K1, and lim_2A and lim_2B control relay K2.

Comment to 2.

Latching Mode

The relay remains latched (tripped) until it is reset using the control panel, reset switch, or via the remote interface.

Non-Latching Mode

The relay is automatically reset when the measured value drops below the limit value.

Comment to 3.

This choice depends on the user's philosophy. What is important though, is preventing a false relay trip if power to the VIBROCONTROL 1100 is disconnected.

Mode	No Alarm	Alarm
Normally Energized	Relay active	Relay not active
Normally De-Energized	Relay not active	Relay active

Comment to 4.

AND

Several limit values control one relay. This relay is tripped only if all limit values are exceeded.

OR

Several limit values control one relay. This relay is tripped if at least one limit value is exceeded.

Note:

If a measuring channel or a limit value has been set to "not active" ("N") and this limit value is combined with an AND, this logical condition can never become "true". Therefore the alarm indication can never be activated.

OK-Monitoring



The OK-Monitoring is used to report malfunctions and/or data failure of the program and data stores, electric damages or the failure of the pickup and its connection lines. The monitoring covers an "External range recording" of the vibration signal. Errors caused by cable breakage, short circuit or earth fault of the signal lines are recognized, reported and written into the log book.



Since the OK-Relay is normally energized, the messages are output in the operating state network ON/OFF.



System messages such as:

- no calibration data in EEPROM
- no dialog data in EEPROM

will cause an OK-error which can be reset by means of **Relay Reset**.

Important:

When an OK error occurs, all limit relays maintain their current status. After removing the OK error and acknowledging it by "Relay Reset", they perform their normal function again.

In case of a system error message, e.g.

- calibration data not readable (ER -31)
 - no valid calibration data in the EEPROM (ER -37)
- a hardware error is present.



This error can only be eliminated by a Schenck service station or in the parent company.

Inputs and Outputs

Inputs

VIBROCONTROL 1100 accepts vibration velocity transducers or accelerometers.

In 2 channel operation, pickups of the same type with the same sensitivity are required.

Accelerometers (passive transducers) are powered by the internal power supply of VIBROCONTROL 1100.

Outputs

a) Alarm Indication

Alarm level exceedances are indicated by galvanically free relay contacts.

b) Analog-Outputs

Two separate analog outputs are provided for analog meters or strip chart recorders. Which measured parameter is supplied on which analog output is determined during the setup. Each analog output can be configured for either 0 ... 10 V or 0.4 ... 20 mA.

Remote I/O (Serial Interface)

Up to 205 VIBROCONTROL 1100 can be daisy-chained to one serial interface of a computer or process controller. Status, Log Book, and measured values can be read, stored, displayed, printed, etc.

In addition the configuration of each VIBROCONTROL 1100 can be confirmed and modified.

Definitions

Several terms are commonly used for measured vibration parameters. The following is a summary of terms used in this manual.

Signal Detection Type:

Zero-to-Peak Value *)
 Definition: The maximum deviation of the absolute value of the vibration signal from zero.
 Used here: peak or pc
 Other terms: peak-value, amplitude, single amplitude

Signal Detection Type:

Peak-to-Peak Value *)
 Definition: The maximum distance between peak negative and peak positive of the vibration signal.
 Used here: peak-to-peak or ppc
 Other terms: amplitude, double amplitude

Signal Detection Type:

Root-Mean-Square Value
 Definition: The square root of sum of the squared amplitudes over a period of time.
 Describes the energy content of a vibration signal.
 Used here: rms
 Other terms: effective value, true rms value

*) VIBROCONTROL 1100 measures the true rms value. Peak values are calculated from the rms value using the formulae:

Beispiel:

zero-to-peak value = rms value x 1.41 [pc]
 peak-to-peak value = rms value x 2.82 [ppc]

This page has been reserved for your notes.

2 Technical Data



Supply Voltage

- Type VC-1100-C01
Type VC-1100-C11
- 115 V AC or
230 V AC +15 % / -25 %
jumper selectable

Power consumption

48 ... 400 Hz
approx. 15 VA

- Type VC-1100-C02
Type VC-1100-C12
Power consumption
- 24 V DC (16 ... 36 V)
approx. 15 W

Fuses

- Supply Voltage 115/230 V AC
 - Supply Voltage 24 V DC
Transducer supply -24 V
 - EMC Emitted interference
 - Immunity from interferences
- 2 Thermo-Resistors
250 °F (125 °C)
built-in the primary
transformer windings
- NTC - Resistor
2 x 30 mA short-circuit-
proof
- according to EN 50081-1
- according to EN 50082-2

Housing and Operating Conditions

Housing

- Material Aluminium AL Si 12
- Seal type IP 65 (DIN 40050) splash proof (water)
- Dimensions 360 x 160 x 91 mm (LxWxH)
14.2 x 6.3 x 3.6 inch (LxWxH)
- Weight app. 5 kg (11 lbs)
- Cable fittings 9 x PG 9 and 3 x PG 13.5 feed-throughs adapters
PG 9 to 1/2-14 NPT are available
- Paint RAL 7032 (grey)
Top cover RAL 2011 (orange)

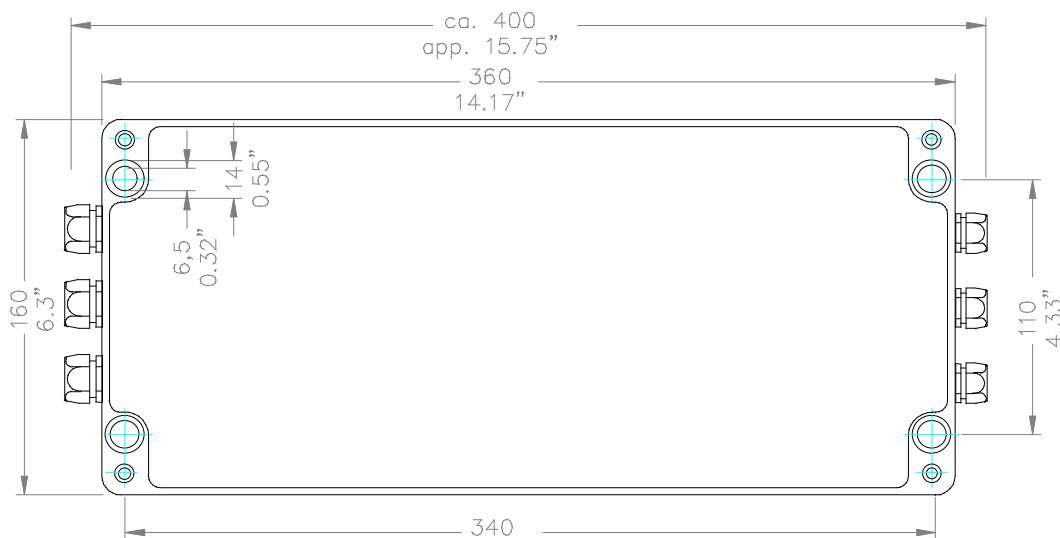

Figure 2-1: Housing Dimensions

Operating Conditions

- Storage Temperature Range -20 ... + 70 °C (4 ... 148 °F)
- Operating Temperature Range 0 ... + 50 °C (32 ... 122 °F)
- Rel. Humidity max. 95 % non condensing

Analog Circuits

Channels	2
Inputs ^{1) 2)}	accept <ul style="list-style-type: none"> a) Vibration Velocity Transducers with a sensitivity of 100 mV/mm/s, $f_o = 8$ Hz, $R_i = 4$ kΩ b) Accelerometer with a sensitivity of 100 mV/g (10.2 mV/m/s²)
Input Impedance	approx. 100 k Ω

Accuracy

(for frequency ranges listed below:)

- Vibration Parameters
 - ± 0.5 % of full-scale plus:
 - ± 4.0 % of the meas. value (1 Hz... 3 Hz)
 - ± 2.0 % of the meas. value (3 Hz... 10 Hz)
 - ± 1.0 % of the meas. value (10 Hz... 100 Hz)
 - ± 2.0 % of the meas. value (1000 Hz...10000 Hz)
- Bearing Condition
 - ± 6 % of the measured value plus or
 - ± 3.5 % of full-scale, whichever is greater

Frequency Range ³⁾

The 10 Hz high-pass and 1000 Hz low-pass filters are of the 3.rd order, and meet the requirements of DIN/ISO 2373, DIN/ISO 3945 and DIN 45 666. All other filters are 2nd order Butterworth filters, with -1 dB damping at specified corner frequencies.

- Vibration Displacement: 10...1000 Hz (v- pickup)

- 1) VIBROCONTROL 1100 accepts 2 pickups of the same type and sensitivity.
- 2) The setup is microprocessor controlled via the built-in operator panel or Remote Interface.
- 3) The respective selection is made software-controlled in dialog mode.

- Vibration Velocity:
 - 1... 1000 Hz (v-or a-pickup)
 - or 3... 1000 Hz (v-or a-pickup)
 - or 10... 1000 Hz (v-or a-pickup)
 - or 10...10000 Hz (a-pickup)

- Vibration Acceleration:
 - 3... 1000 Hz (a-pickup)
 - or 10... 1000 Hz (a-pickup)
 - or 3...10000 Hz (a-pickup)
 - or 10...10000 Hz (a-pickup)

- Bearing Condition: 13 kHz ... 64 kHz- 3 dB (a-pickup)

Measured Parameters and Signal Detection Type ³⁾

- Root-Mean-Square-Value X_{rms} or X_{eff} for s/v/a
- Zero-to-Peak-Value X_{pc} for s/v/a
- Peak-to-Peak-Value X_{ppc} for s/v/a
- Bearing Condition BCU

3) The respective selection is made software-controlled in dialog mode.

4) Ranges between min. and max. are infinitely variable.

Measuring Ranges ^{3) 4)}

The measuring range depends on the selected pickup type, measured parameter, and signal detection type. The range is continuously adjustable within the minimum and maximum values shown in the table.

Pickup	Unit	Measured Parameters and Signal Detection Type					
		rms		pc		ppc	
		min	max	min	max	min	max
a	m/s ²	0... 4.0	0...800.0	0... 6.0	0...999.0	0... 12.0	0...999.0
	g	0... 0.4	0... 80.0	0... 0.6	0...120.0	0... 1.2	0...240.0
	mm/s	0... 5.0	0...999.0	0... 7.5	0...999.0	0... 15.0	0...999.0
	ips	0... 0.2	0... 40.0	0... 0.3	0... 60.0	0... 0.6	0...120.0
v	mm/s	0... 5.0	0...150.0	0... 7.5	0...225.0	0... 15.0	0...450.0
	ips	0... 0.2	0... 6.0	0... 0.3	0... 9.0	0... 0.6	0... 18.0
	mm	0...50.0	0...333.0	0...75.0	0...500.0	0...150.0	0...999.0
	mils	0... 2.0	0... 13.3	0... 3.0	0... 20.0	0... 6.0	0... 40.0

Pickup	Unit	Measuring range	
		min	max
a	BCU	0 ... 1	0 ... 140

Type of pick-ups:
a = vibration acceleration pick-up
v = vibration velocity pick-up

Measuring Cycles

- ◆ Single-Channel-Mode
 - Vibration Displacement 3.0 s
 - Bearing Condition 1.25 s
 - Refresh Display 0.5 s
 - Comparison of limit values 0.25 s

3) The respective selection is made software-controlled in dialog mode.
4) Ranges between min. and max. are infinitely variable.

◆ Dual-Channel-Mode

- Vibration Parameters

Measuring Time per Channel:	3.0 s
Settling Times:	
Filter with a lower frequency corner of 1 Hz	1.75 s
Filter with a lower frequency corner of 3 Hz	1.0 s
ISO-Filter with a lower frequency corner of 10 Hz	1.25 s
Special Filter	1.75 s
Integrator	6.0 s
Linearization Circuit	5.75 s

- Bearing Condition

Measuring Time per Channel:	1.25 s
Setting Time	2.75 s

◆ Analog Output

- Number of Outputs 2³⁾ Resolution: 256 (8 Bit)
 (both outputs independently adjustable)
 Refresh time ca. alle 0.5 s

	0...10 V DC $R_{load} \geq 500 \Omega$ (withstands short circuits)
	or 0...20 mA Load $\leq 500 \Omega$
	or 4...20 mA Load $\leq 500 \Omega$
Error:	U-Output $\pm 1 \%$ of measured value ± 0.1 mV
	I-Output $\pm 2 \%$ of measured value ± 0.2 μ A

- Buffered Outputs

Number of Outputs 2	Output of the pickup signal of each channel with the correct phase. The signal is attenuated by a factor of 0.1
	Source impedance : $\approx 0 \Omega$
	Max. output current : 4 mA
	Resistance : > 10 k Ω
	Max. cable length with cable capacitance of 70 pF/m
	(Wire against wire) : ≤ 16 m

3) The respective selection is made software-controlled in dialog mode.

Microprocessor - System

Storage capacity

RAM	8 kByte
EPROM	64 kByte
EEPROM	2 kByte

Built-in Operator Panel

- 5 push buttons
- LCD, 16 characters, alphanumeric

Storage of setup parameters

in non-volatile EEPROM

Limit values ³⁾

- Total number 6 (3 per channel)
- per channel

1 limit value 1	(lim_1)
1 limit value 2	(lim_2)
1 limit value Bearing Condition	(lim_b)

Relays

- Self-Monitoring 1 OK-Relay to indicate malfunctions detected by the self-monitoring function
- Alarm Level Exceedances 3 Relays K1, K2, K3 to indicate alarm level exceedances ³⁾
- Range of settings for limit values 10 ... 100 % of the corresponding measuring range
- Contacts 2 pole
- Contact Rating

250 V AC, 5 A (Ohm Load, $\cos \varphi = 1$)
250 V AC, 2 A (Inductive Load, $\cos \varphi = 0.4 \dots 0.7$)
24 V DC / 0.4 A
48 V DC / 0.2 A



A spark extinguisher must be installed as close to the spark generator as possible !

³⁾ The respective selection is made software-controlled in dialog mode.

- ◆ Link of limit values to relays
 - Each limit value can be linked only once
 - None or 1 to 6 limit values can be linked to one relay
 - If a relay is linked to several limit values, the limit value exceedances can be combined in two ways:
 - a) AND
The relay trips, if all limit values that are linked to this relay are exceeded.
 - b) OR
The relay trips, if at least one of the limit values linked to this relay is exceeded.

- OK-Relay normally energized
- Alarm relays ³⁾ K1, K2, K3 normally energized or normally de-energized latching or non-latching
- Alarm delay Time ³⁾ can be set individually for each limit value from between 1 and 99 s (accuracy $\pm 5\%$)
- Reset function 1 galvanically free contact switch to reset latched relays.

- ◆ Remote Interface Number of Ports 2 Interface Type RS-232-C (EIA), (Data only)
 - Baud rate ³⁾ 1200, 2400, 4800 or 9600 Parity none Data Bits 8 Stop Bits 1

3) *The respective selection is made software-controlled in dialog mode.*

3 Connectors and Interfaces

Fundamentals



- ◆ All connections including those for power are inside the housing.
- ◆ Feed cables into the housing via feed-through fittings. There is a total of 3 x PG 13.5 and 9 x PG 9 feed-through fittings; 6 on each side.
The threads are PG9, a standard commonly used in Europe. Each VIBROCONTROL 1100 comes with two PG9/PG7 adapters. PG9/1/2"-NPT adapters are also available. Maximum cable size is 1.5 mm² (16 AWG). Use flexible cable only.



- ◆ Cable ends should have crimp ferrules for a proper connection to the removable terminal strips. Remove (unplug) the terminal strips during wiring. VIBROCONTROL 1100 groups the terminal strips in functional blocks (pickups, remote I/O, relays, etc.) and each is coded to prevent mix-ups.



Use shielded cables to suppress external RF noise. This is not necessary for power and relay wiring. Connect all shields to the screw terminals located on top of both sides of the internal housing (SE).



- ◆ Run signal cables a minimum of 0.5 m (20 inches) from power cables. If you must cross a power cable do so at right angles.

By means of steel flexible tubes, protect signal leads from mechanical damage and electrical interferences.

Index of Cable Connections and Interfaces:

Inputs:	Terminal:	Page:
Power	19 ... 24	4
Pickup Channel A	37 ... 40	5
Pickup Channel B	41 ... 44	5
Relay Reset	35 ... 36	6

Inputs:	Terminal:	Page:
Relay 1	10 ... 12	7
Relay 2	13 ... 15	7
Relay 3	16 ... 18	7
OK-Relay	7 ... 9	7
Analog Output 1 Channel A	3 ... 4	9
Analog Output 2 Channel B	5 ... 6	9
Buffered Output Channel A	31 ... 32	10
Buffered Output Channel B	33 ... 34	10
Remote I/O:		
RS-232-C IN	25 ... 30	11
RS-232-C OUT C	28 ... 30	11

Die Anschlüsse im Einzelnen:

Symbols

Folgende Abkürzungen werden verwendet:



TE	=	Technical Earth (Ground)
SE	=	Shield Earth (Ground)
PE	=	Protective Earth (Ground)
↓	=	General Symbol for Reference Level
0VA	=	Analog Circuits
0VD	=	Digital Circuits
L	=	Line Voltage
N	=	Neutral

DC	=	Direct Current/Voltage
AC	=	Alternating Current/Voltage
TD	=	Transmit Data (RS-232-C)
RD	=	Receive Data (RS-232-C)
SG	=	Signal Ground (RS-232-C)
BA	=	Buffered Output Channel A
BB	=	Buffered Output Channel B

TE (0VA) and 0VD can be connected at a central point.

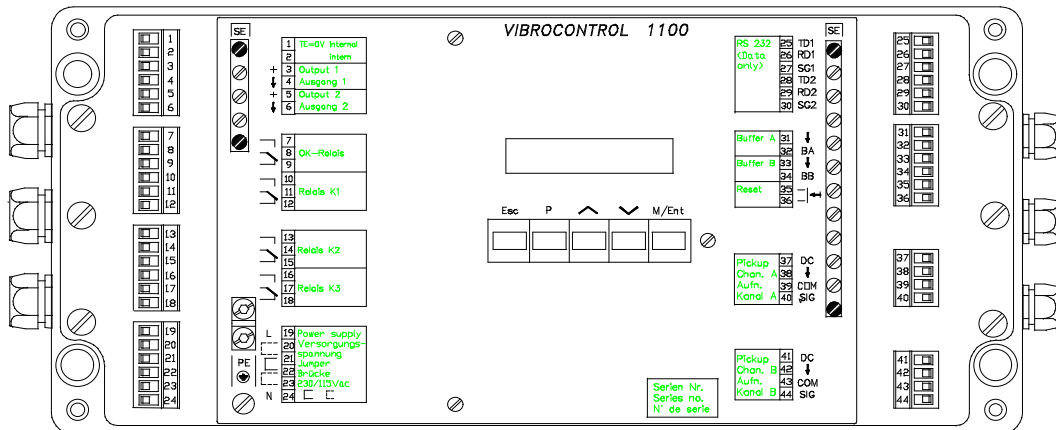

VC11TOTA (951030)

Fig. 3 - 1: Top view of a VIBROCONTROL 1100 with cover removed

Important: Safety Procedures



The safety instructions are attached as a separate brochure in different languages.

The user is responsible for commissioning the VIBROCONTROL 1100 and its placement in the operating environment. Special care should be taken when installing pickups in hazardous areas. Apply safety standards properly.

Inputs

Power Supply



Version

VC 1100 C01/C11
VC 1100 C02/C12

115 V AC Wiring

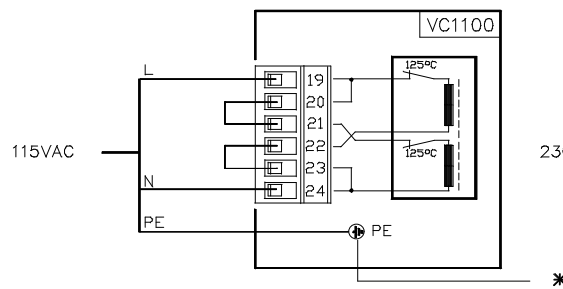

Supply Voltage

230 V AC or 115 V AC
24 V DC

230 V AC Wiring

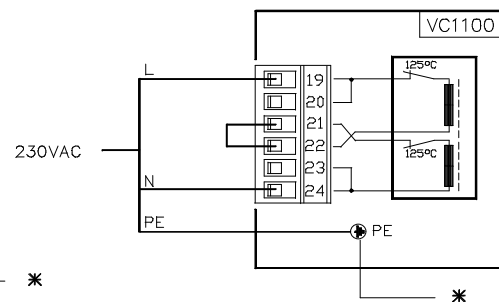

24 V DC Wiring

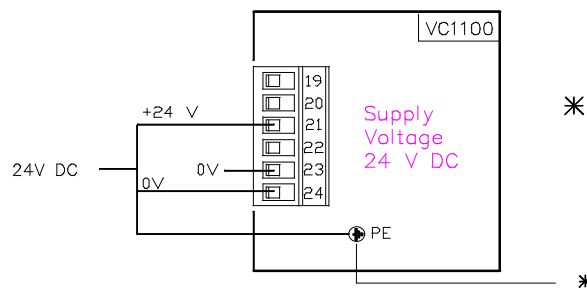

* Connect to terminal 1 or 2 (see general ground recommendations)

KL19-24 E (940921)

Fig. 3 - 2 : Supply Voltage Wiring

Coded Terminal strip 19 - 24 cannot be plugged into any other slot but its own.

Grounding



Connect protective ground of the power cord to the PE terminal located on top of the internal housing.

This is the central grounding point for the housing. This point (PE) is connected to TE by a jumper wire between terminal strip 1/2 and SE. This is the standard configuration.

In special cases, for example if a peripheral instrument is used with internally grounded inputs, open the connection between PE and TE by removing this jumper wire.

Please consult the **General Grounding Recommendation** in this manual.

Pickups

Two types of pickups can be connected:

- a) Vibration Velocity Transducers
- b) Vibration Acceleration Transducers (Accelerometers)



Velocity pickups and accelerometers have different interfaces. The velocity transducer (Type VS - ...) is an active pickup, i.e. it does not require a supply voltage. The cable has two conductors and a shield.

The accelerometer (Type AS - ...) is a passive pickup, i.e. it has a built-in charge amplifier which requires a supply voltage. VIBRO-CONTROL 1100 supplies accelerometers with -24 V DC with a max. current of 30 mA. The cable has 4 conductors and a shield.

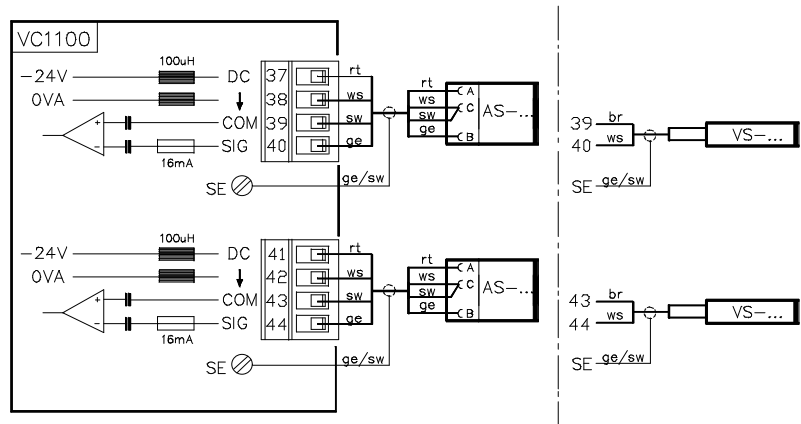

KL37-44 (940718)

Fig. 3 - 3 : Connecting Vibration Velocity and Vibration Acceleration Transducer

rt = red, ws = white, sw = black, ge = yellow, br = brown, ge/sw = yellow/black

Standard pickup cable length is 5 m (16 feet). A maximum cable length of 200 m (600 feet) requires proper installation including appropriate junction boxes and signal cables.

For more information, please consult the manual for the pickup used.

Relay Reset

Use only galvanically free switches with the Relay-Reset Input to manually reset latched relays. Latched relays can also be reset via the operating panel or through the remote interface.

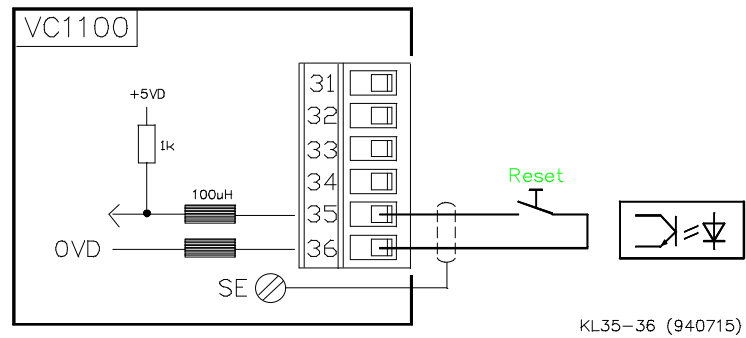

Fig. 3 - 4 : Connection of a galvanically free switch to the Relay Reset-Input

Outputs

Relays



Consider the following if the relay outputs are to be used.

- ◆ Decide if the relays are to be "normally energized" or "normally de-energized". Setup parameters (N10, N11, N12) must be consistent with the wiring. Refer to the examples on the next page.
- ◆ If a relay is configured as latching (see parameters N07, N08, N09) there are three ways to reset it. With the operating panel; via the remote interface; using the Relay-Reset Input
To use the Relay-Reset Input, connect a galvanically free switch to terminals 35 and 36 (see previous page).
- ◆ If conductive loads are connected, provide appropriate spark suppression placed as close as possible to the part that would generate the spark.



Contact Rating: max. 5 A, 220 V AC (Ohmic load)

A spark extinguisher must be installed as close to the spark generator as possible !

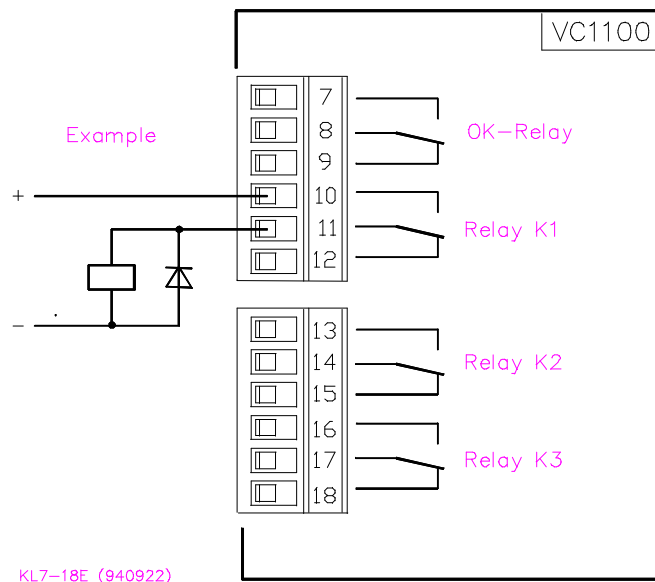

Fig. 3 - 5 : Connecting the-Relays

Figure 3 - 5 shows the contacts in the de-energized position.

Relays



The following diagrams explain the terms

- normally de-energized and
- normally energized

The thicker lines show energized circuits.

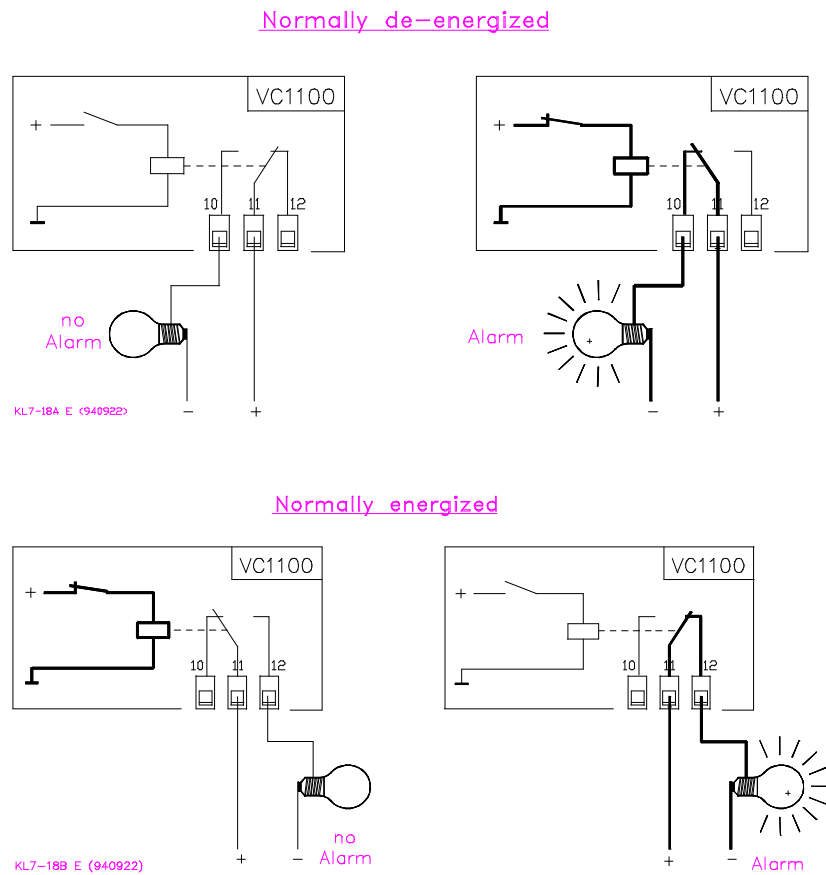

Fig. 3 - 6: *Explanation of the Normally De-Energized and Normally Energized Mode for Relays*

Analog Outputs

The analog outputs are used for example with strip chart recorders and analog meters. These analog outputs are not galvanically free, (isolated) and should only be used with instruments that have galvanically free inputs.

Both analog outputs are independent and of equal design.

Their function depends on how they are configured (see parameters L1, L2, L3, L4).

Example :

Configure analog output 1 for the measured vibration value of channel B "vib_B" using a 4 ... 20 mA signal.

The setup parameters for channel B are:

- Measured Parameter J04: v (vibration velocity)
- Unit J06: mm/s (or ips)s
- Signal Detection J08: rms
- Measured Tange J10: 50.0 (or 2.00)

Using this setup, an output signal of 4 mA corresponds to a vibration level of 0 mm/s (0 ips). An output signal of 20 mA corresponds to a vibration level of 50.0 mm/s (2.00 ips).

Technical Data :

Current Output: 0/4 ... 20 mA Load < 500 Ω

Voltage Output: 0 ... 10 V R_L > 1 k Ω , short-circuit proof

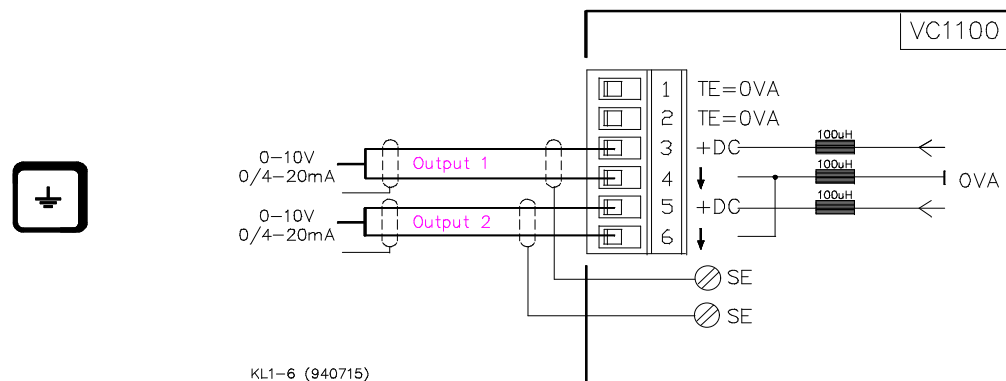

Fig. 3 - 7: Connecting Analog Outputs

Buffered Outputs

The buffered outputs provide the pickup signals for on site analysis or data collection. The signal is attenuated by a factor of 0.1. The buffer amplifier strips off the DC part of the pickup signal.

Max. output current I_{max}	:	4 mA
Ohmic load R_L	:	> 10 k Ω
Max. cable length with cable capacity of 70 pF/m (Wire against wire)	:	\leq 16 m

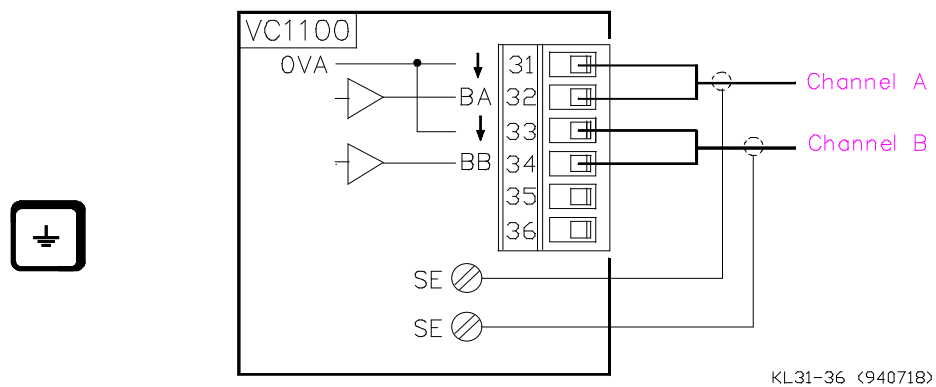

Fig. 3 - 8: Connecting to the Buffered Outputs for On Site Analysis

Remote I/O

VIBROCONTROL 1100 has two RS-232C serial interfaces. Hardware handshakes are not required for communication with process controllers or personal computers (HOST). This reduces the number of cable conductors required.

Cables should be shielded with two twisted pairs. The Remote Interface provides a means to interrogate and modify the configuration as well as obtain the measured values from up to 205 daisy-chained VIBROCONTROL 1100's.

VIBROCONTROL 1100 can be connected to a HOST in two different ways:

a) A HOST communicating with one VC-1100 for 25-pole Sub-D Plug

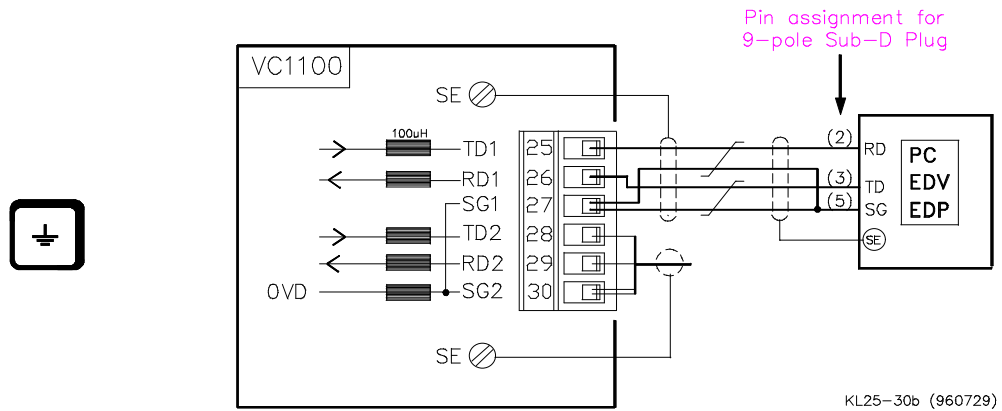

Fig. 3 - 9: Interfacing a HOST with one VC-1100

b) A HOST communicating with one VC-1100 for 9-pole Sub-D Plug

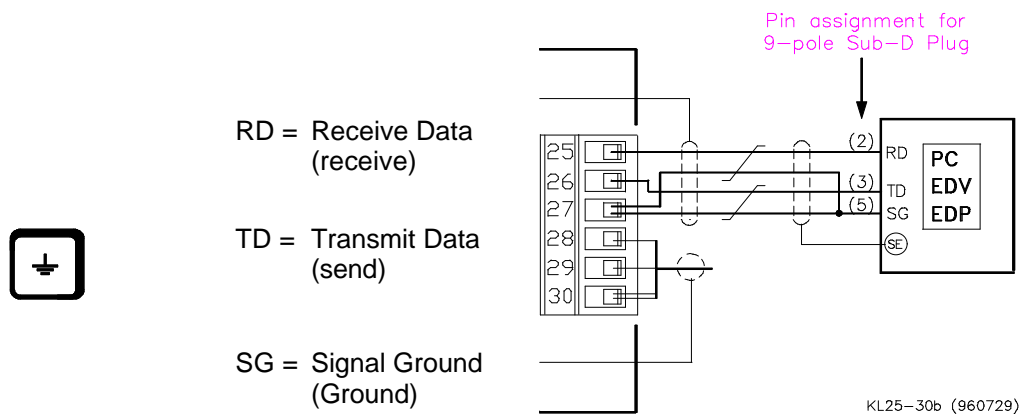

Fig. 3 - 10: Interfacing a HOST with one VC 1100

c) A HOST Communicating with Several VIBROCONTROL 1100

The HOST can control up to 205 daisy-chained VIBROCONTROL 1100's with one serial interface on the HOST.

Each VIBROCONTROL 1100 has a unique address. If a VIBROCONTROL 1100 does not receive its unique address, it passes the message to the next unit. If one unit is removed, the daisy-chain must be closed as shown in figure 10.

For more information, please consult the "Remote I/O" chapter in this manual.

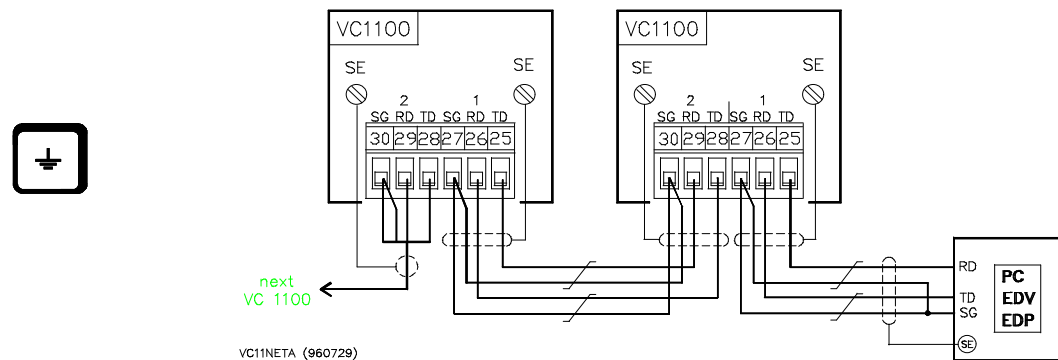
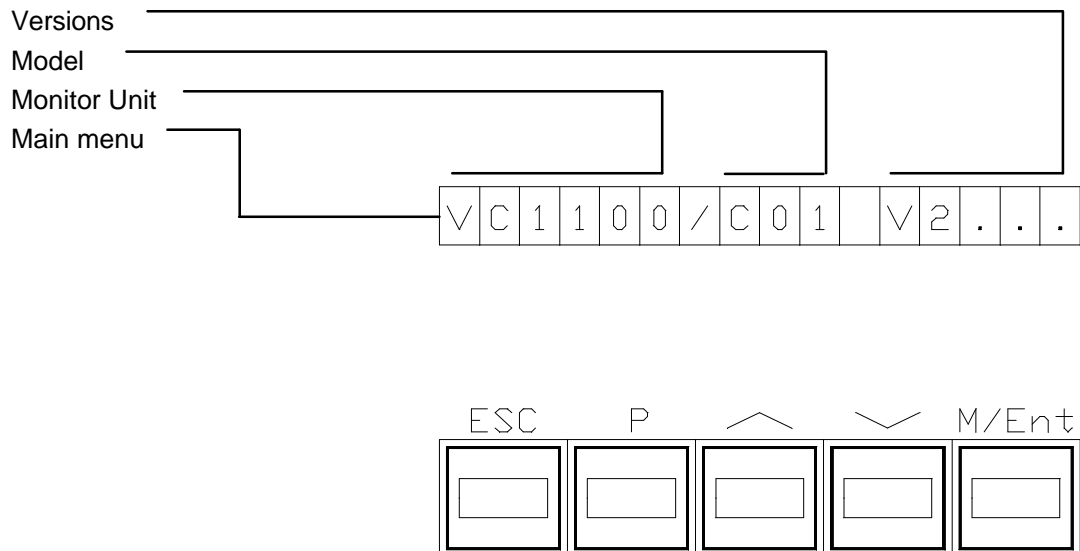

Fig. 3 - 11: Interfacing a HOST with several VC-1100's

Use commercially available shielded data transfer cables with two twisted pairs.

4 Built-in Operating Panel and Display

Open the housing to reveal the operator panel.



VC1100/BET002 (940816)

Display

A 16 digit alphanumeric LCD display provides access to the Measured Values, Relay Status, Log Book, and Setup Parameters.

During normal operation the display is dark. The display shown in the above figure appears after pressing any key. This display - the main menu - informs the user about the monitor unit, model and version.

Starting from the main menu, you can access the different function modes by pressing appropriate keys.

The microprocessor returns to the main menu automatically if a key is not pressed for 15 minutes, and the display will be turned off after an additional 15 minutes of inactivity.

Display Setup Parameters

Starting point



During normal operation the display is dark. The main menu will appear if any key is press.



Press any key.
The main menu appears.



Parameter value
Parameter number

Display Setup Parameters



Pressing this key at this time has no effect, since I01 is the first parameter.



Step to the next parameter number.
Reach any parameter by pressing either the up or down arrow key. Press and release the key to go to the next parameter (single step). Press and hold the key if you want to scroll through the parameter numbers faster. The longer you hold a key down, the faster the parameter numbers change. The last parameter is P02.

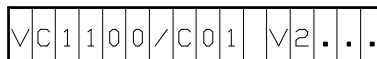

Exit "Display Setup Parameters" mode and return to the main menu.

Change Setup Parameters

Access all modes from the main menu.

Exit a mode and return to the main menu by pressing .

If the display is dark, press any key to turn it on.

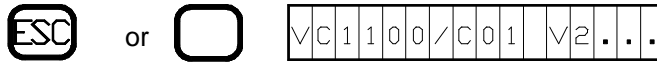

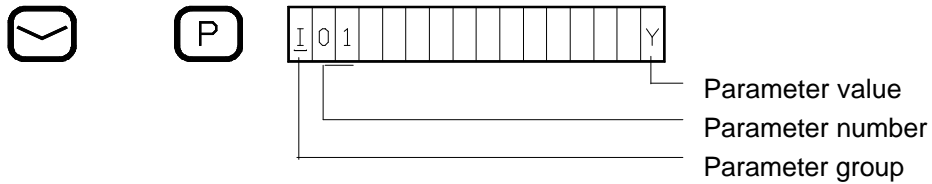

The main menu appears.



Hold the  key DOWN, then press  key.

A cursor that underlines the parameter group indicates that the parameter group and number can be changed.

Step to the next parameter number using the  and  keys.



Pressing this key at this time has no effect, since I01 is the first parameter.



Step to the next parameter number.



Reach any parameter by pressing either the up or down arrow keys. Press and release the key to go to the next parameter (single step). Press and hold the key if you want to scroll through the parameter numbers faster. The longer you hold a key down, the faster the parameter numbers change.

The last parameter is P02.

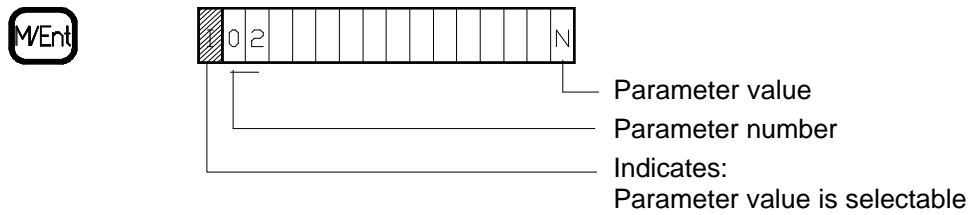

Access the change parameter value mode by pressing .



A flashing parameter group indicates change of the parameter value is allowed.

  Change the parameter value using the  and  keys.



To save the shown parameter value press  again. The parameter group no longer flashes. The new parameter value is in effect upon exiting to the main menu .

 Step to the next parameter number.

or

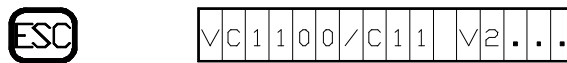

Exit "Change Setup Parameters" and return to the main menu. The microprocessor will automatically start a consistency check for the new parameter list. This check will generate an error message if the parameters are not consistent.

Example:

The following parameters I03 Vibration velocity transducer v
J05 Unit of the measured parameter g

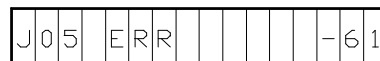

Error messages see explanations on page 16.



Confirm the error messages by pressing any key. The program will automatically show the inconsistent parameter.

Correct the error:

Press

Adjust parameter value:

Accept parameter value by pressing .

Exit to main menu .

If the setup is consistent, the program returns to the main menu. If not, the display shows the next error message. Correct this error and repeat the procedure until the setup is consistent. Find explanations of error messages on pages 15 of this chapter

Escape from the change parameter value mode by pressing .



Indicates:
Parameter value is selectable



Indicates:
Parameter numbermode is selectable

Press to return to the select parameter number mode.

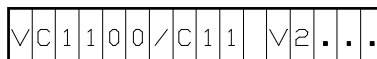

Press again to return to the main menu.

Quick Reference to the Change Setup Parameters Mode



The start is always made from the main menu.
Enter the "Change Setup Parameters" mode



Select the **parameter** you want to change.



Access the change parameter value mode



Change the **parameter value**.



Save the new parameter value.
Change other parameters or press  to return to the main menu. If the new setup is consistent, it is accepted and it becomes the current setup and the main menu appears.

If not, an error message will appear (see previous page).
The consistency check takes about 15 s. During this time the monitoring function is suspended.

Display Measured Values

Access all modes from the main menu. Exit a mode and return to the main menu by pressing . If the display is dark, press any key to turn it on.

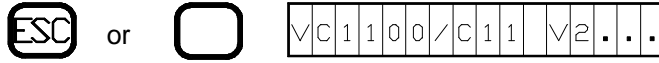

Main menu appears.

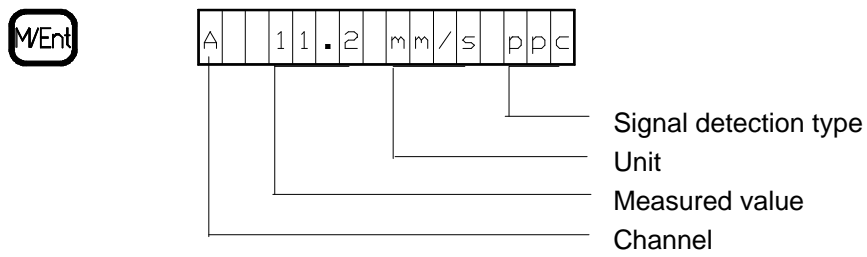

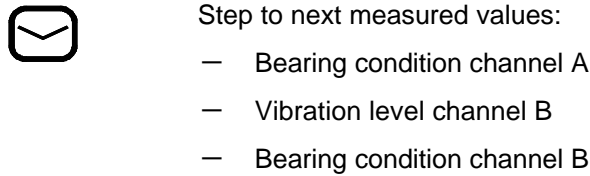

The display shows vibration level of channel A. A flashing display indicates a limit value was exceeded.



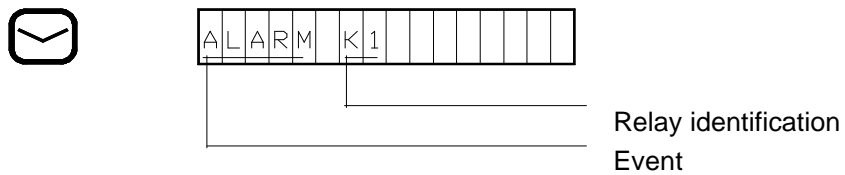

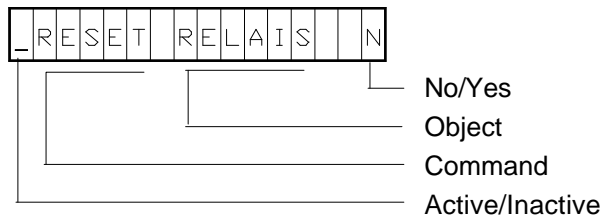
Relay status



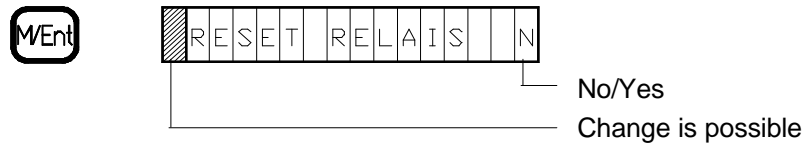

Step to next entry using  key, or press ...



Press  to enter the change status mode



Select:
 Y: Reset relays
 N: Do not reset relays.





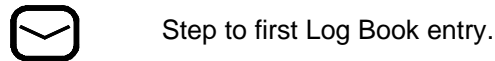
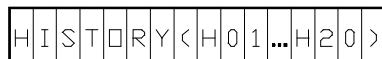
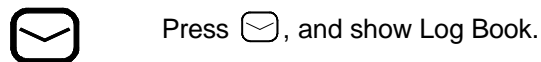

Accept reset command and return to display mode.



The Log Book stores up to 99 events.
After the last Log Book entry, you can delete the Log Book.

_	R	E	S	E	T		H	I	S	T	O	R	Y		N
---	---	---	---	---	---	--	---	---	---	---	---	---	---	--	---

Delete Log Book: Press  to allow change
Select Y using  
Press  to delete the Log Book.

The Log Book is deleted

_	R	E	S	E	T		H	I	S	T	O	R	Y		Y
---	---	---	---	---	---	--	---	---	---	---	---	---	---	--	---



Exit the Display measured values mode and return to the main menu.

Find an explanation of the Log Book entries and events on pages 14 and 15 of this chapter.

Service Mode

Access all modes from the main menu. Exit a mode and return to the main menu by pressing . If the display is dark, press any key to turn it on.





Main menu appears.

Before accessing the service mode, consider that

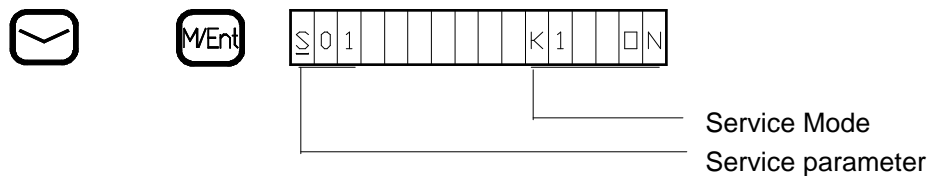
- a) the service mode suspends the measuring and monitoring modes.
- b) activating the relays could cause machine shut-down.



Hold down the  key, and press the  key to enter the service mode. The service functions all start with an S.

Check Relays

The service mode provides direct access to relay activation.



Indicates the test function is active

Change the relay status by pressing and .
Used to check operation of devices connected to the relays.

K1 off: Relay not active.
K1 on: Relay active



Press to exit test of relay K1.
Step to next function by pressing .
Check relays K2 and K3:



Function S04 checks the OK-Relay.

OK off : OK-Relay not active.
OK on : OK-Relay active.

Press to exit the OK-Relay test.



Test analog output 1.

Select voltages of 0, 2, 5, or 10 Volt by pressing

Press to exit. Press to go to next test.



Test analog output 1.

Select currents of 0, 4, 12, or 20 mA by pressing

Analog output 2 is tested in the same manner.

Analog Output 2	Voltage
<u>S07</u>	0 V
	2 V
	5 V
	10 V

Analog Output 2	Current
<u>S08</u>	0 mA
	4 mA
	12 mA
	20 mA



Press to start the self-test. During the self-test, a count down from 10 to 0 is displayed. OK will appear on the display if the test is completed successfully.

The self-test does not suspend the monitoring mode.



S	1	0		C	A	L	I	B	R	A	T	I	O	N
---	---	---	--	---	---	---	---	---	---	---	---	---	---	---

VIBROCONTROL 1100 has the ability to perform a self-calibration. This function requires about 20 minutes. During the self-calibration the monitoring mode is suspended, a count down is and displayed from ??? to 0, at which time the display returns to:

S	1	0		C	A	L	I	B	R	A	T	I	O	N
---	---	---	--	---	---	---	---	---	---	---	---	---	---	---



Press  to exit self-calibration and return to the main menu.

Events

The microprocessor stores events in the Log Book using a short notation. The Log Book can store up to 99 events. When the 100th event occurs, the "oldest event" is dropped making room for the new 100th event. The Log Book events are maintained until an instruction is received to erase all entries.

All Log Book entries start with a "H" (for History) followed by a two digit running number and a short description of the event. If a relay trips, the Log Book entry identifies the relay and the cause of the relay trip.

Example :

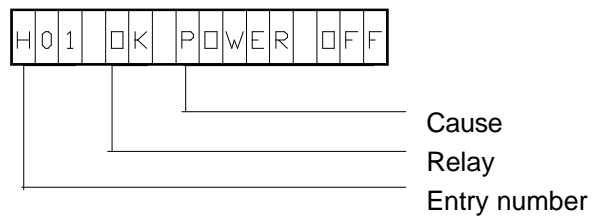

If the event is a logical AND combination of events, the combination is displayed. In this case, the plus sign replaces the AND.

A trip of the OK-Relay generates one of the following Log Book entries:



Event	Cause
OK POWER OFF	OK-Relay is active for 15 safter power is returned.
OK A	OK-Relay is active. Malfunction Channel A
OK B	OK-Relay is active. Malfunction Channel B

A trip of relays K1, K2, or K3 generates the following Log Book entries:

Event	Cause
K1 Cause	Relay K1 is active. See list of causes below.
K2 Cause	Relay K2 is active. See list of causes below.
K3 Cause	Relay K3 is active. See list of causes below.
Cause	
Lim1A	Channel A: Vibration exceeds lim_1
Lim2A	Channel A: Vibration exceeds lim_2
LimbA	Channel A: Bearing Condition exceeds lim_b
Lim1B	Channel B: Vibration exceeds lim_1
Lim2B	Channel B: Vibration exceeds lim_2
LimbB	Channel B: Bearing Condition exceeds lim_b

Relay resets generate Log Book entries:

Event	Cause
RESET DIALOG	Relay reset via built-in operator panel
RESET EXTERN	Relay reset via reset input
RESET RS-232	Relay reset via Remote-I/O

Error Messages



VIBROCONTROL 1100 automatically checks for setup consistency upon exiting the "Change Setup Parameters" mode. If the setup is not consistent, an error message is displayed.

The consistency check stops at the first inconsistency detected. It assumes that the parameter with the lowest number is correct. Therefore, a parameter other than the one displayed could be the cause of the inconsistency.

A list of error messages appears on the next page.

Unit errors

Format: ER -nn is a number with 1 to 5 digits

Example: < ER -1 <

Error code	see page 20	Meaning
-1	!	Error in operating system
-2	!	Error in operating system
-3	!	Error in operating system
-4	!	Error in operating system
-6	!	power down (last message, if time is sufficient)
-8	r	Program monitoring is out of operation or defective.
-31	r	Disrupted calibration data (run auto-calibration!)
-32	!	Error EEPROM / Hardware error
-33	!	Error ROM / Hardware error
-34	!	Error RAM / Hardware error
-35	!	Disrupted data in RAM / Hardware error
-36	k	Auto-calibration not successful / Hardware error
-37	e/r	e) No valid configuration stored in EEPROM. (Re-configure) / Hardware error r) If no valid configuration can be made, a hardware error is present.

Communication errors

Error code	see page 20	Meaning (continued)
-55	w	Correct parameter specifier received, but command cannot be processed because the requested data are not available; e.g. channel not active
-57	w	received data not accepted, because: <ul style="list-style-type: none"> a) data is not in the list of choices. b) number (INTEGER or FLOATING POINT) is out of specified range.
-58	w	Received unit of the pickup sensitivity (I04) does not correspond to the selected pickup (e.g. mV/g and vibration velocity pickup).
-59	w	The sensitivity (I05) is too large or too small.
-60	w	The selected measured parameter (J03/J04) cannot be processed with the selected pickup (I03); e.g. vibration acceleration with vibration velocity pickup.
-61	w	The unit (J05/J06) does not correspond to the measured parameter (J03/J04); e.g. vibration displacement cannot be measured in g.
-62	w	The selected measuring range (J09/J10; J13/J14) is too small or too large.

Error code	see page 20	Meaning (continued)
-63	w	The limit values are smaller than 10 % or larger than 100 % of the corresponding measuring range (M09/M10; M11/M12; M13/M14).
-65	w	An analog output has been configured to output BCU's and the pickup type velocity transducer (I03) has been selected.
-68		Parameter transfer is not possible since presently another transfer is made or the self-calibration is running. Repeat the command!

How to react to error-messages?

The 2nd column of the above list of error-messages contains the characters „**k**“ „**r**“ „**!**“ **2e**“ and „**w**“. These characters show what to do if the corresponding error message occurs.

k Repeat the command.
If VIBROCONTROL 1100 repeats this error-message after several retries, there is a severe problem and the instrument must be sent to SCHENCK for repair.

r Send VIBROCONTROL 1100 to SCHENCK for repair.

! This error activates the OK-relay temporarily, because an automatic restart is performed.

Sporadic occurrence of this error indicates that external noise affects the unit. Check installation, especially shielding of cables and grounds.

Permanent occurrence of this error indicates a severe fault. Send unit to SCHENCK for repair.

e Re-do configuration or download consistent setup. If this is not successful, send unit to SCHENCK for repair.

w Repeat command using correct data.

5 List of Setup Parameters

Basic Concepts

VIBROCONTROL 1100 stores its setup parameters in non-volatile memory. The operating system uses this data to configure the analog circuits and the software modules. All data is uniquely named. We call this data "Setup Parameters" or simply "Parameters" and reference them by name. The setup parameter values can easily be changed within predefined ranges, providing a convenient way to configure the measuring and monitoring system.

VIBROCONTROL 1100 checks the consistency of the setup after leaving the "Change Setup Parameters" mode. If the setup is inconsistent, the display shows an error messages. The setup must be corrected since the VIBROCONTROL 1100 will not accept an inconsistent setup.

Parameter list structure

Parameters are listed in sequence with a complete definition. The definition describes its function, choices, and range.

The same format is used for all parameters.

Example:

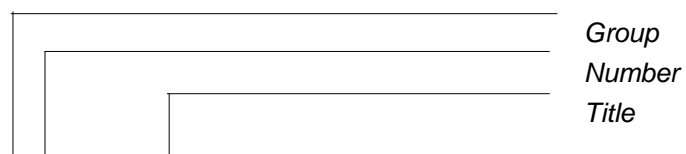

<i>K 01</i>	<i>Channel A:</i>	<i>Lower Frequency Corner</i>
--------------------	--------------------------	--------------------------------------

Choices: 1 Hz, 3 Hz, 10 Hz ISO

Function: Select the lower frequency corner for channel A

Parameter specifier

All setup parameters are organized in functional groups. The "Parameter Specifier" consists of a group and a number within the group. The first character specifies the group and the two digit number specifies the individual parameter.

Parameter Title

The "Parameter Title" is a short description of the parameter's function.

Parameter Groups













- Group I** Channel and Pickup Selection
Define measuring channels
Pickup type and sensitivity
- Group J** Channel Configuration
Define measured parameters, units, signal detection type, and full scale.
- Group K** Filter Configuration
Define upper and lower frequency corners.
- Group L** Analog Outputs
Assign measured parameters and define signal type.
- Group M** Limit Configuration
Define monitoring functions, limit values and delay times.
- Group N** Relay Configuration
Assign limit values to relays. Define relay operation.
- Group O** OK Monitoring
Enable/Disable
- Group P** Serial Interface
Define device address and baud rate.
- Group S** Service Functions
Check relay operation.
Set analog outputs to predefined levels.
Run self-test and
Self-calibration.

Additional Information

A functional description of the setup parameters for a group consists of text and usually a block diagram. The block diagram shows one channel only for simplicity.

The following is a list of the symbols that are used in the block diagrams, and their meaning.

Symbols

	Range check
	Amplifier
	Digital-to-Analog Converter
	Limit value check
	Filter, exponential
	Delay time
	Logical AND
	Logical OR
	Latch
	Logical NOR
	Setup Parameters and variables
	Error message

LEGENDE E (940923)

Fig. 5 - 1: Legend

This page has been reserved for your notes.

Channel and Pickup Selection Group I

General

Configure VIBROCONTROL 1100 as a Single- or Dual-channel monitor. Use channel A or channel B in the Single-channel mode.

In the Dual-channel mode, VIBROCONTROL 1100 only accepts pickups of the same type and sensitivity.

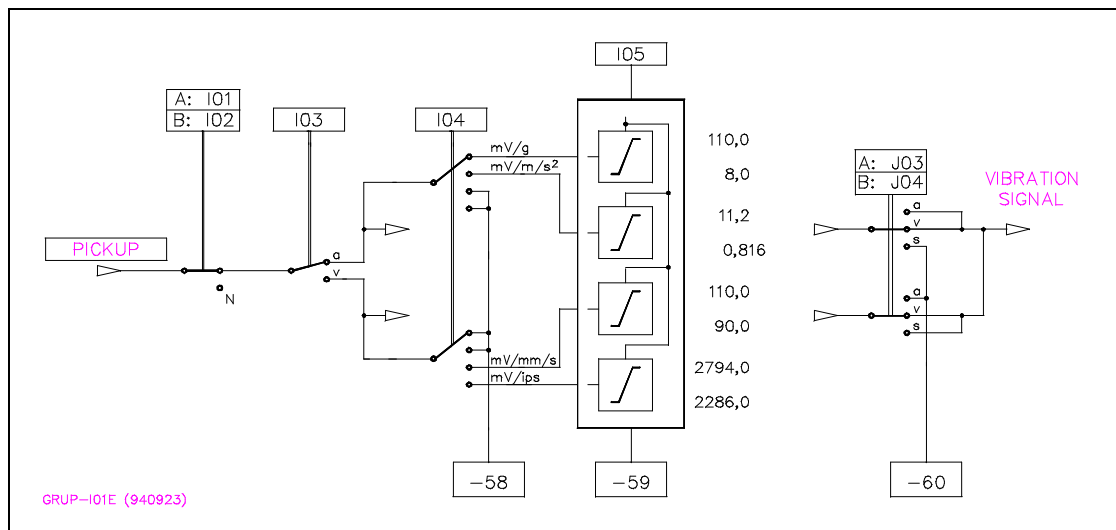

Fig. 5 - 2: Parameter Group I, Channel Selection

I 01 Channel A

Choices : Y, N

Function : Enable or disable Channel A.

Y = Yes Channel A is active

N = No Channel A is not active

I01 = Y : For measured value acquisition, connect a pickup to channel A.

I01 = N : Disables all measuring and monitoring functions for channel A.

I 02 Channel B

Choices : Y, N

Function : Enable or disable Channel B.

Y = Yes Channel B is active

N = No Channel B is not active

I02 = Y : For measured value acquisition, connect a pickup to channel B.

I02 = N : Disables all measuring and monitoring functions for channel B.

I 03 Transducers

Choices : a, v

Function : Select transducer type.

I03 = a Use accelerometers.

I03 = v Use vibration velocity transducers.

Use the same pickup type with the same sensitivity for channel A and B.

I 04 Unit

Choices : mV/g, mV/m/s², mV/ips, mV/mm/s

Function : Define unit of pickup sensitivity.

I04 defines the unit of pickup sensitivity for both channels. If the unit does not match the pickup type, VIBROCONTROL 1100 generates error-message: -58.

Select

mV/g or mV/m/s² for accelerometers

mV/mm/s or mV/ips for vibration velocity transducers.

I 05	Sensitivity
-------------	--------------------

Range : 0.8 ... 3750
 Resolution : 0.8 ... 0.999
 1.00 ... 9.99
 10.0 ... 99.9
 100 ... 3750

Function : Pickup sensitivity

I05 defines the pickup sensitivity for channel A and B.
 VIBROCONTROL 1100 accepts sensitivities within the ranges listed in the following table:

Pickup type	Unit	min. value	max. value
Accelerometer (I03 = a)	mV/g	8.0	120
	mV/m/s ²	0.8	12
Vibration Velocity (I03 = v)	mV/mm/s	15	150
	mV/ips	375	3750

I 06	Frequency response linearization
-------------	---

Choices : Y, N
 Function : Y = Yes Frequency response linearization is active
 N = No Frequency response linearization is not active

At a switch-on of the frequency response linearization, the Schenck vibration velocity pickup supplies an exact measurement even in low frequency ranges, e.g. measurements below the natural frequency of the pickup ($f_0 < 8$ Hz or $f_0 < 15$ Hz according to the pickup type).

The standard equipment of the VIBROCONTROL 1100 system comprises a frequency response linearization for transducer natural frequencies of $f_0 = 8$ Hz. The special design for $f_0 = 15$ Hz is identified by the adhesive label „moving coil linearization 15 Hz“ which is located on the right side of the printed circuit cover underneath the grounding bar, after opening the lid.

This page has been reserved for your notes.

Signal Detection Type Group J

General

Group J defines how the incoming vibration signal is processed and displayed.

The signal processing block diagram shows the function of the setup parameter and uses the following terms:

- Vibration Signal : Output of the vibration transducer.
- Measured Parameter : Vibration displacement, Vibration velocity, Vibration acceleration.
- Unit : Unit of the measured parameter. VIBROCONTROL 1100 uses the same unit for the limit values
- Signal detection type : rms, zero-to-peak calculated (pc), peak-to-peak calculated (ppc)

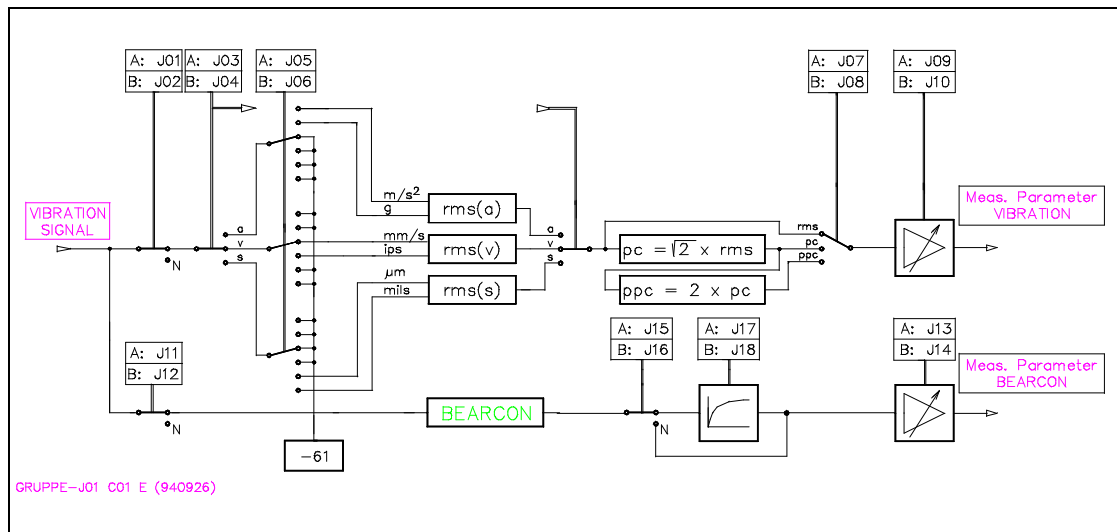

Fig. 5 - 3: Parameter Group J, Signal Detection Type

Measuring ranges

The measuring range depends on the selected pickup type, measured parameter, and signal detection type. The range is continuously adjustable within the minimum and maximum values shown in the table.

Pickup	Unit	Measuring range					
		rms		pc		ppc	
		min	max	min	max	min	max
a	m/s ²	0... 4.00	0... 800	0... 6.00	0... 999	0... 12.0	0... 999
	g	0... 0.40	0... 80.0	0... 0.60	0... 120	0... 1.20	0... 240
	mm/s	0... 5.00	0... 999	0... 7.50	0... 999	0... 15.0	0... 999
	ips	0... 0.20	0... 40.0	0... 0.30	0... 60.0	0... 0.60	0... 120
v	mm/s	0... 5.00	0... 150	0... 7.50	0... 225	0... 15.0	0... 450
	ips	0... 0.20	0... 6.00	0... 0.30	0... 9.00	0... 0.60	0... 18.0
	mm	0... 50.0	0... 333	0... 75.0	0... 500	0... 150	0... 999
	mils	0... 2.00	0... 13.3	0... 3.00	0... 20.0	0... 6.00	0... 40.0

Bearing condition (BEARCON)

a	BCU	0... 1.00	0... 140
---	-----	-----------	----------

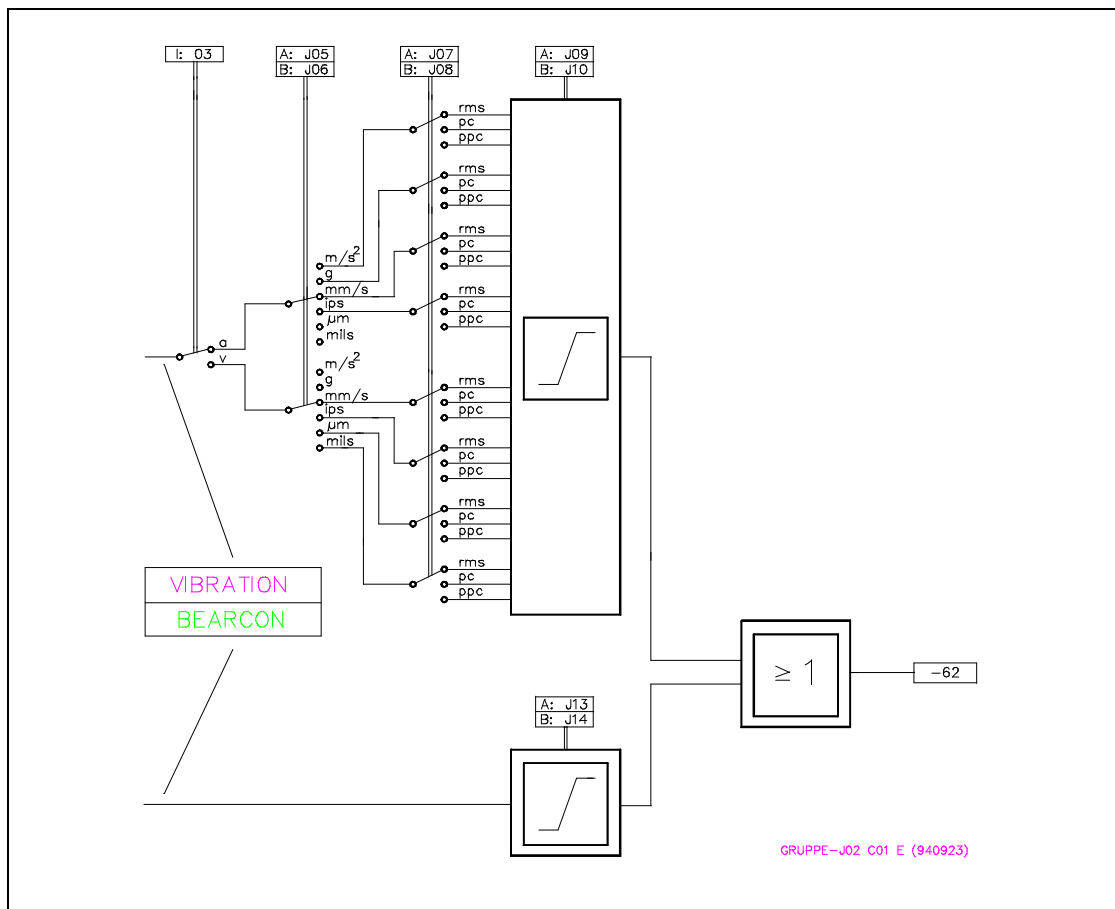

Fig. 5 - 4: Parameter Group J, Signal Detection Type

J 01 Channel A : Vibration

Choises : Y, N
Function : Enable or disable signal processing for channel A
Y = Yes Channel A processes the vibration signal
N = No Channel A does not processes the vibration signal

J 02 Channel B : Vibration

Choises : Y, N
Function : Enable or disable signal processing for channel B
Y = Yes Channel B processes the vibration signal
N = o Channel B does not processes the vibration signal

J 03 Channel A : Measured Parameter:

Choises : a, v, s
Function : Define the measured vibration parameter for channel A
a = Vibration acceleration
v = Vibration velocity
s = Vibration displacement

J 04 Channel B : Measured Parameter

Choises : a, v, s
Function : Define the measured vibration parameter for channel B
a = Vibration acceleration
v = Vibration velocity
s = Vibration displacement

J 05	Channel A : Unit
-------------	-------------------------

Choices : g, m/s², ips, mm/s, mils, μm

Select English or metric units for the measured vibration parameter of channel A.

Select g or m/s ²	for vibration acceleration
Select ips or mm/s	for vibration velocity
Select mils or μm	for vibration displacement

Unit		Measured Parameter
g	m/s ²	J03 = a
mm/s	ips	J03 = v
μm	mils	J03 = s

If the unit does not match the selected measured parameter (J03), the consistency check generates error-message -61.

J 06	Channel B : Unit
-------------	-------------------------

Choices : g, m/s², ips, mm/s, mils, μm

Select English or metric units for the measured vibration parameter of channel B.

Select g or m/s ²	for vibration acceleration
Select ips or mm/s	for vibration velocity
Select mils or μm	for vibration displacement

Unit		Measured Parameter
g	m/s ²	J04 = a
mm/s	ips	J04 = v
μm	mils	J04 = s

If the unit does not match the selected measured parameter (J04), the consistency check generates the error-message - 61.

J 07	Channel A :	Signal Selection Type
-------------	--------------------	------------------------------

Choises : rms, pc, ppc
 rms = Root-mean-square value
 pc = Zero-to-peak calculated value
 ppc = Peak-to-peak calculated value

J 08	Channel B :	Signal Selection Type
-------------	--------------------	------------------------------

Choises : rms, pc, ppc
 s = Root-mean-square value
 pc = Zero-to-peak calculated value
 ppc = Peak-to-peak calculated value

J 09	Channel A :	Full scale (Vibration)
-------------	--------------------	-------------------------------

Range	:	0.200 ... 999		
Resolution	:		0.200 ...	0.999
			1.00 ...	9.99
			10.0 ...	99.9
			100 ...	999

Function : Define full scale value for the measured vibration parameter of channel A. You can use different full scale values for channel A and B.

VIBROCONTROL 1100 uses the full scale values to automatically configure the analog circuits, display functions, monitoring functions, and the analog outputs.

If you enter full scale values outside the ranges defined in the table, the consistency check generates error message -62.

J 10	Channel B :	Full scale (Vibration)
-------------	--------------------	-------------------------------

Range	:	0 ... 999		
Resolution	:		0.200 ...	0.999
			1.00 ...	9.99
			10.0 ...	99.9
			100 ...	999

Function : Define full scale value for the measured vibration parameter of channel B. You can use different full scale values for channel A and B.
 For more information see parameter J09

J 11 Channel A : Bearing condition (BCU)

Choises : Y, N
 Function : Enable or disable processing of BCU values for channel A
 Y = Process BCU for channel A.
 N = Do not process BCU for channel A.
 Connect an accelerometer to channel A to measure BCU.

J 12 Channel B : Bearing condition (BCU)

Choises : Y, N
 Function : Enable or disable processing of BCU values for channel B.
 Y = Process BCU for channel B.
 N = Do not process BCU for channel B.
 Connect an accelerometer to channel B to measure BCU.

J 13 Channel A : BCU Full scale:

Range : 1 ... 140
 Resolution : 1,00 ... 9,99
 10,0 ... 99,9
 100 ... 140
 Function : Define full scale value for BCU on channel A.

VIBROCONTROL 1100 uses the full scale value to automatically configure the BCU Signal Conditioner, display functions, monitoring functions, and the analog outputs.
 You can use different full scale values for channel A and B. If you enter a value outside the defined range, the consistency check generates error-message: -62.

J 14 Channel B : BCU Full scale

Range : 1 ... 140
 Resolution : 1,00 ... 9,99
 10,0 ... 99,9
 100 ... 140
 Function : Define full scale value for BCU on channel B.

VIBROCONTROL 1100 uses the full scale value to automatically configure the BCU Signal Conditioner, display functions, monitoring functions, and the analog outputs.
 You can use different full scale values for channel A and B. If you enter values outside the defined range, the consistency check generates error-message: -62.

J 15 Channel A : BCU Averaging

Choises : Y, N
Function : Enable or disable BCU Averaging
 : Y = Averaging is active
 : N = Averaging is not active
Condition : Only when BCU on channel A (J11) is active.

J 16 Channel B : BCU Averaging

Choises : Y, N
Function : Enable or disable BCU Averaging
 : Y = Averaging is active
 : N = Averaging is not active
Condition : Only when BCU on channel B (J12) is active.

J 17 Channel A : BCU Averaging delay

Range : 10 ... 3600
Dimension : Seconds
Function : Define time constant for BCU averaging chan-
 : nel A.
Condition : Averaging channel A (J15) = active.

J 18 Channel B : BCU Averaging delay

Range : 10 ... 3600
Dimension : Seconds
Function : Define time constant for BCU averaging chan-
 : nel B.
Condition : Averaging channel B (J16) = active.

J 19 Channel A : BCU Scaling Factor:

Range : 0.1 ... 10.0
Dimension : Factor
Function : Setting of all BCU measuring points to the
 same initial value by means of the BCU scaling
 factor.

J 20 Channel B : BCU Scaling Factor

Range : 0.1 ... 10.0
Dimension : Factor
Function : Setting of all BCU measuring points to the
 same initial value by means of the BCU scaling
 factor.

Filter Configuration Group K

General

Filters eliminate frequency components of the vibration signal outside a specified frequency range. The lower and upper frequency corners define the frequency range or the bandwidth of the filter.

VIBROCONTROL 1100 provides several filters which are selected based on application. For each channel an upper and lower frequency corner is selected allowing each channel to use a different filter.

International standard ISO 2373 defines a filter that guarantees comparable readings (see also standards DIN/ISO 3945 and DIN 45 666). VIBROCONTROL 1100 provides this type of filter.

ISO 2372 designates the frequency corners for this filter.

The ISO-Filter has an order of 3. The other filters you can select are 2nd order Butterworth-filters. The damping at the specified frequency corner is -1 dB.

Special Filters

If an application requires special filters, please contact your SCHENCK representative.

VIBROCONTROL 1100 can extend the signal conditioner using a piggy-back PC board with the customized filter.

The parameter list references the special filter with the choice "special". If "special" is set, the supplementary filter is switched to the selected channel.

A label on the internal housing would show the specification for the special filter.

K 01	Channel A :	Lower Frequency Corner:
-------------	--------------------	--------------------------------

Choices : 1 Hz, 3 Hz, 10 Hz ISO

Function : Select lower frequency corner for channel A.

1 Hz = Lower frequency corner

3 Hz = Lower frequency corner

10 Hz ISO = Lower frequency corner

* special = Lower frequency corner

* Possible only if a supplementary filter is installed as an option.

K 02	Channel B : Lower Frequency Corner
-------------	---

Choices : 1 Hz, 3 Hz, 10 Hz ISO

Function : Select lower frequency corner for channel B
 1 Hz = Lower frequency corner
 3 Hz = Lower frequency corner
 10 Hz ISO = Lower frequency corner
 * special = Lower frequency corner

K 03	Channel A : Upper Frequency Corner:
-------------	--

Choices : 1000 Hz ISO, 10 kHz

Function : Select upper frequency corner for channel A.
 1000 Hz ISO = Upper frequency corner
 10 kHz = Upper frequency corner
 * special = Upper frequency corner

K 04	Channel B : Upper Frequency Corner
-------------	---

Choices : 1000 Hz ISO, 10 kHz

Function : Select upper frequency corner for channel B.
 1000 Hz ISO = Upper frequency corner
 10 kHz = Upper frequency corner
 * special = Upper frequency corner

* Possible only if a supplementary filter is installed as an option.

Analog Outputs Group L

General

VIBROCONTROL 1100 provides two analog outputs. Select which measured parameter is sent to analog output 1 and 2.

The full scale values selected in setup parameters J09/J10 and J13/J14 determine the analog output calibration.

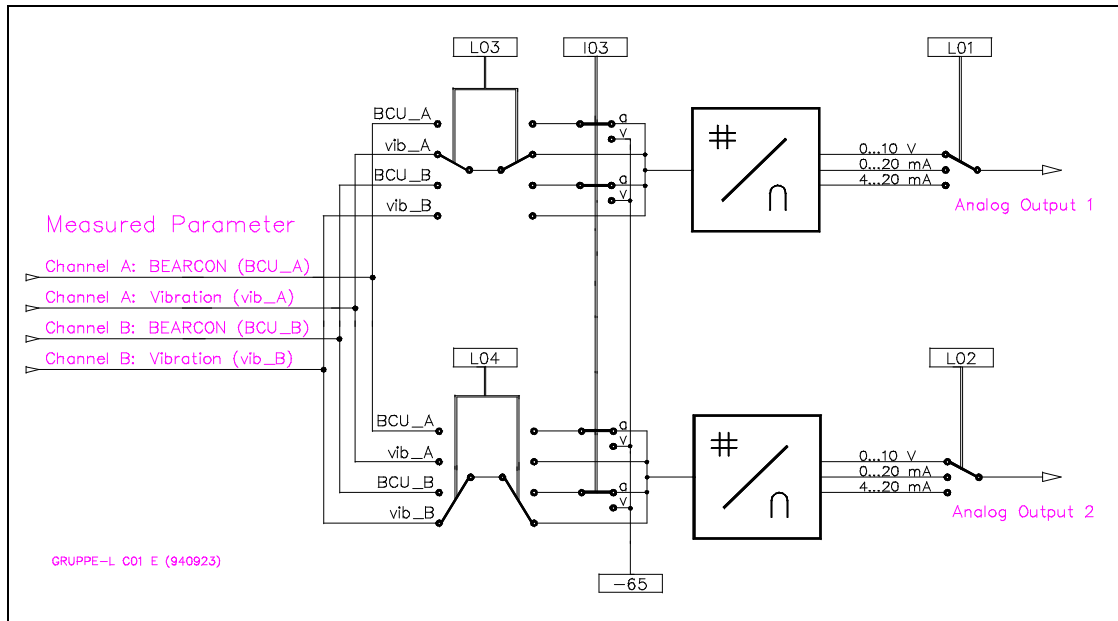

Fig. 5 - 5: Parameter Group L, Analog Outputs

You cannot select BCU values if a vibration velocity transducer is used. The consistency check will generate error message: -65.

L 01	Analog Output 1 :	Signal Range
-------------	--------------------------	---------------------

Choices : 0 ... 10 V, 0 ... 20 mA, 4 ... 20 mA
 Function : Select signal type.

L 02	Analog Output 2 :	Signal Range
-------------	--------------------------	---------------------

Choices : 0 ... 10 V, 0 ... 20 mA, 4 ... 20 mA
 Function : Select signal type.

L 03 Analog Output 1 : Measured Parameter

Choices : vib A, BCU A,vib B, BCU B
Function : Select measured parameter sent to analog output 1.
vib A = Measured Parameter:
 Vibration Channel A
BCU A = Measured Parameter:
 Bearing Condition Channel A
vib B = Measured Parameter:
 Vibration Channel B
BCU B = Measured Parameter:
 Bearing Condition Channel B

L 04 Analog Output 2 : Measured Parameter

Choices : vib A, BCU A,vib B, BCU B
Function : Select measured parameter sent to analog output 2.
vib A = Measured Parameter:
 Vibration Channel A
BCU A = Measured Parameter:
 Bearing Condition Channel A
vib B = Measured Parameter:
 Vibration Channel B
BCU B = Measured Parameter:
 Bearing Condition Channel B

L 05 Analog Output 1 : Range Full Scale

Choices : 0.000 ... 999.0
Function : In connection with an indicator or a plotter, the analog output can be scaled to an optional full scale value within the present range limits.

L 06 Analog Output 2 : Range Full Scale

Choices : 0.000 ... 999.0
Function : In connection with an indicator or a plotter, the analog output can be scaled to an optional full scale value within the present range limits.

Limit Value Configuration Group M

General

This parameter group enables or disables the monitoring functions for both channels. Three limit values can be defined for each channel; two for vibration levels and one for bearing condition. Each limit value can be enabled or disabled and its value and alarm delay time set individually.

The manual uses notations *lim_1* (limit 1), *lim_2* (limit 2), and *lim_b* (BCU) for the limit values. The unit of the corresponding measured parameter defines the unit of the limit value.

VIBROCONTROL 1100 accepts limit values in the range of 10 % to 100 % of the corresponding full scale. The consistency check generates error-message -63 if the limit values are outside this range.

Alarm delay times are in seconds. If the measured value exceeds the limit value for a time longer than the alarm delay time, VIBROCONTROL 1100 generates an event. The event is stored in the Log Book and the assigned relay is tripped as defined in the setup.

Warning:



When an OK error occurs, all limit relays maintain their current status. After removing the OK error and acknowledging it by "Relay reset", they perform their normal function again.

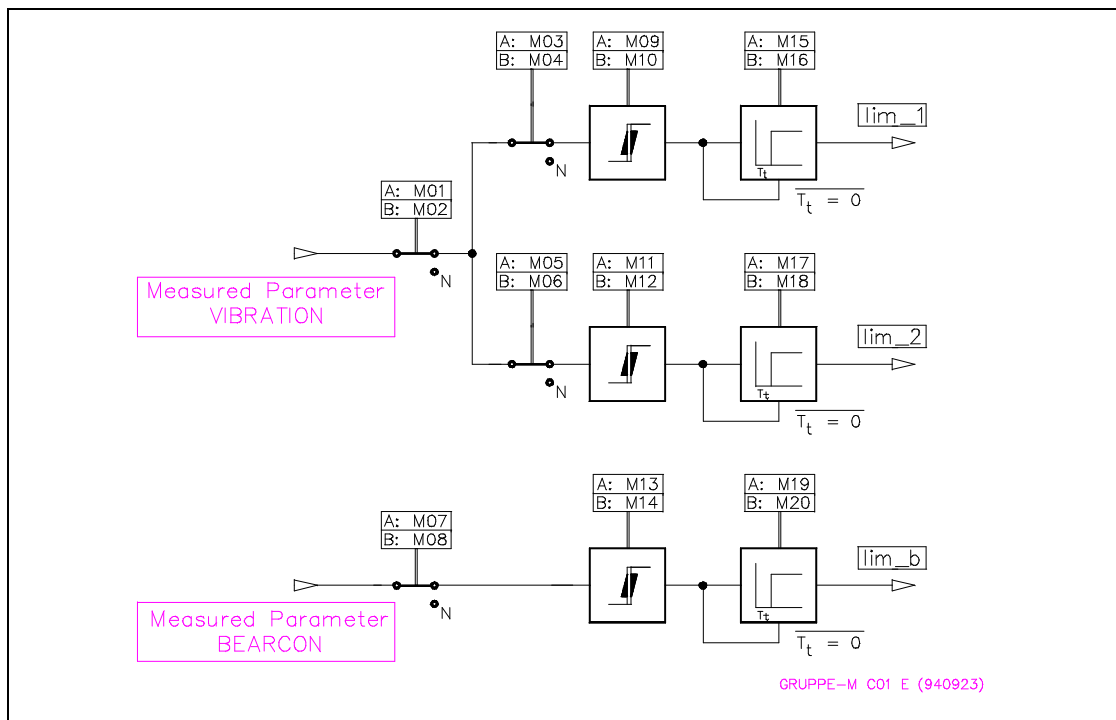

Fig. 5 - 6 : Parameter Group M, Limit Value Configuration

M 01 Channel A : Monitoring

Choises : Y, N
Function : Enable or disable vibration monitoring for channel A (lim_1, lim_2).
Y = Monitoring for channel A is active.
N = Monitoring for channel A is not active.

M 02 Channel B : Monitoring

Choises : Y, N
Function : Enable or disable vibration monitoring for channel B (lim_1, lim_2).
Y = Monitoring for channel B is active.
N = Monitoring for channel B is not active.

M 03 Channel A : Monitor lim_1

Choises : Y, N
Function : Enable or disable monitoring of limit value lim_1 A.
Y = Monitoring lim_1 A.
N = Do not monitoring lim_1 A.

M 04 Channel B : Monitor lim_1

Choises : Y, N
Function : Enable or disable monitoring of limit value lim_1 B.
Y = Monitoring lim_1 B.
N = Do not monitoring lim_1 B.

M 05 Channel A : Monitor lim_2

Choises : Y, N
Function : Enable or disable monitoring of limit value lim_2 A.
 Y = Monitoringlim_2 A.
 N = Do not monitoring lim_2 A.

M 06 Channel B : Monitor lim_2

Choises : Y, N
Function : Enable or disable monitoring of limit value lim_2 A.
 Y = Monitoringlim_2 A.
 N = Do not monitoring lim_2 A.

M 07 Channel A : Monitor lim_b

Choises : Y, N
Function : Enable or disable monitoring of limit value lim_b
 (BCU channel A).
 Y = Monitoring lim_b.
 N = Do not monitoring lim_b.

M 08 Channel B : Monitor lim_b

Choises : Y, N
Function : Enable or disable monitoring of limit value lim_b
 (BCU channel B).
 Y = Monitoring lim_b.
 N = Do not monitoring lim_b.

M 09	Channel A :	Limit value lim_1
-------------	--------------------	--------------------------

Choices : 0.020 ... 999
 Resolution : 0.020 ... 0.999
 1.00 ... 9.99
 10.0 ... 99.9
 100 ... 999
 Function : Enter limit value lim_1 A in the measured parameter units.

M 10	Channel B :	Limit value lim_1
-------------	--------------------	--------------------------

Choices : 0.020 ... 999
 Resolution : 0.020 ... 0.999
 1.00 ... 9.99
 10.0 ... 99.9
 100 ... 999
 Function : Enter limit value lim_1 B in the measured parameter units.

M 11	Channel A :	Limit value lim_2
-------------	--------------------	--------------------------

Choices : 0.020 ... 999
 Resolution : 0.020 ... 0.999
 1.00 ... 9.99
 10.0 ... 99.9
 100 ... 999
 Function : Enter limit value lim_2 A in the measured parameter units.

M 12	Channel B :	Limit value lim_2
-------------	--------------------	--------------------------

Choices : 0.020 ... 999
 Resolution : 0.020 ... 0.999
 1.00 ... 9.99
 10.0 ... 99.9
 100 ... 999
 Function : Enter limit value lim_2 B in the measured parameter units.

M 13 Channel A : Limit value lim_b

Choises : 0.100 ... 140
 Dimension : BCU
 Resolution : 0.100 ... 0.999
 1.00 ... 9.99
 10.0 ... 99.9
 100 ... 140
 Function : Enter limit value lim_b, for bearing condition
 channel A.

M 14 Channel B : Limit value lim_b

Choises : 0.100 ... 140
 Dimension : BCU
 Resolution : 0.100 ... 0.999
 1.00 ... 9.99
 10.0 ... 99.9
 100 ... 140
 Function : Enter limit value lim_b, for bearing condition
 channel B.

M 15 Channel A : Alarm Delay Time lim_1

Choises : 1 ... 99
 Dimension : Seconds
 Function : Define alarm delay time for channel A lim_1.

M 16 Channel B : Alarm Delay Time lim_1

Choises : 1 ... 99
 Dimension : Seconds
 Function : Define alarm delay time for channel B lim_1.

M 17 Channel A : Alarm Delay Time lim_2

Choises : 1 ... 99
Dimension : Seconds
Function : Define alarm delay time for channel A lim_2.

M 18 Channel B : Alarm Delay Time lim_2

Choises : 1 ... 99
Dimension : Seconds
Function : Define alarm delay time for channel B lim_2.

M 19 Channel A : Alarm Delay Time lim_b

Choises : 3 ... 99
Dimension : Seconds
Function : Define alarm delay time for channel A lim_b.

M 20 Channel B : Alarm Delay Time lim_b

Choises : 3 ... 99
Dimension : Seconds
Function : Define alarm delay time for channel B lim_b.

Relay Configuration Group N

General

VIBROCONTROL 1100 provides three relays to indicate alarm level exceedances. The relays are designated as K1, K2 and K3. Relay operation can be defined as follows:

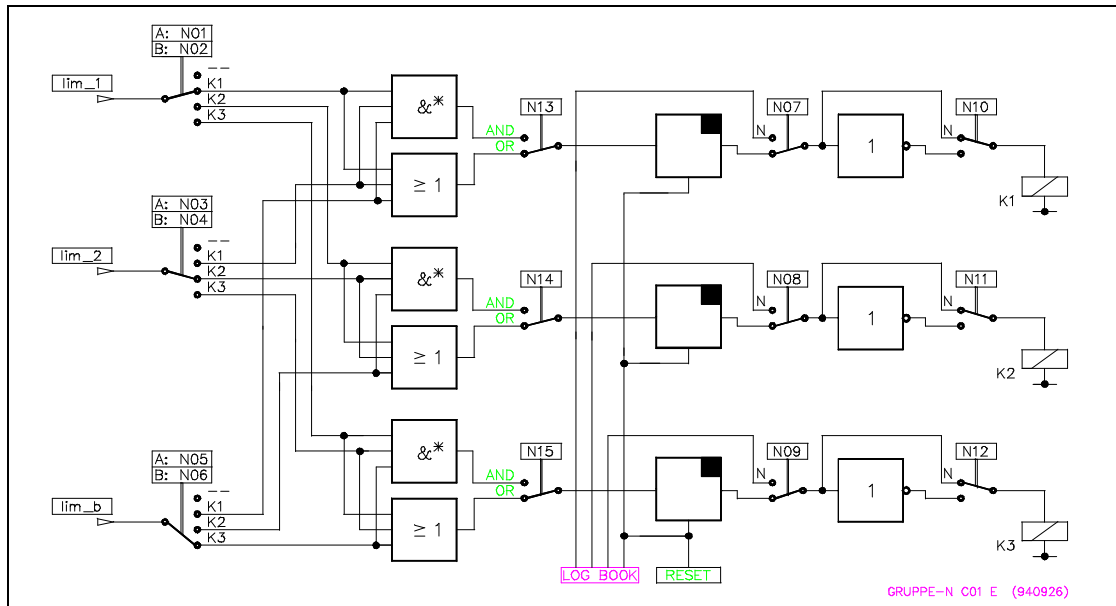

Fig. 5 - 7 : Parameter Group N, Relais Configuration

Programmable Relay Operation:

1. Which alarm level exceedance controls which relay?
2. Latching or non-latching operation?
3. Normally energized or normally de-energized operation?
4. Logical combinations.

Comments to item 1:

It is common to assign alarm levels lim_1 of channel A and B to relay K1 and alarm levels lim_2 of channel A and B to relay K2.

Comments to item 2:

In the latching mode, a relay remains latched until VIBROCONTROL 1100 receives a reset command. In the non-latching mode, VIBROCONTROL 1100 resets the relays automatically when the monitored signal drops below the limit value.

Comments to item 3:

The following table shows the contact positions for normally de-energized and normally energized relay operating modes.

Mode	No alarm	Alarm
Normally de-energized	Relay active	Relay not active
Normally energized	Relay not active	Relay active

Comments to item 4:

If several alarm limits control one relay, combine the alarms using a logical AND or a logical OR.

N 01 Channel A : lim_1 controls relay ...

Choises : --, K1, K2, K3
 Function : Assign event "lim_1A exceeded" to a relay
 -- = lim_1A does not control a relay
 K1 = lim_1A controls relay K1
 K2 = lim_1A controls relay K2
 K3 = lim_1A controls relay K3

N 02 Channel B : lim_1 controls relay ...

Choises : --, K1, K2, K3
 Function : Assign event "lim_1B exceeded" to a relay
 -- = lim_1B does not control a relay
 K1 = lim_1B controls relay K1
 K2 = lim_1B controls relay K2
 K3 = lim_1B controls relay K3

N 03	Channel A : lim_2 controls relay ...
-------------	---

Choises : --, K1, K2, K3
 Function : Assign event "lim_2A exceeded" to a relay
 -- = lim_2A does not control a relay
 K1 = lim_2A controls relay K1
 K2 = lim_2A controls relay K2
 K3 = lim_2A controls relay K3

N 04	Channel B : lim_2 controls relay ...
-------------	---

Choises : --, K1, K2, K3
 Function : Assign event "lim_2B exceeded" to a relay
 -- = lim_2B does not control a relay
 K1 = lim_2B controls relay K1
 K2 = lim_2B controls relay K2
 K3 = lim_2B controls relay K3

N 05	Channel A : lim_b controls relay ...
-------------	---

Choises : --, K1, K2, K3
 Function : Assign event "lim_bA exceeded" to a relay
 -- = lim_bA does not control a relay
 K1 = lim_bA controls relay K1
 K2 = lim_bA controls relay K2
 K3 = lim_bA controls relay K3

N 06	Channel B : lim_b controls relay ...
-------------	---

Choises : --, K1, K2, K3
 Function : Assign event "lim_bB exceeded" to a relay
 -- = lim_bB does not control a relay
 K1 = lim_bB controls relay K1
 K2 = lim_bB controls relay K2
 K3 = lim_bB controls relay K3

N 07 Relais K1 : Latching

Choises : Y, N

Function : Select latching or non-latching operation for relay K1.

Y = Relay K1 latches.

N = Relay K1 does not latch.

N 08 Relais K2 : Latching

Choises : Y, N

Function : Select latching or non-latching operation for relay K2.

Y = Relay K2 latches.

N = Relay K2 does not latch.

N 09 Relais K3 : Latching

Choises : Y, N

Function : Select latching or non-latching operation for relay K3.

Y = Relay K3 latches.

N = Relay K3 does not latch.

N 10 Relais K1 : Normally Energized

Choises : Y, N

Function : Select normally energized or normally de-energized mode for relay K1

Y = Relay K1 operates normally energized.

N = Relay K1 operates normally de-energized.

N 11	Relais K2 :	Normally Energized
-------------	--------------------	---------------------------

Choises : Y, N
 Function : Select normally energized or normally de-energized mode for relay K2.
 Y = Relay K2 operates normally energized.
 N = Relay K2 operates normally de-energized.

N 12	Relais K3 :	Normally Energized
-------------	--------------------	---------------------------

Choises : Y, N
 Function : Select normally energized or normally de-energized mode for relay K3.
 Y = Relay K3 operates normally energized.
 N = Relay K3 operates normally de-energized.

N 13	Relais K1 :	Grenzwert-Verknüpfungen
-------------	--------------------	--------------------------------

Choises : OR, AND
 Function : Define how several alarm level exceedances control relay K1
 OR = Exceedance of at least one of the assigned alarm levels trips relay K1.
 AND = Only exceedance of all assigned alarm levels trips relay K1.

N 14	Relais K2 :	Logic
-------------	--------------------	--------------

Choises : OR, AND
 Function : Define how several alarm level exceedances control relay K2.
 OR = Exceedance of at least one of the assigned alarm levels trips relay K2.
 AND = Only exceedance of all assigned alarm levels trips relay K2.

N 15	Relais K3 :	Logic
-------------	--------------------	--------------

Choises : OR, AND
 Function : Define how several alarm level exceedances control relay K3.
 OR = Exceedance of at least one of the assigned alarm levels trips relay K3.
 AND = Only exceedance of all assigned alarm levels trips relay K3.

This page has been reserved for your notes.

OK-Monitoring Group O

General

VIBROCONTROL 1100 has a cyclic self-monitoring routine. This routine tests the pickups and the cables between VIBROCONTROL 1100 and the pickups. The pickup signal is checked to verify that it remains within a predefined range. This method detects errors such as disconnected pickups, broken cables and shorts. If an OK error occurs, the OK relay is tripped and the event is stored in the Log Book.

Note:

When vibration velocity transducers with moving coil are used, lead breakage or short-circuit cannot usually be recognized. A constant current is thus superposed to the measuring signal. This current effects a direct voltage drop of approx. 1 V in the VC-1100. This voltage drop is measured as OK voltage.

The OK relay is configured to the normally energized mode. In this mode a power failure at the VIBROCONTROL 1100 will trip the OK relay to the alarm position.

In special cases, for example if line drivers or isolation amplifiers are used, it might be necessary to disable the OK monitoring function for the pickups. Therefore, VIBROCONTROL 1100 provides for disabling this function. This has no effect on other self-monitoring functions.

O 01	Channel A : OK Monitoring
-------------	----------------------------------

Choices : Y, N

Function : Enable or disable OK monitoring of the pickup on channel A.

Y = OK monitoring for pickup channel A is active

N = OK monitoring for pickup channel A is not active

O 02	Channel B : OK Monitoring
-------------	----------------------------------

Choices : Y, N

Function : Enable or disable OK monitoring of the pickup on channel B.

Y = OK monitoring for pickup channel B is active

N = OK monitoring for pickup channel B is not active

O 03 Channel A : OK-Lower Limit

Choises : -23 V ... + 23 V
Function : The OK-limits are only settable for acceleration pickups.

O 04 Channel B : OK- Lower Limit

Choises : -23 V ... + 23 V
Function : The OK-limits are only settable for acceleration pickups.

O 05 Channel A : OK-Upper Limit

Choises : -23 V ... + 23 V
Function : The OK-limits are only settable for acceleration pickups.

O 06 Channel B : OK- Upper Limit

Choises : -23 V ... + 23 V
Function : The OK-limits are only settable for acceleration pickups.

Note for the definition of the OK-limits

If the input value of the OK-upper value is smaller than the input value for the OK-lower value, an OK error message is displayed.

The typical setting values for the OK-upper limit and the OK-lower limit are dependent on the transducer type. For SCHENCK transducers the following settings are recommended:

Velocity transducer (series VS - ...)

OK-upper limit : 2.5
OK-lower limit : 0.5

Acceleration sensor (series AS - ...)

OK-upper limit : - 1
OK-lower limit : -20

Serial Interface Group P

P 00	Remote I/O	:	Device Address
-------------	-------------------	----------	-----------------------

Choices : 1 ... 205
 Function : Define a unique address for each VIBROCONTROL 1100

P 01	Serial Port 1	:	Baud rate
-------------	----------------------	----------	------------------

Choices : 1200, 2400, 4800, 9600
 Unit : Bit/s
 Function : 1200 = Baud rate: 1200 Bd
 2400 = Baud rate: 2400 Bd
 4800 = Baud rate: 4800 Bd
 9600 = Baud rate: 9600 Bd

P 02	Serial Port 2	:	Baud rate
-------------	----------------------	----------	------------------

Choices : 1200, 2400, 4800, 9600
 Unit : Bit/s
 Function : Select baud rate for serial port 1.
 1200 = Baud rate: 1200 Bd
 2400 = Baud rate: 2400 Bd
 4800 = Baud rate: 4800 Bd
 9600 = Baud rate: 9600 Bd

This page has been reserved for your notes.

Service Functions Gruppe S

General

VIBROCONTROL 1100 provides direct access to the relays and analog outputs. Use these functions to test the connected peripherals including wiring.

These functions also help programmers of process control systems to verify the interface with VIBROCONTROL 1100. Additionally, VIBROCONTROL 1100 itself can be tested using the self-test and self-calibration functions.

Warning

The service functions suspend all measuring and monitoring functions.

Changing relay outputs could cause machine shutdown !

Relay Test

Switch each relay to the "active" and "inactive" position . Test the reaction of the system in both positions. Repeat the procedure for all relays including the OK- relay.

Analog Output Test

Set each analog output to a predefined output voltage or current. Check to see if the same levels are displayed, for example on the analog meter in the control room.

Self-test

The self-test takes about 15 seconds. During this test the most important modules of the microprocessor system are checked, including stored data. "Test" is displayed during the test along with a countdown from 10 to 0. The self-test is not interruptible.

Normally, "TEST ok" is displayed at the end of the self-test. Press any key to continue.

If the self-test detects an error, the error message is displayed for x seconds and automatically restarts the system.

The error message is stored in the Log Book.

Self-calibration

The self-calibration program takes about 15 minutes. During this time, the signal conditioners, multiplexers, and analog-to-digital converters, etc. are checked using an internally generated test signal.

This program does not have access to the input and output modules like relays, pre-amplifiers, and amplifiers for the analog outputs. Use the relay and analog output tests to check these functions.

"Calibration" is displayed during the self-calibration along with a number indicating the current test. This program is not interruptible. Remember that during self-calibration all measuring and monitoring functions are suspended.

The status of the relays and analog outputs does not change during the self-calibration.

S 01	Relay K1 :	Test
-------------	-------------------	-------------

Choises : K1 on, K1 off
Funktion : Test relay K1.
K1 on = Relay K1 is active
K1 off = Relay K1 is not active.

S 02	Relay K2 :	Test
-------------	-------------------	-------------

Choises : K2 on, K2 off
Funktion : Test relay K2.
K2 on = Relay K2 is active
K2 off = Relay K2 is not active abgefallen.

S 03	Relay K3 :	Test
-------------	-------------------	-------------

Choises : K3 on, K3 off
Funktion : Test relay K3.
K3 on = Relay K3 is active
K2 off = Relay K3 is not active abgefallen.

S 04	OK-Relay :	Test
-------------	-------------------	-------------

Choises : OK on, OK off
Funktion : Test OK-relay.
OK on = OK-Relay is active
OK off = OK-Relay is not active

S 05 Analog-Output 1 : Output voltage

Choises : 0 V, 2 V, 5 V, 10 V

Funktion : Set the output voltage level on analog output 1.

0 V = The output voltage is 0 Volt

2 V = The output voltage is 2 Volt

5 V = The output voltage is 5 Volt

10 V = The output voltage is 10 Volt

S 06 Analog-Output 1 : Output current

Choises : 0 mA, 4 mA, 12 mA, 20 mA

Funktion : Set the output current level on analog output 1.

0 mA = The output current is 0 mA

4 mA = The output current is 4 mA

12 mA = The output current is 12 mA

20 mA = The output current is 20 mA

S 07 Analog-Output 2 : Output voltage

Choises : 0 V, 2 V, 5 V, 10 V

Funktion : Set the output voltage level on analog output 2.

0 V = The output voltage is 0 Volt

2 V = The output voltage is 2 Volt

5 V = The output voltage is 5 Volt

10 V = The output voltage is 10 Volt

S 08 Analog- Output 2 : Output current

Choises : 0 mA, 4 mA, 12 mA, 20 mA

Funktion : Set the output current level on analog output 2.

0 mA = The output current is 0 mA

4 mA = The output current is 4 mA

12 mA = The output current is 12 mA

20 mA = The output current is 20 mA

S 09 TEST

Function : Start self-test of VIBROCONTROL 1100.

S 10 CALIBRATION

Function : Start self-calibration of VIBROCONTROL 1100.

Parameter Configuration

Plant : _____

Version : __VC 1100/C __V _____

Name : _____ Date: _____

Channel and Pickup Selection - Group I

I01	Channel A	Y []	N []		
I02	Channel B	Y []	N []		
I03	Pickup	a []	v []		
I04	Unit	mV/g []	mV/m/s2 []	mV/mm/s []	mV/ips []
I05	Sensitivity	[_____]			
I06	Frequency response linearization	Y []	N []		

Channel Configuration - Group J

J01	Channel A: Vibration	Y []	N []		
J02	Channel B: Vibration	Y []	N []		
J03	Channel A: Parameter	a []	v []	s []	
J04	Channel B: Parameter	a []	v []	s []	
J05	Channel A: Unit	g []	m/s2 []	mm/s []	
		ips []	mm []	mils []	
J06	Channel B: Unit	g []	m/s2 []	mm/s []	
		ips []	mm []	mils []	
J07	Channel A: Signal Detection	rms []	pc []	ppc []	
J08	Channel B: Signal Detection	rms []	pc []	ppc []	
J09	Channel A: Full Scale	[_____]			
J10	Channel B: Full Scale	[_____]			
J11	Channel A: Bearing Condition (BCU)	Y []	N []		
J12	Channel B: Bearing Condition (BCU)	Y []	N []		
J13	Channel A: BCU Full Scale	[_____]			
J14	Channel B: BCU Full Scale	[_____]			
J15	Channel A: BCU Averaging (BCU)	Y []	N []		
J16	Channel B: BCU Averaging (BCU)	Y []	N []		
J17	Channel A: Mean time (BCU)	[_____]			
J18	Channel B: Mean time (BCU)	[_____]			
J19	Channel A: BCU Scaling Factor	[_____]			
J20	Channel B: BCU Scaling Factor	[_____]			

Filter Configuration - Group K

K01	Channel A: Low cutoff frequency	1Hz []	3Hz []	10Hz ISO []	* Spec. []
K02	Channel B: Low cutoff frequency	1Hz []	3Hz []	10Hz ISO []	* Spec. []
K03	Channel A: High cutoff frequency	10kHz []	1kHz ISO []	* Spec. []	
K04	Channel B: High cutoff frequency	10kHz []	1kHz ISO []	* Spec. []	

Analog Output - Group L

L01	Analog Output 1:	0..10V []	0..20mA []	4..20mA []	
L02	Analog Output 2:	0..10V []	0..20mA []	4..20mA []	
L03	Analog Output 1: Parameter	vib_A []	BCU_A []	vib_B []	BCU_B []
L04	Analog Output 2: Parameter	vib_A []	BCU_A []	vib_B []	BCU_B []
L05	Analog Output 1: Full Scale	[_____]			
L06	Analog Output 2: Full Scale	[_____]			

* Possible only if a supplementary filter is installed as an option.

Limit Configuration - Group M

M01	Channel A: Monitoring	Y []	N []
M02	Channel B: Monitoring	Y []	N []
M03	Channel A: Monitor lim_1	Y []	N []
M04	Channel B: Monitor lim_1	Y []	N []
M05	Channel A: Monitor lim_2	Y []	N []
M06	Channel B: Monitor lim_2	Y []	N []
M07	Channel A: Monitor lim_b	Y []	N []
M08	Channel B: Monitor lim_b	Y []	N []
M09	Channel A: Value lim_1	[_____]	
M10	Channel B: Value lim_1	[_____]	
M11	Channel A: Value lim_2	[_____]	
M12	Channel B: Value lim_2	[_____]	
M13	Channel A: Value lim_b	[_____]	
M14	Channel B: Value lim_b	[_____]	
M15	Channel A: Delay Time lim_1	[_____]	
M16	Channel B: Delay Time lim_1	[_____]	
M17	Channel A: Delay Time lim_2	[_____]	
M18	Channel B: Delay Time lim_2	[_____]	
M19	Channel A: Delay Time lim_b	[_____]	
M20	Channel B: Delay Time lim_b	[_____]	

Relay Configuration - Group N

N01	Channel A: lim_1 assigned to	-- []	K1 []	K2 []	K3 []
N02	Channel B: lim_1 assigned to	-- []	K1 []	K2 []	K3 []
N03	Channel A: lim_2 assigned to	-- []	K1 []	K2 []	K3 []
N04	Channel B: lim_2 assigned to	-- []	K1 []	K2 []	K3 []
N05	Channel A: lim_b assigned to	-- []	K1 []	K2 []	K3 []
N06	Channel B: lim_b assigned to	-- []	K1 []	K2 []	K3 []
N07	Relay K1: Latching	Y []	N []		
N08	Relay K2: Latching	Y []	N []		
N09	Relay K3: Latching	Y []	N []		
N10	Relay K1: Normally Energized	Y []	N []		
N11	Relay K2: Normally Energized	Y []	N []		
N12	Relay K3: Normally Energized	Y []	N []		
N13	Relay K1: Logic	AND []	OR []		
N14	Relay K2: Logic	AND []	OR []		
N15	Relay K3: Logic	AND []	OR []		

OK Monitoring - Group O

O01	Channel A: OK-Monitoring	Y []	N []
O02	Channel B: OK-Monitoring	Y []	N []
O03	Channel A: OK-Lower Limit	[_____]	
O04	Channel B: OK-Lower Limit	[_____]	
O05	Channel A: OK-Upper Limit	[_____]	
O06	Channel B: OK-Upper Limit	[_____]	

Baud Rate for Serial Interface - Group P

P00	Device Address	[_____]			
P01	Serial Port 1:	9600 []	4800 []	2400 []	1200 []
P02	Serial Port 2:	9600 []	4800 []	2400 []	1200 []

6 Installation and Commissioning

Installation



VIBROCONTROL 1100

Vibration transducers:

Wiring:

Grounding:

Mount rear side down

Consult transducer manual

Consult chapter 3 of this manual

Consult grounding recommendations

See chapters 2 and 3 of this manual for technical data and details on serial interfacing. Seal unused cable ports using ... AC-xxx.

Commissioning

CAUTION !

The safety instructions are attached as a separate brochure in different languages.

Check wiring

Check supply voltage

Power Monitor

Enter setup parameters required for this installation

Connect transducers

Once the transducers are connected and power is applied, the OK error must clear showing everything is configured correctly.



Connect peripheral devices to relays and analog outputs.
Connect serial interfaces as required

Checks

Use the VIBROCONTROL 1100 service functions to verify all connected peripheral functions.

Service functions are described in chapter 5, under setup parameters group S.

Relays: Service parameters S01...S04

Analog outputs: Service parameters S05...S08

These functions provide a means to switch each relay separately and to set the analog outputs to predefined values.

Complete the installation by running self-test (S09) and auto-calibration (S10).

Recommendation

Run auto-calibration under operating conditions with the machinery running.

The auto-calibration function does not change setup parameters.