

# LCSF Low Clearance Split Frame

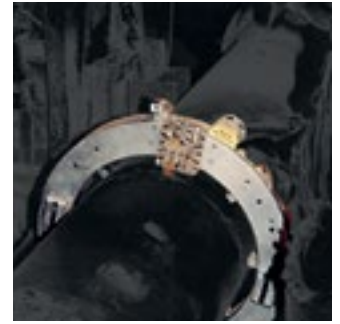

Designed For Portability And Limited Clearance

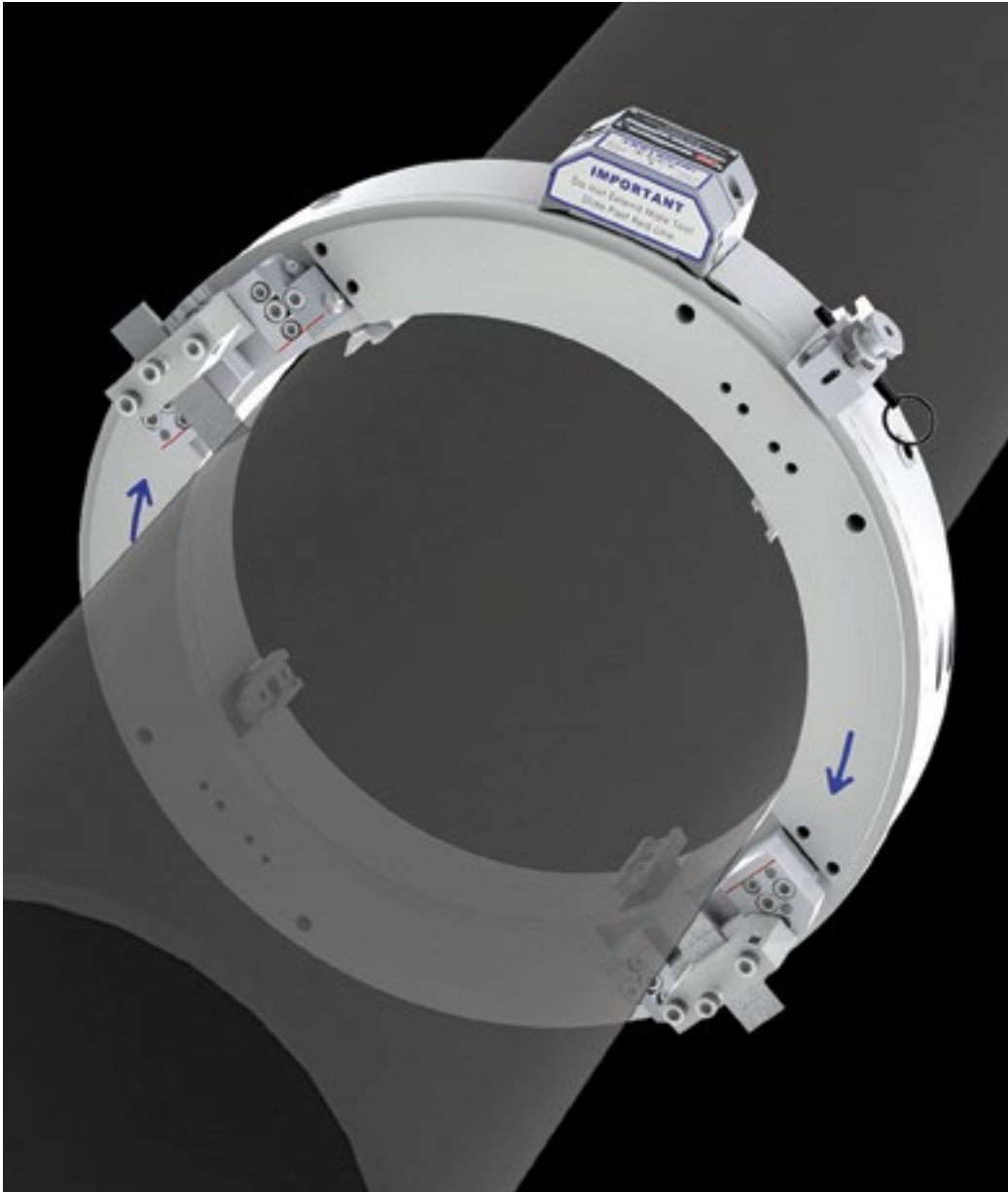

Full Range 2in - 48in for Pipe and Tube



Optional Bridge Slide for Heavy Wall Pipe

## EXTERNALLY MOUNTED PORTABLE PIPE CUTTING AND BEVELING SYSTEM

E.H. Wachs LCSF Low Clearance Split Frame is the world's most versatile and comprehensive line of lightweight split frame, clamshell style portable machine tools on the market today. Designed to cut, bevel, single point, counterbore and face flanges on pipe and tube ranging from 2in - 48in (DN50 - DN1200) OD (Outside Diameter) on most wall thicknesses and materials, Wachs slim yet rugged LCSF design is ideal where radial and axial clearances are restricted.



# LCSF Low Clearance Split Frame



Hot torch cut before machining



Weld ready after machining



Heavy duty storage case

## PORTABLE PIPE CUTTING AND BEVELING MACHINES

- Twelve LCSF basic models cover OD from 2" - 48" (DN 50 to DN 1200)
- Low clearance design requires minimal space for setup and operation
- Designed to split open to mount around the OD of inline pipe
- Fully enclosed bearings and drive gears for safety and durability
- Tool slides and accessories are interchangeable between many LCSF sizes

### COLD CUTTING

The LCSF is ideal for all types of pipe cutting, beveling and end prepping.

The Split Frames are named for their ability to split in half at the frame or "break open" and bolt back together again. This allows them to open and mount around the OD of inline piping or they can be slipped closed over open ended pipe. The LCSF has been engineered to apply precise, consistently square cuts and bevels on pipe, tube and casing the first time, every time.

Like all WACHS cutting machines, the LCSF Split Frame utilizes a cold cutting machining process, a safe, clean operation that minimizes the risk of explosion. Hot torch cutting and grinding typically creates a heat affected zone (HAZ) and introduces airborne contaminants into the environment, unacceptable in many worksites and a potential health hazard.

### COMPLETE MACHINING SYSTEM

The LCSF is the foundation of a complete machining system, a system that includes multiple drive options, hydraulic power units, bridge slides, counterbore attachments and a wide range of tooling and tool slides. These include low clearance slides, extended and super extended slides, worm gear slides for heavy wall applications and out-of-round tracking slides that minimize setup and machining time. The LCSF is able to handle virtually any cutting and beveling application encountered in the field, including tight clearances, heavy wall pipe or high alloy material. WACHS allows you to take on the most challenging prep with confidence, as the correct power source, drive, tool slides and tooling are never more than a phone call away.

E.H. WACHS LCSF machines are offered as complete kits, with your choice of pneumatic, hydraulic or, by special order electric drive, or as basic ring sets. Kits are the more popular choice, as they include the components typically required including drive, tool slides, trips, hand tools and more. But if you already own WACHS drive motors and tool slides, individual ring sets can economically expand your split frame range.

Ideal for a wide range of industries, the LCSF is found in fossil, co-gen and nuclear power plants for outages, steam generator replacements and general plant maintenance. They're used in oil, gas and petrochemical to minimize the risk of explosion and anywhere that safe, high quality, repeatable weld preps are required. It's the most complete pipe cutting and beveling machining system available today.

Like all WACHS machines, the LCSF is built to last. Steel gear sets, fully enclosed for safety and durability, ride on full roller bearings to handle the rigors of today's demanding preps on today's demanding materials. Strong yet light, the LCSF machines with a speed and precision others can't match.

# LCSF Low Clearance Split Frame

**IMPORTANT:** Product training is recommended for safe operation of the LCSF split frame.

Please contact your E.H. Wachs representative for details.

Specifications		206/3	408/3	612/3	814/3	1016/3	1420/3	1824/3	2228/3	2632/3	3036/3	3642/3	4248/3
<b>Machine capacity</b>													
Pipe OD Metric	mm	60.3-168.4	114.3-219.2	168.3-323.85	219.1-355	273.1-406.4	355.6-508	457-610	558-711	660-813	762-914	914-1067	1067-1219
Pipe NPS	inch	2-6	4-8	6-12	8-14	10-16	14-20	18-24	22-28	26-32	30-36	36-42	42-48
<b>Dimensions</b>													
A dimension	mm	174.75	225.55	330.20	361.95	412.75	514.35	622.30	723.90	825.5	927.1	1079.50	1231.90
	inch	6.88	8.88	13.0	14.25	16.25	20.25	24.50	28.50	32.50	36.50	42.50	48.50
<b>Extended tool slide tool stroke 1.5" (38.1 mm) using slide 960 415 000 or 960 416 000</b>													
B dimension	mm	163.83	216.15	277.88	290.83	322.58	373.38	422.40	473.20	524.00	574.80	651.3	727.5
	inch	6.45	8.51	10.94	11.45	12.70	14.70	16.63	18.63	20.63	22.63	25.64	28.64
C dimension	mm	152.40	152.40	152.40	152.40	152.40	152.40	177.80	177.80	177.80	177.80	177.8	177.8
	inch	6.00	6.00	6.00	6.00	6.00	6.00	7.00	7.00	7.00	7.00	7.00	7.00
<b>Super extended tool slide tool stroke 2" (50.8 mm) using slide 960 437 000 or 960 438 000</b>													
B dimension	mm	-	-	-	-	-	-	482.60	533.40	584.20	635.00	711.20	787.40
	inch	-	-	-	-	-	-	19.00	21.00	23.00	25.00	28.00	31.00
C dimension	mm	-	-	-	-	-	-	177.80	177.80	177.80	177.80	177.80	177.80
	inch	-	-	-	-	-	-	7.00	7.00	7.00	7.00	7.00	7.00
<b>Weights</b>													
Machine	kg	16.78	19.50	28.57	33.11	39.91	46.72	79.38	90.72	104.32	117.93	140.60	163.29
	lbs	37	43	63	73	88	103	175	200	230	260	310	360
Shipping	kg	43.5	43.5	57	64	75	87.5	226	235	244	239.5	271	304
	lbs	96	96	125	141	165	193	499	520	538	528	597	670
<b>Shipping dimensions</b>													
Without accessories	[cm]	31x81x53	31x81x53	31x81x53	61x81x51	48x107x61	61x81x51	61x122x74	64x122x74	64x122x74	61x122x74	81x152x97	79x155x97
	inch	12x32x21	12x32x21	12x32x21	24x32x20	19x42x24	24x32x20	24x48x29	25x48x29	25x48x29	24x48x29	32x60x38	31x61x38

### Standard equipment for complete machines:

Rotating ring set, heavy drive (pneumatic, hydraulic or electric), self squaring mounting system, set of extension legs, parting tool slide, beveling tool slide, star wheel feed mechanism, fitted storage case, operating hand tools, operating manuals.

LCSF 206/3 up to 814/3 contain 1.5HP 1.1 kW pneumatic motor. LCSF 1016/3 up to 4248/3 contain 2.5 HP 1.8 kW pneumatic motor.

LCSF 206/3 up to 1420/3 contain extended (1.5 inch) parting and beveling tool slides. LCSF 1824/3 up to 4248/3 contain super extended (2 inch) parting and beveling tool slides.

### Clamp pads

Rotating ring set		206	408	612	814	1016	1420	1824	2228	2632	3036	3642	4248	
Self squaring mounting system	[jaws]	4	4	4	4	4	4	8	8	8	8	8	8	
	[set of]	4 each	4 each	4 each	4 each	4 each	4 each	8 each	8 each	8 each	8 each	8 each	8 each	
Extension legs	mm	12.7 25.4 38.1 50.8	25.4 50.8	25.4 50.8 76.2	12.7 38.1 63.5	25.4 38.1 63.5	25.4 50.8 76.2	25.4 50.8 76.2	25.4 50.8 76.2	25.4 50.8 76.2	25.4 50.8 76.2	25.4 50.8 76.2	25.4 50.8 76.2	25.4 50.8 76.2
	inch	0.5 1.0 1.5 2.0	1.0 2.0	1.0 1.5 3.0	0.5 1.5 2.5	1.0 1.5 2.5	1.0 2.0 3.0	1.0 2.0 3.0	1.0 2.0 3.0	1.0 2.0 3.0	1.0 2.0 3.0	1.0 2.0 3.0	1.0 2.0 3.0	1.0 2.0 3.0

### Optional equipment

Bridge slide for single point beveling of heavy wall pipe, low clearance tool slides, extended tool slides, worm gear tool slides, pneumatic, hydraulic or electric drive options, extension legs for pipe, elbows and fittings and thin wall applications, tooling for all prep configurations.

### Other specifications

Cutting tool surface speed	18 m/min (60 ft/min)
Drive options	Pneumatic, hydraulic or electric
Air requirements	1.7 m <sup>3</sup> /min at 6.2 bar (65 ft <sup>3</sup> /min at 90 psi)
Hydraulic requirements	31 l/min at 104 bars (8 gal/min at 1,500 psi)
Feed method	Star wheel
Feed rate	Fixed at 0.0026 inch (0.066 mm) per trip
Finish	Hard chrome plating

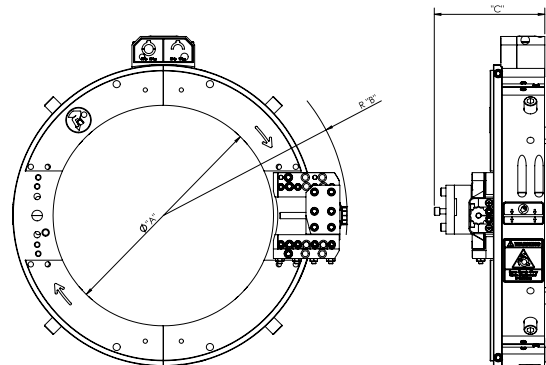

# LCSF Low Clearance Split Frame



Simultaneous parting and beveling



LCSF used in oil and gas



Ideal tool for pipe maintenance and repair projects



LCSF counterboring

## LCSF MACHINE RANGES

ITEM	DRIVETYPE	PIPE OD RANGE		CODE	PART NUMBER
		METRIC MM	NPS INCH		
LCSF 206/3	Pneumatic	50.8 - 168.4	2 - 6	960 247 060	60-AIR-06
LCSF 206/3	Hydraulic	50.8 - 168.4	2 - 6	960 493 060	60-HYD-06
LCSF 206/3	Electric	50.8 - 168.4	2 - 6	ON REQUEST	ON REQUEST
LCSF 408/3	Pneumatic	92.2 - 219.2	4 - 8	960 247 080	60-AIR-08
LCSF 408/3	Hydraulic	92.2 - 219.2	4 - 8	960 493 080	60-HYD-08
LCSF 408/3	Electric	92.2 - 219.2	4 - 8	ON REQUEST	ON REQUEST
LCSF 612/3	Pneumatic	139.7 - 323.85	6 - 12	960 247 120	60-AIR-12
LCSF 612/3	Hydraulic	139.7 - 323.85	6 - 12	960 493 120	60-HYD-12
LCSF 612/3	Electric	139.7 - 323.85	6 - 12	ON REQUEST	ON REQUEST
LCSF 814/3	Pneumatic	196.85 - 355	8 - 14	960 247 140	60-AIR-14
LCSF 814/3	Hydraulic	196.85 - 355	8 - 14	960 493 140	60-HYD-14
LCSF 814/3	Electric	196.85 - 355	8 - 14	ON REQUEST	ON REQUEST
LCSF 1016/3	Pneumatic	247.65 - 406.4	10 - 16	960 247 160	60-AIR-16
LCSF 1016/3	Hydraulic	247.65 - 406.4	10 - 16	960 493 160	60-HYD-16
LCSF 1016/3	Electric	247.65 - 406.4	10 - 16	ON REQUEST	ON REQUEST
LCSF 1420/3	Pneumatic	324 - 508	14 - 20	960 247 200	60-AIR-20
LCSF 1420/3	Hydraulic	324 - 508	14 - 20	960 493 200	60-HYD-20
LCSF 1420/3	Electric	324 - 508	14 - 20	ON REQUEST	ON REQUEST
LCSF 1824/3	Pneumatic	425 - 610	18 - 24	960 247 240	60-AIR-24
LCSF 1824/3	Hydraulic	425 - 610	18 - 24	960 493 240	60-HYD-24
LCSF 1824/3	Electric	425 - 610	18 - 24	ON REQUEST	ON REQUEST
LCSF 2228/3	Pneumatic	527 - 711	22 - 28	960 247 280	60-AIR-28
LCSF 2228/3	Hydraulic	527 - 711	22 - 28	960 493 280	60-HYD-28
LCSF 2228/3	Electric	527 - 711	22 - 28	ON REQUEST	ON REQUEST
LCSF 2632/3	Pneumatic	527 - 711	26 - 32	960 247 320	60-AIR-32
LCSF 2632/3	Hydraulic	527 - 711	26 - 32	960 493 320	60-HYD-32
LCSF 2632/3	Electric	527 - 711	26 - 32	ON REQUEST	ON REQUEST
LCSF 3036/3	Pneumatic	730 - 914	30 - 36	960 247 360	60-AIR-36
LCSF 3036/3	Hydraulic	730 - 914	30 - 36	960 493 360	60-HYD-36
LCSF 3036/3	Electric	730 - 914	30 - 36	ON REQUEST	ON REQUEST
LCSF 3642/3	Pneumatic	883 - 1067	36 - 42	960 247 420	60-AIR-42
LCSF 3642/3	Hydraulic	883 - 1067	36 - 42	960 493 420	60-HYD-42
LCSF 3642/3	Electric	883 - 1067	36 - 42	ON REQUEST	ON REQUEST
LCSF 4248/3	Pneumatic	1035 - 1219	42 - 48	960 247 480	60-AIR-48
LCSF 4248/3	Hydraulic	1035 - 1219	42 - 48	960 493 480	60-HYD-48
LCSF 4248/3	Electric	1035 - 1219	42 - 48	ON REQUEST	ON REQUEST

### TYPICAL STANDARD TOOLING:

Parting tool, e.g. length: 5in (Code 943 711 010, Part Number 43-711-01).  
For further "Cutting tooling" see page 24.

Bevel tool, e.g. 30°, length: 5in (Code 953 703 010, Part Number 53-703-01).  
For further "Bevel tooling" see page 24.

# LCSF Low Clearance Split Frame

## BASIC MACHINE PARTS, NECESSARY FOR CUTTING AND BEVELING:

- Rotating ring set: Version LCSF 1420/3 (Code 960 000 200)
- Right angle air drive (Code 960 423 010)
- ACM (Code 960 420 000) + LCSF air throttle (Code 960 376 000)
- Parting tool, e.g. length: 5" (Code 943 711 010)
- Bevel tool, e.g. 30°, length: 5" (Code 953 703 010)
- Extended (1.5 inch) tool slide set (Code 960 422 010)

## ROTATING RING SETS (SPLIT FRAMES)

Add slides and drive for complete machine. Leg extensions for full clamping range now included with ring.

Includes:

- Self squaring mounting system (4- or 8-jaw)
- Pinion housing assembly
- Operating hand tools
- Carrying case
- Operating manual

ITEM	MODEL	PIPE OD		JAWS	CODE	PART NUMBER
		METRIC MM	NPS INCH	[QTY.]		
Rotating ring set	LCSF 206/3	50.8 - 168.4	2 - 6	4	960 000 060	60-000-06
Rotating ring set	LCSF 408/3	92.2 - 219.2	4 - 8	4	960 000 080	60-000-08
Rotating ring set	LCSF 612/3	139.7 - 323.85	6 - 12	4	960 000 120	60-000-12
Rotating ring set	LCSF 814/3	196.85 - 355	8 - 14	4	960 000 140	60-000-14
Rotating ring set	LCSF 1016/3	247.65 - 406.4	10 - 16	4	960 000 160	60-000-16
Rotating ring set	LCSF 1420/3	324 - 508	14 - 20	4	960 000 200	60-000-20
Rotating ring set	LCSF 1824/3	425 - 610	18 - 24	8	960 000 240	60-000-24
Rotating ring set	LCSF 2228/3	527 - 711	22 - 28	8	960 000 280	60-000-28
Rotating ring set	LCSF 2632/3	629 - 813	26 - 32	8	960 000 320	60-000-32
Rotating ring set	LCSF 3036/3	730 - 914	30 - 36	8	960 000 360	60-000-36
Rotating ring set	LCSF 3642/3	883 - 1067	36 - 42	8	960 000 420	60-000-42
Rotating ring set	LCSF 4248/3	1035 - 1219	42 - 48	8	960 000 480	60-000-48

## DRIVE MOTORS AND EQUIPMENT

Add one of the following to rotating ring:

ITEM	FOR LCSF MODELS	CODE	PART NUMBER
Right angle air drive. 1.1 kW (1.5 hp).	206/3 - 814/3	960 423 000	60-423-00
Right angle air drive. 1.9 kW (2.5 hp).	1016/3 - 4248/3	960 423 010	60-423-01
Hydraulic drive.	204/3 - 4248/3	960 424 010	60-424-01
Hydraulic motor. For usage of LCSF Split Frames operating with hydraulic power unit (see page 72).	204/3 - 4248/3	960 424 020	60-424-02
Air Control Module ACM (see page 76).	For all models	960 420 000	60-420-00
Hydraulic hoses. 1 pair, Length: 15 m (49.2 ft)	For all models	790 500 510	03-404-00
Front drive pinion housing.	408/3 to 1420/3	960 425 030	60-425-03
Front drive pinion housing.	1824/3 to 4248/3	960 425 040	60-425-04
Air treatment module (DWE10).	For all models	790 093 060	26-407-00
Compressed air drive 2.5 HP complete, reversible	For all models	960 401 001	60-4010-01
EPD Electric Power Drives for LCSF, see page 74.	-	-	-



Rotating ring set



NEW: Electric Power Drive (EPD), see page 74



Pneumatic drive motor



Hydraulic drive motor

# LCSF Low Clearance Split Frame

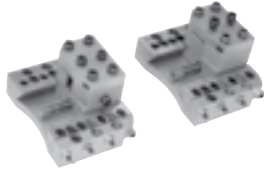

LCSF extended tool slide set

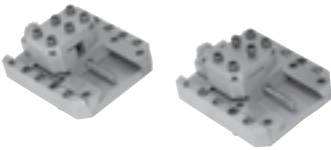

LCSF super extended tool slide set



Worm gear slides for Heavy wall pipe

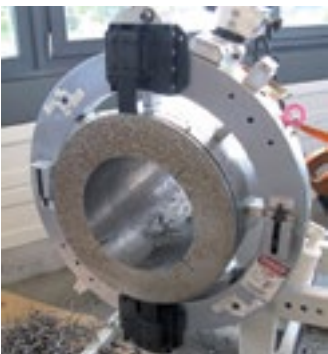

LCSF with worm slide assembly

## TOOL SLIDE ASSEMBLIES

Add one of the following tool slide assemblies to the rotating ring:

ITEM	CODE	PART NUMBER
<b>Low clearance tool slide set.</b> For LCSF 206/3 to LCSF 1420/3. Includes: 1 low clearance parting tool slide (Code 960 402 040) 1 low clearance beveling tool slide (Code 960 403 040) 1 star wheel feed trip mechanism (Code 960 401 000)	960 421 040	60-421-04
<b>Extended (1.5 inch) tool slide set.</b> For LCSF 206/3 to LCSF 1420/3 and low clearance slides for LCSF 1824/3 to LCSF 4248/3. Includes: 1 extended (1.5 inch) parting tool slide (Code 960 415 000) 1 extended (1.5 inch) beveling tool slide (Code 960 416 000) 1 star wheel feed trip mechanism (Code 960 401 000) 2 star wheel feed extension blocks (Code 960 417 000)	960 422 010	60-422-01
<b>Super extended (2 inch) tool slide set.</b> For LCSF 1824/3 to LCSF 4248/3. Includes: 1 super extended (2 inch) parting tool slide (Code 960 437 000) 1 super extended (2 inch) beveling tool slide (Code 960 438 000) 1 star wheel feed trip mechanism (Code 960 434 000) 2 star wheel feed extension blocks (Code 960 439 000)	960 440 000	60-440-00

## WORM SLIDE ASSEMBLIES

For LCSF 1824/3 up to LCSF 4248/3.

Recommended for heavy wall applications > 1.5" (38.1 mm).

ITEM	CODE	PART NUMBER
<b>Worm slide starter kit "parting".</b> Includes: 1 worm slide kit (Code 960 430 000) 1 worm slide heavy wall parting holder kit (Code 960 433 000) 2 heavy wall carbide insert tooling kit (Code 960 712 000) 10 insert tool bits 8 mm/0.313" (Code 960 713 000)	900 002 008	-
<b>Worm slide kit.</b> Includes: 1 parting slide (Code 960 430 010) 1 bevel slide (Code 960 430 020) 2 trip assemblies (Code 960 431 000) with 2 extension blocks (Code 960 432 000) spare fasteners. Utilizes all standard LCSF parting and beveling blades. Note: heavy wall parting > 1.5" (38.1 mm) requires parting tool holder kit (Code 960 433 000) and carbide parting tooling kit (Code 960 712 000).	960 430 000	60-430-00
<b>Worm slide heavy wall parting holder kit.</b> Includes: 1 each low and high insert holder 1 cover fasteners. Utilizes carbide insert holders (Code 960 712 000).	960 433 000	60-433-00
<b>Heavy wall carbide insert tooling kit.</b> Includes: 1 insert holder 1 insert (Code 960 713 000) 1 insert extractor. Used with the worm slides (Code 960 430 000) or spring slides (Code 960 446 000). For 24" - 48" (609.6 - 1219.2 mm) LCSF machines.	960 712 000	60-712-00
<b>Insert tool bit 0.313" (8 mm).</b> For use with tooling kit (Code 960 712 000).	960 713 000	60-713-00

# LCSF Low Clearance Split Frame

## OD TRACKING SLIDES

OD tracking module.

ITEM	FOR LCSF MODELS	CODE	PART NUMBER
<b>OD tracking tool slide set.</b> Includes: 2 OD tracking tool slides: 1 tool slide parting (960 446 010) and 1 tool slide parting/beveling (960 446 020) 1 trip assembly with corrosion protection (Code 960 446 030) Fasteners	1824/3 - 4248/3	960 446 000	60-446-00
<b>Parting tool slide, OD tracking.</b>	1824/3 - 4248/3	960 446 010	60-446-01
<b>Beveling tool slide, OD tracking.</b>	1824/3 - 4248/3	960 446 020	60-446-02
<b>OD tracking trip.</b>	1824/3 - 4248/3	960 446 030	60-446-03
<b>OD tracking tool slide set.</b>	610/3 - 1420/3	960 451 000	60-451-00



Out of round slides

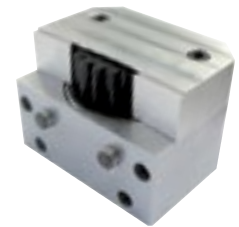

Pinion housing assembly



Front drive pinion housing

## PINION HOUSING ASSEMBLIES

Included in LCSF ring sets.

ITEM	FOR LCSF MODELS	CODE	PART NUMBER
<b>Pinion housing assembly.</b>	LCSF 206/3 - LCSF 1420/3	960 412 000	60-412-00
<b>Pinion housing assembly.</b>	LCSF 1824/3, LCSF 2228/3, LCSF 2632/3, LCSF 3036/3, LCSF 3642/3, LCSF 4248/3	960 409 000	60-409-00
<b>Front drive pinion housing.</b>	LCSF 408/3 - LCSF 1420/3	960 425 030	60-425-03
<b>Front drive pinion housing.</b>	LCSF 1824/3 - LCSF 4248/3	960 425 040	60-425-04

## TRIP ASSEMBLY

Upgrades LCSF Split Frame Machines for safer operation (included in tool slide sets, opposite page).

ITEM	FOR LCSF MODELS	CODE	PART NUMBER
<b>Trip Assembly.</b>	LCSF 206-1420	960 401 000	60-401-00
<b>Trip Assembly.</b>	LCSF 1824-4248	960 434 000	60-434-00



Trip Assembly

## SINGLE SIZE EXTENSION LEG SETS

LCSF 206/3 up to LCSF 1420/3: 1 set of 4 each.

LCSF 1824/3 up to LCSF 4248/3: 2 sets of 4 each.

ITEM	DIMENSION		CODE	PART NUMBER
	MM	INCH		
<b>Single size extension leg set</b>	12.7	1/2	960 408 050	60-408-05
<b>Single size extension leg set</b>	19.1	3/4	960 408 070	60-408-07
<b>Single size extension leg set</b>	25.4	1	960 408 100	60-408-10
<b>Single size extension leg set</b>	38.1	1 1/2	960 408 150	60-408-15
<b>Single size extension leg set</b>	50.8	2	960 408 200	60-408-20
<b>Single size extension leg set</b>	63.5	2 1/2	960 408 250	60-408-25
<b>Single size extension leg set</b>	76.2	3	960 408 300	60-408-30



Single size extension leg set

# LCSF Low Clearance Split Frame



Universal counterbore slide

## UNIVERSAL COUNTERBORE SLIDE ASSEMBLIES

Max. axial travel: 1 3/4in (44.5 mm). Mounts to bevel tool slide.

ITEM	CODE	PART NUMBER
Universal counterbore slide module for WACHS LCSF.	960 405 820	60-405-UC
Counterbore tool bit taper 4:1 (14°) for use with counterbore slide module	960 700 040	60-700-04

## BRIDGE SLIDE ASSEMBLIES

For single point beveling applications over 1.25in (32 mm) wall and counterboring.

Max. axial travel for counterboring: 1 1/2in (38.1 mm).

Includes:

- 1 storage case (bridge slide assembly 12-20 only)
- 1 operating manual
- 1 counterbore tool holder (Code 960 708 000)
- 1 single point tool holder (Code 960 707 000)
- 1 counterbore tool (4:1 taper) (Code 960 700 040)
- 1 single point tool bit (Code 952 701 010)
- operating hand tools



Bridge slide for thick-walled welding preparations

## ADDITIONAL TEMPLATE REQUIRED: BRIDGE SLIDE ASSEMBLY FOR THICK-WALLED PREPARATIONS

SIZE	FOR USE WITH	CODE	PART NUMBER
12 LC	LCSF 612/3	960 428 120	60-428-12
12-14	LCSF 612/3, LCSF 814/3	960 428 140	60-428-14
12-16	LCSF 612/3, LCSF 814/3, LCSF 1016/3	960 428 160	60-428-16
12-20	LCSF 612/3, LCSF 814/3, LCSF 1016/3, LCSF 1420/3	960 428 200	60-428-20
24 LC	LCSF 1824/3	960 428 240	60-428-24
24-28	LCSF 1824/3, LCSF 2228/3	960 428 280	60-428-28
32 LC	LCSF 2632/3	960 428 320	60-428-32
32-36	LCSF 2632/3, LCSF 3036/3	960 428 360	60-428-36
42 LC	LCSF 3642/3	960 428 420	60-428-42
42-48	LCSF 3642/3, LCSF 4248/3	960 428 480	60-428-48



# LCSF Low Clearance Split Frame

## BRIDGE SLIDE TEMPLATES

Please specify when ordering customized templates:

Beveling angles (primary/secondary), OD, transition diameter.

ITEM	BEVELING ANGLE DEGREES (°)	CODE	PART NUMBER
Bridge slide template	37.5	953 409 020	53-409-02
Bridge slide template	30	953 409 030	53-409-03
Bridge slide template	20	953 409 050	53-409-05
Bridge slide template	10 x 37.5	953 409 110	53-409-11
Bridge slide template	10 x 30	953 409 120	53-409-12
Bridge slide template	10 x 20	953 409 130	53-409-13
<b>Customized bridge slide templates</b>			
<b>Custom bridge slide templates.</b> 2 single angle templates included.	–	ON REQUEST	60-SPP-01
<b>Custom bridge slide templates.</b> 2 compound angle templates included.	–	ON REQUEST	60-SPP-02

## BRIDGE SLIDE TOOLING

Please specify when ordering customized tools:

OD, wall, finished bore, depth, lead-in angle, marking, radius.

ITEM	CODE	PART NUMBER
<b>DuoEdge LCSF single point holder</b> single pack (see page 26).	960 718 000	60-718-00
<b>Counterbore tool holder.</b> 1" (25.4 mm) square shank. For use with counterbore tool bit (Code 960 700 040).	960 708 000	60-708-00
<b>Counterbore tool (4:1 taper).</b> For use with WACHS LCSF/3 machines.	960 700 040	60-700-04
<b>Single point tool holder (SW tool, 3/8" x 3/8").</b> 1" (25.4 mm) square shank. For use with single point tool bit (Code 952 701 010).	960 707 000	60-707-00
<b>Single point tool bit.</b> For facing, beveling and flange facing. Standard HSS tool bit 3/8" x 3/8" (9.5 x 9.5 mm). For use with EP 424, LCSF/3, FF, SWR and SDSF machines.	952 701 010	52-701-01
<b>Customized tools</b>		
<b>Custom counterbore tool bit (HSS).</b> For LCSF 204/3 to LCSF 1420/3 counterbore slide. 1/4" x 1 1/4" (6.35 x 31.75 mm) stock.	ON REQUEST	60-SPT-14
<b>Custom single edge radius tool bit (HSS).</b> 3/8" x 3/8" (9.5 x 9.5 mm) square stock.	ON REQUEST	60-SPT-15



Bridge slide template for thick-walled welding preparations

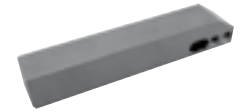

Legacy single-point tool holder (SW tool, 3/8" x 3/8")



Counterbore tool holder



Legacy single-point standard HSS tool bit 9.5 x 9.5 mm

# LCSF Low Clearance Split Frame



Parting blade



Parting blade Premium (coated)

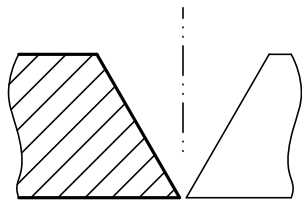

Bevel without land

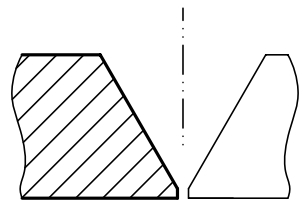

Bevel with land



Bevel tool inside 30°



Bevel tool outside 30°



Bevel tool double 30°

## CUTTING TOOLING

ITEM	WIDTH		LENGTH		MADE FROM	CODE	PART NUMBER
	MM	INCH	MM	INCH			
Insert holder for parting insert	4.8	3/16			CARBIDE	943 704 000	43-704-00
Parting insert	4.8	3/16			CARBIDE	943 705 000	43-705-00
Insert holder for parting insert	6.4	1/4			CARBIDE	947 701 000	47-701-00
Parting insert	6.4	1/4			CARBIDE	947 702 000	47-702-00
Parting blade	4.8	3/16	87.3	3.44	HSS	943 711 000	43-711-00
Parting blade	4.8	3/16	127	5	HSS	943 711 010	43-711-01
Parting blade Premium (coated)	4.8	3/16	127	5	HSS	943 711 019	43-711-01P
Parting blade for use with all slides including worm slides (Code 960 430 000).	6.4	1/4	152.4	6	HSS	960 711 000	60-711-00
Insert holder kit for heavy walls. Includes: 1 insert holder 1 insert (Code 960 713 000) 1 insert extractor. Used with worm slides (960 430 000) or spring slides (960 446 000). For 24" - 48" (609.6 - 1219.2 mm) LCSF machines.					CARBIDE	960 712 000	60-712-00
Insert 0.313" (8 mm). Used with insert holder kit (Code 960 712 000).					CARBIDE	960 713 000	60-713-00
<b>Customized parting blades</b>							
Custom parting blade	4.8	3/16	127	5	HSS	ON REQUEST	60-SPT-11
Custom parting blade	6.4	1/4	127	5	HSS	ON REQUEST	60-SPT-12
Custom parting blade for bevel slides	12.7	1/2	19.05	3/4	HSS	ON REQUEST	60-SPT-13

## BEVEL TOOLING

To utilize up to wall thicknesses of 1 ¼ inch (32 mm).

Please specify when ordering customized tools: OD, wall, primary angle, land.

ITEM	BEVELING ANGLE	LENGTH		CODE	PART NUMBER	
	[DEGREES °]	MM	INCH			
Bevel tool inside	30	79.4	3.125	943 702 050	43-702-05	
Bevel tool outside	30	79.4	3.125	943 707 050	43-707-05	
Bevel tool double	30	79.4	3.125	943 709 050	43-709-05	
Bevel tool inside	30	127	5	953 703 010	53-703-01	
Bevel tool inside Premium (coated)	30	127	5	953 703 019	53-703-01P	
Bevel tool outside	30	127	5	943 707 060	43-707-06	
Bevel tool double	30	127	5	943 709 060	43-709-06	
Bevel tool inside	37.5	79.4	3.125	943 703 050	43-703-05	
Bevel tool outside	37.5	79.4	3.125	943 708 050	43-708-05	
Bevel tool double	37.5	79.4	3.125	943 710 050	43-710-05	
Bevel tool inside	37.5	127	5	953 703 000	53-703-00	
Bevel tool outside (replaces 953 707 000)	37.5	127	5	943 708 060	43-708-06	
Bevel tool double (replaces 953 708 000)	37.5	127	5	943 710 060	43-710-06	
<b>CUSTOMIZED TOOLS</b>						
	WIDTH		LENGTH STOCK		CODE	PART NUMBER
	MM	INCH	MM	INCH		
Custom bevel tool bit single angle (HSS)	19.05	3/4	87.3	3.438	ON REQUEST	60-SPT-01
Custom bevel tool bit single angle outside (HSS)	38.1	1 ½	87.3	3.438	ON REQUEST	60-SPT-03
Custom bevel tool bit double (HSS)	38.1	1 ½	87.3	3.438	ON REQUEST	60-SPT-05
Custom bevel tool bit single angle (HSS)	19.05	3/4	127	5	ON REQUEST	60-SPT-02
Custom bevel tool bit single angle outside (HSS)	38.1	1 ½	127	5	ON REQUEST	60-SPT-04
Custom bevel tool bit double (HSS)	38.1	1 ½	127	5	ON REQUEST	60-SPT-06

# LCSF Low Clearance Split Frame

## COMPOUND BEVEL TOOLING

Please specify when ordering customized tools:

OD, wall, primary angle, secondary angle, land, land extension, transition, radius.

ITEM	BEVEL ANGLE	LENGTH		CODE	PART NUMBER	
	DEGREES (°)	MM	INCH			
Bevel tool inside.	10 x 37.5	101.6	4	943 712 010	43-712-01	
Bevel tool outside.	10 x 37.5	101.6	4	943 712 020	43-712-02	
Bevel tool inside. Max. wall. 1¼" (31.75 mm) or 1.188" (30 mm) when used with parting slides 960 416 000 or 960 437 000.	10 x 37.5	127	5	953 705 000	53-705-00	
Bevel tool inside. Max. wall. 2.125" (54 mm).	10 x 30	127	5	953 704 000	53-704-00	
CUSTOMIZED TOOLS	WIDTH		LENGTH STOCK		CODE	PART NUMBER
	MM	INCH	MM	INCH		
Custom bevel tool bit compound (HSS).	19.05	3/4	127	5	ON REQUEST	60-SPT-07
Custom bevel tool bit single angle "J" (HSS).	19.05	3/4	127	5	ON REQUEST	60-SPT-08
Custom bevel tool bit compound angle "J" (HSS).	19.05	3/4	127	5	ON REQUEST	60-SPT-09

## COUNTERBORE TOOLING

Please specify when ordering customized tools:

OD, wall, finished bore, depth, lead-in angle, marking.

ITEM	CODE	PART NUMBER
Counterbore tool (4:1 taper). For use with WACHS LCSF/3 machines.	960 700 040	60-700-04
<b>Customized tools</b>		
Custom counterbore tool bit (HSS). For LCSF 204/3 to LCSF 1420/3 counterbore slide 1/4" x 1¼" (6.35 x 31.75 mm) stock.	ON REQUEST	60-SPT-14

## CUTTING LUBRICATION

Cutting lubrication "KSS-TOP", see page 48.

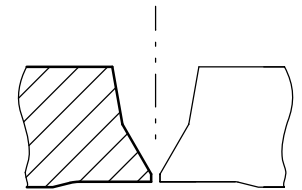

Compound Bevel

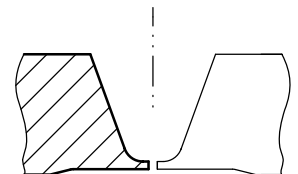

J-Prep Bevel

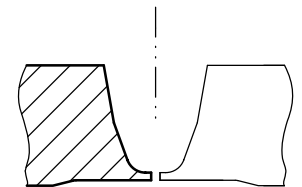

Compound J-Prep Bevel



Compound tool



J-prep tool

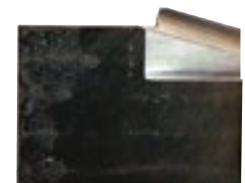

Counterbore tool taper 4:1

# LCSF Low Clearance Split Frame



NEW DuoEdge LCSF insert and holder



DuoEdge inserts, 10 pack



LCSF DuoEdge reusable holder

## NEW DUOEDGE INSERT TOOLING

E.H. WACHS DuoEdge Insert Tooling is a system of portable machine tool holders and inserts designed to replace larger, more expensive traditional single edge tooling.

It offers considerable cost savings over traditional tooling without sacrificing the longevity of the cutting edge or the quality of the finished prep.

- Two cutting edges instead of one, for minimal work interruption
- Each cutting edge costs on average one third the cost of a traditional bit
- No need to resharpen tooling, saving time, labor and shipping
- Small size of inserts makes them easy to store or carry in your pocket
- Holders are reusable, inserts are interchangeable between holders
- End prep holder is reversible to a high and low range position
- Precision ground, super smooth surface finish
- Reduced friction for longer life
- Chip curl edge designed to clear swarf
- Eliminates expensive and time consuming conventional tool resharpening
- Unlike conventional tooling DuoEdge has two cutting edges per insert
- Less expensive per cutting edge, on average less than 1/3 the cost of conventional tooling
- Optimal mix of sharpness and durability
- Supplied with R0.5" tool radius for stronger edges and a better finish
- Superior to competitors off the shelf repurposed CNC tooling
- Three insert materials offered, HSS, premium coated HSS and carbide steel

ITEM	APPLICATION	MATERIAL	CODE	PART NUMBER
DuoEdge Insert Single Pack	Carbon steel	HSS	981 701 010	81-701-01
DuoEdge Insert 10-Pack	Carbon steel	HSS	981 701 100	81-701-10
DuoEdge Premium Single Pack	Stainless steel	HSS Premium	981 701 009	81-701-00P
DuoEdge Premium 10-Pack	Stainless steel	HSS Premium	981 701 109	81-701-10P
DuoEdge Insert Single Pack	High-temp alloys	Carbide	981 703 010	81-703-01
DuoEdge Insert 10-Pack	High-temp alloys	Carbide	981 703 100	81-703-10
DuoEdge J-Prep Insert Single Pack	R 2.4 mm/.094" J-Prep	HSS	981 704 010	81-704-01
DuoEdge J-Prep Insert Single Pack	R 3.2 mm/.125" J-Prep	HSS	981 705 010	81-705-01
DuoEdge J-Prep Insert Single Pack	R 4.8 mm/.188" J-Prep	HSS	981 706 010	81-706-01
DuoEdge J-Prep Insert Single Pack	R 6 mm/.236" J-Prep	HSS	981 707 010	81-707-01
LCSF Holder Single Pack	LCSF single point	Heat treated steel	960 718 000	60-718-00