



"innovation in its most functional form"

## PRODUCT DATA SHEET

# VLW18TI

## INTEGRAL HYDRAULIC VERTICAL LIFTING WEDGE

LIFTING FORCE:  
10,000 psi (700 bar) = 18 T (180 kN)

TOOL WEIGHT = 12 kg (26.5 lbs)

### KIT COMPONENTS

- 1 x VLW18TI Wedgehead
  - 1 x 10,000 psi (700 bar) Integral Hydraulic Pump/Cylinder
  - 1 x Safety Block
  - 1 x Stepped Block
  - 1 x Hex Key
  - 1 x Countersunk Screw
  - 1 x Instruction Manual
  - 1 x Carry Case
- Product Code: VLW18TISPB



### WEIGHTS AND DIMENSIONS

Tool Weight = 12 kg (26.5 lbs)  
Case Weight = 2.5 kg (5.5 lbs)  
Gross Weight = 14.5 kg (31.9 lbs)

Carry Case Dimensions:  
580 x 340 x 180mm (22.8" x 13.4" x 7.1")

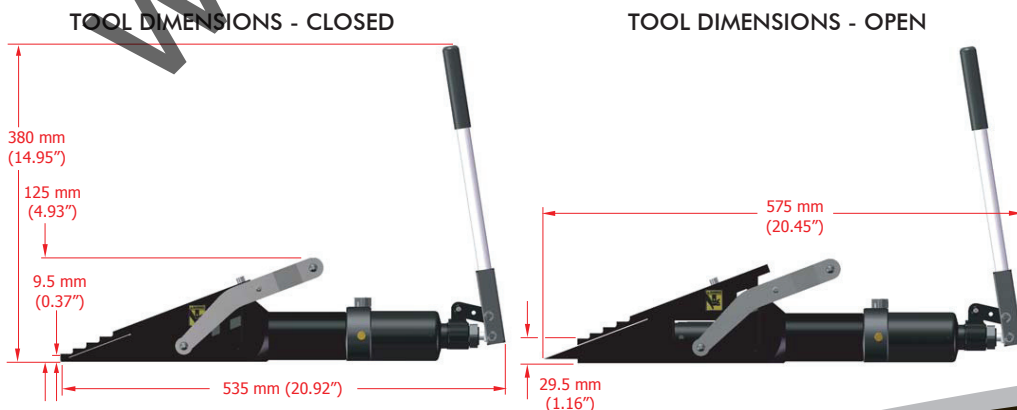

info@equalizerinternational.com  
www.equalizerinternational.com

# VLW18TI

INTEGRAL HYDRAULIC VERTICAL LIFTING WEDGE



"innovation in its most functional form"

## TOOL DIMENSIONS - CLOSED

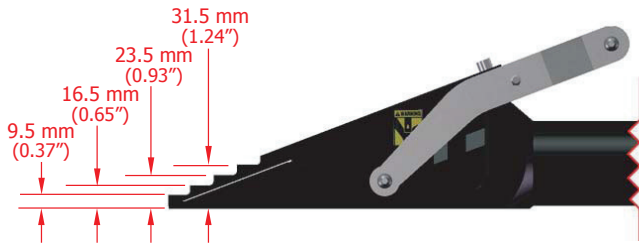

## TOOL DIMENSIONS - OPEN

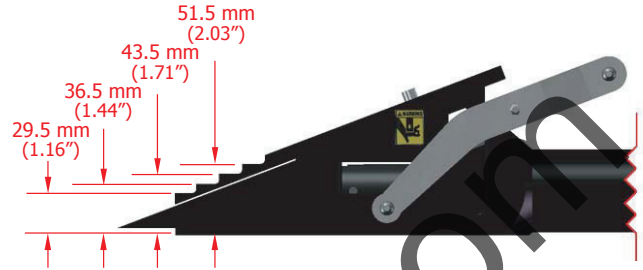

## SAFETY BLOCK DIMENSIONS

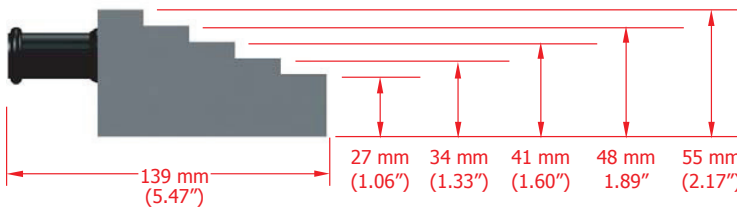

## STEPPED BLOCK DIMENSIONS

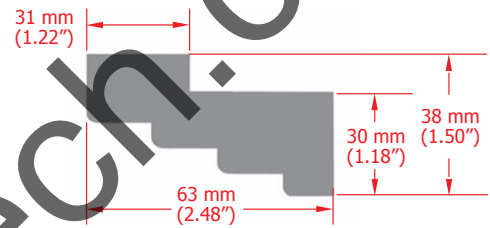

## PARTS LIST AND EXPLODED DRAWING

ITEM	PART No.	DESCRIPTION	QUANTITY
01	060701-01	ALLEN KEY	01 each
02	070012-01	SERIAL NO STICKER	01 each
03	070014-01	PINCH POINT STICKER	02 each
04	070054-01	QC SEALED STICKER	02 each
05	070098-01	EQUALIZER LOGO	01 each
06	070249-01	READ INSTRUCTION STICKER	01 each
07	201203-01	HANDLE SLEEVE	01 each
08	300401-01	SCKT SET SCREW	02 each
09	301201-01	SPIROL PIN	04 each
10	301301-01	GRUB SCREW	01 each
11	310601-01	GREASE NIPPLE	01 each
12	402701-01	SCKT HEAD CAP SCREW	01 each
13	402902-01	SCREW FOR HANDLE	05 each
14	500101-01	MAIN BODY	01 each
15	500201-01	TOP PLATE	01 each
16	500302-01	WEDGE TAIL	01 each
17	500401-01	GUIDE PIN	02 each
18	500503-01	PUSH PIN MK III	01 each
19	501101-01	HANDLE LEFT	01 each
20	501201-01	HANDLE RIGHT	01 each
21	501301-01	HANDLE BAR	01 each
22	501401-01	SAFETY BLOCK	01 kit
23	501601-01	WASHER FOR TAIL	01 each
24	501901-01	STEP BLOCK	01 each
25	502301-01	GRUB SCREW	01 each
26	503201-01	SLOT PLUG	01 each
27	503301-01	WASHER	02 each
28	503401-01	WASHER	02 each
29	503501-01	SPACER	02 each
30	510701-01	PUMP MODEL PM1004UK	01 each
31	375010-01	SERVICE KIT A (not illustrated)	01 each
32	375020-01	SERVICE KIT C (not illustrated)	01 each
33	510700-01	SERVICE KIT D (not illustrated)	01 each

