

Double nut with flange FDM-E-S

Rexroth connection dimensions

With seals,
preload class: C4, C5
Tolerance grades T3²⁾, T5, T7

Note: Supplied only as complete
Ball Screw Assembly.

⚠ When setting up applications, do
not allow components to collide with the
front lube unit.

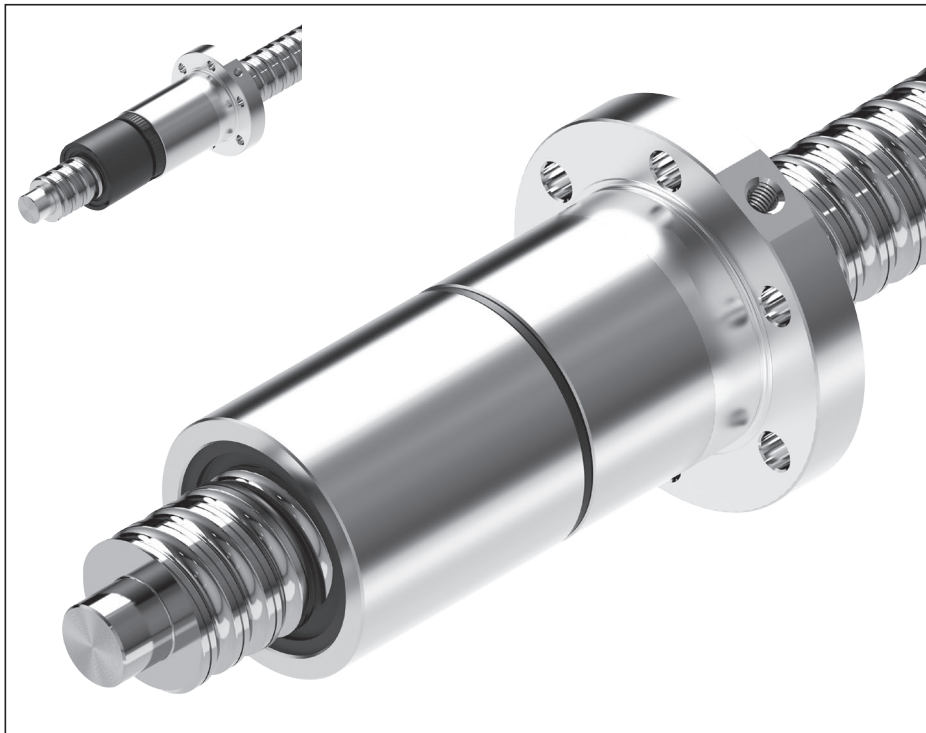

d_0 = nominal diameter
 P = lead (R = right-hand)
 D_w = ball diameter
 i = number of ball track turns

Ordering data:

BASA	20 x 5R x 3	FDM-E-S - 4	00	1	5	T7	R	82Z120	41Z120	1250	0	1
------	-------------	-------------	----	---	---	----	---	--------	--------	------	---	---

Category	Size $d_0 \times P \times D_w - i$	Part number	Load ratings ³⁾		Linear speed ¹⁾ v_{max} (m/min)
			dyn. C (N)	stat. C ₀ (N)	
C	16 x 5R x 3 - 4	R1502 010 23	14,800	16,100	30
C	20 x 5R x 3 - 4	R1502 110 33	17,200	21,500	30
C	25 x 5R x 3 - 4	R1502 210 33	19,100	27,200	30
C	25 x 10R x 3 - 4	R1502 240 33	18,800	27,000	60
C	32 x 5R x 3.5 - 4	R1502 310 33	25,900	40,000	23
C	32 x 10R x 3.969 - 5	R1502 340 33	38,000	58,300	47
C	40 x 5R x 3.5 - 5	R1502 410 33	34,900	64,100	19
C	40 x 10R x 6 - 4	R1502 440 33	60,000	86,400	38
C	40 x 10R x 6 - 6	R1502 440 34	86,500	132,200	38
C	40 x 20R x 6 - 3	R1502 470 33	45,500	62,800	75
C	50 x 5R x 3.5 - 5	R1502 510 33	38,400	81,300	15
C	50 x 10R x 6 - 4	R1502 540 33	66,500	109,000	30
C	50 x 10R x 6 - 6	R1502 540 34	95,600	166,500	30
C	50 x 20R x 6.5 - 5	R1502 570 34	90,800	149,700	60
C	63 x 10R x 6 - 4	R1502 640 33	74,200	140,500	24
C	63 x 10R x 6 - 6	R1502 640 34	106,600	214,300	24
C	63 x 20R x 6.5 - 5	R1502 670 34	100,700	190,300	48
C	80 x 10R x 6.5 - 6	R1502 740 34	130,100	291,700	19
C	80 x 20R x 12.7 - 6	R1502 770 04	315,200	534,200	30

- 1) See "Characteristic speed $d_0 \cdot n$ " on page 141 and "Critical speed n_{cr} " on page 176
- 2) Tolerance grade T3 for sizes shown in table page 12
- 3) The load ratings are valid for tolerance grade T3 and T5 only.
For other tolerance grades, please take into account the correction factor f_{ac} on page 141.

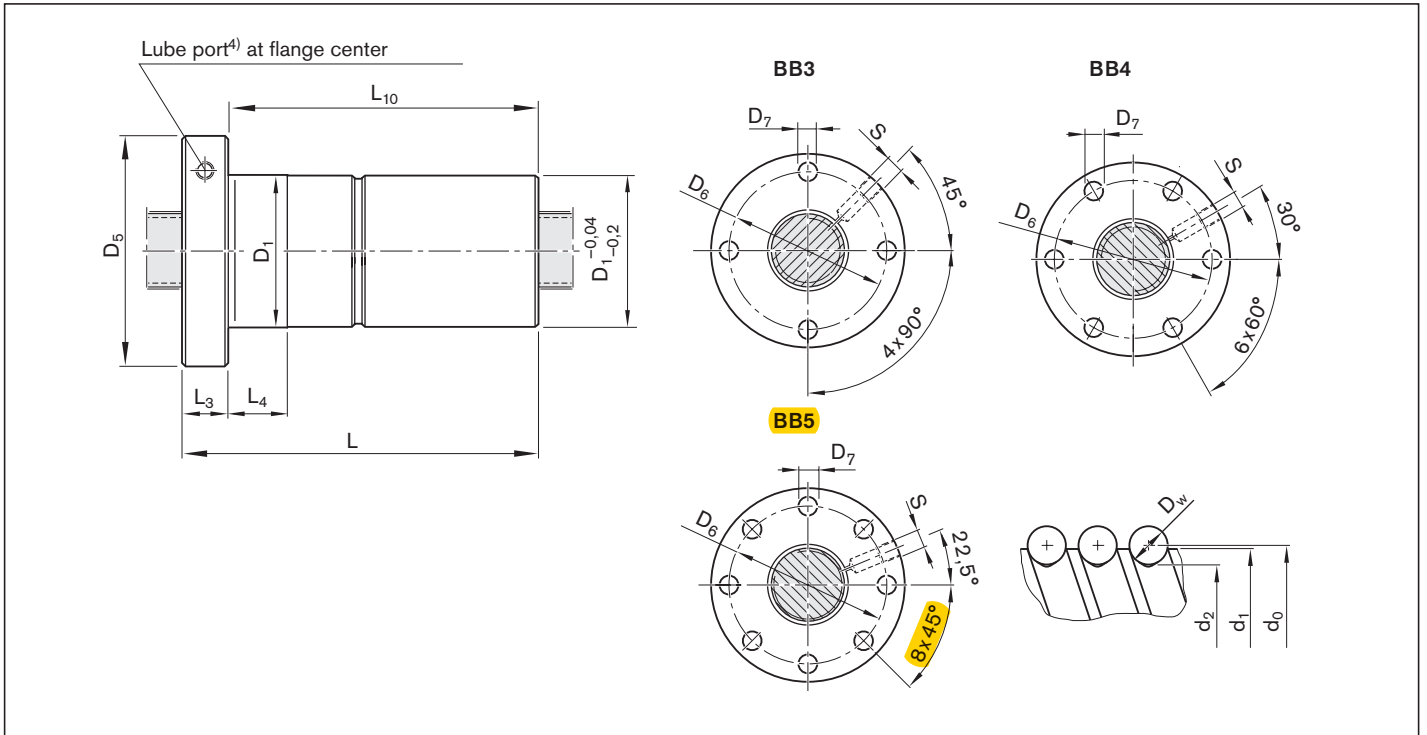

4) Lube port machining: flat surface $L_3 \leq 15$ mm, countersink $L_3 > 15$ mm

Size	(mm)												Mass	
	d_1	d_2	D_1 g6	D_5	Hole pattern	D_6	D_7	L	L_3	L_4	L_{10}	$S^4)$	m (kg)	
$d_0 \times P \times D_w - i$														
16 x 5R x 3 - 4	15.0	12.9	28	53	BB3	40	6.6	72	12	10	60	M6	0.33	
20 x 5R x 3 - 4	19.0	16.9	33	58	BB4	45	6.6	82	12	10	70	M6	0.45	
25 x 5R x 3 - 4	24.0	21.9	38	63	BB4	50	6.6	82	12	10	70	M6	0.53	
25 x 10R x 3 - 4	24.0	21.9	38	63	BB4	50	6.6	120	12	16	108	M6	0.70	
32 x 5R x 3.5 - 4	31.0	28.4	48	73	BB4	60	6.6	88	13	10	75	M6	0.84	
32 x 10R x 3.969 - 5	31.0	27.9	48	73	BB4	60	6.6	146	13	16	133	M6	1.22	
40 x 5R x 3.5 - 5	39.0	36.4	56	80	BB4	68	6.6	100	15	10	85	M8x1	1.13	
40 x 10R x 6 - 4	38.0	33.8	63	95	BB4	78	9.0	140	15	16	125	M8x1	2.25	
40 x 10R x 6 - 6	38.0	33.8	63	95	BB4	78	9.0	180	15	16	165	M8x1	2.83	
40 x 20R x 6 - 3	38.0	33.8	63	95	BB4	78	9.0	175	15	25	160	M8x1	2.66	
50 x 5R x 3.5 - 5	49.0	46.4	68	98	BB4	82	9.0	100	15	10	85	M8x1	1.60	
50 x 10R x 6 - 4	48.0	43.8	72	110	BB4	90	11.0	140	18	16	122	M8x1	2.74	
50 x 10R x 6 - 6	48.0	43.8	72	110	BB4	90	11.0	180	18	16	162	M8x1	3.39	
50 x 20R x 6.5 - 5	48.0	43.4	85	125	BB4	105	11.0	255	22	25	233	M8x1	6.71	
63 x 10R x 6 - 4	61.0	56.8	85	125	BB4	105	11.0	140	22	16	118	M8x1	3.53	
63 x 10R x 6 - 6	61.0	56.8	85	125	BB4	105	11.0	180	22	16	158	M8x1	4.32	
63 x 20R x 6.5 - 5	61.0	56.3	95	140	BB4	118	14.0	255	22	25	233	M8x1	8.65	
80 x 10R x 6.5 - 6	78.0	73.3	105	150	BB4	125	14.0	190	22	16	168	M8x1	6.35	
80 x 20R x 12.7 - 6	76.0	67.0	125	180	BB5	152	18.0	340	25	25	315	M8x1	20.20	