

392

WASHING MACHINE BALL VALVE



SIZE	PRESSURE	CODE	PACKING
1/2" (DN 15)	16bar/232psi	3920012	10/160

TECHNICAL SPECIFICATIONS

Metal handle.

Available size: 1/2"x3/4".

Male/male thread.

Body in nickel-plated brass.

Minimum and maximum working temperatures: 0°C, 110°C in absence of steam.

Threads ISO228 (equivalent to DIN EN ISO 228 and BS EN ISO 228).

Available also with NPT thread.

MATERIALS

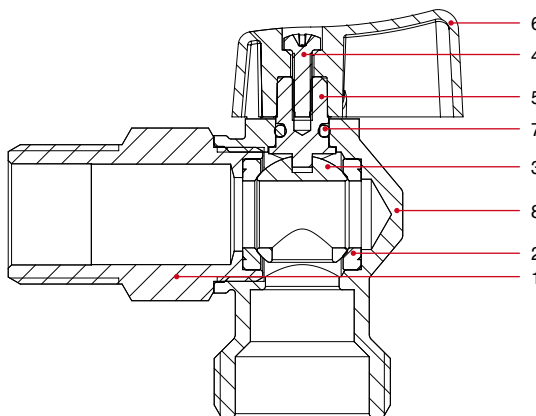

POS.	DESCRIPTION	N.	MATERIAL
1	End adapter	1	Nickel-plated brass CW617N
2	Seat	2	P.T.F.E.
3	Ball	1	Chrome-plated brass CW614N
4	Screw	1	Zinc-plated steel Fe
5	Stem	1	Brass CW614N
6	Handle	1	Zinc-plated aluminium ZnAl4 (Zamak 3)
7	O-ring	1	NBR
8	Body	1	Nickel-plated brass CW617N





TEC

OVERALL DIMENSIONS

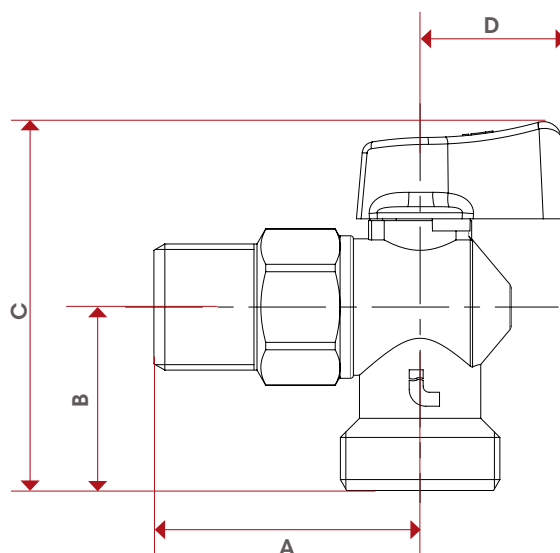

	1/2"
DN	15
A	44
B	30
C	61
D	24
Kg/cm ² bar	16
LBS - psi	232

CERTIFICATIONS



ART. 392