

PRO 40 | Practical drilling machine

PRO 40 is lightweight, one speed and reliable machine which has been proven on many industrialized markets all over the world.

Superior features of PRO40 include:

- compact design
- purpose designed motor with heavy duty gear box
- excellent ratio weight / power

PRO 40 is equipped with the latest generation of electromagnetic energy saving base (ESB) with magnetic field shape control system (MFSC) and magnetic power adhesion control module (MPAC), which measures adhesive force of electromagnetic base and prevents both the machine and the operator from work on workpieces which do not provide enough grip for the magnetic base.

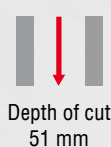



Max
Ø 40 mm
(1 9/16")



Max
Ø 16 mm
(10/16")

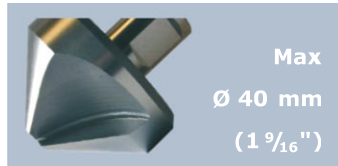

Max
Ø 40 mm
(1 9/16")

PRO 40 TECHNICAL SPECIFICATION

Motor Speed (under load)	440 rpm
Motor Power	1020 W
Weight	12,7 kg (27 lbs 6 oz)
Max milling capacity	Ø 40 mm (1 9/16")
Max drilling capacity	Ø 16 mm (10/16")
Max countersinking	Ø 40 mm (1 9/16")
Stroke	124 mm (4 7/16")
Max depth of cut	51 mm (2")
Voltage	115V/60Hz or 230V/50 Hz
Power consumption	1100 W
MPAC	yes
MFSC	yes
ESB	yes
Magnetic clamping force	999 kG (9800 N) /25mm, Ra=1,25/
Magnet Base Dimensions	84 x 168 x 41,5 [mm] 3 5/16 x 6 5/8 x 1 5/8 ["]
Min. Workpiece Thickness	6 mm (1/4")
Tool holder	19 mm (3/4") Weldon
Product Code 230V/50Hz	WRT-0291-10-20-00-3
Product Code 115V/60Hz	WRT-0291-10-10-00-3

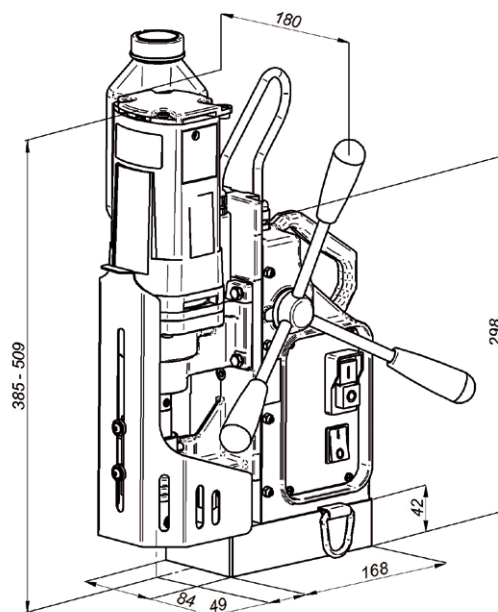

Standard shipping set:

- Magnetic Base Drilling Machine
- Metal Box
- 19 mm (3/4") Weldon Arbor – for cooling through ring
- Swarf Shield/Cutter Guard
- Coolant Bottle Assembly
- Safety Chain
- Set of Tools
- Instruction Manual (English)
- Standard shipping weight – 18 kg (38 lbs 13 oz)

Selected additional accessories:

- UCW-0260-13-00-00-0 Quick Change 19 mm (3/4") Weldon Arbor for cooling through ring
- PDS-0110-10-00-01-0 DMP0250 Pipe Attachment
- PDS-0111-03-00-01-0 DMP0501 Pipe Attachment
- UKL-0399-11-00-00-0 Coolant Bottle Assembly
- UKL-0440-16-00-00-0 Coolant System 2l
- LNC-0129-80-01-00-0 Safety Chain
- TLJ-0197-10-00-03-0 Drill Chuck Adapter x 1/2" - 20 UNF
- UCW-000059 Drilling Chuck 1,5-13 x 1/2" – 20 UNF
- UCW-000061 Drilling Chuck 3-16 x 1/2" – 20 UNF

All information is subject to change without notice. 1508



PROMOTECH Sp. z o.o.
ul. Elewatorska 23/1, 15-620 BIAŁYSTOK, POLAND
tel. (+48 85) 678 34 05, fax (+48 85) 662 78 77
marketing@promotech.eu www.promotech.eu

Your local dealer:

