

# Diaphragm Valve, Metal

## Construction

The GEMÜ 601, 612 and 673 manually operated diaphragm valves have a temperature resistant plastic handwheel, GEMÜ 602 has a stainless steel handwheel. Bonnet and internals are made all of stainless steel. An integral optical position indicator and a seal adjuster to increase service life of the diaphragm are included as standard.

## Features

- Suitable for inert and corrosive\* liquid and gaseous media
- Chemical resistance of bonnet
- CIP/SIP cleaning and sterilizing capabilities
- Autoclave capability
- Insensitive to particulate media
- Valve body and diaphragm available in various materials and designs
- Compact design (ideal when space is at a premium)
- Stepless minimum flow regulation due to seal adjuster

## Advantages

- Hermetic separation between medium and actuator
- Optional flow direction
- Installation for an optimized draining is possible
- Long service life of the diaphragm due to patented seal adjuster (US-Pat. 5 377 956)
- Valve body also available in multi-port designs (M-block and T-body) or as tank bottom valve body

\*see information on working medium on page 2

GEMÜ 601

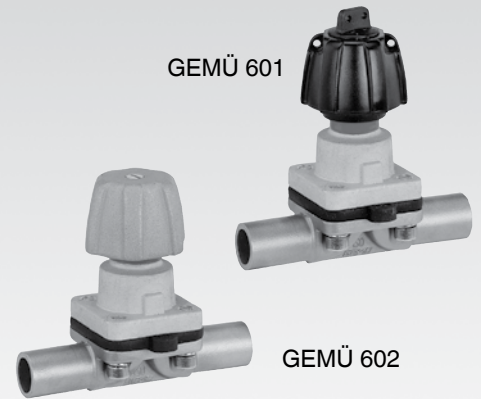

GEMÜ 602



GEMÜ 612



GEMÜ 673

## Sectional drawing

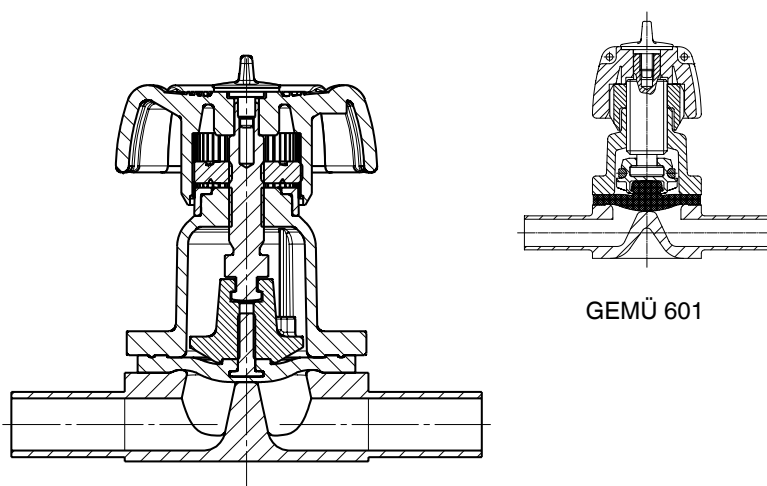

GEMÜ 601

GEMÜ 612

## Technical data

### Working medium

Corrosive, inert, gaseous and liquid media which have no negative impact on the physical and chemical properties of the body and diaphragm material.

### Temperatures

#### Media temperature

FKM (Code 4/4A)	-10 ... 90 °C
EPDM (Code 13/3A)	-10 ... 100 °C
EPDM (Code 17)	-10 ... 100 °C
EPDM (Code 19)	-10 ... 100 °C
EPDM (Code 36)	-10 ... 100 °C
PTFE/EPDM (Code 54)	-10 ... 100 °C
PTFE/EPDM (Code 5M)	-10 ... 100 °C
PTFE/PVDF/EPDM (Code 71)	-10 ... 100 °C

#### Sterilisation temperature <sup>(1)</sup>

FKM (Code 4/4A)	not applicable
EPDM (Code 13/3A)	max. 150 °C <sup>(2)</sup> , max. 60 min per cycle
EPDM (Code 17)	max. 150 °C <sup>(2)</sup> , max. 180 min per cycle
EPDM (Code 19)	max. 150 °C <sup>(2)</sup> , max. 180 min per cycle
EPDM (Code 36)	max. 150 °C <sup>(2)</sup> , max. 60 min per cycle
PTFE/EPDM (Code 54)	max. 150 °C <sup>(2)</sup> , no time limit per cycle
PTFE/EPDM (Code 5M)	max. 150 °C <sup>(2)</sup> , no time limit per cycle
PTFE/PVDF/EPDM (Code 71)	not applicable

<sup>1</sup> The sterilisation temperature is valid for steam (saturated steam) or superheated water.

<sup>2</sup> If the sterilisation temperatures listed above are applied to the EPDM diaphragms for longer periods of time, the service life of the diaphragms will be reduced. In these cases, maintenance cycles must be adapted accordingly. This also applies to PTFE diaphragms exposed to high temperature fluctuations.

PTFE diaphragms can also be used as moisture barriers; however, this will reduce their service life. The maintenance cycles must be adapted accordingly.

GEMÜ 555 and 505 globe valves are particularly suitable for use in the area of steam generation and distribution.

The following valve arrangement for interfaces between steam pipes and process pipes has proven itself over time: A globe valve for shutting off steam pipes and a diaphragm valve as an interface to the process pipes.

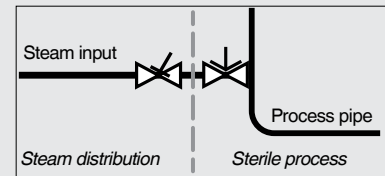

### Ambient temperature

0 ... 60 °C

### Operating pressure [bar]

Type	Diaphragm size	Nominal size	Operating pressure [bar]		
			EPDM / FKM All valve body materials	PTFE Forged body	PTFE Investment cast or cast iron body
GEMÜ 601/602	8	DN 4 - 15	0 - 10	0 - 10	0 - 6
GEMÜ 612	10	DN 10 - 20	0 - 10	0 - 10	0 - 6
GEMÜ 673	25	DN 15 - 25	0 - 10	0 - 10	0 - 6
	40	DN 32 - 40	0 - 10	0 - 10	0 - 6
	50	DN 50 - 65	0 - 10	0 - 10	0 - 6

All pressures are gauge pressures. Operating pressure values were determined with static operating pressure applied on one side of a closed valve. Sealing at the valve seat and atmospheric sealing is ensured for the given values. Information on operating pressures applied on both sides and for high purity media on request.

## Technical data

### Kv values [m<sup>3</sup>/h]

	Pipe standard		DIN	EN 10357 series B (formerly DIN 11850 series 1)	EN 10357 series A (formerly DIN 11850 series 2) / DIN 11866 series A	DIN 11850 Series 3	SMS 3008	ASME BPE / DIN 11866 series C	ISO 1127 / EN 10357 series C / DIN 11866 series B	DIN ISO 228
	Connection code		0	16	17	18	37	59	60	1
Type	MG	DN								
GEMÜ 601/602	8	4	0.5	-	-	-	-	-	-	-
		6	-	-	1.1	-	-	-	1.2	-
		8	-	-	1.3	-	-	0.6	2.2	1.4
		10	-	2.1	2.1	2.1	-	1.3	-	-
		15	-	-	-	-	-	2.0	-	-
GEMÜ 612	10	10	-	2.4	2.4	2.4	-	2.2	3.3	-
		12	-	-	-	-	-	-	-	3.2
		15	3.3	3.8	3.8	3.8	-	2.2	4.0	3.4
		20	-	-	-	-	-	3.8	-	-
GEMÜ 673	25	15	4.1	4.7	4.7	4.7	-	-	7.4	6.5
		20	6.3	7.0	7.0	7.0	-	4.4	13.2	10.0
		25	13.9	15.0	15.0	15.0	12.6	12.2	16.2	14.0
	40	32	25.3	27.0	27.0	27.0	26.2	-	30.0	26.0
		40	29.3	30.9	30.9	30.9	30.2	29.5	32.8	33.0
	50	50	46.5	48.4	48.4	48.4	51.7	50.6	55.2	60.0
65		-	-	-	-	62.2	61.8	-	-	

MG = diaphragm size

Kv values determined acc. to DIN EN 60534, inlet pressure 5 bar,  $\Delta p$  1 bar, stainless steel valve body (forged body) and soft elastomer diaphragm. The Kv values for other product configurations (e.g. other diaphragm or body materials) may differ. In general, all diaphragms are subject to the influences of pressure, temperature, the process and their tightening torques. Therefore the Kv values may exceed the tolerance limits of the standard.

The Kv value curve (Kv value dependent on valve stroke) can vary depending on the diaphragm material and duration of use.

## Order data

Valve type	Code
GEMÜ 601 diaphragm size 8	601
GEMÜ 602 diaphragm size 8 stainless st. handwheel	602
GEMÜ 612 diaphragm size 10	612
GEMÜ 673 diaphragm size 25 - 50	673

Body configuration	Code
Tank valve body	B**
2/2-way body	D
T body	T*
* For dimensions see T Valves brochure	
** Dimensions and versions on request	

Connection	Code
<b>Butt weld spigots</b>	
Spigots DIN	0
Spigots EN 10357 series B (formerly DIN 11850 series 1)	16
Spigot EN 10357 series A (formerly DIN 11850 series 2) / DIN 11866 series A	17
Spigots DIN 11850 series 3	18
Spigots JIS-G 3447	35
Spigots JIS-G 3459	36
Spigots SMS 3008	37
Spigots BS 4825 Part 1	55
Spigot ASME BPE / DIN 11866 series C	59
Spigot ISO 1127 / EN 10357 series C / DIN 11866 series B	60
Spigots ANSI/ASME B36.19M Schedule 10s	63
Spigots ANSI/ASME B36.19M Schedule 15s	64
Spigots ANSI/ASME B36.19M Schedule 40s	65
<b>Threaded connections</b>	
Threaded sockets DIN ISO 228	1
Threaded spigots DIN 11851	6
Cone spigot and union nut DIN 11851	6K
Aseptic unions on request	
<b>Flanges</b>	
Flanges EN 1092 / PN16 / form B, length EN 558, series 1, ISO 5752, basic series 1	8
Flanges ANSI Class 150 RF, length MSS SP-88	38
Flanges ANSI Class 125/150 RF, length EN 558, series 1, ISO 5752, basic series 1	39
<b>Clamp connections</b>	
Clamps ASME BPE for pipe ASME BPE, length ASME BPE	80
Clamps DIN 32676 series B for pipe EN ISO 1127, length EN 558, series 7	82
Clamps ASME BPE for pipe ASME BPE, length EN 558, series 7	88
Clamps DIN 32676 series A for pipe DIN 11850, length EN 558, series 7	8A
Clamps SMS 3017 for pipe SMS 3008, length EN 558, series 7	8E
Clamps DIN 32676 series C, length FTF ASME BPE	8P
Clamps DIN 32676 series C, length FTF EN 558 series 7	8T
Aseptic clamps on request	
For overview of available valve bodies see page 15/16	

Valve body material	Code
EN-GJS-400-18-LT (SG iron 40.3) PFA lined	17
EN-GJS-400-18-LT (SG iron 40.3) PP lined	18
1.4435, investment casting	C3
1.4408, investment casting	37
1.4435 (316L), forged body	40
1.4435 (BN2), forged body $\Delta Fe < 0.5\%$	42
1.4539, forged body	F4

Diaphragm material	Code
FKM	4 4A*
EPDM	13 3A*
EPDM	17
EPDM	19
EPDM	36
PTFE/EPDM, one-piece	54
PTFE/EPDM, two-piece	5M**
PTFE/PVDF/EPDM, three-piece	71***
* for diaphragm size 8	
** Code 5M available from diaphragm size 25	
*** Code 71 only available for bodies with PFA lining (code 17)	
Material complies with FDA requirements, except codes 4 and 4A	

Control function	Code
Manually operated	0

Bonnet version	Code
With seal adjuster, black handwheel GEMÜ 601 diaphragm size 8	0TS
With seal adjuster, metal handwheel GEMÜ 602 diaphragm size 8	0TM
With seal adjuster, black handwheel GEMÜ 612 diaphragm size 10	1TS
With seal adjuster, black handwheel GEMÜ 673 diaphragm size 25	2TS
With seal adjuster, black handwheel GEMÜ 673 diaphragm size 40	3TS
With seal adjuster, black handwheel GEMÜ 673 diaphragm size 50	4TS

## Order data

### Internal surface finishes for forged and block material bodies <sup>1</sup>

Readings for Process Contact Surfaces	Mechanically polished <sup>2</sup>		Electropolished	
	Hygienic class DIN 11866	Code	Hygienic class DIN 11866	Code
Ra ≤ 0.80 µm	H3	1502	HE3	1503
Ra ≤ 0.60 µm	-	1507	-	1508
Ra ≤ 0.40 µm	H4	1536	HE4	1537
Ra ≤ 0.25 µm <sup>3</sup>	H5	1527	HE5	1516

Readings for Process Contact Surfaces acc. to ASME BPE 2016 <sup>4</sup>	Mechanically polished <sup>2</sup>		Electropolished	
	ASME BPE Surface Designation	Code	ASME BPE Surface Designation	Code
Ra Max. = 0.76 µm (30 µinch)	SF3	SF3	-	-
Ra Max. = 0.64 µm (25 µinch)	SF2	SF2	SF6	SF6
Ra Max. = 0.51 µm (20 µinch)	SF1	SF1	SF5	SF5
Ra Max. = 0.38 µm (15 µinch)	-	-	SF4	SF4

### Internal surface finishes for investment cast bodies

Readings for Process Contact Surfaces	Mechanically polished <sup>2</sup>	
	Hygienic class DIN 11866	Code
Ra ≤ 6.30 µm	-	1500
Ra ≤ 0.80 µm	H3	1502
Ra ≤ 0.60 µm <sup>5</sup>	-	1507

<sup>1</sup> Surface finishes of customized valve bodies may be limited in special cases.

<sup>2</sup> Or any other finishing method that meets the Ra value (acc. to ASME BPE).

<sup>3</sup> The smallest possible Ra finish for pipe connections with an internal pipe diameter < 6 mm is 0.38 µm.

<sup>4</sup> When using these surfaces, the bodies are marked according to the specifications of ASME BPE.

The surfaces are only available for valve bodies which are made of materials (e.g. GEMÜ material codes 40, 41, F4, 44) and use connections (e.g. GEMÜ connection codes 59, 80, 88) according to ASME BPE.

<sup>5</sup> Not possible for GEMÜ connection code 59, DN 8 and GEMÜ connection code 0, DN 4.

Ra acc. to DIN EN ISO 4288 and ASME B46.1

## Order data

Special function	Code
3-A compliant design	M

Order example	601	8	D	60	C3	54	0	0TS	1500	M
Type	601									
Nominal size		8								
Body configuration (code)			D							
Connection (code)				60						
Valve body material (code)					C3					
Diaphragm material (code)						54				
Control function (code)							0			
Bonnet version (code)								0TS		
Surface finish (code)									1500	
Special function (code)										M

## Dimensions [mm]

### Bonnet dimensions

Type	Diaphragm size	A	Ø B	Weight [kg]
GEMÜ 601	8	58	32	0.10
GEMÜ 602	8	54	32	0.15
GEMÜ 612	10	80	60	0.40
GEMÜ 673	25	102	90	0.70
	40	119	114	1.30
	50	136	140	2.05

### GEMÜ 601 / 602

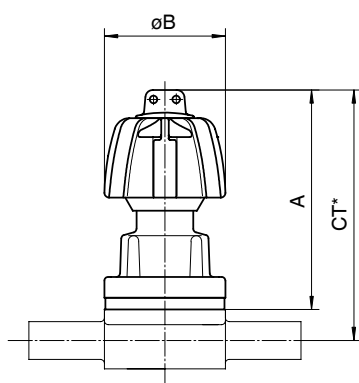

GEMÜ 601

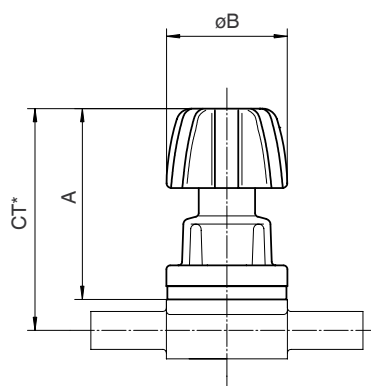

GEMÜ 602

### GEMÜ 612 / 673

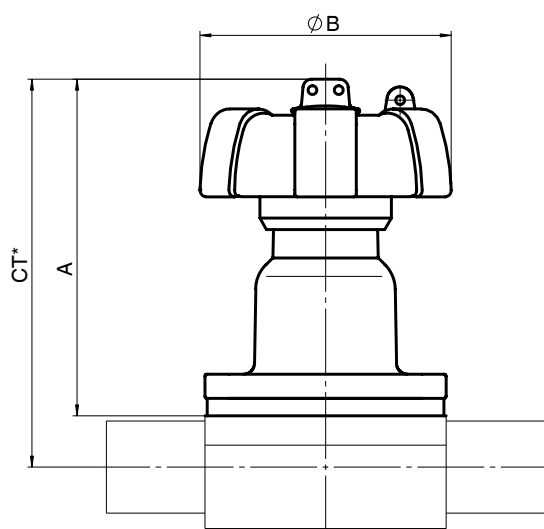

\*  $CT = A + H1$  (see body dimensions)

## Body dimensions [mm]

### Butt weld spigots, connection code 0, 16, 17, 18 Valve body material: Investment casting (code C3), forged body (code 40, F4)

Type	Pipe standard							DIN		EN 10357 series B (formerly DIN 11850 series 1)	EN 10357 series A (formerly DIN 11850 series 2) / DIN 11866 series A	DIN 11850 Series 3		Weight [kg]		
	Connection code							0	16	17	18					
	MG	DN	NPS	L	c	H1*	H1**	ød	s	ød	s	ød	s		ød	s
GEMÜ 601, 602	8	4	-	72	20	8.5		6	1.0	-	-	-	-	-	-	0.09
		6	-	72	20	8.5		-	-	-	-	8	1.0	-	-	0.09
		8	1/4"	72	20	8.5		-	-	-	-	10	1.0	-	-	0.09
		10	3/8"	72	20	8.5		-	-	12	1.0	13	1.5	14	2.0	0.09
GEMÜ 612	10	10	3/8"	108	25	12.5		-	-	12	1.0	13	1.5	14	2.0	0.30
		15	1/2"	108	25	12.5		18	1.5	18	1.0	19	1.5	20	2.0	0.30
GEMÜ 673	25	15	1/2"	120	25	13.0	19.0	18	1.5	18	1.0	19	1.5	20	2.0	0.62
		20	3/4"	120	25	16.0	19.0	22	1.5	22	1.0	23	1.5	24	2.0	0.58
		25	1"	120	25	19.0	19.0	28	1.5	28	1.0	29	1.5	30	2.0	0.55
	40	32	1 1/4"	153	25	24.0	26.0	34	1.5	34	1.0	35	1.5	36	2.0	1.45
		40	1 1/2"	153	25	26.0	26.0	40	1.5	40	1.0	41	1.5	42	2.0	1.32
50	2"	173	30	32.0	32.0	52	1.5	52	1.0	53	1.5	54	2.0	2.25		

\* only for investment cast design      \*\* only for forged design      MG = diaphragm size  
For materials see overview on page 14

### Butt weld spigots, connection code 60 Valve body material: Investment casting (code C3), forged body (code 40, F4)

Type	Pipe standard							ISO 1127 / EN 10357 series C / DIN 11866 series B		Weight [kg]
	Connection code							60		
	MG	DN	NPS	L	c	H1*	H1**	ød	s	
GEMÜ 601, 602	8	6	-	72	20	-	8.5	10.2	1.6	0.09
		8	1/4"	72	20	8.5	8.5	13.5	1.6	0.09
		10	3/8"	72	20	-	8.5	-	-	0.09
GEMÜ 612	10	10	3/8"	108	25	12.5	12.5	17.2	1.6	0.30
		15	1/2"	108	25	12.5	12.5	21.3	1.6	0.30
GEMÜ 673	25	15	1/2"	120	25	13.0	19.0	21.3	1.6	0.62
		20	3/4"	120	25	16.0	19.0	26.9	1.6	0.58
		25	1"	120	25	19.0	19.0	33.7	2.0	0.55
	40	32	1 1/4"	153	25	24.0	26.0	42.4	2.0	1.45
		40	1 1/2"	153	25	26.0	26.0	48.3	2.0	1.32
50	2"	173	30	32.0	32.0	60.3	2.0	2.25		

\* only for investment cast design      \*\* only for forged design      MG = diaphragm size  
For materials see overview on page 14

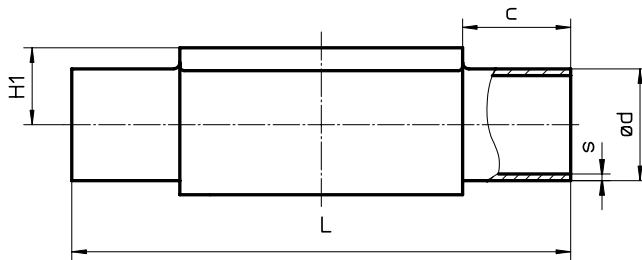



## Body dimensions [mm]

### Butt weld spigots, connection code 35, 36, 37 Valve body material: Investment casting (code C3), forged body (code 40, F4)

Type	Pipe standard							JIS-G 3447		JIS-G 3459		SMS 3008		Weight [kg]
	Connection code							35		36		37		
	MG	DN	NPS	L	c	H1*	H1**	ød	s	ød	s	ød	s	
GEMÜ 601, 602	8	6	-	72	20	-	8.5	-	-	10.5	1.20	-	-	0.09
		8	1/4"	72	20	-	8.5	-	-	13.8	1.65	-	-	0.09
GEMÜ 612	10	10	3/8"	108	25	-	12.5	-	-	17.3	1.65	-	-	0.30
		15	1/2"	108	25	-	12.5	-	-	21.7	2.10	-	-	0.30
GEMÜ 673	25	15	1/2"	120	25	-	19.0	-	-	21.7	2.10	-	-	0.62
		20	3/4"	120	25	-	19.0	-	-	27.2	2.10	-	-	0.58
		25	1"	120	25	19.0	19.0	25.4	1.2	34.0	2.80	25.0	1.2	0.55
	40	32	1 1/4"	153	25	-	26.0	31.8	1.2	42.7	2.80	33.7	1.2	1.45
		40	1 1/2"	153	25	26.0	26.0	38.1	1.2	48.6	2.80	38.0	1.2	1.32
	50	50	2"	173	30	32.0	32.0	50.8	1.5	60.5	2.80	51.0	1.2	2.25
65		2 1/2"	173	30	-	34.0	63.5	2.0	-	-	63.5	1.6	2.20	

\* only for investment cast design      \*\* only for forged design      MG = diaphragm size  
For materials see overview on page 14

### Butt weld spigots, connection code 55, 59, 63, 64, 65 Valve body material: Investment casting (code C3), forged body (code 40, F4)

Type	Pipe standard							BS 4825 Part 1	ASME BPE / DIN 11866 series C		ANSI/ASME B36.19M Schedule 10s		ANSI/ASME B36.19M Schedule 5s		ANSI/ASME B36.19M Schedule 40s		Weight [kg]	
	Connection code							55	59		63		64		65			
	MG	DN	NPS	L	c	H1*	H1**	ød	s	ød	s	ød	s	ød	s	ød		s
GEMÜ 601, 602	8	6	-	72	20	-	8.5	-	-	-	-	10.3	1.24	-	-	10.3	1.73	0.09
		8	1/4"	72	20	8.5	8.5	6.35	1.2	6.35	0.89	13.7	1.65	-	-	13.7	2.24	0.09
		10	3/8"	72	20	8.5	8.5	9.53	1.2	9.53	0.89	-	-	-	-	-	-	0.09
		15	1/2"	72	20	8.5	8.5	12.70	1.2	12.70	1.65	-	-	-	-	-	-	0.09
GEMÜ 612	10	10	3/8"	108	25	-	12.5	9.53	1.2	9.53	0.89	17.1	1.65	-	-	17.1	2.31	0.30
		15	1/2"	108	25	-	12.5	12.70	1.2	12.70	1.65	21.3	2.11	21.3	1.65	21.3	2.77	0.30
		20	3/4"	108	25	12.5	12.5	19.05	1.2	19.05	1.65	-	-	-	-	-	-	0.30
GEMÜ 673	25	15	1/2"	120	25	-	19.0	-	-	-	-	21.3	2.11	21.3	1.65	21.3	2.77	0.62
		20	3/4"	120	25	16.0	19.0	19.05	1.2	19.05	1.65	26.7	2.11	26.7	1.65	26.7	2.87	0.58
		25	1"	120	25	19.0	19.0	-	-	25.40	1.65	33.4	2.77	33.4	1.65	33.4	3.38	0.55
	40	32	1 1/4"	153	25	-	26.0	-	-	-	-	42.2	2.77	42.2	1.65	42.2	3.56	1.45
		40	1 1/2"	153	25	26.0	26.0	-	-	38.10	1.65	48.3	2.77	48.3	1.65	48.3	3.68	1.32
	50	50	2"	173	30	32.0	32.0	-	-	50.80	1.65	60.3	2.77	60.3	1.65	60.3	3.91	2.25
65		2 1/2"	173	30	-	34.0	-	-	63.50	1.65	-	-	-	-	-	-	2.10	

\* only for investment cast design      \*\* only for forged design      MG = diaphragm size  
For materials see overview on page 14

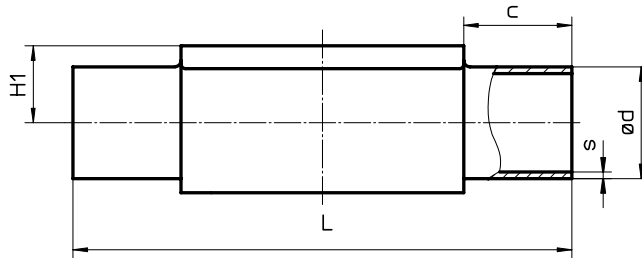

## Body dimensions [mm]

### Threaded sockets, connection code 1 valve body material: investment casting (code 37)

Type	MG	DN	R	H	H1	t	L	SW2	Number of flats	Weight [kg]
GEMÜ 601/602	8	8	G 1/4	19,0	9.0	11	72	18	6	0,09
GEMÜ 612	10	12	G 3/8	25,0	13.0	12	55	22	2	0,17
		15	G 1/2	30,0	15.0	15	68	27	2	0,26
GEMÜ 673	25	15	G 1/2	28,3	14.8	15	85	27	6	0,32
		20	G 3/4	33,3	17.3	16	85	32	6	0,34
		25	G 1	42,3	21.8	13	110	41	6	0,39
	40	32	G 1 1/4	51,3	26.3	20	120	50	8	0,88
		40	G 1 1/2	56,3	28.8	18	140	55	8	0,93
50	50	G 2	71,3	36.3	26	165	70	8	1,56	

MG = Diaphragm size

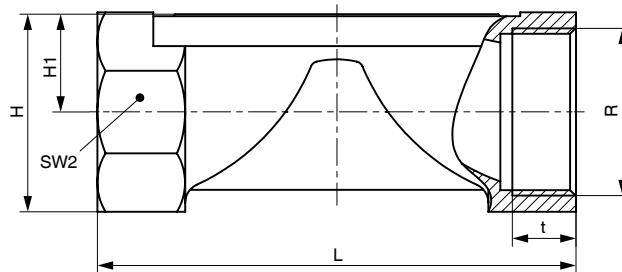

## Body dimensions [mm]

### Threaded connections, connection code 6 Valve body material: Forged body (code 40)

Type	MG	DN	H1	ød1	Thread to DIN 405 R	L	Weight [kg]
GEMÜ 601/602	8	10	8.5	10.0	RD 28 x 1/8	92	0.21
GEMÜ 612	10	10	12.5	10.0	RD 28 x 1/8	118	0.33
		15	12.5	16.0	RD 34 x 1/8	118	0.35
GEMÜ 673	25	15	19.0	16.0	RD 34 x 1/8	118	0.71
		20	19.0	20.0	RD 44 x 1/6	118	0.78
		25	19.0	26.0	RD 52 x 1/6	128	0.79
	40	32	26.0	32.0	RD 58 x 1/6	147	1.66
		40	26.0	38.0	RD 65 x 1/6	160	1.62
		50	50	32.0	50.0	RD 78 x 1/6	191

MG = Diaphragm size

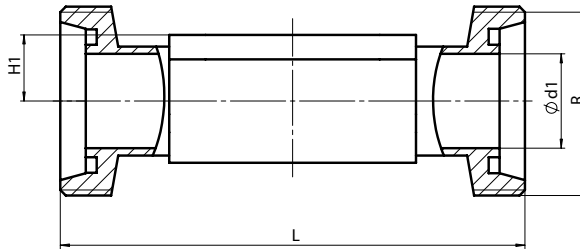

### Cone spigot, connection code 6K Valve body material: Forged body (code 40)

Type	MG	DN	H1	ød1	Thread to DIN 405 R	L	Weight [kg]
GEMÜ 601/602	8	10	8.5	10.0	RD 28 x 1/8	90	0.21
GEMÜ 612	10	10	12.5	10.0	RD 28 x 1/8	116	0.33
		15	12.5	16.0	RD 34 x 1/8	116	0.35
GEMÜ 673	25	15	19.0	16.0	RD 34 x 1/8	116	0.71
		20	19.0	20.0	RD 44 x 1/6	114	0.78
		25	19.0	26.0	RD 52 x 1/6	127	0.79
	40	32	26.0	32.0	RD 58 x 1/6	147	1.66
		40	26.0	38.0	RD 65 x 1/6	160	1.62
		50	50	32.0	50.0	RD 78 x 1/6	191

MG = Diaphragm size

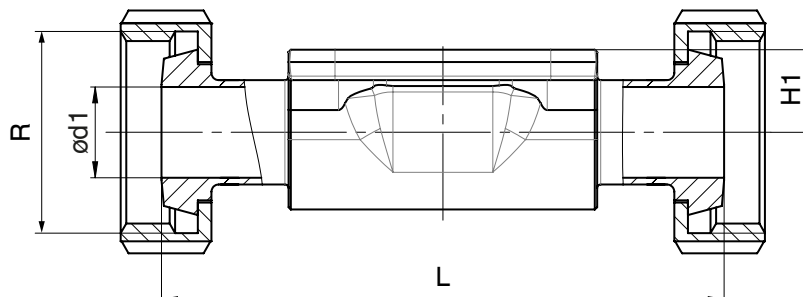

## Body dimensions [mm]

### Flanges - DIN EN 1092, connection code 8 Valve body material GGG 40.3 (code 17, 18), investment casting (code C3), forged body (code 40)

Type	MG	DN	øD	øk	øL	Number of bolts	H1			FTF	Weight [kg]
							Material code 17, 18	Material code C3	Material code 40		
GEMÜ 673	25	15	95	65	14	4	18.0	13.0	19.0	130*	1.85
		20	105	75	14	4	20.5	16.0	19.0	150	2.35
		25	115	85	14	4	23.0	19.0	19.0	160	2.85
	40	32	140	100	19	4	28.7	24.0	26.0	180	4.90
		40	150	110	19	4	33.0	26.0	26.0	200	5.65
		50	165	125	19	4	39.0	32.0	32.0	230	7.45

\*Material code C3, 40 FTF = 150 (no DIN length)

MG = diaphragm size For materials see overview on page 14

### Flanges - ANSI Class 125/150 RF, connection code 38, 39 Valve body material GGG 40.3 (code 17, 18), investment casting (code C3), forged body (code 40)

Type	MG	DN	øD	øk	øL	Number of bolts	H1			FTF		Weight [kg]
							Material code 17, 18	Material code C3	Material code 40	Connection code 38	Connection code 39	
GEMÜ 673	25	15	90	60.3	15.9	4	18.0	13.0	19.0	-	130	1.85
		20	100	69.9	15.9	4	20.5	16.0	19.0	146	150	2.35
		25	110	79.4	15.9	4	23.0	19.0	19.0	146	160	2.85
	40	32	115	88.9	15.9	4	28.7	24.0	26.0	-	180	4.90
		40	125	98.4	15.9	4	33.0	26.0	26.0	175	200	5.65
		50	150	120.7	19.0	4	39.0	32.0	32.0	200	230	7.45

MG = diaphragm size

For materials see overview on page 14

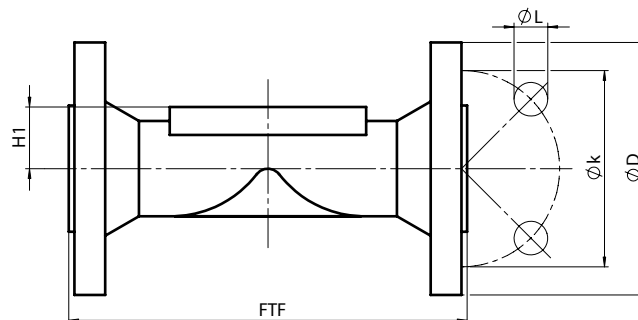

## Body dimensions [mm]

### Clamp connections, connection code 80, 82, 88, 8A, 8E, 8P, 8T Valve body material: Forged body (code 40, F4)

Type	Pipe connection for clamp				ASME BPE						ISO 1127 / EN 10357 series C / DIN 11866 series B			EN 10357 series A (formerly DIN 11850 series 2) / DIN 11866 series A			SMS 3008			Weight [kg]		
	Clamp connection				Code 80, 88 - ASME BPE Code 8P, 8T - DIN 32676 series C						DIN 32676 series B			DIN 32676 series A			ISO 2852 / SMS 3017					
	Clamp connection code				80, 8P			88, 8T			82			8A			8E					
	MG	DN	NPS	H1	ød1	ød3	L	ød1	ød3	L	ød1	ød3	L	ød1	ød3	L	ød1	ød3	L			
GEMÜ 601/602	8	6	1/8"	8.5	-	-	-	-	-	-	7.0	25.0	63.5	6	25.0	63.5	-	-	-	-		
		8	1/4"	8.5	4.57	25.0	63.5	-	-	-	10.3	25.0	63.5	8	25.0	63.5	-	-	-	-	0.15	
		10	3/8"	8.5	7.75	25.0	63.5	-	-	-	-	-	-	-	10	34.0	88.9	-	-	-	-	0.18
		15	1/2"	8.5	9.40	25.0	63.5	9.40	25.0	108	-	-	-	-	-	-	-	-	-	-	-	0.18
GEMÜ 612	10	10	3/8"	12.5	-	-	-	-	-	-	14.0	25.0	108.0	10	34.0	108.0	-	-	-	-	0.30	
		15	1/2"	12.5	9.40	25.0	88.9	9.40	25.0	108	18.1	50.5	108.0	16	34.0	108.0	-	-	-	-	0.43	
		20	3/4"	12.5	15.75	25.0	101.6	15.75	25.0	117	-	-	-	-	-	-	-	-	-	-	-	0.43
GEMÜ 673	25	15	1/2"	19.0	-	-	-	-	-	-	18.1	50.5	108.0	16	34.0	108.0	-	-	-	-	0.75	
		20	3/4"	19.0	15.75	25.0	101.6	15.75	25.0	117	23.7	50.5	117.0	20	34.0	117.0	-	-	-	-	0.71	
		25	1"	19.0	22.10	50.5	114.3	22.10	50.5	127	29.7	50.5	127.0	26	50.5	127.0	22.6	50.5	127	-	0.63	
	40	32	1 1/4"	26.0	-	-	-	-	-	-	38.4	64.0	146.0	32	50.5	146.0	31.3	50.5	146	-	1.62	
		40	1 1/2"	26.0	34.80	50.5	139.7	34.80	50.5	159	44.3	64.0	159.0	38	50.5	159.0	35.6	50.5	159	-	1.50	
	50	50	2"	32.0	47.50	64.0	158.8	47.50	64.0	190	56.3	77.5	190.0	50	64.0	190.0	48.6	64.0	190	-	2.50	
		65	2 1/2"	34.0	60.20	77.5	193.8	60.20	77.5	216	-	-	-	-	-	-	60.3	77.5	216	-	2.30	

MG = diaphragm size

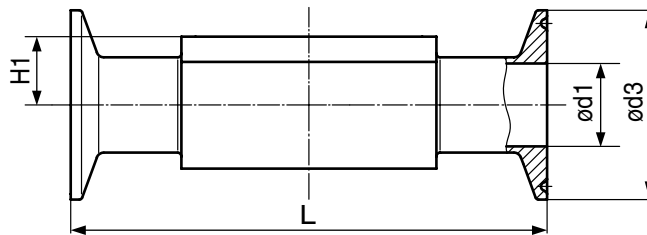

## Overview of valve bodies for GEMÜ 601, 602, 612, 673

Type		Spigots																											
		Connection code		0		16		17		18		35		36		37		55		59		60		63		64		65	
		Material code		C3	40	40	C3	40	40	40	40	40	C3	40	40	40	C3	40	C3	40	C3	40	40	40	40	40	40	40	40
		MG	DN																										
GEMÜ 601/602	8	4	X	X	-	-	-	-	-	-	-	-	-	-	-	-	-	-	-	-	-	-	-	-	-	-	-	-	
		6	-	-	-	X	X	-	-	X	-	-	-	-	-	-	-	-	-	-	-	-	X	X	-	X	-	-	
		8	-	-	-	X	X	-	-	X	-	-	-	-	X	X	X	X	X	X	X	X	X	X	X	X	X	X	X
		10	-	-	X	X	X	X	X	-	-	-	-	-	X	X	X	X	X	X	X	X	X	X	X	X	X	X	X
		15	-	-	-	-	-	-	-	-	-	-	-	-	X	X	X	X	X	X	X	X	X	X	X	X	X	X	X
GEMÜ 612	10	10	-	-	X	X	X	X	X	-	X	-	-	X	-	X	X	X	X	X	X	X	X	X	X	X	X	X	
		15	-	X	X	X	X	X	X	-	X	-	-	X	-	X	X	X	X	X	X	X	X	X	X	X	X	X	X
		20	-	-	-	-	-	-	-	-	-	-	-	-	X	X	X	X	X	X	X	X	X	X	X	X	X	X	X
GEMÜ 673	25	15	-	X	X	X	X	X	X	-	X	-	-	-	-	-	-	X	X	X	X	X	X	X	X	X	X	X	
		20	-	X	X	X	X	X	X	-	X	-	-	X	X	X	X	X	X	X	X	X	X	X	X	X	X	X	X
		25	-	X	X	X	X	X	X	X	X	X	X	-	X	X	X	X	X	X	X	X	X	X	X	X	X	X	X
	40	32	-	X	X	X	X	X	X	X	X	X	-	X	-	-	-	X	X	X	X	X	X	X	X	X	X	X	X
		40	-	X	X	X	X	X	X	X	X	X	-	X	X	X	X	X	X	X	X	X	X	X	X	X	X	X	X
	50	50	-	X	X	X	X	X	X	X	X	X	-	X	X	X	X	X	X	X	X	X	X	X	X	X	X	X	X
65		-	-	-	-	-	-	-	-	X	-	-	-	X	-	-	X	-	-	-	-	-	-	-	-	-	-	-	

Availability of material code 42, F4: same as code 40

MG = diaphragm size

Type		Connection code		Threaded connections		Clamps						Flanges															
				1	6, 6K	80, 8P	82	88, 8T	8A	8E	8				38		39										
				37	40	40	40	40	40	40	17	18	C3	40	17	18	17	18	C3	40							
		MG	DN																								
GEMÜ 601/602	8	6	-	-	-	K	-	K	-	-	-	-	-	-	-	-	-	-	-	-	-	-	-	-	-	-	-
		8	X	-	K	K	-	K	-	-	-	-	-	-	-	-	-	-	-	-	-	-	-	-	-	-	-
		10	-	W	K	-	W	-	-	-	-	-	-	-	-	-	-	-	-	-	-	-	-	-	-	-	-
		15	-	-	K	-	W	-	-	-	-	-	-	-	-	-	-	-	-	-	-	-	-	-	-	-	-
GEMÜ 612	10	10	-	W	-	K	-	K	-	-	-	-	-	-	-	-	-	-	-	-	-	-	-	-	-	-	
		15	X	W	K	W	K	K	-	-	-	-	-	-	-	-	-	-	-	-	-	-	-	-	-	-	
		20	-	-	K	-	K	-	-	-	-	-	-	-	-	-	-	-	-	-	-	-	-	-	-	-	
GEMÜ 673	25	15	X	W	-	W	-	K	-	X	X	W	W	-	-	X	X	W	W	W	W	W	W	W	W	W	
		20	X	W	K	K	K	K	-	X	X	W	W	X	X*	X	X	W	W	W	W	W	W	W	W	W	
		25	X	W	K	K	K	K	K	X	X	W	W	X	X*	X	X	W	W	W	W	W	W	W	W	W	
	40	32	X	W	-	W	-	K	K	X	X	W	W	-	-	X	X	W	W	W	W	W	W	W	W	W	
		40	X	W	K	W	K	K	K	X	X	W	W	X	X*	X	X	W	W	W	W	W	W	W	W	W	
	50	50	X	W	K	W	K	K	K	X	X	W	W	X	X*	X	X	W	W	W	W	W	W	W	W	W	
65		-	-	W	-	W	-	W	-	-	-	-	-	-	-	-	-	-	-	-	-	-	-	-	-		

\* Connection code 38 / material code 18 on request

X = Standard      K = Connections completely machined (not welded)      W = Welded construction

Availability of material code 42, F4: same as code 40

MG = diaphragm size

For further metal diaphragm valves, accessories and other products,  
please see our Product Range catalogue and Price List. Contact GEMÜ.

**GEMÜ** VALVES, MEASUREMENT  
AND CONTROL SYSTEMS

