

**Features**

- 2-channel isolated barrier
- 230 V AC supply
- Dry contact or NAMUR inputs
- Passive transistor output, non-polarized
- Line fault detection (LFD)
- Reversible mode of operation
- Up to SIL 2 acc. to IEC 61508

**Function**

This isolated barrier is used for intrinsic safety applications. It transfers digital signals (NAMUR sensors/mechanical contacts) from a hazardous area to a safe area.

Each proximity sensor or switch controls a passive transistor output for the safe area load. The normal output state can be reversed using switch S1 for channel I and switch S2 for channel II. Switch S3 enables or disables line fault detection of the field circuit.

During an error condition, the transistors revert to their de-energized state and LEDs indicate the fault according to NAMUR NE44.

**Assembly**

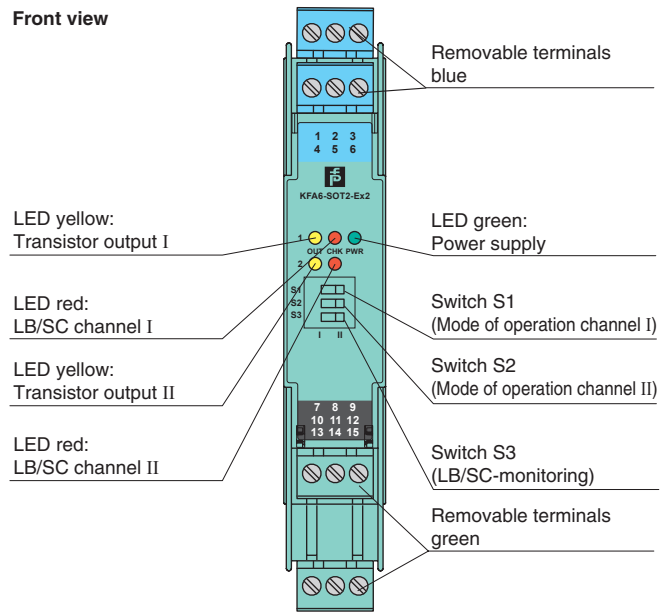

**Connection**

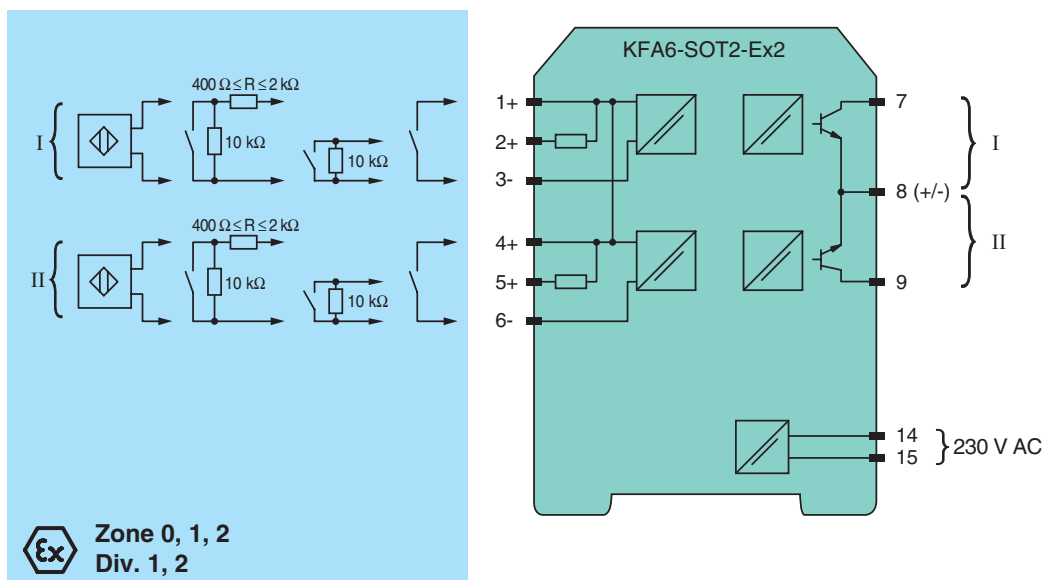

Release date 2017-08-09 14:30 Date of issue 2017-08-09 233753\_eng.xml

Refer to "General Notes Relating to Pepperl+Fuchs Product Information".

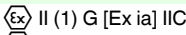
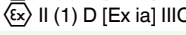
<b>General specifications</b>		
Signal type		Digital Input
<b>Functional safety related parameters</b>		
Safety Integrity Level (SIL)		SIL 2
<b>Supply</b>		
Connection		terminals 14, 15
Rated voltage	$U_r$	207 ... 253 V AC, 45 ... 65 Hz
Power dissipation		1 W
Power consumption		≤ 1.5 W
<b>Input</b>		
Connection side		field side
Connection		terminals 1+, 2+, 3-; 4+, 5+, 6-
Rated values		acc. to EN 60947-5-6 (NAMUR), see system description for electrical data
Open circuit voltage/short-circuit current		approx. 8 V DC / approx. 8 mA
Switching point/switching hysteresis		1.2 ... 2.1 mA / approx. 0.2 mA
Line fault detection		breakage $I \leq 0.1$ mA , short-circuit $I > 6$ mA
<b>Output</b>		
Connection side		control side
Connection		output I: terminals 7, 8 ; output II: terminals 8, 9
Switching voltage		≤ 40 V
Switching current		≤ 100 mA , short-circuit protected
Signal level		1-signal: switching voltage - 2.5 V max. at 10 mA switching current or 3 V max. at 100 mA switching current 0-signal: switched off (off-state current ≤ 10 μA)
Output I, II		signal ; electronic output, passive
<b>Transfer characteristics</b>		
Switching frequency		≤ 5 kHz
<b>Galvanic isolation</b>		
Input/Output		reinforced insulation according to IEC/EN 61010-1, rated insulation voltage 300 V <sub>eff</sub>
Input/power supply		reinforced insulation according to IEC/EN 61010-1, rated insulation voltage 300 V <sub>eff</sub>
Output/power supply		reinforced insulation according to IEC/EN 61010-1, rated insulation voltage 300 V <sub>eff</sub>
Output/Output		not available
<b>Indicators/settings</b>		
Display elements		LEDs
Control elements		DIP-switch
Configuration		via DIP switches
Labeling		space for labeling at the front
<b>Directive conformity</b>		
Electromagnetic compatibility		
Directive 2014/30/EU		EN 61326-1:2013 (industrial locations)
Low voltage		
Directive 2014/35/EU		EN 61010-1:2010
<b>Conformity</b>		
Electromagnetic compatibility		NE 21:2012
Degree of protection		IEC 60529
<b>Ambient conditions</b>		
Ambient temperature		-20 ... 60 °C (-4 ... 140 °F)
<b>Mechanical specifications</b>		
Degree of protection		IP20
Connection		screw terminals
Mass		approx. 150 g
Dimensions		20 x 119 x 115 mm (0.8 x 4.7 x 4.5 inch) , housing type B2
Mounting		on 35 mm DIN mounting rail acc. to EN 60715:2001
<b>Data for application in connection with hazardous areas</b>		
EU-Type Examination Certificate		PTB 98 ATEX 2164
Marking		 
Input		Ex ia IIC, Ex ia IIIC
Voltage	$U_o$	10.5 V
Current	$I_o$	13 mA
Power	$P_o$	34 mW (linear characteristic)
<b>Supply</b>		
Maximum safe voltage	$U_m$	253 V AC (Attention! $U_m$ is no rated voltage.)
<b>Output</b>		
Maximum safe voltage	$U_m$	253 V AC (Attention! The rated voltage can be lower.)

Release date 2017-08-09 14:30 Date of issue 2017-08-09 233753\_eng.xml

<b>Galvanic isolation</b>	
Input/input	not available
Input/Output	safe electrical isolation acc. to IEC/EN 60079-11, voltage peak value 375 V
Input/power supply	safe electrical isolation acc. to IEC/EN 60079-11, voltage peak value 375 V
<b>Directive conformity</b>	
Directive 2014/34/EU	EN 60079-0:2012+A11:2013 , EN 60079-11:2012
<b>International approvals</b>	
UL approval	
Control drawing	116-0145
CSA approval	
Control drawing	116-0047
<b>General information</b>	
Supplementary information	Observe the certificates, declarations of conformity, instruction manuals, and manuals where applicable. For information see <a href="http://www.pepperl-fuchs.com">www.pepperl-fuchs.com</a> .

Release date 2017-08-09 14:30 Date of issue 2017-08-09 233753\_eng.xml

Refer to "General Notes Relating to Pepperl+Fuchs Product Information".

Pepperl+Fuchs Group  
www.pepperl-fuchs.com

USA: +1 330 486 0002  
pa-info@us.pepperl-fuchs.com

Germany: +49 621 776 2222  
pa-info@de.pepperl-fuchs.com

Singapore: +65 6779 9091  
pa-info@sg.pepperl-fuchs.com

**Configuration**

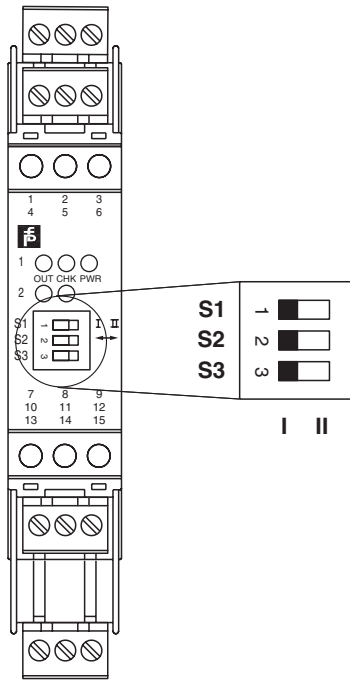

**Switch position**

S	Function		Position
1	Mode of operation Output I active	with high input current	I
		with low input current	II
2	Mode of operation Output II active	with high input current	I
		with low input current	II
3	Line fault detection	ON	I
		OFF	II

**Operating status**

Control circuit	Input signal
Initiator high impedance/ contact opened	low input current
Initiator low impedance/ contact closed	high input current
Lead breakage, lead short-circuit	Line fault

Factory settings: switch 1, 2 and 3 in position I