

TABLE OF CONTENTS



Safety Notices	1
Introduction	3
Testing Samples (Quick Start)	3
Features	3
Keypad Definitions	4
Power Key	4
Up and Down Arrow Keys	4
Enter Key	4
Escape Key	4
Right and Left Arrow Keys	4
Home Key	4
Specifications	5
Installation and Setup	7
Removing Shipping Screws	7
Unit Positioning	7
Power Connection	8
Printing Capabilities	8
Startup	9
Settings	11
Units	12
Selecting a Language	12
LCD Contrast	13
TW Bias Access Code	14
Output Options	14
Selecting Grain	17
Measuring Moisture	19
Preparing To Measure Moisture	19
Loading the Hopper	20
Grain Calibrations	23
Entering New Grain Calibrations	23
Modifying Grain Information	24
Test Weight Bias	24
Issue Number	25
Calibration Values (K1-K9)	26

TABLE OF CONTENTS



Diagnostics	27
Cell Test	27
Null Test, 5KHz, and 2MHz Tests	28
Self Check Test	28
Test Network	29
Temperature	30
Weight	30
Weight Check	31
Weight Table	32
Display Test.....	32
System Information.....	33
System Voltages.....	34
Troubleshooting	35
Shipping and Transportation	35
Cleaning and Care.....	35
Error Codes	36
Replacement Parts	41



SAFETY NOTICES

Safety notices are one of the primary ways to call attention to potential hazards.



This Safety Alert Symbol identifies important safety messages in this manual. When you see this symbol, carefully read the message that follows. Be alert to the possibility of personal injury or death.

⚠ WARNING

Use of the word **WARNING** indicates a potentially hazardous situation which, if not avoided, could result in death or serious injury.

⚠ CAUTION

Use of the word **CAUTION** with the Safety Alert Symbol indicates a potentially hazardous situation which, if not avoided, may result in minor or moderate injury.

CAUTION

Use of the word **CAUTION** without the safety alert symbol indicates a potentially hazardous situation which, if not avoided, may result in equipment damage.

OPERATOR'S MANUAL





INTRODUCTION

The DICKEY-john Grain Analysis Computer GAC[®]500XT quickly tests grain and automatically calculates moisture content, temperature, and approximate test weight (density) of the sample. The unit measures empty cell characteristics, prompts for sample loading, tests the sample, and displays the results. The selected grain name is also displayed during the measurement sequence.

TESTING SAMPLES (QUICK START)

Performing a grain sample analysis consists of six basic steps.

1. Press the MEASURE function using the **Arrow** keys.
2. Press the **Enter** key to initiate a measurement sequence.
3. Follow display instructions to empty the cell.
4. Press the **Enter** key to initiate empty cell measurements. A progress bar will indicate measurement status.
5. Fill the hopper, strike the grain using the grain loader/striker (refer to [Figure 18](#)), and press the **Enter** key to initiate grain measurement. Again, a progress bar will indicate measurement status.
6. Read the test results on the display. Results include moisture, temperature, and test weight.

FEATURES

Major features of the GAC500XT include:

- Memory for up to sixteen grain calibrations
- Keypad entry for updating grain calibration revisions
- Error messages display when moisture, temperature, or weight is out of range
- Keypad entry for new or unique grain measurements
- 12 Vdc mobile adapter
- English/Metric units
- Multiple language groups/dependent upon region
- Audible alarm to signal key depression and measurement culmination
- Print capabilities



Figure 1
GAC500XT Display And Keypad

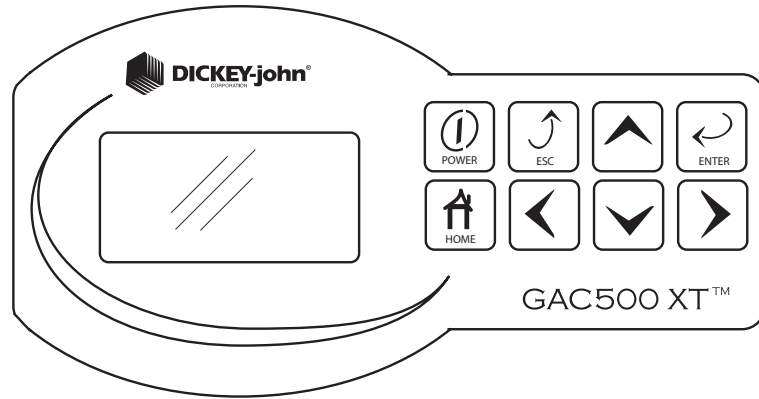

Power key



Up and Down Arrow keys

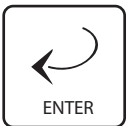

Enter key

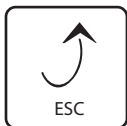

Escape key

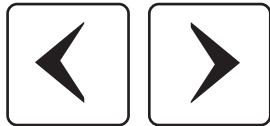

Left and Right Arrow keys



Home key

KEYPAD DEFINITIONS

POWER KEY

Turns the unit ON and OFF.

UP AND DOWN ARROW KEYS

The **Up** and **Down Arrow** keys are used to select menu items, increment/decrement digits, or select characters.

ENTER KEY

The **Enter** key is used to navigate into highlighted functions, initiate actions, or accept data.

ESCAPE KEY

The **Escape (ESC)** key is used to navigate to the previous screen.

RIGHT AND LEFT ARROW KEYS

The **Right** and **Left Arrow** keys are used to select digits or characters.

HOME KEY

The **Home** key is used to return to the **Main** menu.



SPECIFICATIONS

- Supply voltage and frequency
 - wall mount adapter: 90VAC to 264 VAC, 47 to 63 Hz, 0.4A max
 - 6-Volt vehicle adapter: 12-24VDC.
- Operating temperature range: 5°C to 45°C (41°F to 113°F). If the temperature range is exceeded, the unit will measure moisture and display an error message warning the operator that the readings do not necessarily meet unit specifications.
- Grain temperature range: 5°C to 45°C (41°F to 113°F). If the temperature range is exceeded, the unit will measure moisture and display an error message warning the operator that the readings do not necessarily meet unit specifications.
- Unit-grain temperature difference limit: the maximum allowable difference between the empty cell and grain temperature is 20°C (36°F). If the temperature range is exceeded, the unit will measure moisture and display an error message warning the operator that the readings do not necessarily meet unit specifications.
- Classes/types of grain or seed: calibration bulletins may be obtained through the DICKY-john website (www.dickey-john.com) or by requesting a calibration bulletin at:

DICKY-john Corporation
5200 DICKY-john Road
Auburn, Illinois 62615
(800) 637-3302

- Weight: 5.78 kg (13 lbs)
- Shipping weight: 6.35 kg (14 lbs)

NOTE: Before relocating or shipping the GAC500XT, the shipping screws must be replaced.

OPERATOR'S MANUAL





INSTALLATION AND SETUP

Before shipping, the GAC500XT is tested and inspected to ensure the unit is fully operational and meets all measurement specifications. After unpacking, inspect for damage that might have occurred during transit. Save all packing material until inspection is complete. If damage is found, immediately file a claim with the carrier. Also notify your DICKEY-john Sales Representative.

REMOVING SHIPPING SCREWS

Once the GAC500XT is placed in a level location, remove the shipping screws.

CAUTION

Make sure shipping screws are removed prior to operating the GAC500XT. Failure to do so may permanently damage the unit.

Figure 2

Removing Shipping Screws

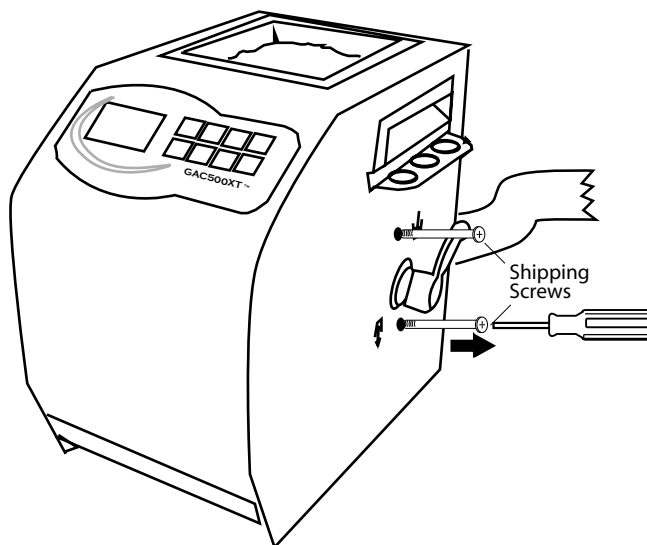

UNIT POSITIONING

To achieve the most precise measurements, select a location that is clean, level, and protected from rapid changes in temperature.



POWER CONNECTION

Using either the AC power adapter or the mobile power adapter, connect the unit on the right rear to the wall outlet or mobile plug, respectively.

Figure 3

Power Connection

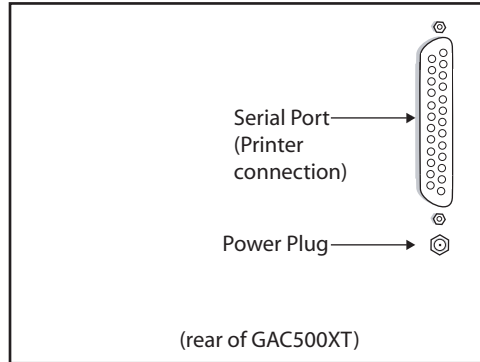

PRINTING CAPABILITIES

The GAC500XT will print to a DICKEY-john Strip Printer PRTS (110v) and PRTSI (220v) in a column format, as illustrated in [Figure 4](#) or any serial printer. For additional printer output information, refer to the SETTINGS section.

Figure 4

Example of GAC500XT Printout

```
DICKEY-JOHN CORP.  
GAC500XT  
  
S/N: 000003  
LINE WHEAT  
910828  
  
MOIST.:  
12.5%  
TW:  
61.5 LB/BU  
TEMP.:  
68.3 F  
=====
```



STARTUP

CAUTION

Before powering the unit, ensure the shipping screws have been removed.

Press the **Power** key to turn on the unit. The **Startup** screen will appear (Figure 5) immediately followed by the Main Menu screen (Figure 6).

Figure 5

Startup Screen



Figure 6

Main Menu Screen

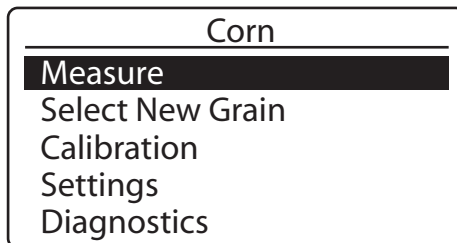





SETTINGS

The GAC500XT settings can be customized to customer preferences by modifying:

- Measurement units
- Language
- LCD contrast
- Access code
- Output options

To change Setting preferences:

1. Highlight **Settings** on the Main screen using the **Up or Down Arrow** keys on the keypad.
2. Press the **Enter** key to access the Settings screen. (Figure 7).

NOTE: ESC key pressed at any time will abort any active operation and return to the screen indicated.

Figure 7

Settings Screen

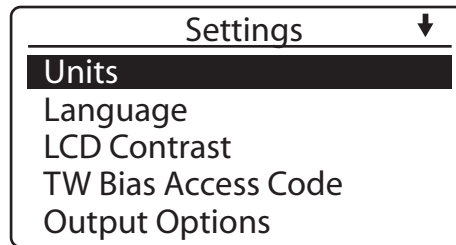

UNITS

To change the Units of Measurement:

1. Highlight UNITS on the Settings screen. using the **Up or Down Arrow** keys.
2. Press the **Enter** key to display the Units screen. The selected unit is indicated with an asterisk (*) next to the label (5.).
3. Use the **Up** and **Down Arrow** keys to navigate to the desired setting.
4. Press **Enter** to change the selection.
5. Press **Enter** again to accept the selection and return to the previous screen.



Figure 8

Units Screen

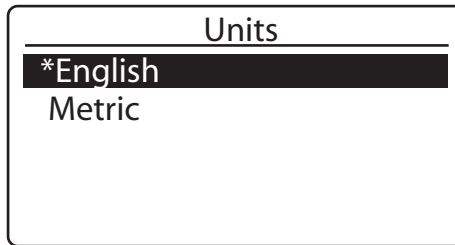

SELECTING A LANGUAGE

To change the Language settings:

1. Highlight LANGUAGE on the **Settings** screen using the **Up or Down Arrow** keys.
2. Press **Enter** to display the Language screen. The selected language is indicated with an asterisk (*) next to the label (Figure 9).
3. Use the **Up** and **Down Arrow** keys to navigate to the desired setting.
4. Press **Enter** to change the selection. The selected language will move to the top of the screen.
5. Press **Enter** again to accept the selection and return to the previous screen.

NOTE: Press the **Home** key at any time, when not in data entry mode, to return to the Main screen.

Figure 9

Language Screen

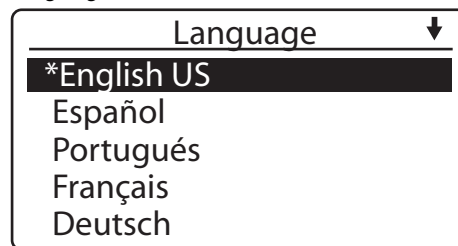

At the top right corner of the **Language** screen, a downward pointing arrow will appear. This indicates that more languages are available for selection by using the **Down Arrow** key. Once the end of the language list is reached, the screen will automatically wrap around to the first language option.

PRINTER SETTINGS

For printer operation, the GAC printer settings should match the settings of the printer. The GAC also supports various languages to output to a printer. The table indicates the character set standards that each language conforms to.

IMPORTANT: It is important to verify that the printer also supports the same standard as the language indicated below to print information correctly.



LANGUAGE	STANDARD USED
English, French, German, Italian Portuguese, Swedish, Finnish, Spanish	ISO 8859-1
Czech/Slovak, Polish, Serbian/ Croatian, Hungarian	ISO 8859-2
Greek	ISO 8859-7
Turkey	ISO 8859-9
Romanian	ISO 8859-16
Russian, Bulgarian	Windows 1251

NOTE: ESC key pressed at any time will abort any active operation and return to the screen indicated.

The GAC default output from the printer port (Figure 3) is RS-232 serial format, 1200 baud, 8 data bits, no parity, and 1 stop bit.

Printer Setting Options:

Baud Rate: 1200, 2400, 4800, 9600, 19200

of Data Bits: 7, 8

Stop Bits: 1, 2

Parity: N (None), O (Odd), E (Even)

To change Printer Settings:

1. Highlight PRINTER SETTINGS on the **Settings** screen, using the **Up or Down Arrow** keys.
2. Press the **Enter** key to display the Printer Settings screen (Figure 10).
3. Use the **Up and Down Arrow** keys to scroll to each line item. Use the **Left and Right Arrow** keys to change to the desired setting.
4. Press the **Enter** key to accept the changes and return to the previous screen.

Figure 10

Printer Settings screen

Printer Settings	
Baud Rate	1200
# of Data Bits	8
Stop Bits	1
Parity	N



LCD CONTRAST

The LCD Contrast may be adjusted on a scale of 0-25, with 25 being the most intense.

To change the LCD Contrast:

1. Highlight LCD Contrast on the Settings screen, using the **Up or Down Arrow** keys.
2. Press the **Enter** key to display the **LCD Contrast** screen.
3. Use the **Up** and **Down Arrow** keys to change the contrast of the LCD display. The LCD will reflect the changes as the number is altered.
4. Press **Enter** to accept the selection and return to the previous screen.

Figure 11

LCD Contrast Screen

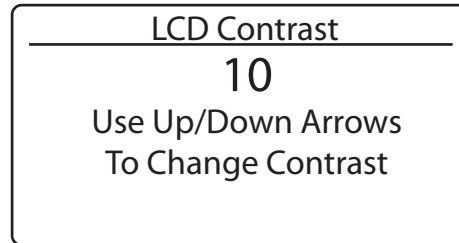

TW BIAS ACCESS CODE

The Test Weight Bias Access Code may be altered from the factory default, which is set to "0000". Creating a new Access Code will ensure that only authorized personnel change the test weight bias. If the changed access code is lost, contact DICKEY-john Technical Support for assistance at 1-800-637-3302.

To change the Test Weight Bias Access Code:

1. Highlight TW BIAS ACCESS CODE on the **Settings** screen, using the **Up or Down Arrow** keys.
2. Press the **Enter** key to display the **Test Weight Bias Access Code** screen ([Figure 12](#)).
3. Use the **Left and Right Arrow** keys to navigate to the appropriate character. The **Up and Down Arrow** keys increase or decrease the number value.
4. Press the **Enter** key to accept the new code and return to the previous screen.

Refer to the GRAIN CALIBRATIONS section for additional information on Test Weight Bias.



Figure 12

Test Weight Bias Access Code Screen



OUTPUT OPTIONS

Output Options determines what information can be printed on the printer ticket.

- Radix point: Can be modified from a period (.) to a comma (,)
- Output Weight, Output Temperature, Output Errors: Selecting YES prints the weight, temperature and errors information on the ticket.
- Print D1-D4: Selecting YES prints values on the ticket.

To change the Output Options:

1. Select OUTPUT OPTIONS on the **Settings** screen.
2. Press the **Enter** key to display the **Output Options** screen (Figure 13).
3. Use the **Up** and **Down Arrow** keys to navigate through the menu. **Left** and **Right Arrow** keys toggle between the settings.
Radix Point can be a period (.) or a comma (,). All other settings are YES (on) or NO (off).
4. Press the **Enter** key to accept the changed values and return to the previous screen.

Figure 13

Output Options Screen

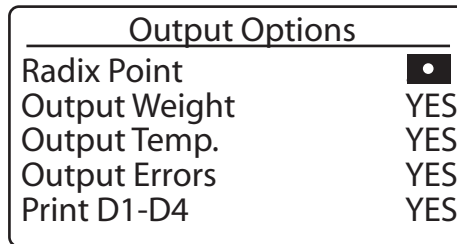





SELECTING GRAIN

To select a new grain:

1. At the Main screen, select the SELECT NEW GRAIN option.
2. Press the **Enter** key to access the **Select Grain** screen (Figure 14). The current grain selection is displayed at the top of the list marked with an asterisk (*).
3. Use the **Up** and **Down Arrow** keys to highlight the desired grain.
4. Choose the desired grain by pressing the **Enter** key. The newly selected grain will display at the top of the list marked with an asterisk. The list is saved in a "last used" order.

NOTE: ESC key pressed at any time will abort any active operation and return to the screen indicated.

Figure 14

Select Grain Screen

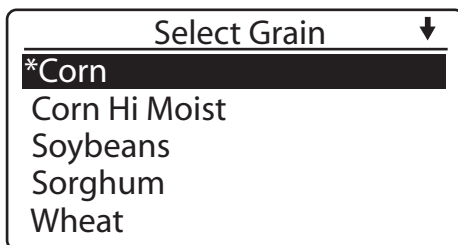

At the top right corner of the **Select Grain** screen, a downward pointing arrow will appear. This indicates that more grains are available for selection than can fit on the screen (16 grains total). The additional grain selections can be accessed by using the **Down Arrow** key. Once the end of the grain list is reached, the screen will automatically wrap around to the first grain option.

If the desired grain is not listed, one of the existing grains may be replaced with another. Refer to the GRAIN CALIBRATIONS section for additional information on entering new grains.





MEASURING MOISTURE

The Main screen appears immediately after all startup self tests have been successfully completed and is the primary screen through which all other screens are accessed.

PREPARING TO MEASURE MOISTURE

1. Confirm the grain selection is correct. The selected grain is displayed on the top of the Main screen (Figure 15). If the grain displayed is correct, continue with LOADING HOPPER. If the grain is incorrect, refer to the SELECTING GRAIN section for instruction. After choosing the proper grain, continue with LOADING HOPPER.

Figure 15

Grain Selection Displayed

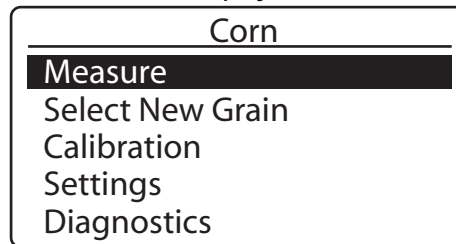

2. Select MEASURE on the Main screen and press the **Enter** key. A message indicating an EMPTY CELL TEST will appear on the display (Figure 16).

NOTE: Too long of a delay between an empty cell test and loading a grain sample will cause an internal time-out. Pressing the Enter key will restart the Empty Cell test.

Figure 16

Empty Cell Test

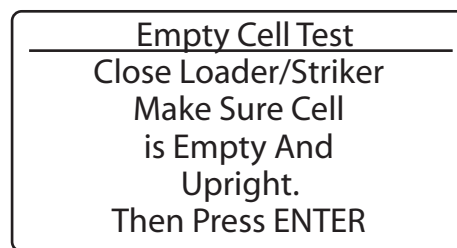

CAUTION

Ensure the GAC500XT is not disturbed during this process. Movement may alter weight measurement, thereby degrading the moisture accuracy.

3. Confirm that the Grain Loader/Striker is in the closed position (fully pushed in) prior to the test. An error message will display if the test is started and the Loader/Striker is not in the closed position.



4. Press the **Enter** key to perform the EMPTY CELL TEST. A progress bar will appear on the screen. Pressing the **Home or Escape** key during the Empty Cell Test will abort the test.
5. Once the test has been performed, the unit will provide steps to load a grain sample (Figure 17).

Figure 17

Load Sample Screen

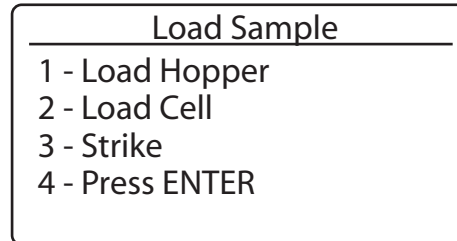

LOADING THE HOPPER

1. Make sure the Cell Dump Lever is in the upper position, enabling the cell to receive grain.
2. Fill the hopper 1/2 inch above the separation line between the top of the hopper and the hopper compartment. Heap the grain slightly.
3. Fill the grain cell by pulling out the Grain Loader/Striker.

IMPORTANT: The Loader/Striker should be pulled to the right in a smooth and reasonably swift stroke. After grain is loaded, return the Loader/Striker to the left. This operation will ensure the cell is completely filled and leveled.

Figure 18

Loading Hopper

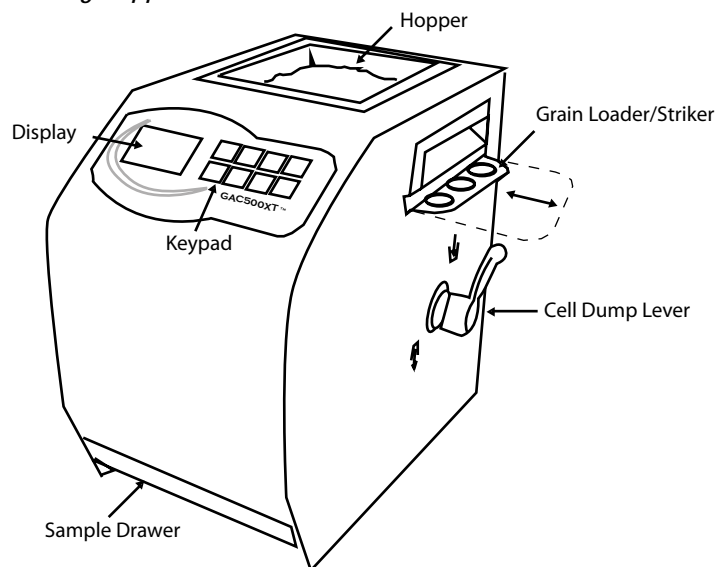



- Once the grain has entered the cell, close the Grain Loader/Striker (push in to close) and press the **Enter** key. A message will appear on the display indicating the measurement is taking place (Figure 19). The status bar will indicate the progress of the grain measurement.

Figure 19

Measurement Window

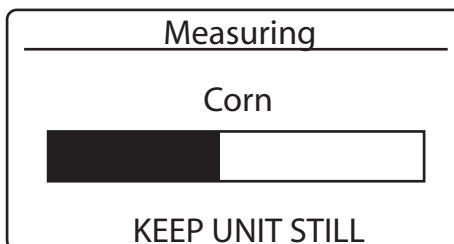

- Once the measurement is complete, the moisture reading will display on the screen (Figure 20).

Figure 20

Moisture Display

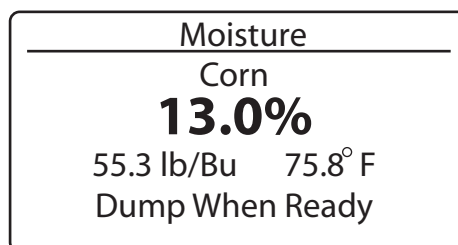

- Dump the sample by rotating the Cell Dump Lever to the bottom (unload) position. Empty the Sample Drawer and the unit is ready to test the next sample.

If an error occurs during a reading, the moisture measurement is a predicted value. If multiple errors occur, use the **Arrow** keys to scroll through the error descriptions.





GRAIN CALIBRATIONS

ENTERING NEW GRAIN CALIBRATIONS

1. Select the CALIBRATION option from the Main screen by using the **Up** or **Down Arrow** keys.
2. Pressing the Enter key will display the **Calibration** screen (Figure 21).

Figure 21

Calibration Screen

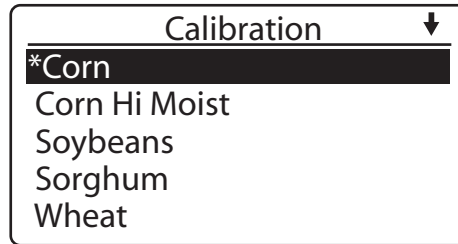

3. The current grain selection will display at the top of the list marked with an asterisk (*).
4. Select a desired grain by pressing the **Enter** key. The specific grain information will display (Figure 22).

NOTE: ESC key pressed at any time will abort any active operation and return to the screen indicated.

Figure 22

Grain Information Screen

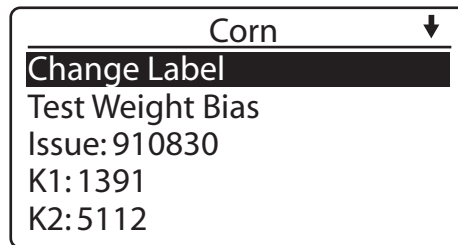

At the top right corner of the Grain Information screen, a downward pointing arrow will appear indicating that more grains are available for selection than can fit on the screen (16 grains total). The additional grain selections may be accessed by using the **Down Arrow** keys. Once the end of the grain list is reached, the screen will automatically wrap around to the first grain option.



MODIFYING GRAIN INFORMATION

Modifications can be made to existing grain information. Information that can be modified includes:

- Grain (Label) Name
- Test Weight Bias
- Issue Number
- Calibration (K1-K9) Values

GRAIN (LABEL) NAMES

To change the Grain Name:

1. Select the CHANGE LABEL option from the **Grain Information** screen.
2. Press the **Enter** key.
3. Highlight the character to be modified by using the **Left** and **Right Arrow** keys ([Figure 23](#)).
4. Use the **Down Arrow** key to move the cursor from the highlighted character to the character selection area. Use the **Left** or **Right Arrow** keys to navigate to the appropriate character and press the **Enter** key to select it. Repeat this process until all desired characters have been updated.
5. Press the **Enter** key once again to accept the changes and return to the previous screen.
6. Press the **Escape (ESC)** key to return to the previous screen.

Figure 23

Modifying Grain Names

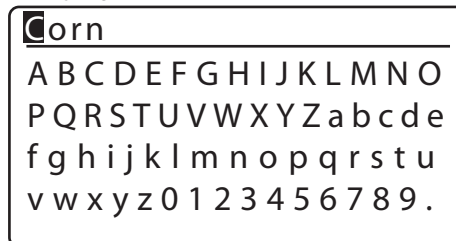

TEST WEIGHT BIAS

The test weight adjustment allows entering of a correction factor for differences between the GAC500XT grain test weight and the official test weight method.

To change the Test Weight Bias:

1. Select the TEST WEIGHT BIAS option from the **Grain Information** screen.
2. Press the **Enter** key.
3. To enter the Access Code, use the **Up** and **Down Arrow** keys to increase/decrease the value of the number and the **Left** and **Right Arrow** keys to navigate to each number.
4. Press **Enter** to select each character. (The ACCESS CODE is set to "0000" as a default unless a new access code was created). Refer to the SETTING sections for creating a new TW Bias Access Code. The Access Code can only consist of numbers with a value from 0000 to 9999.



Figure 24

Entering Access Code

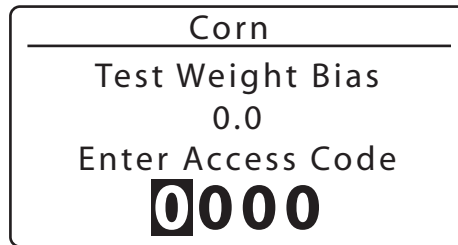

5. Once the ACCESS CODE has been entered, press the **Enter** key again. The **Test Weight Bias** screen will display (Figure 25).
6. Use the **Arrow** keys to enter the appropriate test weight bias. The Test Weight Bias value can vary between -9.9 to 9.9. The default value is 0.0. The **Up** and **Down Arrow** keys will increase/decrease the value of the number. The **Left** and **Right Arrow** keys will navigate through the number.
7. Once the value has been entered, press the **Enter** key to accept the value and return to the previous screen.
8. Press the **Escape** key to return to the previous screen.

NOTE: The first editable location on the Test Weight Bias screen toggles between a space and a "-" sign by using the Up or Down arrow keys.

Figure 25

Test Weight Bias Screen

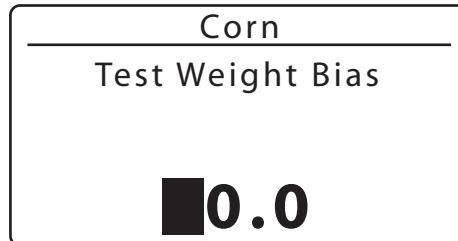

ISSUE NUMBER

An issue number can be modified to update a specific grain calibration or to enter a calibration for a new grain into the GAC. Updating the issues numbers are not required. Refer to the DICKEY-john website for the latest grain calibrations at www.dickey-john.com.

To change the Grain Issue Number:

1. Select the **ISSUE** option from the **Grain Information** screen.
2. Press the **Enter** key and the **Issue Number** screen will appear (Figure 26).
3. Use the **Arrow** keys to navigate to the appropriate character and press the **Enter** key to select it. The last digit scrolls between a space and an "N". (N signifies an NTEP approved calibration which is identified on the grain calibration table).
The **Up** and **Down Arrow** keys will increase/decrease the value of the number. The **Left** and **Right Arrow** keys will navigate through the number. Repeat this process until all desired characters have been updated.



4. Once the desired number has been entered, press the **Enter** key to accept the value and return to the previous screen. Press the **Escape** key to return to the previous screen.

Figure 26

Issue Number Screen

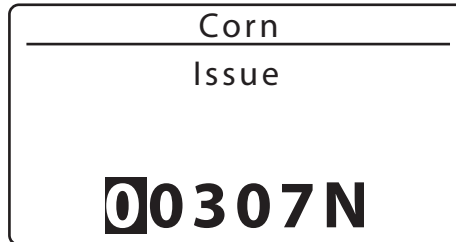

CALIBRATION VALUES (K1-K9)

Calibrations are published on the DICKEY-john website, located at www.dickey-john.com on an annual basis. To maintain current calibration values, these K numbers must be periodically updated.

To change the Calibration Values:

1. Select the appropriate K number to be updated on the **Grain Information** screen.
2. Press the **Enter** key to display the K Number screen ([Figure 27](#)).
3. Use the **Arrow** keys to navigate to the appropriate character and press the **Enter** key to select it. The **Up** and **Down Arrow** keys will increase/decrease the value of the number. The **Left** and **Right Arrow** keys will navigate through the number. Repeat this process until all desired characters have been updated.
4. Once the desired number has been entered, press the **Enter** key to accept the value and return to the previous screen.
5. Press the **Escape** key to return to the previous screen.

Figure 27

K Number Screen

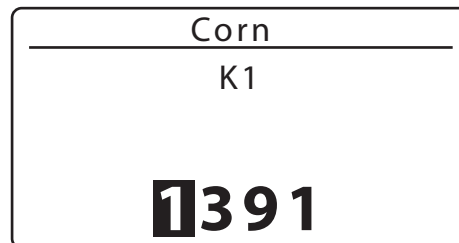



DIAGNOSTICS

Several diagnostic tools are available to verify the unit is operating properly or to provide assistance to technicians during service calls. These include cell tests, temperature, weight, display test, and system information.

To access the Diagnostics screen:

NOTE: Diagnostics screens are view only and are used for troubleshooting purposes. Contact DICKEY-john Technical support for assistance at 1-800-637-3302.

1. Select the DIAGNOSTICS option from the **Main** menu.
2. Press the **Enter** key to display the Diagnostics screen (Figure 28).

Figure 28

Diagnostics Screen

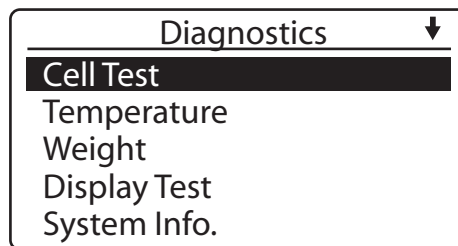

CELL TEST

The Cell Test provides several functions for test and troubleshooting cell measurements. These functions include Null, 5KHz, 2MHz, Self Check, and Test Network. Null, 5KHz, and 2MHz tests provide cell measurements of the primary grain measurement frequencies. Self-check provides SCD1 and SCD2 testing of cell capacitance and conductance measurements. Test network provides additional measurements.

To access the Cell Test screen:

1. Select the CELL TEST option from the **Diagnostics** screen.
2. Press the **Enter** key and the Cell Test screen will display (Figure 29).

*NOTE: Press the **Home** key at any time, when not in data entry mode, to return to the Main screen.*

Figure 29

Cell Test Screen

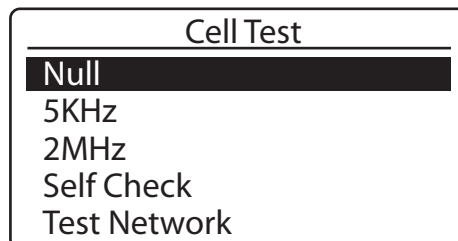



NULL TEST, 5KHZ, AND 2MHZ TESTS

1. Choose the appropriate test and press the **Enter** key. A voltage measurement and count will display ([Figure 30](#)).
2. To return to the **Cell Test** screen, press the **Escape (ESC)** key.

NOTE: Diagnostics screens are view only and are used for troubleshooting purposes. Contact DICKEY-john Technical support for assistance at 1-800-637-3302.

Figure 30

Example Of Null Test

Null	
Count:	01506
Volts:	0.0499

SELF CHECK TEST

During the self check test, ensure the cell is empty. SCD2 and SCD1 measurements will display.

SCD2 should measure 2500 +/- 20 counts.

SCD1 should measure 375 +/- 20 counts.

1. Choose the SELF CHECK option from the **Cell Test** screen.
2. Press the **Enter** key and the self check will automatically begin.
3. The results will display ([Figure 31](#)).
4. To return to the **Cell Test** screen, press the **Escape (ESC)** key.

If measurements are out of range, clean the cell (refer to CLEANING AND CARE) and repeat testing once the cell is cleaned.

If measurements are out of range after cleaning, contact your distributor or DICKEY-john Service Department at 1-800-637-3302. Outside of the U.S., contact DICKEY-john Europe at 00 33 (0) 1 41 19 21 80.

Figure 31

Self Check Screen

Self Check	
SCD2	
2500.3	
SCD1:	377.9



TEST NETWORK

Ensure the cell is empty and in the upright position before performing the network test. Empty cell measurements will be taken. Ambient measurements are required to perform network calculations.

Ensure an empty cell measurement is used prior to performing the D1 and D2 measurement.

To begin Network Test:

NOTE: Minimize the time between empty cell measurement and D1 and D2 measurement to gain the best results.

1. Choose the TEST NETWORK option from the **Cell Test** screen.
2. Press the **Enter** key. The unit will prompt for the cell to be emptied and the **Enter** key to be pressed again (Figure 32).

Figure 32

Test Network Prompt Screen

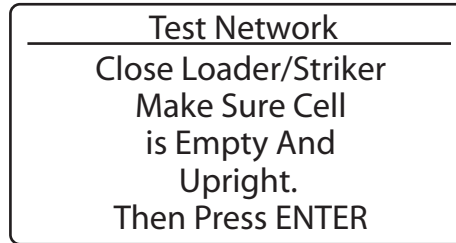

3. Press the **Enter** key to begin the test. A status bar will display (Figure 33), followed by the test results (Figure 34).

Figure 33

Test Network Status Bar

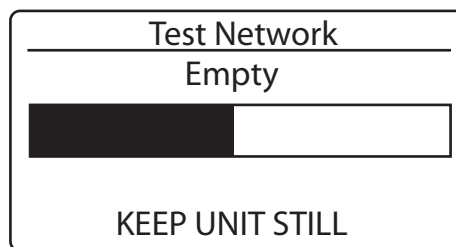
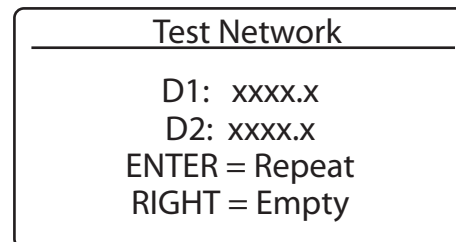

Figure 34

Test Network Results





4. Once empty cell measurements are complete, the display will prompt for either a measurement or to repeat the empty cell test. Press the **Enter** key to measure D1 and D2, or the **Right Arrow** key to repeat empty cell measurements. New values will display once testing is complete.
5. Press the **Escape (ESC)** key to return to the **Cell Test** screen.

TEMPERATURE

The temperature test provides a measurement of cell temperature. The cell can be empty or full for this measurement.

1. Choose the TEMPERATURE option from the **Diagnostics** screen.
2. Press the **Enter** key and the **Temperature** screen will display (**NOTE:**). Allow approximately 6 seconds for the unit to complete averaging measurements. The display will update every 6 seconds with a new measurement.
3. Press the **Escape (ESC)** key to return to the **Diagnostics** screen.

NOTE: Reference Temperature screen displays the reference temperature used to determine the actual temperature.

Figure 35

Temperature Screen

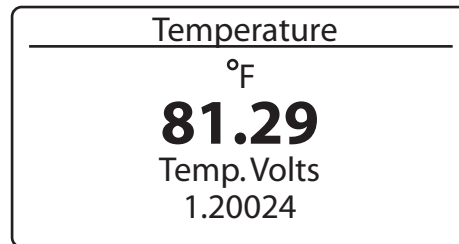

WEIGHT

The Weight feature can be used to measure the weight of the empty cell or the grain currently held inside the cell. An empty cell test should be conducted to verify the empty cell weighs 0.0 grams. Once this has been completed, grain should be loaded into the hopper, then into the cell, and the weight can be checked again. After the weight has been checked, the excess grain in the grain drawer must be discarded, then the cell may be emptied into the grain drawer. The weighed grain can then be taken to a calibrated scale to verify the weight.

To access the **Weight** screen, select the DIAGNOSTICS option from the **Main** menu. Press the **Enter** key to display the Weight screen (**Figure 36**).



Figure 36

Weight Screen

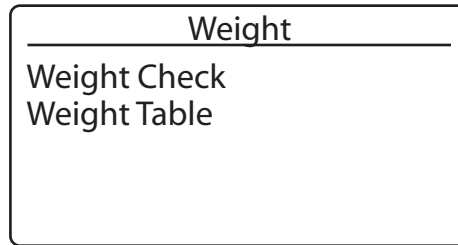

WEIGHT CHECK

To access the Weight Check function:

1. Select the WEIGHT option from the **Diagnostics** screen.
2. Press the **Enter** key and a message will display advising to close the loader/striker and that the cell must be empty (Figure 37).

Figure 37

Weight Verification Screen

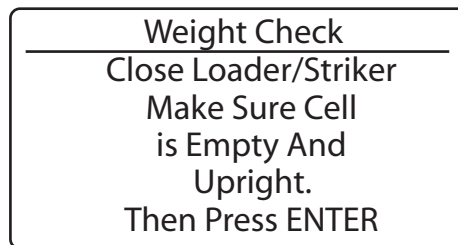

3. Press the **Enter** key. The GAC500XT will weigh the empty cell. A status bar will appear, followed by the results of the weight measurement (Figure 38).

Figure 38

Weight Check Screen - Empty Cell

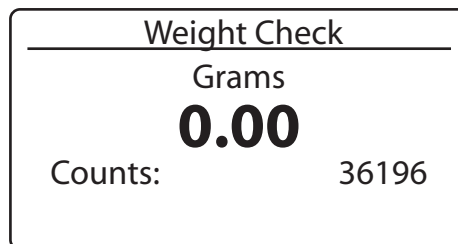

4. Once the measurement displays (results should read 0.00 grams), load grain into the hopper, then the cell, and another measurement can be taken again by pressing the **Enter** key. The process will repeat and a new weight measurement will display (Figure 39).
5. When all readings have been completed, press the **Home** key to return to the Main menu or press the **Escape (ESC)** key twice to return to the **Diagnostics** screen.



Figure 39

Weight Check Screen - Grain Measurement

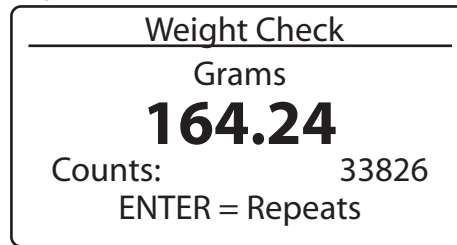

WEIGHT TABLE

The Weight Table is for diagnostic purposes only and is set during factory calibration. This information may be requested for troubleshooting purposes during a service call.

To access the Weight Table:

1. Select the WEIGHT TABLE option from the **Diagnostics** screen.
2. Press Enter to display the Weight Table screen.

Figure 40

Weight Table Screen

Weight Table		↓
Empty	36114	
59.99g	1.02456	
119.94g	1.04924	
180.10g	1.07443	
240.42g	1.09994	

DISPLAY TEST

The display test provides the user with an alternating checkerboard display pattern to detect pixels that remain on or off. Missing pixels will display a light region, while pixels that are stuck on will display a dark region.

To access the **Display Test** screen:

1. Select the DISPLAY TEST option on the **Diagnostics** screen.
2. Press the **Enter** key and the **Display Test** screen will display (Figure 41). The screens will alternate until either the **Escape (ESC)** key or the **Enter** key are pressed.



Figure 41

Display Test Screen

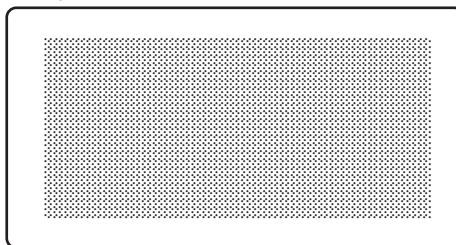

NOTE: ESC key pressed at any time will abort any active operation and return to the screen indicated.

SYSTEM INFORMATION

System information provides the unit's serial number, hardware revision, software version and CAC.

To access the **System Information** screen:

1. Select the SYSTEM INFO option from the **Diagnostics** screen.
2. Press the **Enter** key and the **System Information** screen will display (Figure 42).
3. To exit the screen, select the **Escape (ESC)** key to return to the **Diagnostics** screen, or press the **Home** key to return to the Main screen.

Figure 42

System Information Screen

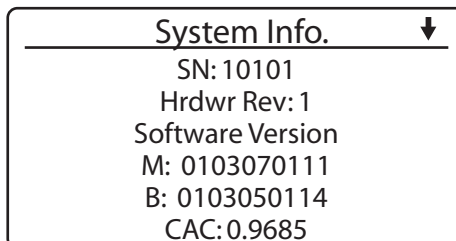



SYSTEM VOLTAGES

System Voltages provides GAC voltages useful for troubleshooting.

To access the **System Voltages** screen:

1. Select the SYSTEM VOLTAGES option from the **Diagnostics** screen.
2. Press the **Enter** key and the **System Voltages** screen will display (Figure 43).
3. To exit the screen, select the **Escape (ESC)** key to return to the **Diagnostics** screen, or press the **Home** key to return to the Main screen.

Figure 43

System Voltages Screen

System Voltages	
Input:	6.11
Display:	3.31
Cell High:	11.94
Cell Low:	-12.25
	37258



TROUBLESHOOTING

SHIPPING AND TRANSPORTATION

The GAC500XT is designed to withstand moderate movement during transportation of the unit. Local transportation from one testing site to another may be accommodated without incident or disruption to the functionality of the unit.

However, care must be taken when transporting the GAC500XT long distances or shipping the unit for service to the DICKEY-john Service Center.

CAUTION

Failure to observe and comply with the following procedures for long distance shipping will result in the voidance of the GAC500XT warranty.

Before shipping the GAC500XT, the following procedures must be followed.

1. Remove the Sample Drawer, invert it, and replace it upside down in the unit. This is required to lift the test cell to the upmost position, aligning the test cell securing hardware inside the unit.
2. Use the shipping screws that were removed during setup and attach to the right side of the unit (refer to [Figure 2](#)). The screws will not align with the test cell securing hardware unless the support cell is lifted to its upmost position by inverting the Sample Drawer.
3. Once the screws are securely in place, remove the Sample Drawer and reinsert to the correct position.

IMPORTANT: Shipping the unit with the sample drawer inverted will damage the test cell. It is imperative that the sample drawer be placed in the correct position before shipping.

CLEANING AND CARE

CAUTION

Ensure unit is disconnected from AC outlet prior to cleaning.

To ensure the most reliable operation of the GAC500XT, clean the cell daily during heavy use or prior to storage. Use the cell brush to clean the inside of the grain cell.

The display, keypad, and enclosure can also be cleaned with window cleaner. Do not spray cleaner into the cell opening or power connector.

Protect the unit from temperature and moisture extremes.

When transporting the unit, invert the sample drawer to protect the measurement cell from vibration and shock damage.



ERROR CODES

The GAC500XT contains a microprocessor to control the grain sample measurements and self-checks to determine the integrity of the internal electronics. If any limit is exceeded or malfunctions occur, an error code will display.

ERROR 1

Probable Cause:

1. The empty cell self check reading is out of limits.

Corrective Action:

1. Dump the cell and ensure it is empty.

ERROR 2

Probable Cause:

1. The empty cell weight reading is out of limits.

Corrective Action:

1. Dump the cell and ensure it is empty.

ERROR 6

Probable Cause:

1. The moisture reading exceeds the upper limit.

Corrective Action:

1. Choose a product within the moisture range and try again.

ERROR 7

Probable Cause:

1. The moisture reading exceeds the lower limit.

Corrective Action:

1. Choose a product within the moisture range and try again.

ERROR 8

Probable Cause:

1. The empty cell ambient temperature has exceeded its limit.

Corrective Action:

1. Allow the GAC500XT to reach normal operating temperature.



ERROR 9

Probable Cause:

1. The sample temperature exceeds its limit.

Corrective Action:

1. Allow the sample to either cool down or warm up, then try again.

ERROR 10

Probable Cause:

1. The difference in temperature between empty cell ambient and full cell condition exceeds its limits.

Corrective Action:

1. Change the appropriate conditions and try again.

ERROR 20

Probable Cause:

1. The unit has detected a software error.

Corrective Action:

1. Contact DICKEY-john Service Department.

ERROR 21

Probable Cause:

1. The measurement cell exceeded low limit.

Corrective Action:

1. Repeat test. If error recurs, contact DICKEY-john Service Department.



ERROR 22

Probable Cause:

1. The measurement cell exceeded high limit.

Corrective Action:

1. Repeat test. If error recurs, contact DICKEY-john Service Department.

ERROR 23

Probable Cause:

1. The measurement cell weight is too low.

Corrective Action:

1. Increase the sample size and repeat the test.

ERROR 24

Probable Cause:

1. The measurement cell weight is too high.

Corrective Action:

1. Repeat the test. Be sure to follow display instructions, ensuring that excess grain has been swept off the cell top.

ERROR 25

Probable Cause:

1. Error was encountered measuring weight.

Corrective Action:

1. Contact DICKEY-john Service Department.

ERROR 26

Probable Cause:

1. VF error is encountered.

Corrective Action:

1. Contact DICKEY-john Service Department.

ERROR 27 - 32

Probable Cause:

1. D1/D2 error is encountered.

Corrective Action:

1. Contact DICKEY-john Service Department.



ERROR 33

Probable Cause:

1. Cell count error is encountered.

Corrective Action:

1. Contact DICKEY-john Service Department.

ERROR 34

Probable Cause:

1. Grain calibration constants entry error.

Corrective Action:

1. Verify and re-enter correct constants.

ERROR 35

Probable Cause:

1. Grain calibration constants entry error.

Corrective Action:

1. Verify and re-enter correct constants.

ERROR 36

Probable Cause:

1. Weight lower than average sample weight tolerance.

Corrective Action:

1. Increase the sample size and repeat the test.

ERROR 37

Probable Cause:

1. Weight higher than average sample weight tolerance.

Corrective Action:

1. Repeat the test. Be sure to follow display instructions, ensuring that excess grain has been swept off cell top.

ERROR 39

Probable Cause:

1. GAC500XT input voltage low.

Corrective Action:

1. Power supply or mobile adapter may be loose or damaged. Verify connection. If problem persists, replace.



ERROR 40

Probable Cause:

1. GAC500XT input voltage is high.

Corrective Action:

1. Replace the power supply or mobile adapter.

ERROR 41

Probable Cause:

1. Display voltage is too low.

Corrective Action:

1. Contact DICKEY-john Service Department.

ERROR 42

Probable Cause:

1. Display voltage is too high.

Corrective Action:

1. Contact DICKEY-john Service Department.

ERROR 43

Probable Cause:

1. Positive cell voltage is too low.

Corrective Action:

1. Contact DICKEY-john Service Department.

ERROR 44

Probable Cause:

1. Positive cell voltage is too high.

Corrective Action:

1. Contact DICKEY-john Service Department.

ERROR 45

Probable Cause:

1. Negative cell voltage is too low.

Corrective Action:

1. Contact DICKEY-john Service Department.



ERROR 46

Probable Cause:

1. Negative cell voltage is too high.

Corrective Action:

1. Contact DICKY-john Service Department.

REPLACEMENT PARTS

Mobile Power Adapter	467950190
Wall Power Adapter	467950150



Dealers have the responsibility of calling to the attention of their customers the following warranty prior to acceptance of an order from their customer for any DICKEY-john product.

DICKEY-john[®] WARRANTY

DICKEY-john warrants to the original purchaser for use that, if any part of the product proves to be defective in material or workmanship within one year from date of original installation, and is returned to DICKEY-john within 30 days after such defect is discovered, DICKEY-john will (at our option) either replace or repair said part. This warranty does not apply to damage resulting from misuse, neglect, accident, or improper installation or maintenance. Said part will not be considered defective if it substantially fulfills the performance expectations. THE FOREGOING WARRANTY IS EXCLUSIVE AND IN LIEU OF ALL OTHER WARRANTIES OF MERCHANTABILITY, FITNESS FOR PURPOSE, AND OF ANY OTHER TYPE, WHETHER EXPRESS OR IMPLIED. DICKEY-john neither assumes nor authorizes anyone to assume for it any other obligation or liability in connection with said part and will not be liable for consequential damages. Purchaser accepts these terms and warranty limitations unless the product is returned within fifteen days for full refund of purchase price.

**For DICKEY-john Service Department,
call 1-800-637-3302 in either the U.S.A. or Canada**



Headquarters:

5200 Dickey-john Road, Auburn, IL 62615
TEL: 217-438-3371, FAX: 217-438-6012, WEB: www.dickey-john.com

Europe:

DICKEY-john Europe S.A., 165, boulevard de Valmy, 92706 - Colombes - France
TEL: 33 (0) 1 41 19 21 80, FAX: 33 (0) 1 47 86 00 07