



Level



Pressure



Flow



Temperature



Liquid
Analysis



Registration



Systems
Components



Services



Solutions

Operating Instructions

Cerabar S PMC71, PMP71, PMP72, PMP75

Process pressure measurement

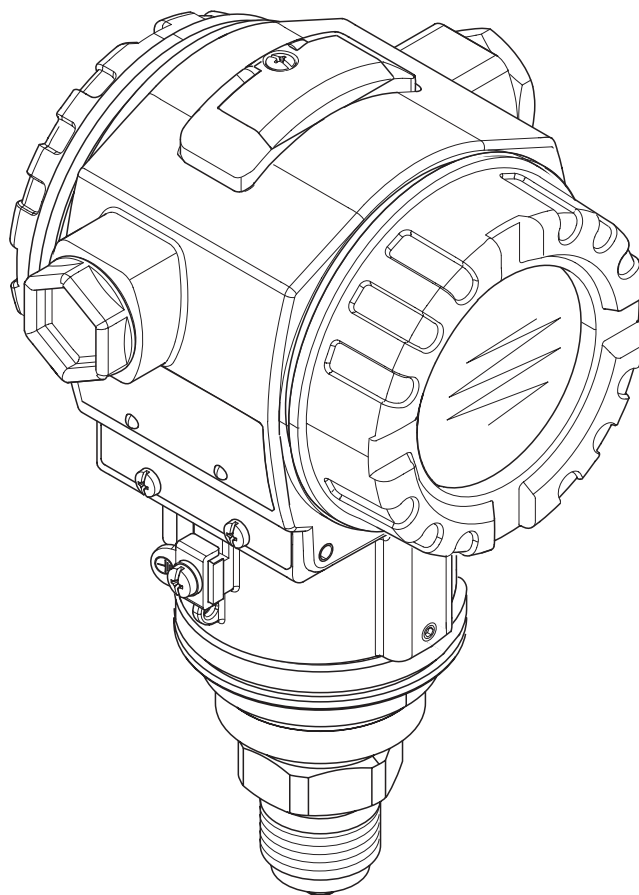

BA271P/00/EN/06.09
71095434

valid from Software version:
02.10.zz

Endress+Hauser

People for Process Automation

Overview documentation

Device	Documentation	Content	Remarks
Cerabar S 4 to 20 mA HART	Technical Information TI383P (PMC71, PMP71, PMP75) Technical Information TI438P (PMP72)	Technical data	<ul style="list-style-type: none"> – The documentation is located on the supplied documentation CD. – The documentation is also available via the Internet. → See: www.endress.com → Download
	Operating Instructions BA271P	<ul style="list-style-type: none"> – Identification – Installation – Wiring – Operation – Commissioning, Description of Quick Setup menus – Maintenance – Trouble-shooting and spare parts – Appendix: Illustration of menu 	
	Operating Instructions BA274P	<ul style="list-style-type: none"> – Examples of configuration for pressure and level measurement – Description of parameters – Trouble-shooting – Appendix: Illustration of menu 	
	Brief Operating Instructions KA1019P	<ul style="list-style-type: none"> – Installation – Wiring – Operation on-site – Commissioning – Description of Quick Setup menus 	
	Brief Operating Instructions KA218P	<ul style="list-style-type: none"> – Wiring – Operation without on-site display – Description of Quick Setup menus – Operation HistoROM®/M-DAT 	
	Functional Safety Manual SD190P	<ul style="list-style-type: none"> – Safety function with Cerabar S – Behaviour in operation and failure – Commissioning and iterative tests – Settings – Technical safety characteristic quantities – Management Summary 	<ul style="list-style-type: none"> – The documentation is valid for devices showing version "E" in feature 100 "Additional options 1" or in feature 110 "Additional options 2". → See also Technical Information TI383P, chapter "Ordering information".

Table of contents

1	Safety instructions	4	8.3	Confirming messages	64
1.1	Designated use	4	8.4	Repair	65
1.2	Installation, commissioning and operation	4	8.5	Repair of Ex-certified devices	65
1.3	Operational safety and process safety	4	8.6	Spare Parts	66
1.4	Notes on safety conventions and icons	5	8.7	Returning the device	67
2	Identification	6	8.8	Disposal	67
2.1	Device designation	6	8.9	Software history	68
2.2	Scope of delivery	9	9	Technical data	70
2.3	CE mark, declaration of conformity	9	10	Appendix	70
2.4	Registered trademarks	9	10.1	Operating menu for on-site display, FieldCare and HART handheld terminal	70
3	Installation	10	10.2	Patents	79
3.1	Incoming acceptance and storage	10	Index		82
3.2	Installation conditions	10			
3.3	Installation instructions	10			
3.4	Post-installation check	19			
4	Wiring	20			
4.1	Connecting the device	20			
4.2	Connecting the measuring unit	22			
4.3	Potential matching	26			
4.4	Overvoltage protection (optional)	27			
4.5	Post-connection check	27			
5	Operation	28			
5.1	On-site display (optional)	28			
5.2	Operating elements	29			
5.3	On-site operation – on-site display not connected	32			
5.4	On-site operation – on-site display connected	35			
5.5	HistoROM®/M-DAT (optional)	37			
5.6	Operation via HART handheld terminal	41			
5.7	FieldCare	41			
5.8	Locking/unlocking operation	42			
5.9	Factory setting (reset)	43			
6	Commissioning	45			
6.1	Function check	45			
6.2	Selecting language and measuring mode	45			
6.3	Position adjustment	47			
6.4	Pressure measurement	48			
6.5	Level measurement	50			
7	Maintenance	54			
7.1	Exterior cleaning	54			
8	Trouble-shooting	55			
8.1	Messages	55			
8.2	Response of outputs to errors	62			

1 Safety instructions

1.1 Designated use

The Cerabar S is a pressure transmitter for measuring pressure and level.

The manufacturer accepts no liability for damages resulting from incorrect use or use other than that designated.

1.2 Installation, commissioning and operation

The device has been designed to operate safely in accordance with current technical, safety and EU standards. If installed incorrectly or used for applications for which it is not intended, however, it is possible that application-related dangers may arise, e.g. product overflow due to incorrect installation or calibration. For this reason, the instrument must be installed, connected, operated and maintained according to the instructions in this manual: personnel must be authorised and suitably qualified. The manual must have been read and understood, and the instructions followed. Modifications and repairs to the device are permissible only when they are expressly approved in the manual. Pay particular attention to the technical data on the nameplate.

1.3 Operational safety and process safety

Alternative monitoring measures must be taken to ensure operational safety and process safety during configuration, testing and maintenance work on the device.

1.3.1 Hazardous areas (optional)

Devices for use in hazardous areas are fitted with an additional nameplate (→ see Page 6). If the device is to be installed in an explosion hazardous area, then the specifications in the certificate as well as all national and local regulations must be observed. The device is accompanied by separate "Ex documentation", which is an integral part of this Operating Instructions. The installation regulations, connection values and Safety Instructions listed in this Ex document must be observed. The documentation number of the related Safety Instructions is also indicated on the additional nameplate.



- Ensure that all personnel are suitably qualified.



1.3.2 Functional Safety SIL3 (optional)





If using devices for applications with safety integrity, the Functional Safety Manual (SD190P) must be observed thoroughly.

1.4 Notes on safety conventions and icons

In order to highlight safety-relevant or alternative operating procedures in the manual, the following conventions have been used, each indicated by a corresponding icon in the margin.

Symbol	Meaning
	Warning! A warning highlights actions or procedures which, if not performed correctly, will lead to personal injury, a safety hazard or destruction of the instrument.
	Caution! Caution highlights actions or procedures which, if not performed correctly, may lead to personal injury or incorrect functioning of the instrument.
	Note! A note highlights actions or procedures which, if not performed correctly, may indirectly affect operation or may lead to an instrument response which is not planned.

	Device certified for use in explosion hazardous area If the device has this symbol embossed on its nameplate, it can be installed in an explosion hazardous area or a non-explosion hazardous area, according to the approval.
	Explosion hazardous area Symbol used in drawings to indicate explosion hazardous areas. – Devices used in hazardous areas must possess an appropriate type of protection.
	Safe area (non-explosion hazardous area) Symbol used in drawings to indicate, if necessary, non-explosion hazardous areas. – Devices used in hazardous areas must possess an appropriate type of protection. Lines used in hazardous areas must meet the necessary safety-related characteristic quantities.

	Direct voltage A terminal to which or from which a direct current or voltage may be applied or supplied.
	Alternating voltage A terminal to which or from which an alternating (sine-wave) current or voltage may be applied or supplied.
	Grounded terminal A grounded terminal, which as far as the operator is concerned, is already grounded by means of an earth grounding system.
	Protective grounding (earth) terminal A terminal which must be connected to earth ground prior to making any other connection to the equipment.
	Equipotential connection (earth bonding) A connection made to the plant grounding system which may be of type e.g. neutral star or equipotential line according to national or company practice.

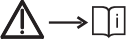
	Safety instruction For safety instructions refer to the manual for the appropriate instrument version.
---	--

2 Identification

2.1 Device designation

2.1.1 Nameplate



Note!

- The MWP (maximum working pressure) is specified on the nameplate. This value refers to a reference temperature of 20°C (68°F) or 100°F for ANSI flanges.
- The pressure values permitted at higher temperatures can be found in the following standards:
 - EN 1092-1: 2001 Tab. 18 ¹⁾
 - ASME B 16.5a – 1998 Tab. 2-2.2 F316
 - ASME B 16.5a – 1998 Tab. 2.3.8 N10276
 - JIS B 2220
- The test pressure corresponds to the over pressure limit (OPL) of the device = MWP x 1.5 ²⁾.
- The Pressure Equipment Directive (EC Directive 97/23/EC) uses the abbreviation "PS". The abbreviation "PS" corresponds to the MWP (maximum working pressure) of the measuring device.

- 1) With regard to their stability-temperature property, the materials 1.4435 and 1.4404 are grouped together under 13EO in EN 1092-1 Tab. 18. The chemical composition of the two materials can be identical.
- 2) The equation does not apply for PMP71 and PMP75 with a 40 bar or a 100 bar measuring cell.

Aluminium and stainless steel housing (T14)

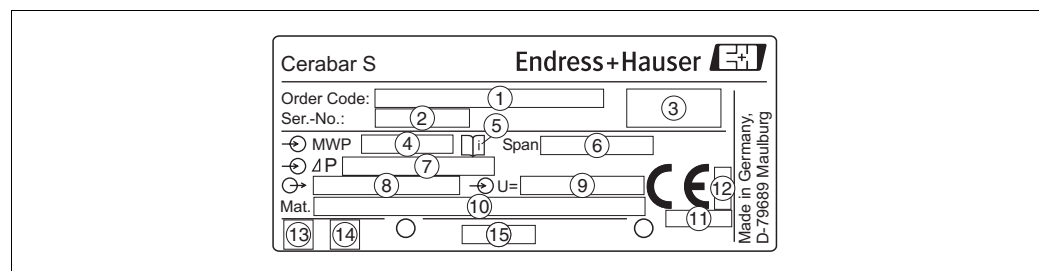

P01-PMx7xxxx-18-xx-xx-xx-001

Fig. 1: Nameplate for Cerabar S

- 1 Order code
See the specifications on the order confirmation for the meanings of the individual letters and digits.
- 2 Serial number
- 3 Degree of protection
- 4 MWP (Maximum working pressure)
- 5 Symbol: Note: pay particular attention to the data in the "Technical Information"!
- 6 Minimum/maximum span
- 7 Nominal measuring range
- 8 Electronic version (output signal)
- 9 Supply voltage
- 10 Wetted materials
- 11 ID number of notified body with regard to Pressure Equipment Directive (optional)
- 12 ID number of notified body with regard to ATEX (optional)
- 13 GL-symbol for GL marine certificate (optional)
- 14 SIL-symbol for devices with SIL3/IEC 61508 Declaration of conformity (optional)
- 15 Layout identification of the nameplate

Devices for use in hazardous areas are fitted with an additional nameplate.

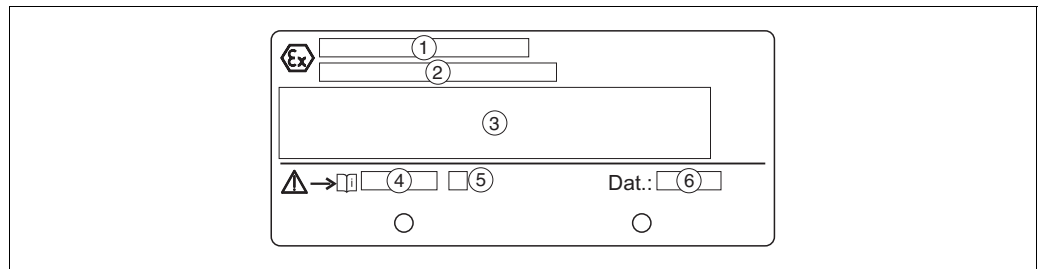

P01-xMD7xxxx-18-xx-xx-xx-002

Fig. 2: Additional nameplate for devices for hazardous areas

- 1 EC type examination certificate number
- 2 Type of protection e.g. II 1/2 G EEx ia IIC T4/T6
- 3 Electrical data
- 4 Safety Instructions number e.g. XA235P
- 5 Safety Instructions index e.g. A
- 6 Device manufacture data

Devices suitable for oxygen applications are fitted with an additional nameplate.

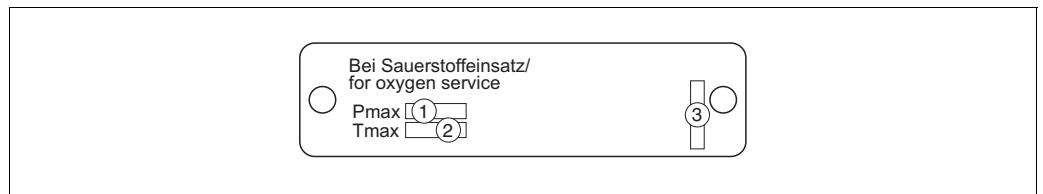

P01-xxxxxxx-18-xx-xx-xx-000

Fig. 3: Additional nameplate for devices suitable for oxygen applications

- 1 Maximum pressure for oxygen applications
- 2 Maximum temperature for oxygen applications
- 3 Layout identification of the nameplate

Hygienic stainless steel housing (T17)

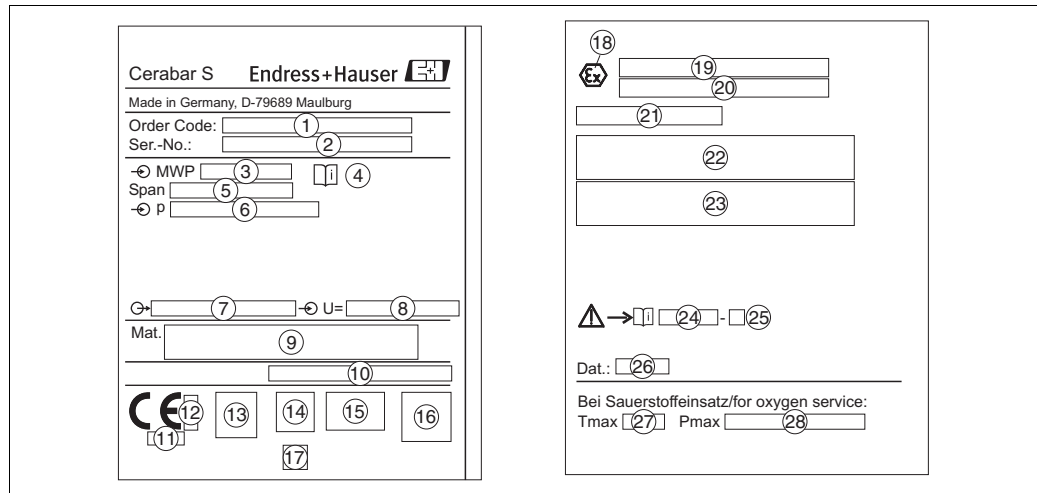

P01-PMx7xxxx-18-xx-xx-xx-003

Fig. 4: Nameplate for Cerabar S

- 1 Order code
See the specifications on the order confirmation for the meanings of the individual letters and digits.
- 2 Serial number
- 3 MWP (Maximum working pressure)
- 4 Symbol: Note: pay particular attention to the data in the "Technical Information"!
- 5 Minimum/Maximum span
- 6 Nominal measuring range
- 7 Electronic version (output signal)
- 8 Supply voltage
- 9 Wetted materials
- 10 Degree of protection

- Optional:
- 11 ID number of notified body with regard to Pressure Equipment Directive
- 12 ID number of notified body with regard to ATEX
- 13 3A-symbol
- 14 CSA-symbol
- 15 FM-symbol
- 16 SIL-symbol for devices with SIL3/IEC 61508 Declaration of conformity
- 17 GL-symbol for GL marine certificate
- 18 Ex-symbol
- 19 EC type examination certificate
- 20 Type of protection e.g. II 1/2 G EEx ia IIC T4/T6
- 21 Approval number for WHG overspill protection
- 22 Temperature operating range for devices for use in hazardous areas
- 23 Electrical data for devices for use in hazardous areas
- 24 Safety Instructions number e.g. XA283P
- 25 Safety Instructions index e.g. A
- 26 Device manufacture data
- 27 Maximum temperature for devices suitable for oxygen applications
- 28 Maximum pressure for devices suitable for oxygen applications

2.2 Scope of delivery

The scope of delivery comprises:

- Cerabar S pressure transmitter
- For devices with the "HistoROM/M-DAT" option:
CD-ROM with Endress+Hauser operating program and documentation
- Optional accessories

Documentation supplied:

- The Operating Instructions BA271P and BA274P, the Technical Information TI383P and the Safety Instructions, Functional Safety Manual and brochures can be found on the supplied documentation CD.
→ See also Page 2, "Overview documentation" chapter.
- Brief Operating Instructions KA1019P
- Leporello KA218P
- Final inspection report
- Also Safety Instructions with ATEX, IECEx and NEPSI devices
- Optional: factory calibration form, test certificates

2.3 CE mark, declaration of conformity

The device is designed to meet state-of-the-art safety requirements, has been tested and left the factory in a condition in which it is safe to operate. The device complies with the applicable standards and regulations as listed in the EC declaration of conformity and thus complies with the statutory requirements of the EC Directives. Endress+Hauser confirms the successful testing of the device by affixing to it the CE mark.

2.4 Registered trademarks

KALREZ, VITON, TEFLON

Registered trademarks of E.I. Du Pont de Nemours & Co., Wilmington, USA

TRI-CLAMP

Registered trademark of Ladish & Co., Inc., Kenosha, USA

HART

Registered trademark of the HART Communication Foundation, Austin, USA.

GORE-TEX®

Registered trademark of W.L. Gore & Associates, Inc., USA

3 Installation

3.1 Incoming acceptance and storage

3.1.1 Incoming acceptance

- Check the packaging and the contents for damage.
- Check the shipment, make sure nothing is missing and that the scope of supply matches your order.

3.1.2 Storage

The device must be stored in a dry, clean area and protected against damage from impact (EN 837-2).

Storage temperature range:

- PMC71, PMP71, PMP75:
 - $-40...+90^{\circ}\text{C}$ ($-40...+194^{\circ}\text{F}$)
 - On-site display: $-40...+85^{\circ}\text{C}$ ($-40...+185^{\circ}\text{F}$)
 - Separate housing: -40 to $+60^{\circ}\text{C}$ (-40 to $+140^{\circ}\text{F}$)
- PMP72:
 - see TI438P

3.2 Installation conditions

3.2.1 Dimensions

→ For dimensions, please refer to the Technical Information for Cerabar S TI383P (PMC71, PMP71, PMP75); TI438P (PMP72), "Mechanical construction" section. See Page 2, "Overview documentation".

3.3 Installation instructions



Note!

- Due to the orientation of the Cerabar S, there may be a shift in the measured value, i.e. when the container is empty, the measured value does not display zero. You may correct this zero point shift either directly on the device using the "E"-key or by remote operation. → See Page 30, Section 5.5.2 "Function of the operating elements – on-site display not connected" or Page 47, Section 6.3 "Position adjustment".
- For PMP75, please refer to Section 3.3.2 "Installation instructions for devices with diaphragm seals – PMP75", Page 13.
- To ensure optimal readability of the on-site display, it is possible to rotate the housing up to 380° . → See Page 19, Section 3.3.5 "Rotating the housing".
- Endress+Hauser offers a mounting bracket for installing on pipes or walls. → See Page 16, Section 3.3.4 "Wall and pipe mounting".

3.3.1 Installation instructions for devices without diaphragm seals – PMP71, PMP72, PMC71



Note!

- If a heated Cerabar S is cooled during the cleaning (e.g. by cold water), a vacuum develops for a short time, whereby water can penetrate the sensor through the pressure compensation (1). If this is the case, mount the sensor with the pressure compensation (1) pointing downwards.

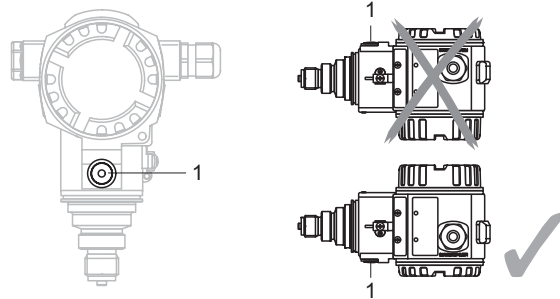

- Keep the pressure compensation and GORE-TEX® filter (1) free from contaminations and water.
- Cerabar S without diaphragm seal are mounted as per the norms for a manometer (DIN EN 837-2). We recommend the use of shut-off devices and siphons. The orientation depends on the measuring application.
- Do not clean or touch process isolating diaphragm seals with hard or pointed objects.

Pressure measurement in gases

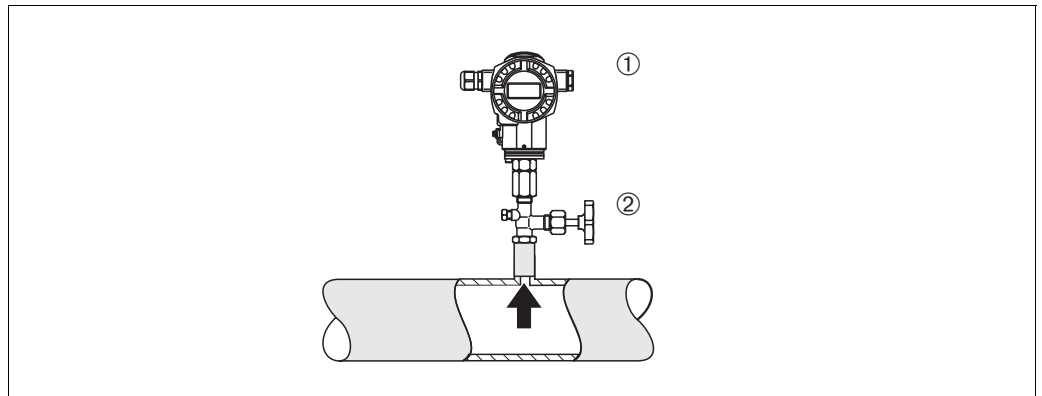
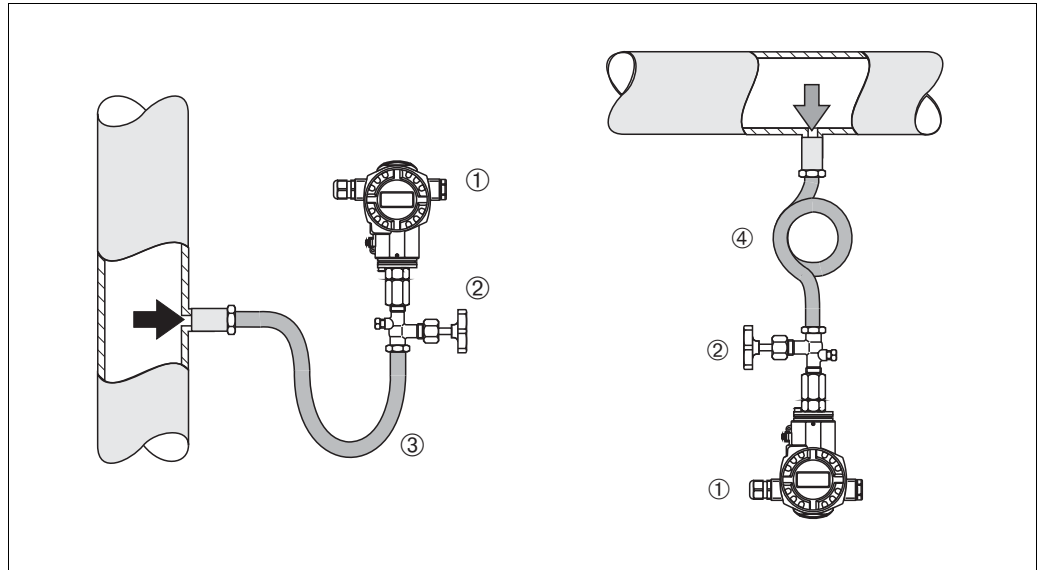

Fig. 5: Measuring arrangement for pressure measurement in gases

- 1 Cerabar S
2 Shut-off device

- Mount Cerabar S with shut-off device above the tapping point so that any condensate can flow into the process.

Pressure measurement in steams



P01-PMx7xxxx-11-xx-xx-xx-002

Fig. 6: Measuring arrangement for pressure measurement in steams

- 1 Cerabar S
- 2 Shut-off device
- 3 U-shaped siphon
- 4 Circular siphon

- Mount Cerabar S with siphon below the tapping point.
The siphon reduces the temperature to almost ambient temperature.
- Fill the siphon with fluid before commissioning.

Pressure measurement in liquids

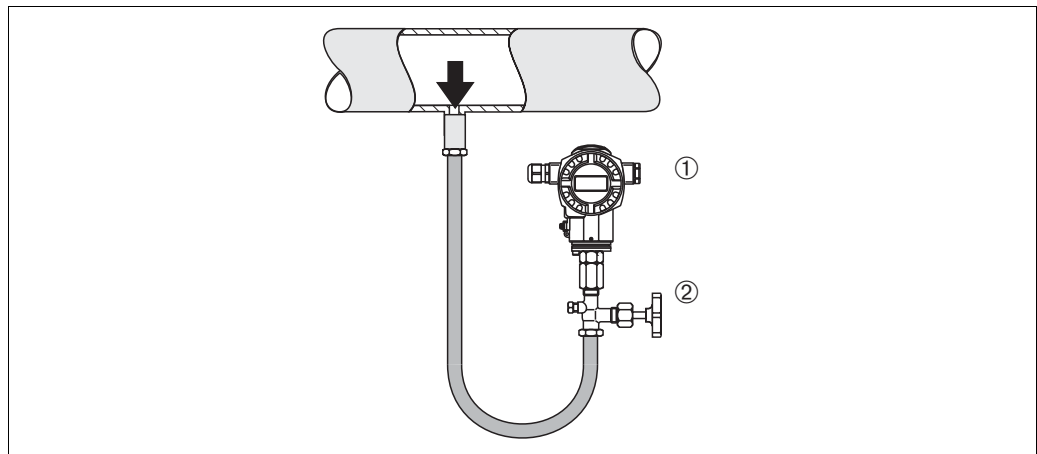

P01-PMx7xxxx-11-xx-xx-xx-003

Fig. 7: Measuring arrangement for pressure measurement in liquids

- 1 Cerabar S
- 2 Shut-off device

- Mount Cerabar S with shut-off device below or at the same level as the tapping point.

Level measurement

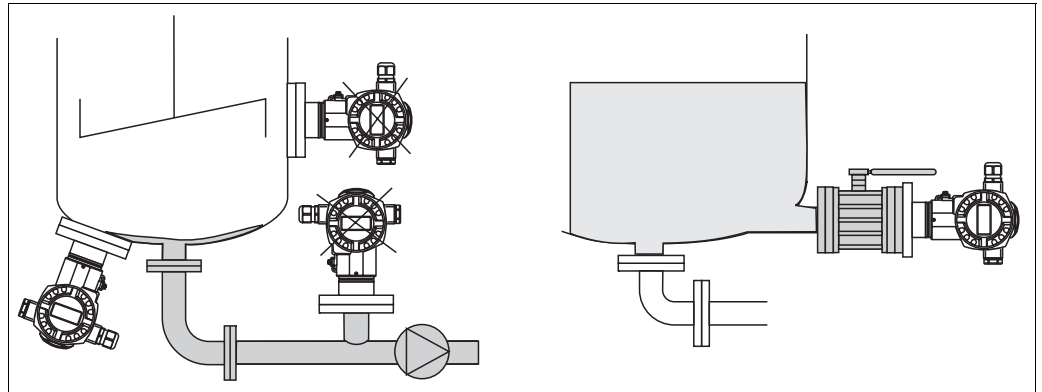

Fig. 8: Measuring arrangement for level

- Mount Cerabar S below the lowest measuring point.
- Do not mount the device at the following positions:
In the fill flow, in the tank outlet or at a point in the container which could be affected by pressure pulses from an agitator.
- Do not mount the device in the suction area of a pump.
- The calibration and functional test can be carried out more easily if you mount the device after a shut-off device.

PVDF adapter



Note!

For instruments with PVDF adapter, a maximum torque of 7 Nm is permitted. The thread connection may become loose at high temperatures and pressures. This means that the integrity of the thread must be checked regularly and may need to be tightened using the torque given above. Teflon tape is recommended for sealing with the 1/2 NPT thread.

3.3.2 Installation instructions for devices with diaphragm seals – PMP75



Note!

- The Cerabar S with diaphragm seal is screwed in, flanged or clamped, depending on the type of diaphragm seal.
- The diaphragm seal and the pressure sensor together form a closed and calibrated system which is filled with filling fluid through a hole in the upper part. This hole is sealed and not to be opened.
- Do not clean or touch process isolating diaphragm of the diaphragm seals with hard or pointed objects.
- Do not remove the protection of the process isolating diaphragm until shortly before installation.
- When using a mounting bracket, sufficient strain relief must be ensured for the capillaries in order to prevent the capillary bending down (bending radius ≥ 100 mm).
- Please note that the hydrostatic pressure of the liquid columns in the capillaries can cause zero point shift. The zero point shift can be corrected. → See also Page 47, Section 6.3 "Position adjustment".
- Please note the application limits of the diaphragm seal filling oil as detailed in the Technical Information for Cerabar S TI383P, Section "Planning instructions for diaphragm seal systems". → See also Page 2, "Overview documentation".

In order to obtain more precise measurement results and to avoid a defect in the device, mount the capillaries as follows:

- vibration-free (in order to avoid additional pressure fluctuations)
- not in the vicinity of heating or cooling lines
- insulate if the ambient temperature is below or above the reference temperature
- with a bending radius of ≥ 100 mm.

Vacuum application

For applications under vacuum, Endress+Hauser recommends mounting the pressure transmitter underneath the diaphragm seal. A vacuum load of the diaphragm seal caused by the presence of filling oil in the capillaries is hereby prevented.

When the pressure transmitter is mounted above the diaphragm seal, the maximum height difference H1 in accordance with the illustration below on the left must not be exceeded. The maximum height difference is dependent on the density of the filling oil and the smallest ever pressure that is permitted to occur at the diaphragm seal (empty container), see illustration below, on the right.

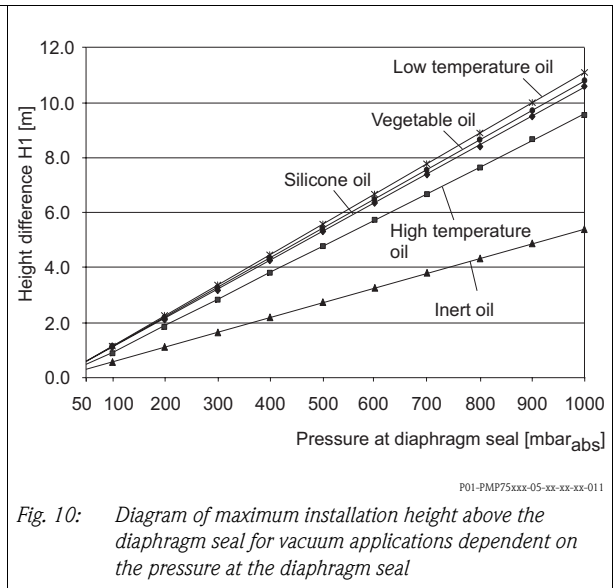
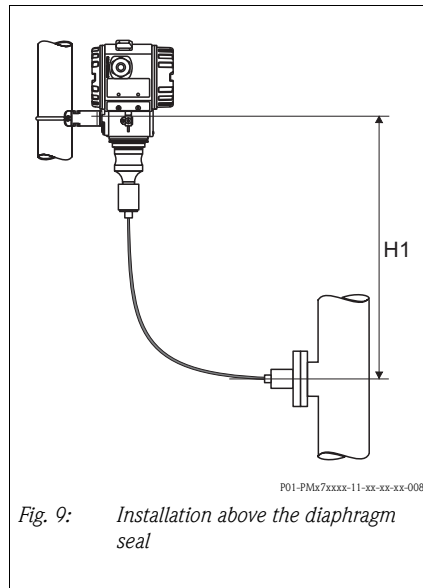

Mounting with temperature isolator

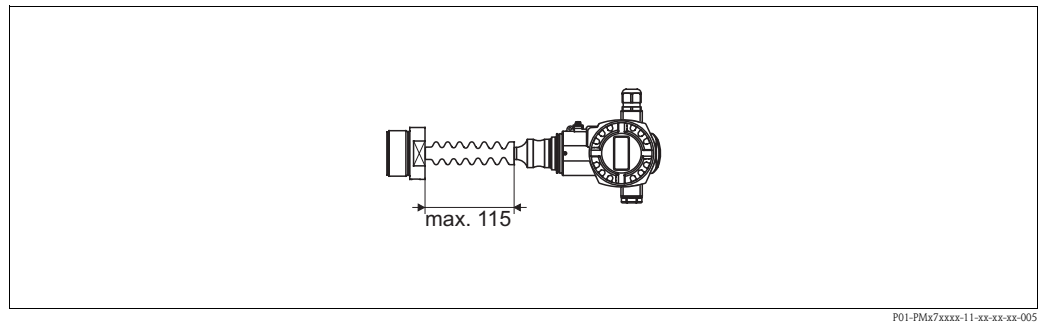

Endress+Hauser recommends the use of temperature separators in the event of constant extreme fluid temperatures which lead to the maximum permissible electronics temperature of +85°C (+185°F) being exceeded. To minimise the influence of rising heat, Endress+Hauser recommends the device be mounted horizontally or with the housing pointing downwards.

The additional installation height also brings about a zero point shift of approx. 21 mbar due to the hydrostatic columns in the temperature isolator. You can correct this zero point shift. → See also Page 30, Section 5.2.2 "Function of the operating elements – on-site display not connected" or Page 47, Section 6.3 "Position adjustment".

3.3.3 Seal for flange mounting

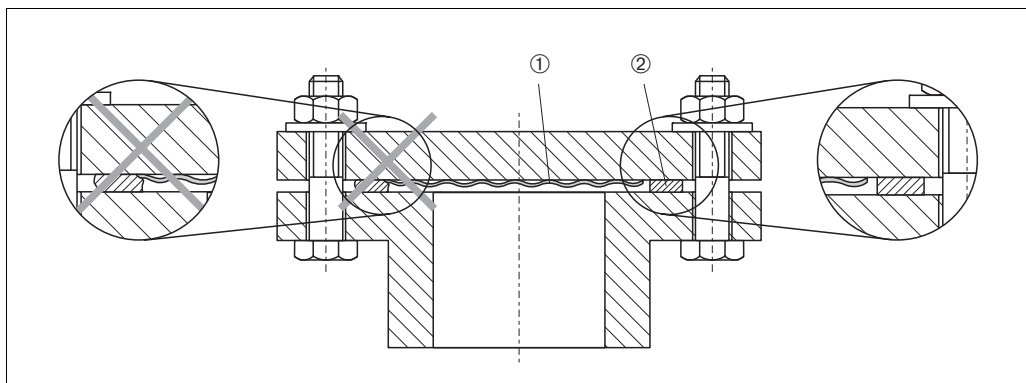

Fig. 11: Mounting the versions with flange or diaphragm seal

- 1 Process isolating diaphragm
- 2 Seal



Warning!

The seal is not allowed to press on the process isolating diaphragm as this could affect the measurement result.

3.3.4 Installation with heat insulation – PMC71 high temperature version and PMP72/PMP75

The devices must only be insulated up to a certain height. The maximum permitted insulation height is labelled on the devices and applies to an insulation material with a specific heat conductivity and to the maximum permitted ambient and process temperature (→ see following table). The data were determined under the most critical application "quiescent air".

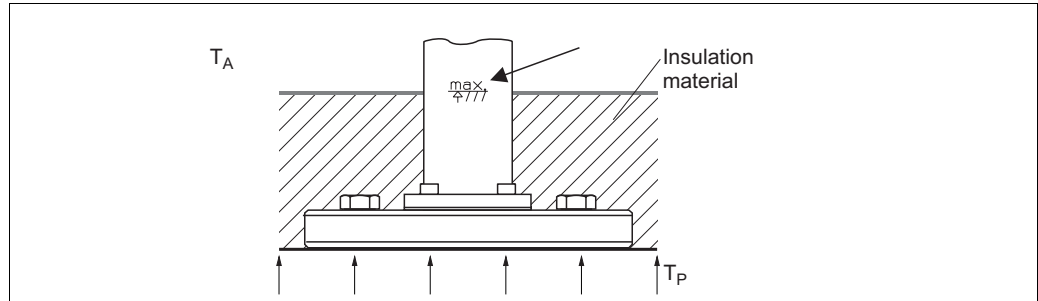

Fig. 12: Maximum insulation height, here e.g. PMC71 with flange

	PMC71	PMP75	PMP72
Ambient temperature (T_A)	$\leq 70^\circ\text{C}$ (158°F)	$\leq 70^\circ\text{C}$ (158°F)	$\leq 50^\circ\text{C}$ (122°F)
Process temperature (T_P)	$\leq 150^\circ\text{C}$ (302°F)	$\leq 400^\circ\text{C}$ (752°F) ¹⁾	$\leq 280^\circ\text{C}$ (536°F)
Heat conductivity Insulation material	$\leq 0,04 \text{ W}/(\text{m} \times \text{K})$		at 100°C (212°F): $\delta 0,04 \text{ W}/(\text{m} \times \text{K})$ at 300°C (572°F): linearly increasing to $0,072 \text{ W}/(\text{m} \times \text{K})$

1) Depending on the diaphragm seal filling oil used (→ see Technical Information TI383P Cerabar S)

3.3.5 Wall and pipe-mounting (optional)

Endress+Hauser offers a mounting bracket for installing on pipes or walls.

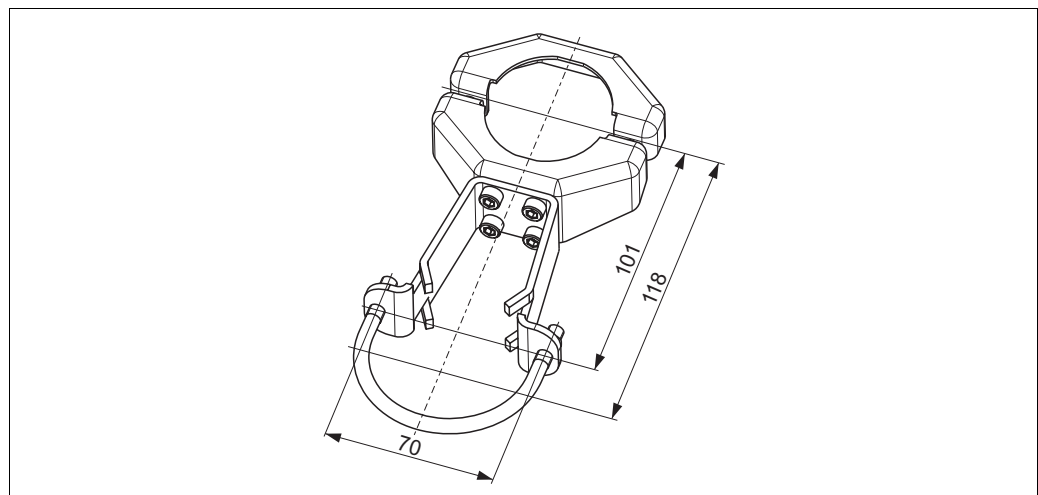

Please note the following when mounting:

- The cable entry should always point downwards so that moisture on the connecting cable can drain off and not penetrate the housing.
- In the case of pipe mounting, the nuts on the bracket must be tightened uniformly with a torque of at least 5 Nm.

3.3.6 Assembling and mounting the "separate housing" version

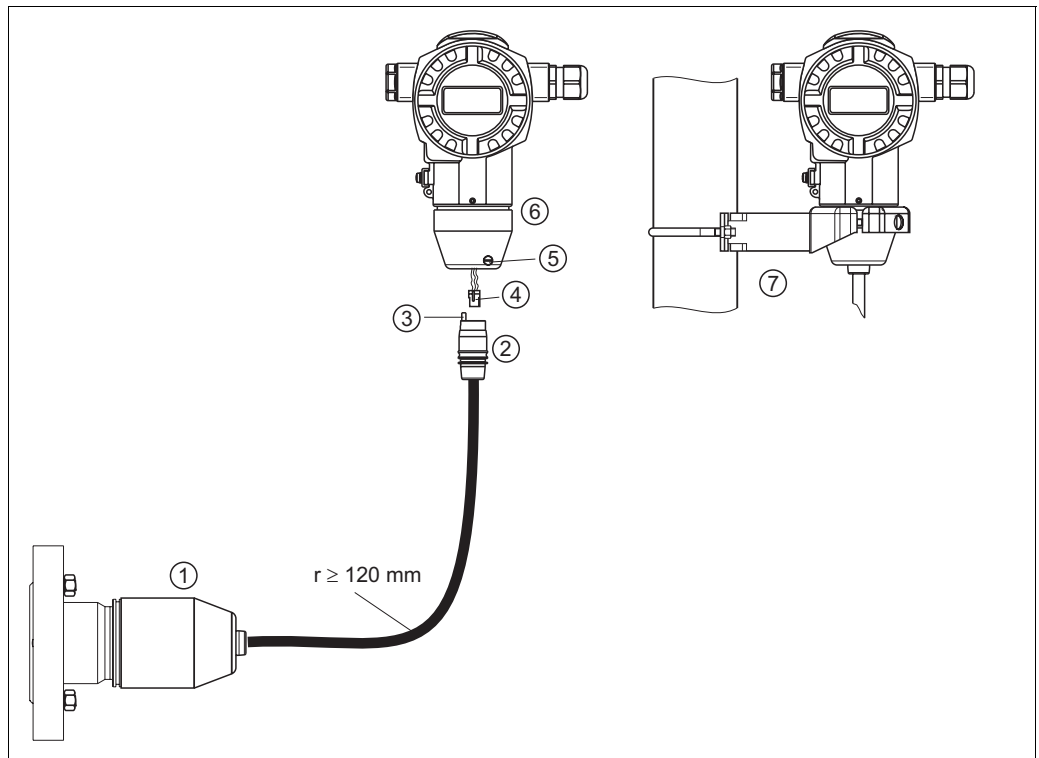

P01-PMx7xxxx-11-xx-xx-xx-011

Fig. 13: "Separate housing" version

- 1 In the "separate housing" version, the sensor is supplied with process connection and cable fitted.
- 2 Cable with connection jack
- 3 Pressure compensation
- 4 Plug
- 5 Locking screw
- 6 Housing fitted with housing adapter, included
- 7 Mounting bracket suitable for wall and pipe mounting, included

Assembly and mounting

1. Connect plug (item 4) into the corresponding connection jack of the cable (item 2).
2. Plug the cable into the housing adapter (item 6).
3. Tighten the locking screw (item 5).
4. Mount the housing on a wall or pipe using the mounting bracket (item 7). When mounting on a pipe, tighten the nuts on the bracket uniformly with a torque of at least 5 Nm. Mount the cable with a bending radius (r) \geq 120 mm.

3.3.7 PMP71, version prepared for diaphragm seal mount – welding recommendation

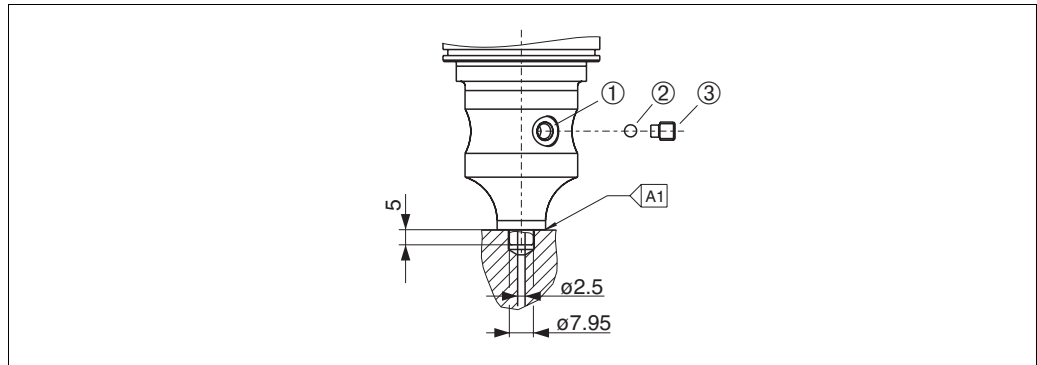

P01-PMP71xxx-11-xx-xx-xx-000

Fig. 14: Version U1: prepared for diaphragm seal mount

- 1 Hole for filling fluid
- 2 Bearing
- 3 Threaded pin with an internal hexagon 4 mm
- A1 see the following table "Welding recommendation"

Welding recommendation

For the "U1 Prepared for diaphragm seal mount" version in feature 70 "Process connection; Material" in the order code of up to including 40 bar-sensors, Endress+Hauser recommends welding on the diaphragm seal as follows: the total welding depth of the fillet weld is 1 mm at an external diameter of 16 mm. Welding is performed according to the WIG method.

Consecutive seam no.	Sketch/welding groove shape, dimension as per DIN 8551	Base material matching	Welding process DIN EN ISO 24063	Welding position	Inert gas, additives
A1 for sensors ≤ 40 bar	<p>P01-PMP71xxx-11-xx-xx-xx-001</p>	Adapter made of 1.4435 (AISI 316L) to be welded to diaphragm seal made of 1.4435 or 1.4404 (AISI 316L)	141	PB	Inert gas Ar/H 95/5 Additive: 1.4430 (ER 316L Si)

3.3.8 Rotating the housing

The housing can be rotated up to 380° by loosening the Allen screw.

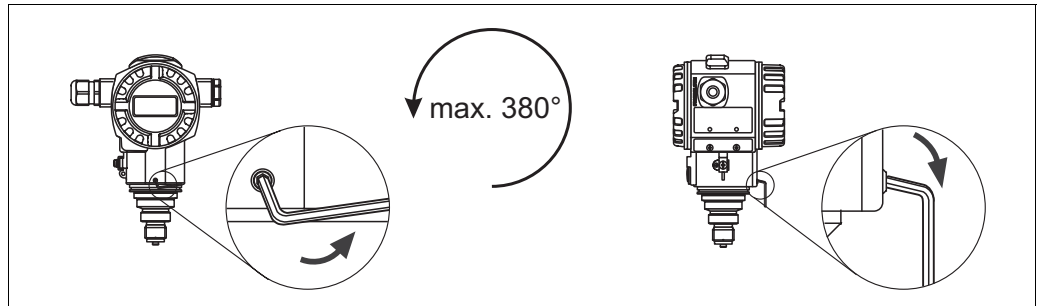

Fig. 15: Aligning the housing

- T14 and T15 housing: Loosen setscrew with a 2 mm Allen key.
- Hygienic T17 housing: Loosen setscrew with a 3 mm Allen key.
- Rotate housing (max. up to 380°).
- Retighten setscrew.

3.3.9 Close cover on a hygienic stainless steel housing (T17)

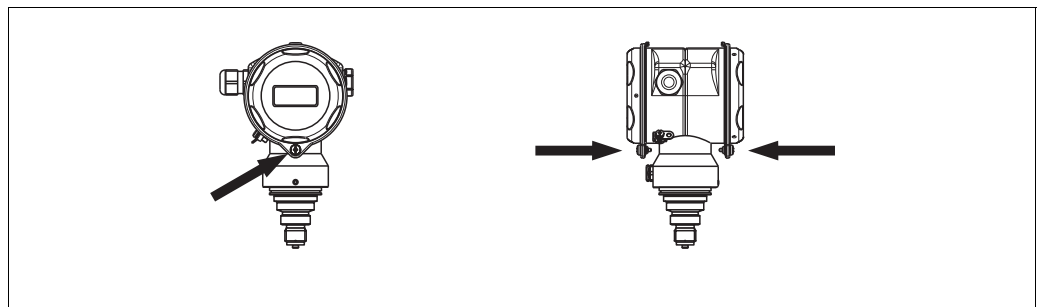

Fig. 16: Close cover

The covers for the terminal and electronics compartment are hooked into the casing and closed with a screw. These screws should be finger-tightened (2 Nm) to the stop to ensure that the covers sit tightly.

3.4 Post-installation check

After installing the device, carry out the following checks:

- Are all screws firmly tightened?
- Are the housing covers screwed down tight?

4 Wiring

4.1 Connecting the device



Note!

- When using the measuring device in hazardous areas, installation must comply with the corresponding national standards and regulations and the Safety Instructions or Installation or Control Drawings.
- Devices with integrated overvoltage protection must be earthed.
- Protective circuits against reverse polarity, HF influences and overvoltage peaks are installed.

- The supply voltage must match the supply voltage on the nameplate. (→ See also Page 6, Section 2.1.1 Nameplate.)
- Switch off the supply voltage before connecting the device.
- Remove housing cover of the terminal compartment.
- Guide cable through the gland. Preferably use twisted, screened two-wire cable.
- Connect device in accordance with the following diagram.
- Screw down housing cover.
- Switch on supply voltage.

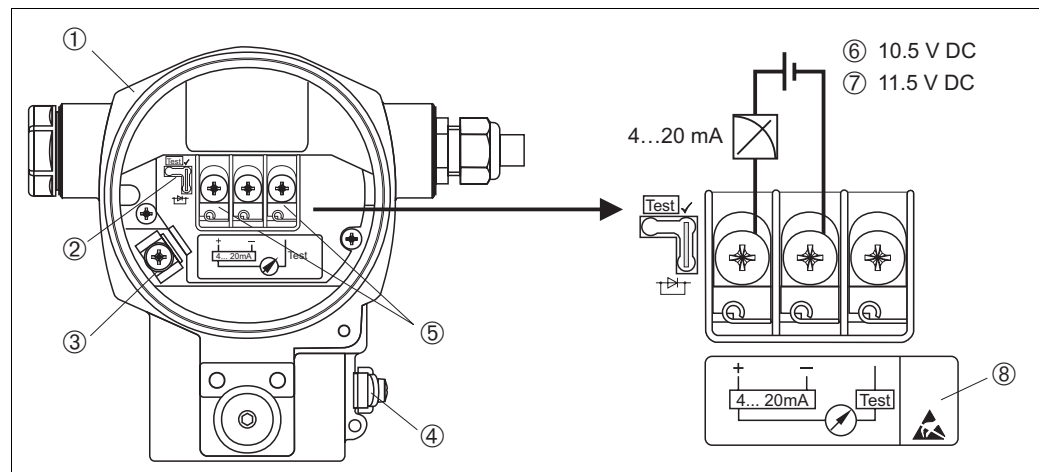

Fig. 17: Electrical connection 4...20 mA HART
→ Observe also Section 4.2.1 "Supply voltage", Page 22.

- 1 Housing
- 2 Jumper for 4...20 mA test signal.
→ See also Page 22, Section 4.2.1, "Taking 4...20 mA test signal" part.
- 3 Internal earth terminal
- 4 External earth terminal
- 5 4...20 mA test signal between plus and test terminal
- 6 Minimum supply voltage = 10.5 V DC, jumper is inserted in accordance with the illustration.
- 7 Minimum supply voltage = 11.5 V DC, jumper is inserted in "Test" position.
- 8 Devices with integrated overvoltage protection are labelled OVP (overvoltage protection) here.

4.1.1 Connecting devices with Harting plug Han7D

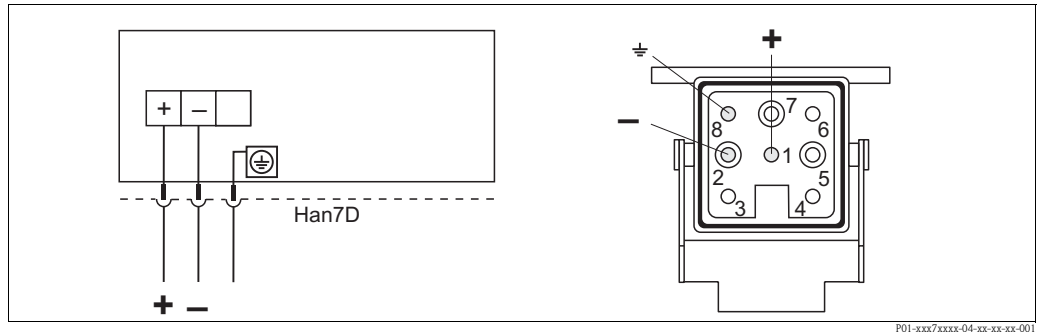

Fig. 18: Left: electrical connection for devices with Harting plug Han7D
Right: view of the plug connector at the device

4.1.2 Connecting devices with M12 plug

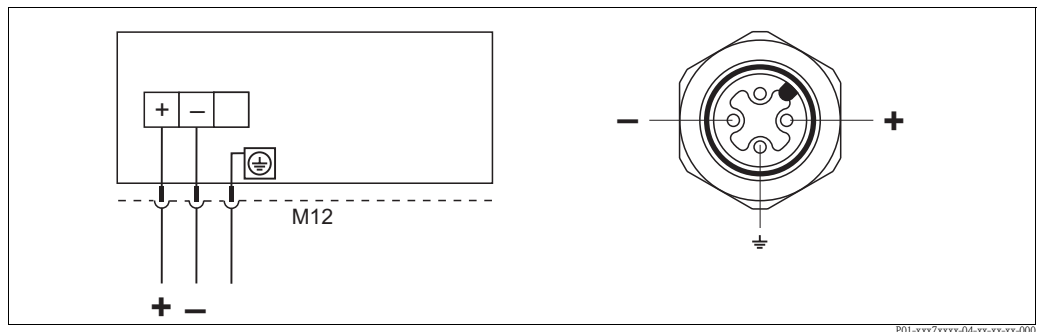

Fig. 19: Left: electrical connection for devices with M12 plug
Right: view of the plug at the device

4.2 Connecting the measuring unit

4.2.1 Supply voltage



Note!

- All explosion protection data are given in separate documentation which is available upon request. The Ex documentation is supplied as standard with all devices approved for use in explosion hazardous areas.
- When using the measuring device in hazardous areas, installation must comply with the corresponding national standards and regulations and the Safety Instructions or Installation or Control Drawings.

Electronic version	Jumper for 4...20 mA test signal in "Test" position (Delivery status)	Jumper for 4...20 mA test signal in "Non-Test" position
4...20 mA HART, for non-hazardous areas	11.5...45 V DC	10.5...45 V DC

Taking 4...20 mA test signal

A 4...20 mA signal may be measured via the positive and test terminal without interrupting the measurement. The minimum supply voltage of the device can be reduced by simply changing the position of the jumper. As a result, operation is also possible with lower voltage sources. To keep the measured error below 0.1%, the current measuring device should display an internal resistance of $< 0.7 \Omega$. Observe the position of the jumper in accordance with the following table.

Jumper position for test signal	Description
	<ul style="list-style-type: none"> – Taking 4...20 mA test signal via plus and test terminal: possible. (Thus, the output current can be measured without interruption via the diode.) – Delivery status – minimum supply voltage: 11.5 V DC
	<ul style="list-style-type: none"> – Taking 4...20 mA test signal via plus and test terminal: not possible. – minimum supply voltage: 10.5 V DC

4.2.2 Cable specification

- Endress+Hauser recommends using twisted, screened two-wire cables.
- Terminals for wire cross-sections 0.5...2.5 mm²
- Cable external diameter: 5...9 mm

4.2.3 Load

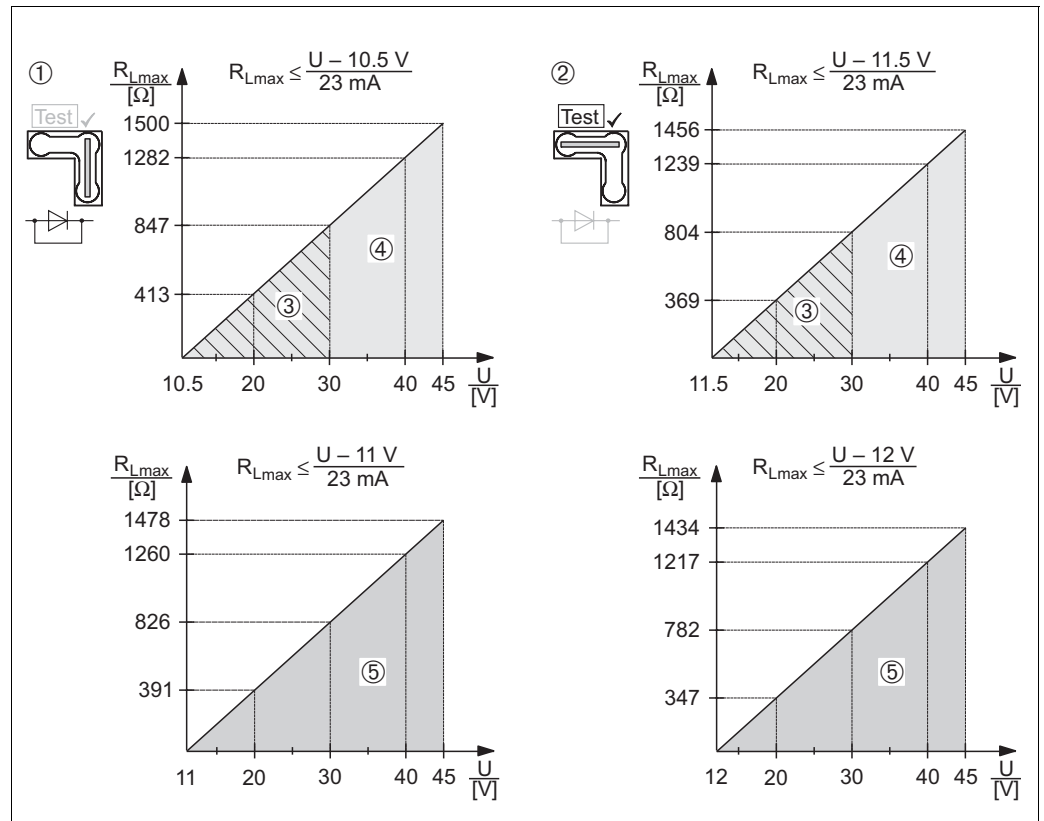

Fig. 20: Load diagram, observe the position of the jumper and the explosion protection. (→ See also Page 22, "Taking 4...20 mA test signal" part.)

- 1 Jumper for the 4...20 mA test signal inserted in "Non-Test" position
 - 2 Jumper for the 4...20 mA test signal inserted in "Test" position
 - 3 Supply voltage 10.5 (11.5)...30 V DC for 1/2 G, 1 GD, 1/2 GD, FM IS, CSA IS, IECEx ia, NEPSI Ex ia
 - 4 Supply voltage 10.5 (11.5)...45 V DC for devices for non-hazardous areas, 1/2 D, 1/3 D, 2 G EEx d, 3 G EEx nA, FM XP, FM DIP, FM NI, CSA XP and CSA Dust-Ex, NEPSI Ex d
 - 5 Supply voltage 11 (12)...45 V DC for PMC71, EEx d[ia], NEPSI Ex d[ia]
- R_{Lmax} Maximum load resistance
 U Supply voltage



Note!

When operating via a handheld terminal or via PC with an operating program, a minimum communication resistance of 250 Ω must exist within the loop.

4.2.4 Screening/potential matching

- You achieve optimum screening against disturbances if the screening is connected on both sides (in the cabinet and on the device). If you have to reckon with potential equalisation currents in the plant, only earth screening on one side, preferably at the transmitter.
- When using in hazardous areas, you must observe the applicable regulations. Separate Ex documentation with additional technical data and instructions is included with all Ex systems as standard.

4.2.5 Connecting HART handheld terminal

With a HART handheld terminal you can set and check the transmitter and avail of additional functions all along the 4...20 mA line.

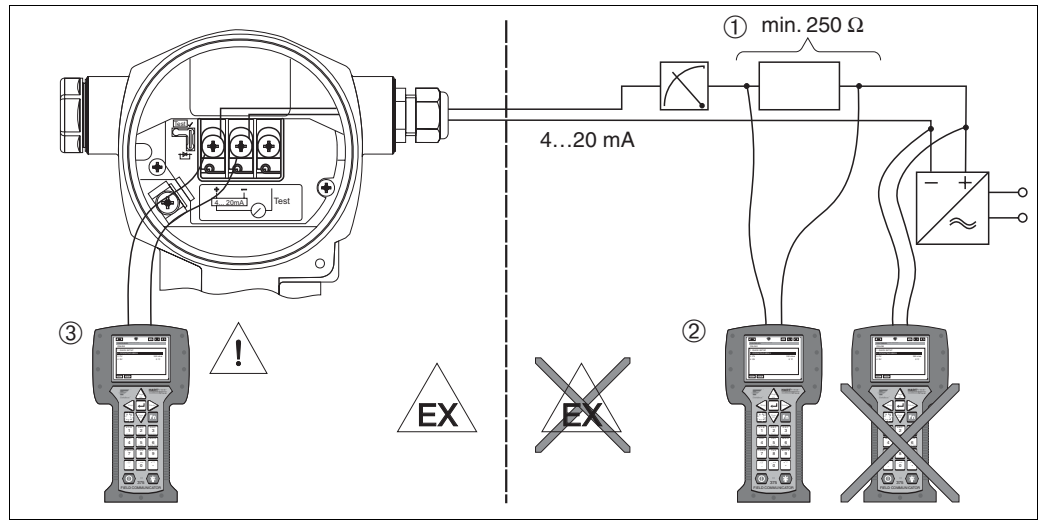

Fig. 21: Connecting an HART handheld terminal, e.g. Field Communicator 375

- 1 Necessary communication resistor $\geq 250 \Omega$
- 2 HART handheld terminal
- 3 HART handheld terminal, directly connected to the device even in the Ex i-area



Warning!

- In the case of Ex d type of protection, do not connect the handheld terminal in the hazardous area.
- Do not replace the battery of the handheld terminal in the hazardous area.
- For devices with FM or CSA certificates, establish electrical connection as per Installation or Control Drawing (ZD) supplied.

4.2.6 Connecting Commubox FXA191/FXA195 for operation via FieldCare

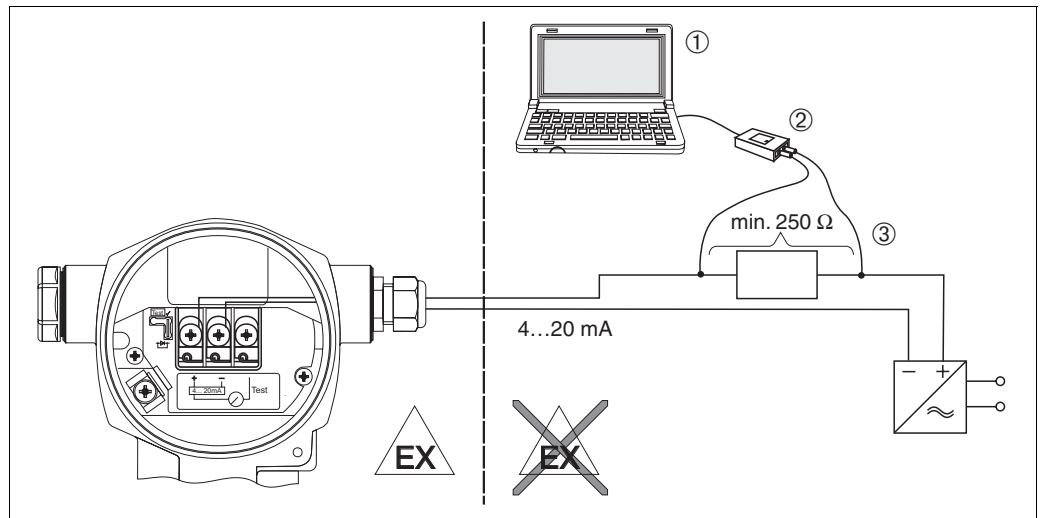

Fig. 22: Connecting PC with operating program FieldCare via Commubox FXA191/FXA195

- 1 Computer with operating program FieldCare
- 2 Commubox FXA191/FXA195
- 3 Necessary communication resistor $\geq 250 \Omega$

Connecting Commubox FXA191

The Commubox FXA191 connects intrinsically safe transmitters to a computer's serial interface (RS 232C) using the HART protocol. This allows remote operation of the measuring transmitter using Endress+Hauser's operating program FieldCare. The Commubox is supplied with power through the serial interface. The Commubox is also suitable for connection to intrinsically safe circuits. → See Technical Information TI404F for further information.

Connecting Commubox FXA195

The Commubox FXA195 connects intrinsically safe transmitters to a computer's USB port using the HART protocol. This allows remote operation of the measuring transmitter using Endress+Hauser's operating program FieldCare. The Commubox is supplied with power through the USB port. The Commubox is also suitable for connection to intrinsically safe circuits. → See Technical Information TI237F for further information.

4.2.7 Connecting Commubox FXA291/ToF Adapter FXA291 for operation via FieldCare

Connecting Commubox FXA291

The Commubox FXA291 connects Endress+Hauser field instruments with CDI interface (= Endress+Hauser Common Data Interface) to the USB interface of a personal computer or a notebook. For details refer to TI405C/07/en.



Note!

For the following Endress+Hauser instruments you need the "ToF Adapter FXA291" as an additional accessory:

- Cerabar S PMC71, PMP7x
- Deltabar S PMD7x, FMD7x
- Deltapilot S FMB70

Connecting ToF Adapter FXA291

The ToF Adapter FXA291 connects the Commubox FXA291 via the USB interface of a personal computer or a notebook to the following Endress+Hauser instruments:

- Cerabar S PMC71, PMP7x
- Deltabar S PMD7x, FMD7x
- Deltapilot S FMB70

For details refer to KA271F/00/a2.

4.3 Potential matching

Ex applications: Connect all devices to the local potential matching.
Observe the applicable regulations.

4.4 Overvoltage protection (optional)

Devices showing version "M" in feature 100 "Additional options 1" or feature 110 "Additional options 2" in the order code are equipped with overvoltage protection (see also Technical Information TI383P "Ordering information").

- Overvoltage protection:
 - Nominal functioning DC voltage: 600 V
 - Nominal discharge current: 10 kA
- Surge current check $\hat{i} = 20$ kA as per DIN EN 60079-14: 8/20 μ s satisfied
- Arrester AC current check $I = 10$ A satisfied



Warning!

Devices with integrated overvoltage protection must be earthed.

4.5 Post-connection check

Perform the following checks after completing electrical installation of the device:

- Does the supply voltage match the specifications on the nameplate?
- Is the device connected as per Section 4.1?
- Are all screws firmly tightened?
- Are the housing covers screwed down tight?

As soon as voltage is applied to the device, the green LED on the electronic insert lights up for a few seconds or the connected on-site display lights up.

5 Operation

Feature 20 "Output; operation" in the order code provides you with information on the operating options available to you.

Versions in the order code		Operation
A	4...20 mA HART; external operation, LCD	Via on-site display and 3 keys on the exterior of the device
B	4...20 mA HART; internal operation, LCD	Via on-site display and 3 keys on the inside of the device
C	4...20 mA; internal operation	Without on-site display, 3 keys on the inside of the device

5.1 On-site display (optional)

A 4-line liquid crystal display (LCD) is used for display and operation. The on-site display shows measured values, dialog texts, fault messages and notice messages.

The display of the device can be turned in 90° steps.

Depending on the installation position of the device, this makes it easy to operate the device and read the measured values.





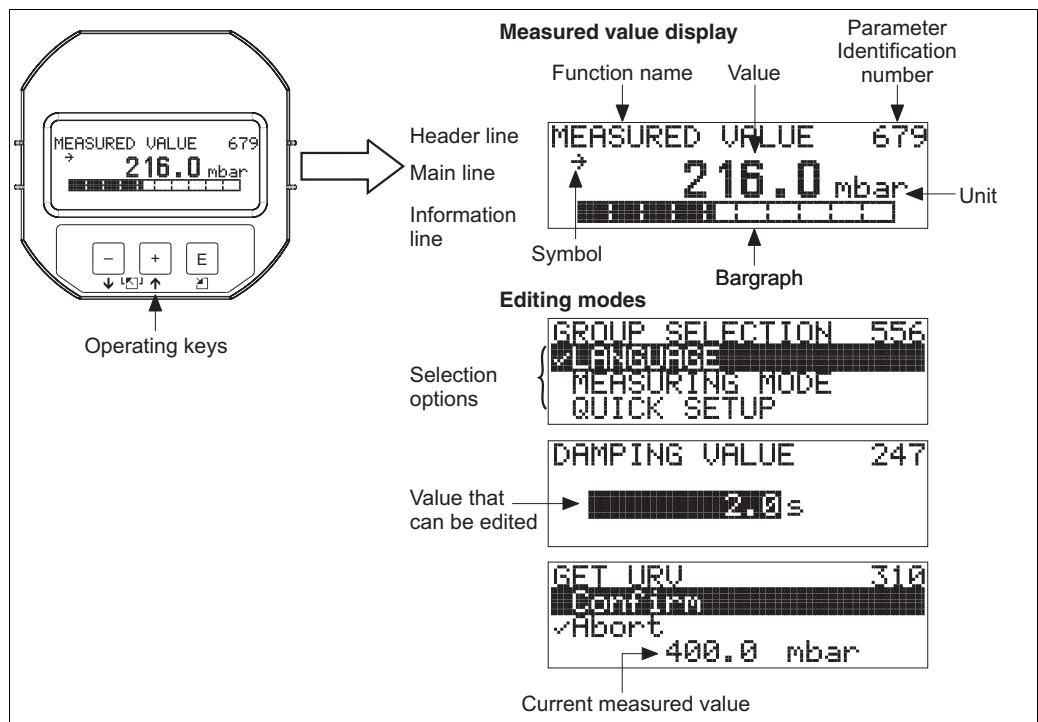

Functions:

- 8-digit measured value display including sign and decimal point, bargraph for current display
- simple and complete menu guidance thanks to separation of the parameters into several levels and groups
- each parameter is given a 3-digit ID number for easy navigation
- option for configuring the display according to individual requirements and desires, such as language, alternating display, contrast setting, display of other measured values such as sensor temperature
- comprehensive diagnostic functions (fault and warning message, peak-hold indicators, etc.)
- rapid and safe commissioning with the Quick Setup menus



P01-xMx7xxxx-07-xx-xx-xx-001

The following table illustrates the symbols that can appear on the on-site display. Four symbols can occur at one time.

Symbol	Meaning
	Alarm symbol – Symbol flashing: warning, device continues measuring. – Symbol permanently lit: error, device does not continue measuring. <i>Note:</i> The alarm symbol may overlie the tendency symbol.
	Lock symbol The operation of the device is locked. Unlock device, → see Section 5.10.
	Communication symbol Data transfer via communication <i>Note:</i> The alarm symbol may overlie the communication symbol.
	Tendency symbol (increasing) The measured value is increasing.
	Tendency symbol (decreasing) The measured value is decreasing.
	Tendency symbol (constant) The measured value has remained constant over the past few minutes.

5.2 Operating elements

5.2.1 Position of operating elements

With regard to aluminium or stainless steel housings (T14), the operating keys are located either outside the device under the protection cap or inside on the electronic insert. In hygienic stainless steel housings (T17), the operating keys are always located inside on the electronic insert.

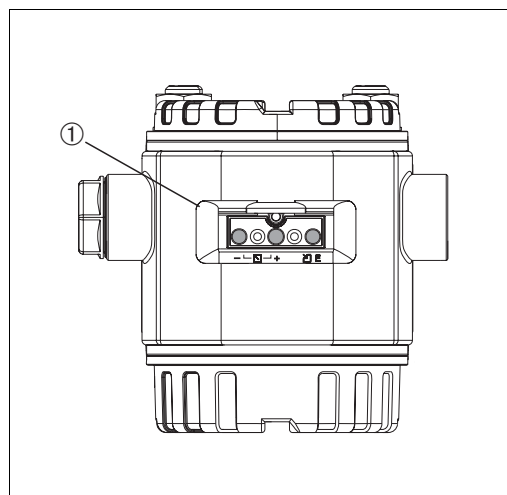

P01-PMx7xxxx-19-xx-xx-xx-009

Fig. 23: Operating keys, external

- 1 Operating keys on the exterior of the device under the protective flap

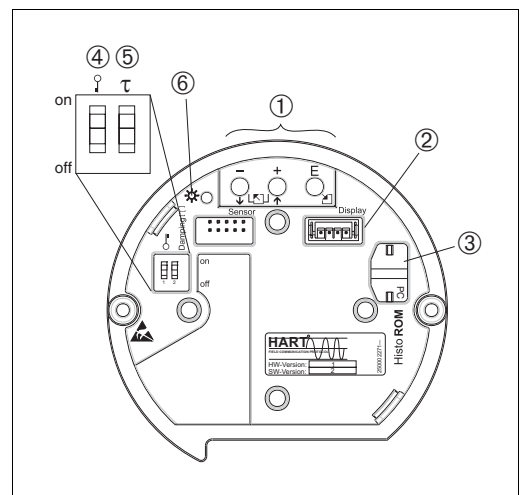











P01-xxxxxxx-19-xx-xx-xx-104

Fig. 24: Operating keys, internal







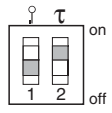

- 1 Operating keys
- 2 Slot for optional display
- 3 Slot for optional HistoROM®/M-DAT
- 4 DIP-switch for locking/unlocking measured-value-relevant parameters
- 5 DIP-switch for damping on/off
- 6 Green LED to indicate value being accepted

5.2.2 Function of the operating elements – on-site display not connected

Press and hold the key or the key combination for at least 3 seconds to execute the corresponding function. Press the key combination for at least 6 seconds for a reset.

Operating key(s)	Meaning
	Adopt lower range value. A reference pressure is present at the device. → See also Page 32, Section 5.3.1 "Pressure measuring mode" or Page 33, Section 5.3.2 "Level measuring mode".
	Adopt upper range value. A reference pressure is present at the device. → See also Page 32, Section 5.3.1 "Pressure measuring mode" or Page 33, Section 5.3.2 "Level measuring mode".
	Position adjustment
 and  and 	Reset all parameters. The reset via operating keys corresponds to the software reset code 7864.
 and 	Copy the configuration data from the optional HistoROM®/M-DAT module to the device.
 and 	Copy the configuration data from the device to the optional HistoROM®/M-DAT module.
 P01-xxxxxxx-19-xx-xx-xx-057	<ul style="list-style-type: none"> – DIP-switch 1: for locking/unlocking measured-value-relevant parameters Factory setting: off (unlocked) – DIP-switch 2: damping on/off, Factory setting: on (damping on)

5.2.3 Function of the operating elements – on-site display connected

Operating key(s)	Meaning
	<ul style="list-style-type: none"> – Navigate upwards in the picklist – Edit the numerical values and characters within a function
	<ul style="list-style-type: none"> – Navigate downwards in the picklist – Edit the numerical values and characters within a function
	<ul style="list-style-type: none"> – Confirm entry – Jump to the next item
 and 	Contrast setting of on-site display: darker
 and 	Contrast setting of on-site display: brighter
 and 	<p>ESC functions:</p> <ul style="list-style-type: none"> – Exit edit mode without saving the changed value. – You are in a menu within a function group. The first time you press the keys simultaneously, you go back a parameter within the function group. Each time you press the keys simultaneously after that, you go up a level in the menu. – You are in a menu at a selection level. Each time you press the keys simultaneously, you go up a level in the menu. <p><i>Note:</i> The terms function group, level and selection level are explained in Section 5.4.1, Page 35.</p>

5.3 On-site operation – on-site display not connected



Note!

To operate the device with a HistoROM®/M-DAT module see Page 37, Section 5.5 "HistoROM®/M-DAT module".

5.3.1 Pressure measuring mode

If no on-site display is connected, the following functions are possible by means of the three keys on the electronic insert or on the exterior of the device:

- Position adjustment (zero point correction)
- Setting lower range value and upper range value
- Device reset, → see also Page 30, Section 5.2.2 "Function of the operating elements", Table.



Note!

- The operation must be unlocked. → See Page 42, Section 5.9 "Locking /unlocking operation".
- The device is configured for the Pressure measuring mode as standard. You can switch measuring modes by means of the MEASURING MODE parameter. → See Page 45, Section 6.2 "Selecting language and measuring mode".
- The pressure applied must be within the nominal pressure limits of the sensor. See information on the nameplate.

Carry out position adjustment. ¹		Setting lower range value.		Setting upper range value.	
Pressure is present at device.		Desired pressure for lower range value is present at device.		Desired pressure for upper range value is present at device.	
↓		↓		↓	
Press "E"-key for 3 s.		Press "-"-key for 3 s.		Press "+"-key for 3 s.	
↓		↓		↓	
Does the LED on the electronic insert light up briefly?		Does the LED on the electronic insert light up briefly?		Does the LED on the electronic insert light up briefly?	
Yes	No	Yes	No	Yes	No
↓	↓	↓	↓	↓	↓
Applied pressure for position adjustment has been accepted.	Applied pressure for position adjustment has not been accepted. Observe the input limits.	Applied pressure for lower range value has been accepted.	Applied pressure for lower range value has not been accepted. Observe the input limits.	Applied pressure for upper range value has been accepted.	Applied pressure for upper range value has not been accepted. Observe the input limits.

1) Observe "Warning" on page 45 in Chapter 6 "Commissioning".

5.3.2 Level measuring mode

If no on-site display is connected, the following functions are possible by means of the three keys on the electronic insert or on the exterior of the device:

- Position adjustment (zero point correction)
- Set the lower and upper pressure value and assign to the lower and upper level value
- Device reset, → see also Page 30, Section 5.2.2 "Function of the operating elements", Table.



Note!

- The "-" and "+"- keys only have a function in the following cases:
 - LEVEL SELECTION "Level Easy Pressure", CALIBRATION MODE "Wet"
 - LEVEL SELECTION "Level Standard", LEVEL MODE "Linear", CALIBRATION MODE "Wet"

The keys have no function in other settings.

- The device is configured for the Pressure measuring mode as standard. You can switch measuring modes by means of the MEASURING MODE parameter. → See Page 45, Section 6.2 "Selecting language and measuring mode".

The following parameters are set to the following values in the factory:

- LEVEL SELECTION: Level Easy Pressure
- CALIBRATION MODE: Wet
- OUTPUT UNIT or LIN. MEASURAND: %
- EMPTY CALIB.: 0.0
- FULL CALIB.: 100.0.
- SET LRV: 0.0 (corresponds to 4 mA value)
- SET URV: 100.0 (corresponds to 20 mA value)

These parameters can only be modified by means of the on-site display or remote operation such as the FieldCare.

- The operation must be unlocked. → See Page 42, Section 5.9 "Locking /unlocking operation".
- The pressure applied must be within the nominal pressure limits of the sensor. See information on the nameplate.
- → See also Page 50, Section 6.5 "Level measurement". For parameter description see Operating Instructions BA274P.
- LEVEL SELECTION, CALIBRATION MODE, LEVEL MODE, EMPTY CALIB., FULL CALIB, SET LRV and SET URV are parameter names used for on-site display or remote operation such as FieldCare, for instance.

Carry out position adjustment.¹		Setting lower pressure value.		Setting upper pressure value.	
Pressure is present at device.		Desired pressure for lower pressure value (EMPTY PRESSURE ²) is present at device.		Desired pressure for upper pressure value (FULL PRESSURE ¹) is present at device.	
↓		↓		↓	
Press "E"-key for 3 s.		Press "-"-key for 3 s.		Press "+"-key for 3 s.	
↓		↓		↓	
Does the LED on the electronic insert light up briefly?		Does the LED on the electronic insert light up briefly?		Does the LED on the electronic insert light up briefly?	
Yes	No	Yes	No	Yes	No
↓	↓	↓	↓	↓	↓
Applied pressure for position adjustment has been accepted.	Applied pressure for position adjustment has not been accepted. Observe the input limits.	The pressure present was saved as the lower pressure value (EMPTY PRESSURE ¹) and assigned to the lower level value (EMPTY CALIB. ¹).	The pressure present was not saved as the lower pressure value. Observe the input limits.	The pressure present was saved as the upper pressure value (FULL PRESSURE ¹) and assigned to the upper level value (FULL CALIB. ¹).	The pressure present was not saved as the upper pressure value. Observe the input limits.

- 1) Observe "Warning" on page 45 in Chapter 6 "Commissioning".
- 2) Parameter name used for the on-site display or remote operation such as the FieldCare.

5.4 On-site operation – on-site display connected

If the on-site display is connected, the three operating keys are used to navigate through the operating menu, → see Page 31, Section 5.2.3 "Function of the operating elements".

5.4.1 General structure of the operating menu

The menu is split into four levels. The three upper levels are used to navigate while you use the bottom level to enter numerical values, select options and save settings. The entire menu is illustrated in Section 10.1 "Menu for on-site display and digital communication".

The structure of the OPERATING MENU depends on the measuring mode selected, e.g. if the "Pressure" measuring mode is selected, only the functions necessary for this mode are displayed.

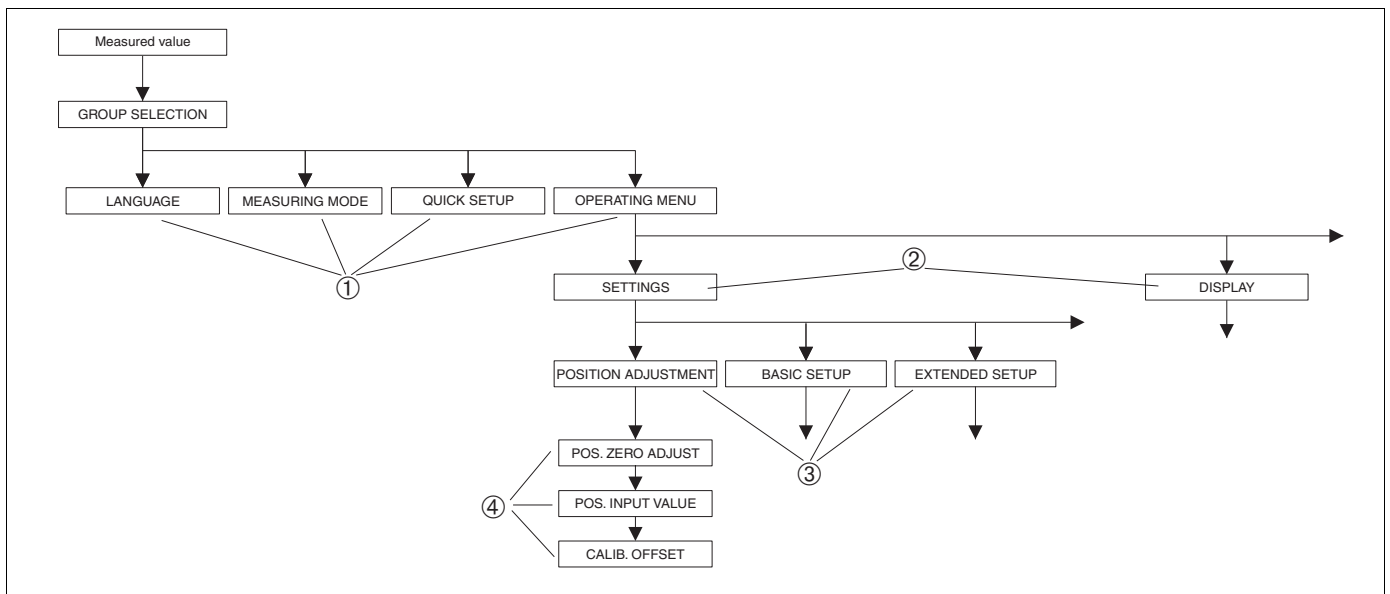

Fig. 25: Structure of the operating menu

- 1 1. Selection level
- 2 2. Selection level
- 3 Function groups
- 4 Parameter



Note!

The LANGUAGE and MEASURING MODE parameters are only displayed via the on-site display on the 1st selection level. In the digital communication, the LANGUAGE parameter is displayed in the DISPLAY group and the MEASURING MODE parameter is displayed in the QUICK SETUP menus or in the BASIC SETUP function group. → See also Section 10.1 "Operating menu for on-site display and digital communication".

5.4.2 Selecting an option

Example: select "English" as the language of the menu.

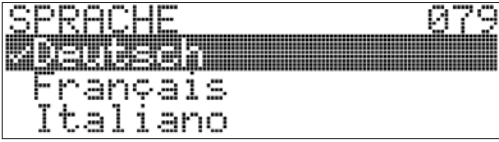
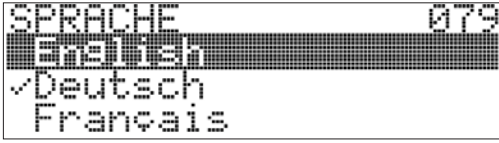
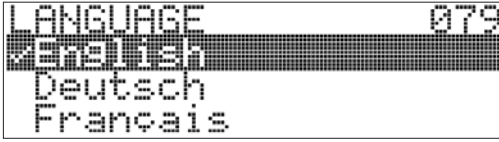
On-site display	Operation
 <p>SPRACHE 079 ✓Deutsch Français Italiano</p> <p style="text-align: right; font-size: small;">P01-xxxxxxx-19-xx-xx-xx-017</p>	<p>German is selected as the language. A ✓ in front of the menu text indicates the active option.</p>
 <p>SPRACHE 079 English ✓Deutsch Français</p> <p style="text-align: right; font-size: small;">P01-xxxxxxx-19-xx-xx-xx-033</p>	<p>Select English with "+" or "-".</p>
 <p>LANGUAGE 079 ✓English Deutsch Français</p> <p style="text-align: right; font-size: small;">P01-xxxxxxx-19-xx-xx-xx-034</p>	<ol style="list-style-type: none"> 1. Confirm your choice with "E". A ✓ in front of the menu text indicates the active option. (English is now selected as the menu language.) 2. Jump to the next item with "E".

5.4.3 Editing a value

Example: adjusting DAMPING VALUE function from 2.0 s to 30.0 s. → See also Page 31, Section 5.2.3 "Function of the operating elements".

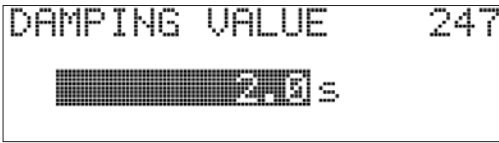
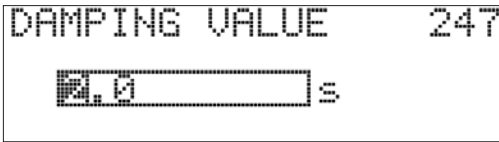
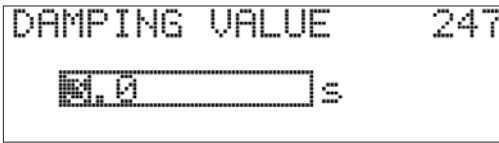
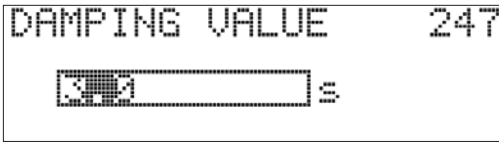
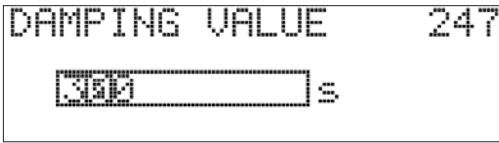
On-site display	Operation
 <p>DAMPING VALUE 247 2.0 s</p> <p style="text-align: right; font-size: small;">P01-xxxxxxx-19-xx-xx-xx-023</p>	<p>The on-site display shows the parameter to be changed. The value highlighted in black can be changed. The "s" unit is fixed and cannot be changed.</p>
 <p>DAMPING VALUE 247 2.0 s</p> <p style="text-align: right; font-size: small;">P01-xxxxxxx-19-xx-xx-xx-027</p>	<ol style="list-style-type: none"> 1. Press "+" or "-" to get to the editing mode. 2. The first digit is highlighted in black.
 <p>DAMPING VALUE 247 3.0 s</p> <p style="text-align: right; font-size: small;">P01-xxxxxxx-19-xx-xx-xx-028</p>	<ol style="list-style-type: none"> 1. Use "+" to change "2" to "3". 2. Confirm "3" with "E". The cursor jumps to the next position (highlighted in black).
 <p>DAMPING VALUE 247 3.0 s</p> <p style="text-align: right; font-size: small;">P01-xxxxxxx-19-xx-xx-xx-029</p>	<p>The decimal point is highlighted in black, i.e. you can now edit it.</p>
 <p>DAMPING VALUE 247 30.0 s</p> <p style="text-align: right; font-size: small;">P01-xxxxxxx-19-xx-xx-xx-030</p>	<ol style="list-style-type: none"> 1. Keep pressing "+" or "-" until "0" is displayed. 2. Confirm "0" with "E". The cursor jumps to the next position. ↵ is displayed and is highlighted in black. → See next graphic.

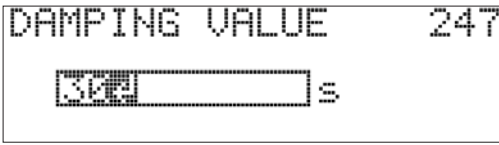
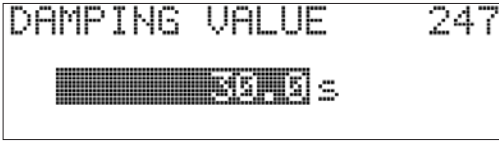
On-site display	Operation
 <p>P01-xxxxxxxx-19-xx-xx-xx-031</p>	Use "E" to save the new value and exit the editing mode. →See next graphic.
 <p>P01-xxxxxxxx-19-xx-xx-xx-032</p>	The new value for the damping is now 30.0 s. – Jump to the next parameter with "E". – You can get back to the editing mode with "+" or "-".

5.4.4 Taking pressure applied at device as value

Example: configuring upper range value – assign 20 mA to the pressure value 400 mbar.

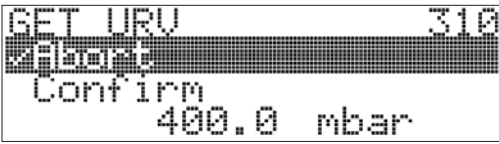
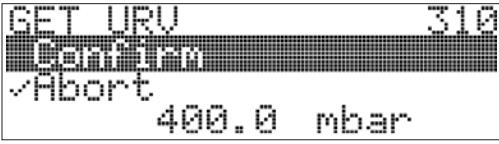
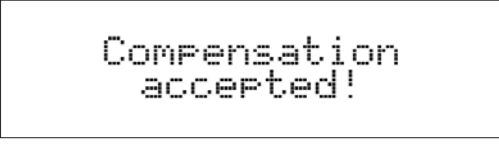
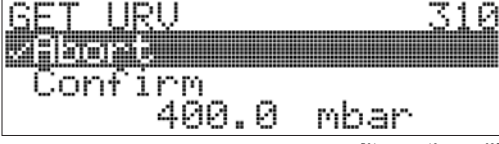
On-site display	Operation
 <p>P01-xxxxxxxx-19-xx-xx-xx-035</p>	The bottom line on the on-site display displays the pressure present, here 400 mbar.
 <p>P01-xxxxxxxx-19-xx-xx-xx-036</p>	Use "+" or "-" to switch to the "Confirm" option. The active selection is highlighted in black.
 <p>P01-xxxxxxxx-19-xx-xx-xx-037</p>	Use "E" to assign the value (400 mbar) to the GET URV parameter. The device confirms the calibration and jumps back to the parameter, here GET URV (see next graphic).
 <p>P01-xxxxxxxx-19-xx-xx-xx-035</p>	Switch to the next parameter with "E".

5.5 HistoROM®/M-DAT (optional)

HistoROM®/M-DAT is a memory module, which is attached to the electronic insert and fulfils the following functions:

- Back-up copy of configuration data
- Copying configuration data of a transmitter into another transmitter
- Cyclic recording of pressure and sensor-temperature measured values
- Recording diverse events, such as alarms, configuration changes, counters for measuring range undershooting and exceeding for pressure and temperature, exceeding and undershooting the user limits for pressure and temperature, etc.



Warning!

Detach HistoROM®/M-DAT from the electronic insert or attach it to the insert in a deenergised state only.



Note!

- The HistoROM®/M-DAT module may be retrofitted at any time (Order No.: 52027785).
- The HistoROM data and the data in the device are analysed once a HistoROM®/M-DAT is attached to the electronic insert and power is reestablished to the device. During the analysis, the messages "W702, HistoROM data not consistent" and "W706, Configuration in HistoROM and device not identical" can occur. For measures, see Page 55, Section 8.1 "Messages."

5.5.1 Copying configuration data



Abb. 26: Electronic insert with optional HistoROM®/M-DAT memory module

1 optional HistoROM®/M-DAT

2 To copy configuration data from the HistoROM®/M-DAT module to a device or from a device to a HistoROM®/M-DAT, the operation must be unlocked DIP-switch 1, Position "off", parameter INSERT PIN NO. = 100). Observe Page 42, Section 5.9 "Locking/unlocking operation".

On-site operation – on-site display not connected

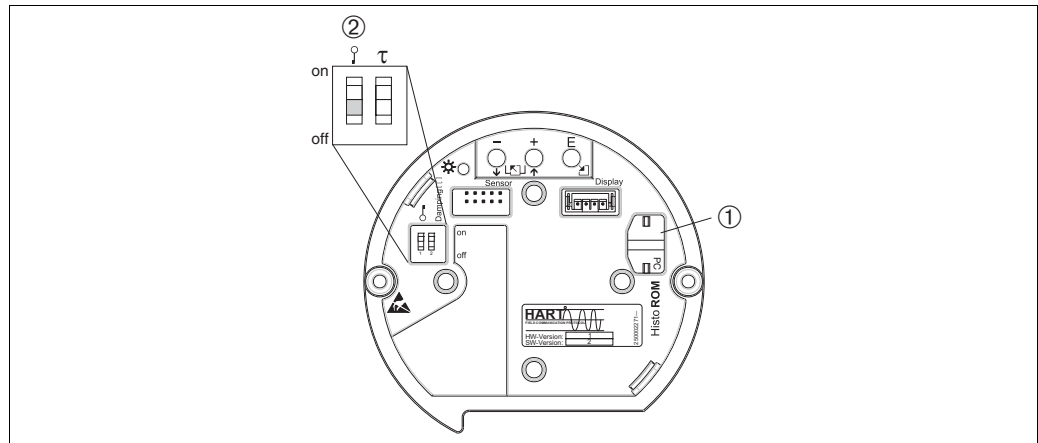
Copying configuration data from a device to a HistoROM®/M-DAT module:



Note!

The operation must be unlocked.

1. Disconnect device from supply voltage.
2. Attach the HistoROM®/M-DAT module to the electronic insert.
3. Reestablish supply voltage to the device.
4. Press "E" and "-"-keys (for at least 3 seconds) until the LED on the electronic insert lights up.
5. Wait approx. 20 seconds. Configuration data are loaded from the device to the HistoROM®/M-DAT. The device is not restarted.
6. Disconnect device from the supply voltage again.
7. Detach memory module.
8. Reestablish supply voltage to the device.

Copying configuration data from a HistoROM®/M-DAT to a device:

Note!

The operation must be unlocked.

1. Disconnect device from supply voltage.
2. Attach the HistoROM®/M-DAT module to the electronic insert. Configuration data from another device are stored in the HistoROM®/M-DAT.
3. Reestablish supply voltage to the device.
4. Press "E" and "+"-keys (for at least 3 seconds) until the LED on the electronic insert lights up.
5. Wait approx. 20 seconds. All parameters except DEVICE SERIAL No, DEVICE DESIGN., CUST. TAG NUMBER, LONG TAG NUMBER, DESCRIPTION, BUS ADDRESS and the parameters in the POSITION ADJUSTMENT and PROCESS CONNECTION group are loaded into the device by HistoROM®/M-DAT. The device is restarted.
6. Before removing the HistoROM®/M-DAT again from the electronic insert, disconnect the device from supply voltage.

On-site operation via on-site display (optional) or remote operation**Copying configuration data from a device to a HistoROM®/M-DAT:**

Note!

The operation must be unlocked.

1. Disconnect device from supply voltage.
2. Attach the HistoROM®/M-DAT module to the electronic insert.
3. Reestablish supply voltage to the device.
4. The DOWNLOAD SELECT. parameter setting has no influence on an upload from the device into HistoROM.
(Menu path: (GROUP SELECTION →) OPERATING MENU → OPERATION)
5. Using the HistoROM CONTROL parameter select the option "Device → HistoROM" as the data transfer direction.
(Menu path: GROUPSELECTION → OPERATING MENU → OPERATION)
6. Wait approx. 20 seconds. Configuration data are loaded from the device to the HistoROM®/M-DAT. The device is not restarted.
7. Disconnect device from the supply voltage again.
8. Detach memory module.
9. Reestablish supply voltage to the device.

Copying configuration data from a HistoROM®/M-DAT to a device:

Note!

The operation must be unlocked.

1. Disconnect device from supply voltage.
2. Attach the HistoROM®/M-DAT module to the electronic insert. Configuration data from another device are stored in the HistoROM®/M-DAT.
3. Reestablish supply voltage to the device.
4. Use the DOWNLOAD SELECT parameter to select which parameters are to be overwritten (Menu path: (GROUPS SELECTION →) OPERATING MENU → OPERATION).

The following parameters are overwritten according to the selection:

– **Configuration copy (factory setting):**

all parameters except DEVICE SERIAL No., DEVICE DESIGN, CUST. TAG NUMBER, LONG TAG NUMBER, DESCRIPTION, BUS ADDRESS and the parameters in the POSITION ADJUSTMENT, PROCESS CONNECTION, CURR. TRIM (SERVICE/SYSTEM 2), SENSOR TRIM and SENSOR DATA group.

– **Device replacement:**

all parameters except DEVICE SERIAL No., DEVICE DESIGN and the parameters in the POSITION ADJUSTMENT, PROCESS CONNECTION, CURR. TRIM (SERVICE/SYSTEM 2), SENSOR TRIM and SENSOR DATA group.

– **Electronics replace:**

all parameters except the parameters in the CURR. TRIM (SERVICE/SYSTEM 2), POSITION ADJUSTMENT and SENSOR DATA group.

Factory setting: Configuration copy

5. Using the HistoROM CONTROL parameter select the option "HistoROM → Device" as the data transfer direction.
(Menu path: GROUP SELECTION → OPERATING MENU → OPERATION)
6. Wait approx. 20 seconds. Configuration data are loaded from the device to the HistoROM®/M-DAT. The device is restarted.
7. Before removing the HistoROM®/M-DAT again from the electronic insert, disconnect the device from supply voltage.

5.6 Operation via HART handheld terminal

Use the HART handheld terminal to set all parameters all the way along the 4...20 mA cable via menu operation.

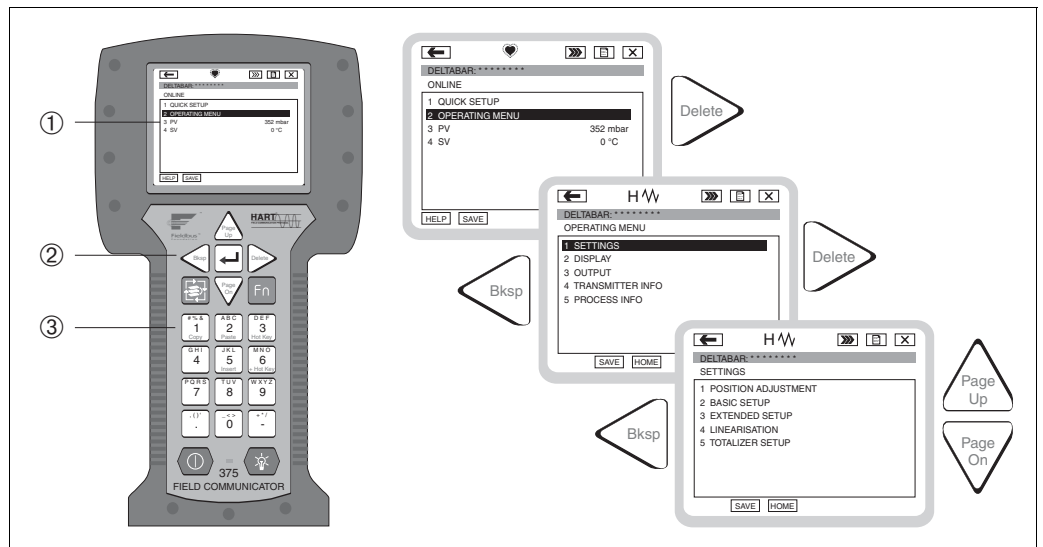

Fig. 27: HART handheld terminal, here e.g. Field Communicator 375 and menu guidance

- 1 LC display with menu text
- 2 Keys for menu selection
- 3 Keys for parameter entry



Note!

- → See also Page 24, Section 4.2.5 "Connecting HART handheld terminal".
- For further information, please refer to the Operating Instructions for the handheld terminal. The Operating Instructions are supplied with the handheld terminal.

5.7 FieldCare

FieldCare is an Endress+Hauser asset management tool based on FDT technology. With FieldCare, you can configure all Endress+Hauser devices as well as devices from other manufacturers that support the FDT standard. The following operating systems are supported: WinNT4.0, Win2000 and Windows XP.

FieldCare supports the following functions:

- Configuration of transmitters in online operation
- Loading and saving device data (upload/download)
- HistoROM®/M-DAT analysis
- Documentation of the measuring point

Connection options:

- HART via Commubox FXA191 and the serial interface RS 232 C of a computer
- HART via Commubox FXA195 and USB interface of a computer
- HART via Fieldgate FXA520



Note!

- → See also Page 25, Section 4.2.6 "Connecting Commubox FXA191/FXA195 for operation via FieldCare".
- Further information on the FieldCare can be found on the Internet (<http://www.endress.com>, Download → Search for: FieldCare).

5.8 Locking/unlocking operation

Once you have entered all the parameters, you can lock your entries against unauthorised and undesired access.

You have the following possibilities for locking/unlocking the operation:

- Via a DIP-switch on the electronic insert, locally on the display.
- Via the on-site display (optional)
- Via digital communication.

The -symbol on the on-site display indicates that operation is locked. Parameters which refer to how the display appears, e.g. LANGUAGE and DISPLAY CONTRAST can still be altered.



Note!

- If operation is locked by means of the DIP-switch, you can only unlock operation again by means of the DIP-switch. If operation is locked by means of the on-site display or remote operation e.g. FieldCare, you can only unlock operation again by means of the on-site display or remote operation.

The table provides an overview of the locking functions:

Locking via	View/read parameter	Modify/write via ¹		Unlocking via		
		On-site display	Remote operation	DIP-switch	On-site display	Remote operation
DIP-switch	Yes	No	No	Yes	No	No
On-site display	Yes	No	No	No	Yes	Yes
Remote operation	Yes	No	No	No	Yes	Yes

1) Parameters which refer to how the display appears, e.g. LANGUAGE and DISPLAY CONTRAST can still be altered.

5.8.1 Locking/unlocking operation locally via DIP-switch

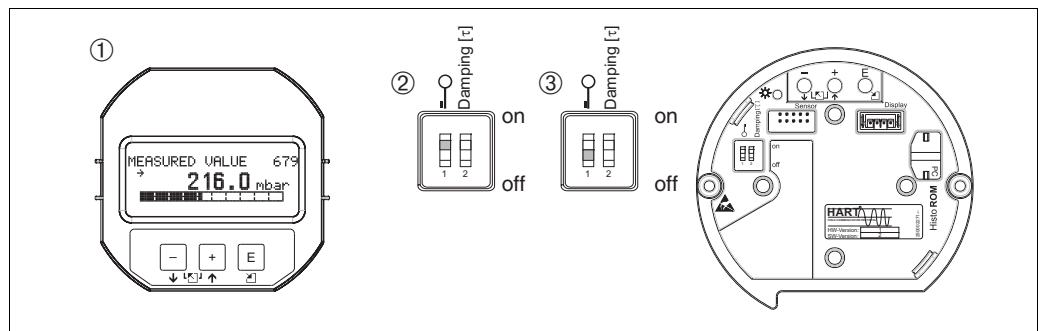

P01-xxxxxxx-19-xx-xx-xx-135

Fig. 28: DIP-switch position "Hardware locking" on the electronic insert

- 1 If necessary, remove on-site display (optional)
- 2 DIP-switch is at "on": operation is locked.
- 3 DIP-switch is at "off": operation is unlocked (operation possible)

5.8.2 Locking/unlocking operation via on-site display or remote operation

	Description
Locking operation	<ol style="list-style-type: none"> 1. Select INSERT PIN NO. parameter, Menu path: OPERATING MENU → OPERATION → INSERT PIN NO. 2. To lock operation, enter a number for this parameter between 0...9999 that is ≠100.
Unlocking operation	<ol style="list-style-type: none"> 1. Select INSERT PIN NO. parameter. 2. To unlock operation, enter "100" for the parameter.

5.9 Factory setting (reset)

By entering a certain code, you can completely, or partially, reset the entries for the parameters to the factory settings. (→ For factory settings refer to the Operating Instructions BA274P "Cerabar S/Deltabar S/Deltapilot S, Description of device functions". See also Page 2, "Overview documentation".) Enter the code by means of the ENTER RESET CODE parameter (Menu path: (GROUP SELECTION →) OPERATING MENU → OPERATING).

There are various reset codes for the device. The following table illustrates which parameters are reset by the particular reset codes. Operation must be unlocked to reset parameters (→ see Page 42, Section 5.9).



Note!

Any customer-specific configuration carried out by the factory is not affected by a reset (customer-specific configuration remains). If, after a reset, you wish the parameters to be reset to the factory settings, please contact Endress+Hauser Service.

Reset code	Description and effect
1846	Display reset <ul style="list-style-type: none"> – This reset resets all parameters which have to do with how the display appears (DISPLAY group). – Any simulation which may be running is ended. – The device is restarted.
62	PowerUp reset (warm start) <ul style="list-style-type: none"> – This reset resets all the parameters in the RAM. Data are read back anew from the EEPROM (processor is initialised again). – Any simulation which may be running is ended. – The device is restarted.
2710	Measuring mode level reset <ul style="list-style-type: none"> – Depending on the settings for the LEVEL MODE, LIN MEASURAND, LINdMEASURAND or COMB. MEASURAND parameters, the parameters needed for this measuring task will be reset. – Any simulation which may be running is ended. – The device is restarted. <p>Example LEVEL MODE = linear and LIN. MEASURAND = Height</p> <ul style="list-style-type: none"> ■ HEIGHT UNIT = m ■ CALIBRATION MODE = wet ■ EMPTY CALIB. = 0 ■ FULL CALIB. = Sensor end value converted to mH₂O, e.g. 4.79 mH₂O for a 400 mbar sensor
333	User reset <ul style="list-style-type: none"> – Affects the following parameters: <ul style="list-style-type: none"> – Function group POSITION ADJUSTMENT – Function group BASIC SETUP, except for the customer-specific units – Function group EXTENDED SETUP – Group OUTPUT – Function group HART DATA: BUS ADDRESS and PREAMBLE NUMBER – Any simulation which may be running is ended. – The device is restarted.

Reset code	Description and effect
7864	<p>Total reset</p> <ul style="list-style-type: none"> - Affects the following parameters: <ul style="list-style-type: none"> - Function group POSITION ADJUSTMENT - Function group BASIC SETUP - Function group EXTENDED SETUP - Function group LINEARISATION (an existing linearisation table is erased) - Group OUTPUT - Function group PEAK HOLD INDICATOR - Function group HART DATA - All configurable messages ("Error" type) are set to factory setting. → See also Page 55, Section 8.1 "Messages" and Page 62, Section 8.2 "Response of outputs to errors". - Function group USER LIMITS - Function group SYSTEM 2 - Any simulation which may be running is ended. - The device is restarted.
8888	<p>HistoROM reset</p> <p>The measured value memory and event memory are cleared. During the reset, the HistoROM must be attached to the electronic insert.</p>

6 Commissioning



Warning!

- If a pressure smaller than the minimum permitted pressure is present at the device, the messages "E120 Sensor low pressure" and "E727 Sensor pressure error - overrange" are output in succession.
- If a pressure greater than the maximum permitted pressure is present at the device, the messages "E115 Sensor overpressure" and "E727 Sensor pressure error - overrange" are output in succession.
- Messages E727, E115 and E120 are "Error"-type messages and can be configured as a "Warning" or an "Alarm". These messages are configured as "Warning" messages at the factory. This setting prevents the current output from assuming the set alarm current value for applications (e.g. cascade measurement) where the user is consciously aware of the fact that the sensor range can be exceeded
- We recommend setting messages E727, E115 and E120 to "Alarm" in the following instances:
 - The sensor range does not have to be exceeded for the measuring application.
 - Position adjustment has to be carried out that has to correct a large measured error as a result of the orientation of the device (e.g. devices with a diaphragm seal).



Note!

The device is configured for the Pressure measuring mode as standard. The measuring range and the unit in which the measured value is transmitted correspond to the specifications on the nameplate.

6.1 Function check

Carry out a post-installation and a post-connection check as per the checklist before commissioning the device.

- "Post-installation check" checklist → see Section 3.4
- "Post-connection check" checklist → see Section 4.4

6.2 Selecting language and measuring mode

6.2.1 On-site operation

The LANGUAGE and MEASURING MODE parameters are located on the top menu level. → See also Page, Section 5.4.1 "General structure of the operating menu".

The following languages are available:

- Deutsch
- English
- Français
- Italiano
- Español
- Nederlands
- Chinese (CHS)
- Japanese (JPN)

The following measuring modes are available:

- Pressure
- Level

6.2.2 Digital communication

The MEASURING MODE parameter is displayed in the digital communication in the QUICK SETUP menus and in the BASIC SETUP function group (OPERATING MENU → SETTINGS → BASIC SETUP).

The following measuring modes are available:

- Pressure
- Level

The LANGUAGE parameter is arranged in the DISPLAY group (OPERATING MENU → DISPLAY).

- Use the LANGUAGE parameter to select the menu language for the on-site display.
- Select the menu language for FieldCare by means of the "Language Button" in the configuration window. Select the menu language for the FieldCare frame via the "Extra" menu → "Options" → "Display" → "Language".

The following languages are available:

- Deutsch
- English
- Français
- Italiano
- Español
- Nederlands
- Chinese (CHS)
- Japanese (JPN)

6.3 Position adjustment

Due to the orientation of the device, there may be a shift in the measured value, i.e. when the container is empty or partly filled, the measured value parameter does not display zero. There are three options to choose from when performing position adjustment.

(Menu path: (GROUP SELECTION →) OPERATING MENU → SETTINGS → POSITION ADJUSTMENT)

Parameter name	Description
POS. ZERO ADJUST (685) Entry	<p>Position adjustment – the pressure difference between zero (set point) and the measured pressure need not be known.</p> <p>Example:</p> <ul style="list-style-type: none"> – MEASURED VALUE = 2.2 mbar – Correct the MEASURED VALUE via the POS. ZERO ADJUST parameter with the "Confirm" option. This means that you are assigning the value 0.0 to the pressure present. – MEASURED VALUE (after pos. zero adjust) = 0.0 mbar – The current value is also corrected. <p>The CALIB. OFFSET parameter displays the resulting pressure difference (offset) by which the MEASURED VALUE was corrected.</p> <p>Factory setting: 0.0</p>
POS. INPUT VALUE (563) Entry	<p>Position adjustment – the pressure difference between zero (set point) and the measured pressure need not be known. To correct the pressure difference, you need a reference measurement value (e. g. from a reference device).</p> <p>Example:</p> <ul style="list-style-type: none"> – MEASURED VALUE = 0.5 mbar – For the POS. INPUT VALUE parameter, specify the desired set point for the MEASURED VALUE, e.g. 2 mbar. ($\text{MEASURED VALUE}_{\text{new}} = \text{POS. INPUT VALUE}$) – MEASURED VALUE (after entry for POS. INPUT VALUE) = 2.0 mbar – The CALIB. OFFSET parameter displays the resulting pressure difference (offset) by which the MEASURED VALUE was corrected. $\text{CALIB. OFFSET} = \text{MEASURED VALUE}_{\text{old}} - \text{POS. INPUT VALUE}$, here: $\text{CALIB. OFFSET} = 0.5 \text{ mbar} - 2.0 \text{ mbar} = -1.5 \text{ mbar}$) – The current value is also corrected. <p>Factory setting: 0.0</p>
CALIB. OFFSET (319) Entry	<p>Position adjustment – the pressure difference between zero (set point) and the measured pressure is known.</p> <p>Example:</p> <ul style="list-style-type: none"> – MEASURED VALUE = 2.2 mbar – Via the CALIB. OFFSET parameter, enter the value by which the MEASURED VALUE should be corrected. To correct the MEASURED VALUE to 0.0 mbar, you must enter the value 2.2 here. ($\text{MEASURED VALUE}_{\text{new}} = \text{MEASURED VALUE}_{\text{old}} - \text{CALIB. OFFSET}$) – MEASURED VALUE (after entry for calib. offset) = 0.0 mbar – The current value is also corrected. <p>Factory setting: 0.0</p>

6.4 Pressure measurement

6.4.1 Information on pressure measurement



Note!

- There is a Quick Setup menu for each of the measuring modes Pressure and Level which guides you through the most important basic functions. With the setting in the MEASURING MODE parameter, you specify which Quick Setup menu should be displayed. → See also Page 45, Section 6.2 "Selecting language and measuring mode".
- For a detailed description of the parameters see the Operating Instructions BA274P "Cerabar S/ Deltabar S/Deltapilot S, Description of device functions"
 - Table 6, POSITION ADJUSTMENT
 - Table 7, BASIC SETUP
 - Table 15, EXTENDED SETUP
 → See also Page 2, Section "Overview documentation".
- For pressure measurement, select the "Pressure" option by means of the MEASURING MODE parameter. The operating menu is structured appropriately. → See also Section 10.1.

6.4.2 Quick Setup menu for Pressure measuring mode

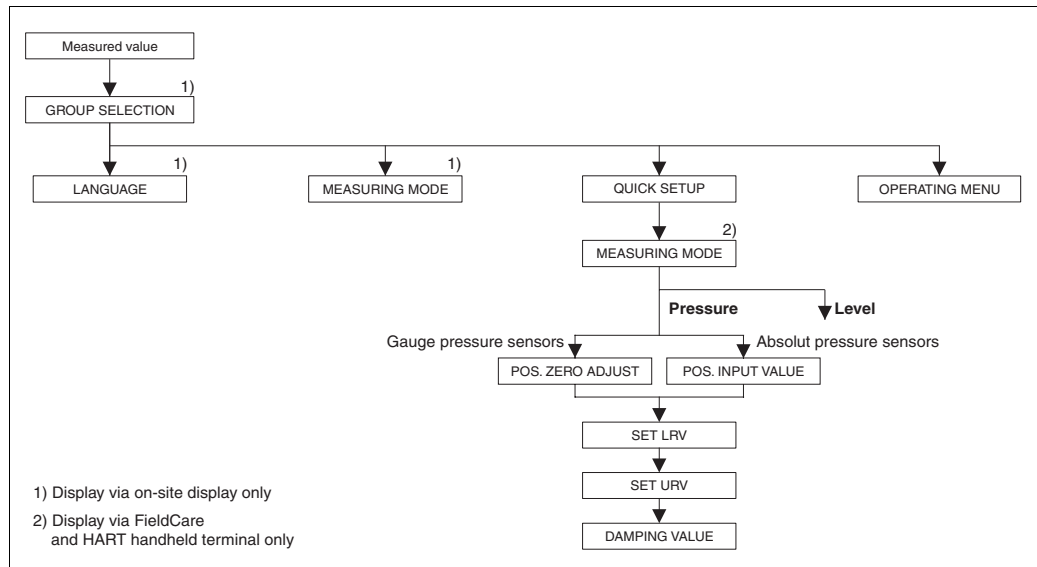

Fig. 29: Quick Setup menu for Pressure measuring mode

On-site operation
Measured value display On-site display: Switch from the measured value display to GROUP SELECTION with \square .
GROUP SELECTION Select MEASURING MODE.
MEASURING MODE Select "Pressure" option.
GROUP SELECTION Select QUICK SETUP menu.
POS. ZERO ADJUST Due to orientation of the device, there may be a shift in the measured value. You correct the MEASURED VALUE via the POS. ZERO ADJUST parameter with the "Confirm" option, i. e. you assign the value 0.0 to the pressure present.

Digital communication
Measured value display Select QUICK SETUP menu.
MEASURING MODE Select "Pressure" option.
POS. ZERO ADJUST Due to orientation of the device, there may be a shift in the measured value. You correct the MEASURED VALUE via the POS. ZERO ADJUST parameter with the "Confirm" option, i. e. you assign the value 0.0 to the pressure present.

On-site operation	Digital communication
<p>POS. INPUT VALUE Due to orientation of the device, there may be a shift in the measured value. For the POS. INPUT VALUE parameter, specify the desired set point for the MEASURED VALUE.</p>	<p>POS. INPUT VALUE Due to orientation of the device, there may be a shift in the measured value. For the POS. INPUT VALUE parameter, specify the desired set point for the MEASURED VALUE.</p>
<p>SET LRV Set the measuring range (enter 4 mA value). Specify a pressure value for the lower current value (4 mA value). A reference pressure does not have to be present at the device.</p>	<p>SET LRV Set the measuring range (enter 4 mA value). Specify a pressure value for the lower current value (4 mA value). A reference pressure does not have to be present at the device.</p>
<p>SET URV Set the measuring range (enter 20 mA value). Specify a pressure value for the upper current value (20 mA value). A reference pressure does not have to be present at the device.</p>	<p>SET URV Set the measuring range (enter 20 mA value). Specify a pressure value for the upper current value (20 mA value). A reference pressure does not have to be present at the device.</p>
<p>DAMPING TIME Enter damping time (time constant τ). The damping affects the speed at which all subsequent elements, such as the on-site display, measured value and current output react to a change in the pressure.</p>	<p>DAMPING TIME Enter damping time (time constant τ). The damping affects the speed at which all subsequent elements, such as the on-site display, measured value and current output react to a change in the pressure.</p>



Note!

For on-site operation, see also Page 31, Section 5.2.3 "Function of the operating elements" and Page 35, Section 5.4 "On-site operation".

6.5 Level measurement

6.5.1 Information on level measurement



Note!

- The Pressure and Level operating modes each have a quick setup menu which guides you through the most important basic functions. → See Page 52 for the "Level" quick setup menu.
- Furthermore, the three level modes "Level Easy Pressure", "Level Easy Height" and "Level Standard" are available to you for level measurement. You can select from the "Linear", "Pressure linearized" and "Height linearized" level types for the "Level Standard" level mode. The table in the "Overview of level measurement" section below provides an overview of the various measuring tasks.
 - In the "Level Easy Pressure" and "Level Easy Height" level modes, the values entered are not tested as extensively as in the "Level Standard" level mode. The values entered for EMPTY CALIB./FULL CALIB., EMPTY PRESSURE/FULL PRESSURE, EMPTY HEIGHT/FULL HEIGHT and SET LRV/SET URV must have a minimum interval of 1% for the "Level Easy Pressure" and "Level Easy Height" level modes. The value will be rejected with a warning message if the values are too close together. Further limit values are not checked; i.e. the values entered must be appropriate for the sensor and the measuring task so that the measuring device can measure correctly.
 - The "Level Easy Pressure" and "Level Easy Height" level modes encompass fewer parameters than the "Level Standard" mode and are used for quick and easy configuration of a level application.
 - Customer-specific units of fill level, volume and mass or a linearization table may only be entered in the "Level Standard" level mode.
 - Where the device is intended for use as a subsystem in a safety function (SIL), a "Device configuration with enhanced parameter security" (SAFETY CONFIRM.) is only possible for the "Level" operating mode in the "Level Easy Pressure" level mode. All parameters previously entered are checked after a password is entered. Once the "Level Easy Height" or "Level Standard" has been selected, the configuration will first have to be reset to the ex-works setting using the RESET parameter (menu path: (GROUP SELECTION →) OPERATING MENU → OPERATION) using the reset code "7864". → For further information see the Cerabar S (SD190P) Functional Safety Manual.
- See the Operating Instructions BA274P "Cerabar S/Deltabar S/Deltapilot S, Description of device functions". → See also Page 2, "Overview Documentation" section.

6.5.2 Overview of level measurement

Measuring task	LEVEL SELECTION/ LEVEL MODE	Measured variable options	Description	Comment	Measured value display
The measured variable is in direct proportion to the measured pressure. Calibration is performed by entering two pressure-level value pairs.	LEVEL SELECTION: Level Easy Pressure	Via OUTPUT UNIT parameter: %, level, volume or mass units.	<ul style="list-style-type: none"> – Calibration with reference pressure – wet calibration, see Operating Instructions BA274P, Section 5.2.1 – Calibration without reference pressure – dry calibration, see Operating Instructions BA274P, Section 5.2.2 	<ul style="list-style-type: none"> – Incorrect entries are possible – SIL mode possible – Customised units are not possible 	The measured value display and the LEVEL BEFORE LIN parameter show the measured value.
The measured variable is in direct proportion to the measured pressure. Calibration is performed by entering the density and two height-level value pairs.	LEVEL SELECTION: Level Easy Height	Via OUTPUT UNIT parameter: %, level, volume or mass units.	<ul style="list-style-type: none"> – Calibration with reference pressure – wet calibration, see Operating Instructions BA274P, Section 5.3.1 – Calibration without reference pressure – dry calibration, see Operating Instructions BA274P, Section 5.3.2 	<ul style="list-style-type: none"> – Incorrect entries are possible – SIL mode not possible – Customised units are not possible 	The measured value display and the LEVEL BEFORE LIN parameter show the measured value.
The measured variable is in direct proportion to the measured pressure.	LEVEL SELECTION: Level standard/ LEVEL MODE: Linear	Via LIN. MEASURAND parameter: – % (level) – Level – Volume – Mass	<ul style="list-style-type: none"> – Calibration with reference pressure – wet calibration, see Operating Instructions BA274P, Section 5.4.1 – Calibration without reference pressure – dry calibration, see Operating Instructions BA274P, Section 5.4.2 	<ul style="list-style-type: none"> – Incorrect entries are rejected by the device – SIL mode not possible – Customised level, volume and mass units are possible 	The measured value display and the LEVEL BEFORE LIN parameter show the measured value.
The measured variable is not in direct proportion to the measured pressure as, for example, with containers with a conical outlet. A linearisation table must be entered for the calibration.	LEVEL SELECTION: Level standard/ LEVEL MODE: Pressure linearized	Via LINd MEASURAND parameter: – Pressure + % – Pressure + volume – Pressure + mass	<ul style="list-style-type: none"> – Calibration with reference pressure: semiautomatic entry of linearisation table, see Operating Instructions BA274P, Section 5.5.1 – Calibration without reference pressure: manual entry of linearisation table, see Operating Instructions BA274P, Section 5.5.2 	<ul style="list-style-type: none"> – Incorrect entries are rejected by the device – SIL mode not possible – Customised level, volume and mass units are possible 	The measured value display and the TANK CONTENT parameter show the measured value.
<ul style="list-style-type: none"> – Two measured variables are required or – The container shape is given by value pairs, such as height and volume. <p>The 1st measured variable %-height or height must be in direct proportion to the measured pressure. The 2nd measured variable volume, mass or % must not be in direct proportion to the measured pressure. A linearisation table must be entered for the 2nd measured variable. The 2nd measured variable is assigned to the 1st measured variable by means of this table.</p>	LEVEL SELECTION: Level standard/ LEVEL MODE: Height linearized	Via COMB. MEASURAND parameter: – Height + volume – Height + mass – Height + % – %-Height + volume – %-Height + mass – %-Height + %	<ul style="list-style-type: none"> – Calibration with reference pressure: wet calibration and semiautomatic entry of linearisation table, see Operating Instructions BA274P, Section 5.6.1 – Calibration without reference pressure: dry calibration and manual entry of linearisation table, see Operating Instructions BA274P, Section 5.6.2 	<ul style="list-style-type: none"> – Incorrect entries are rejected by the device – SIL mode not possible – Customised level, volume and mass units are possible 	<p>The measured value display and the TANK CONTENT parameter show the 2nd measured value (volume, mass or %).</p> <p>The LEVEL BEFORE LIN parameter displays the 1st measured value (%-height or height).</p>

6.5.3 Quick Setup menu for Level measuring mode



Note!

- Some parameters are only displayed if other parameters are appropriately configured. For example, the EMPTY CALIB. parameter is only displayed in the following cases:
 - LEVEL SELECTION "Level Easy Pressure" and CALIBRATION MODE "Wet"
 - LEVEL SELECTION "Level Standard", LEVEL MODE "Linear" and CALIBRATION MODE "WET"

You can find the LEVEL MODE parameter in the BASIC SETTINGS function group (menu path: (GROUP SELECTION →) OPERATING MENU → SETTINGS → BASIC SETTINGS).

- The following parameters are set to the following values in the factory:
 - LEVEL SELECTION: Level Easy Pressure
 - CALIBRATION MODE: Wet
 - OUTPUT UNIT or LIN. MEASURAND: %
 - EMPTY CALIB.: 0.0
 - FULL CALIB.: 100.0
 - SET LRV (BASIC SETTINGS group): 0.0 (corresponds to 4 mA value)
 - SET URV (BASIC SETTINGS group): 100.0 (corresponds to 20 mA value).
- The quick setup is suitable for simple and quick commissioning. If you wish to make more complex settings, e.g. change the unit from "%" to "m", you will have to calibrate using the BASIC SETTINGS group. → See Operating Instructions BA274P or Page 2, "Overview Documentation" section.

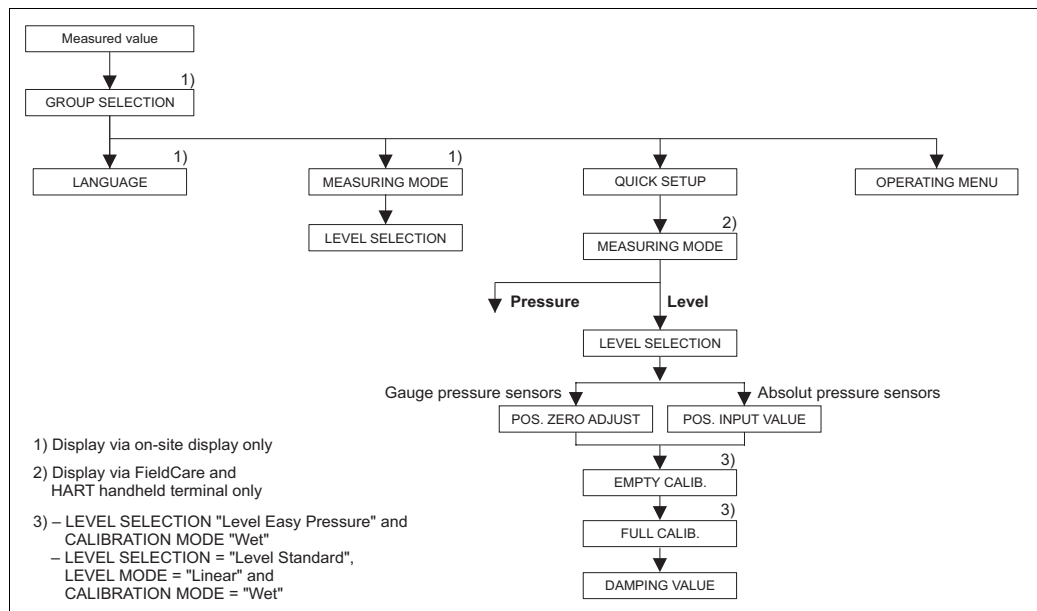

Fig. 30: Quick Setup menu for the Level measuring mode

On-site operation
Measured value display On-site display: Switch from the measured value display to GROUP SELECTION with \square .
GROUP SELECTION Select MEASURING MODE.
MEASURING MODE Select "Level" option.
LEVEL SELECTION Select level mode. For an overview see Page 51.
GROUP SELECTION Select QUICK SETUP menu.

Digital communication
Measured value display Select QUICK SETUP menu.
MEASURING MODE Select "Level" option.
LEVEL SELECTION Select level mode. For an overview see Page 51.

On-site operation	Digital communication
<p>POS. ZERO ADJUST Due to orientation of the device, there may be a shift in the measured value. You correct the MEASURED VALUE via the POS. ZERO ADJUST parameter with the "Confirm" option, i. e. you assign the value 0.0 to the pressure present.</p>	<p>POS. ZERO ADJUST Due to orientation of the device, there may be a shift in the measured value. You correct the MEASURED VALUE via the POS. ZERO ADJUST parameter with the "Confirm" option, i. e. you assign the value 0.0 to the pressure present.</p>
<p>POS. INPUT VALUE Due to orientation of the device, there may be a shift in the measured value. For the POS. INPUT VALUE parameter, specify the desired set point for the MEASURED VALUE.</p>	<p>POS. INPUT VALUE Due to orientation of the device, there may be a shift in the measured value. For the POS. INPUT VALUE parameter, specify the desired set point for the MEASURED VALUE.</p>
<p>EMPTY CALIB. ¹ Enter level for the lower calibration point. For this parameter, enter a level value which is assigned to the pressure present at the device.</p>	<p>EMPTY CALIB. ¹ Enter level for the lower calibration point. For this parameter, enter a level value which is assigned to the pressure present at the device.</p>
<p>FULL CALIB. ¹ Enter level for the upper calibration point. For this parameter, enter a level value which is assigned to the pressure present at the device.</p>	<p>FULL CALIB. ¹ Enter level for the upper calibration point. For this parameter, enter a level value which is assigned to the pressure present at the device.</p>
<p>DAMPING TIME Enter damping time (time constant τ). The damping affects the speed at which all subsequent elements, such as the on-site display, measured value and current output react to a change in the pressure.</p>	<p>DAMPING TIME Enter damping time (time constant τ). The damping affects the speed at which all subsequent elements, such as the on-site display, measured value and current output react to a change in the pressure.</p>

- 1) – LEVEL SELECTION "Level Easy Pressure" and CALIBRATION MODE "Wet"
– LEVEL SELECTION "Level Standard", LEVEL MODE "Linear" and CALIBRATION MODE "Wet"



Note!

For on-site operation, see also Page 31, Section 5.2.3 "Function of the operating elements" and Page 35, Section 5.4 "On-site operation".

7 Maintenance

Keep the pressure compensation and GORE-TEX® filter (1) free from contaminations and water.

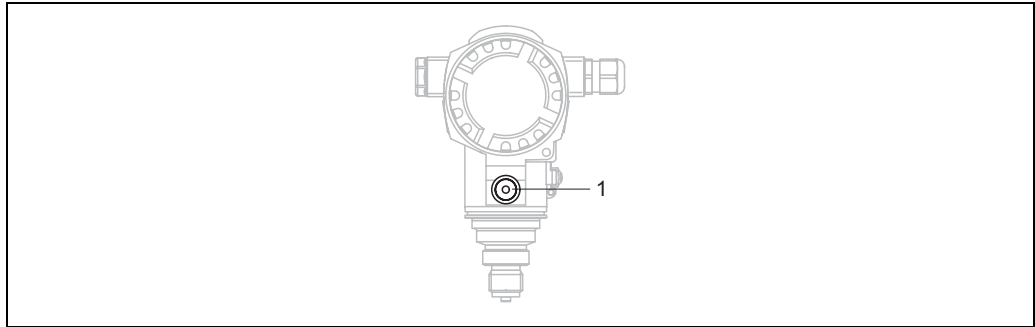

P01-PMC71:xxx-17-xx-xx-xx-001

7.1 Exterior cleaning

Please note the following points when cleaning the device:

- The cleaning agents used should not attack the surface and the seals.
- Mechanical damage to the process isolating diaphragm, e.g. due to pointed objects, must be avoided.
- Observe degree of protection. See therefor nameplate if necessary (Page 6).

8 Trouble-shooting

8.1 Messages

The following table lists all the possible messages that can occur.

The device differentiates between the error types "Alarm", "Warning" and "Error". You may specify whether the instrument should react as if for an "Alarm" or "Warning" for "Error" messages.

→ See "Error type/NA 64" column and Section 8.2 "Response of outputs to errors".

In addition, the "Error type/NA 64" column classifies the messages in accordance with NAMUR Recommendation NA 64:

- Break down: indicated with "B"
- Maintenance need: indicated with "C" (check request)
- Function check: indicated with "I" (in service)

Error message display on the on-site display:

- The measured value display shows the message with the highest priority. → See "Priority" column.
- The ALARM STATUS parameter shows all the messages present in descending order of priority. You can scroll through all the messages present with the \square -key or \square -key.

Message display via the digital communication:

- The ALARM STATUS parameter shows the message with the highest priority. → See "Priority" column.



Note!

- If the device detects a defect in the on-site display during initialization, special error messages are generated. → For the error messages, see Page 62, Section 8.1.1 "On-site display error messages".
- For support and further information, please contact Endress+Hauser Service.
- → See also Section 8.4, 8.5 and 8.6.

Code	Error type/ NA 64	Message/description	Cause	Measure	Priority
101 (A101)	Alarm B	B>Sensor electronic EEPROM error	<ul style="list-style-type: none"> – Electromagnetic effects are greater than specifications in the technical data. (→ See Section 9.) This message normally only appears briefly. – Sensor defect. 	<ul style="list-style-type: none"> – Wait a few minutes. – Restart the device. Perform reset (Code 62). – Block off electromagnetic effects or eliminate source of disturbance. – Replace sensor. 	17
102 (W102)	Warning C	C>Checksum error in EEPROM: peakhold segment	<ul style="list-style-type: none"> – Main electronics defect. Correct measurement can continue as long as you do not need the peak hold indicator function. 	<ul style="list-style-type: none"> – Replace main electronics. 	53
106 (W106)	Warning C	C>Downloading - please wait	<ul style="list-style-type: none"> – Downloading. 	<ul style="list-style-type: none"> – Wait for download to complete. 	52
110 (A110)	Alarm B	B>Checksum error in EEPROM: configuration segment	<ul style="list-style-type: none"> – The supply voltage is disconnected when writing. – Electromagnetic effects are greater than specifications in the technical data. (→ See Section 9.) – Main electronics defect. 	<ul style="list-style-type: none"> – Reestablish supply voltage. Perform reset (Code 7864) if necessary. Carry out calibration again. – Block off electromagnetic effects or eliminate sources of disturbance. – Replace main electronics. 	6
113 (A113)	Alarm B	B>ROM failure in transmitter electronic	<ul style="list-style-type: none"> – Main electronics defect. 	<ul style="list-style-type: none"> – Replace main electronics. 	1

Code	Error type/ NA 64	Message/description	Cause	Measure	Priority
115 (E115)	Error B factory setting: Warning	B>Sensor overpressure	<ul style="list-style-type: none"> – Overpressure present. – Sensor defect. 	<ul style="list-style-type: none"> – Reduce pressure until message disappears. – Replace sensor. 	29
116 (W116)	Warning C	C>Download error, repeat download	<ul style="list-style-type: none"> – The file is defect. – During the download, the data are not correctly transmitted to the processor, e.g. because of open cable connections, spikes (ripple) on the supply voltage or electromagnetic effects. 	<ul style="list-style-type: none"> – Use another file. – Check cable connection PC – transmitter. – Block off electromagnetic effects or eliminate sources of disturbance. – Perform reset (Code 7864) and carry out calibration again. – Repeat download. 	36
120 (E120)	Error B factory setting: Warning	B>Sensor low pressure	<ul style="list-style-type: none"> – Pressure too low. – Sensor defect. 	<ul style="list-style-type: none"> – Increase pressure until message disappears. – Replace sensor. 	30
121 (A121)	Alarm B	B>Checksum error in factory segment of EEPROM	<ul style="list-style-type: none"> – Main electronics defect. 	<ul style="list-style-type: none"> – Replace main electronics. 	5
122 (A122)	Alarm B	B>Sensor not connected	<ul style="list-style-type: none"> – Cable connection sensor –main electronics disconnected. – Electromagnetic effects are greater than specifications in the technical data. (→ See Section 9.) – Main electronics defect. – Sensor defect. 	<ul style="list-style-type: none"> – Check cable connection and repair if necessary. – Block off electromagnetic effects or eliminate source of disturbance. – Replace main electronics. – Replace sensor. 	13
130 (A130)	Alarm B	B>EEPROM is defect.	<ul style="list-style-type: none"> – Main electronics defect. 	<ul style="list-style-type: none"> – Replace main electronics. 	10
131 (A131)	Alarm B	B>Checksum error in EEPROM: min/max segment	<ul style="list-style-type: none"> – Main electronics defect. 	<ul style="list-style-type: none"> – Replace main electronics. 	9
132 (A132)	Alarm B	B>Checksum error in totalizer EEPROM	<ul style="list-style-type: none"> – Main electronics defect. 	<ul style="list-style-type: none"> – Replace main electronics. 	7
133 (A133)	Alarm B	B>Checksum error in History EEPROM	<ul style="list-style-type: none"> – An error occurred when writing. – Main electronics defect. 	<ul style="list-style-type: none"> – Perform reset (Code 7864) and carry out calibration again. – Replace electronics. 	8
602 (W602)	Warning C	C>Linearisation curve not monoton	<ul style="list-style-type: none"> – The linearisation table is not monotonic increasing or decreasing. 	<ul style="list-style-type: none"> – Add to linearisation table or perform linearisation again. 	57
613 (W613)	Warning I	I>Simulation is active	<ul style="list-style-type: none"> – Simulation is switched on, i.e. the device is not measuring at present. 	<ul style="list-style-type: none"> – Switch off simulation. 	60
620 (E620)	Error C Factory setting: Warning	C>Current output out of range	<ul style="list-style-type: none"> The current is outside the permitted range 3.8 to 20.5 mA. – The pressure applied is outside the set measuring range (but within the sensor range). – Loose connection at sensor cable 	<ul style="list-style-type: none"> – Check pressure applied, reconfigure measuring range if necessary (→ See also Operating Instructions BA274P, chapter 4 to 6 or these Operating Instructions, Page 2.) – Perform reset (Code 7864) and carry out calibration again. – Wait a short period of time and tighten the connection, or avoid loose connection. 	49
700 (W700)	Warning C	C>Last configuration not stored	<ul style="list-style-type: none"> – An error occurred when writing or reading configuration data or the power supply was disconnected. – Main electronics defect. 	<ul style="list-style-type: none"> – Perform reset (Code 7864) and carry out calibration again. – Replace main electronics. 	54

Code	Error type/ NA 64	Message/description	Cause	Measure	Priority
701 (W701)	Warning C	C>Measuring chain config. exceeds sensor range	<ul style="list-style-type: none"> – The calibration carried out would result in the sensor nominal operating range being undershot or overshoot. 	<ul style="list-style-type: none"> – Carry out calibration again. 	50
702 (W702)	Warning C	C>HistoROM data not consistent.	<ul style="list-style-type: none"> – Data were not written correctly to the HistoROM, e.g. if the HistoROM was detached during the writing process. – HistoROM does not have any data. 	<ul style="list-style-type: none"> – Repeat upload. – Perform reset (Code 7864) and carry out calibration again. – Copy suitable data to the HistoROM. (→ See also Page 38, Section 5.5.1 "Copying configuration data".) 	55
703 (A703)	Alarm B	B>Measurement error	<ul style="list-style-type: none"> – Fault in the main electronics. – Main electronics defect. 	<ul style="list-style-type: none"> – Briefly disconnect device from the power supply. – Replace main electronics. 	22
704 (A704)	Alarm B	B>Measurement error	<ul style="list-style-type: none"> – Fault in the main electronics. – Main electronics defect. 	<ul style="list-style-type: none"> – Briefly disconnect device from the power supply. – Replace main electronics. 	12
705 (A705)	Alarm B	B>Measurement error	<ul style="list-style-type: none"> – Fault in the main electronics. – Main electronics defect. 	<ul style="list-style-type: none"> – Briefly disconnect device from the power supply. – Replace main electronics. 	21
706 (W706)	Warning C	C>Configuration in HistoROM and device not identical	<ul style="list-style-type: none"> – Configuration (parameters) in the HistoROM and in the device is not identical. 	<ul style="list-style-type: none"> – Copy data from the device to the HistoROM. (→ See also Page 38, Section 5.5.1 "Copying configuration data".) – Copy data from the HistoROM to the device. (→ See also Page 38, Section 5.5.1 "Copying configuration data".) The message remains if the HistoROM and the device have different software versions. The message goes out if you copy the data from the device to the HistoROM. – Device reset codes such as 7864 do not have any effect on the HistoROM. That means that if you do a reset, the configurations in the HistoROM and in the device may not be the same. 	59
707 (A707)	Alarm B	B>X-VAL. of lin. table out of edit limits.	<ul style="list-style-type: none"> – At least one X-VALUE in the linearisation table is either below the value for HYDR. PRESS MIN. or MIN. LEVEL or above the value for HYDR. PRESS. MAX. or LEVEL MAX. 	<ul style="list-style-type: none"> – Carry out calibration again. (→ See also Operating Instructions BA274P, chapter 5 or these Operating Instructions, Page 2.) 	38
710 (W710)	Warning C	B>Set span too small. Not allowed.	<ul style="list-style-type: none"> – Values for calibration (e.g. lower range value and upper range value) are too close together. – The sensor was replaced and the customer-specific configuration does not suit the sensor. – Unsuitable download carried out. 	<ul style="list-style-type: none"> – Adjust calibration to suit sensor. (→ See also Operating Instructions BA274P, parameter description MINIMUM SPAN or these Operating Instructions, Page 2.) – Adjust calibration to suit sensor. – Replace sensor with a suitable sensor. – Check configuration and perform download again. 	51

Code	Error type/ NA 64	Message/description	Cause	Measure	Priority
711 (A711)	Alarm B	B>LRV or URV out of edit limits	<ul style="list-style-type: none"> - Lower range value and/or upper range value undershoot or overshoot the sensor range limits. - The sensor was replaced and the customer-specific configuration does not suit the sensor. - Unsuitable download carried out. 	<ul style="list-style-type: none"> - Reconfigure lower range value and/or upper range value to suit the sensor. Pay attention to position factor. - Reconfigure lower range value and/or upper range value to suit the sensor. Pay attention to position factor. - Replace sensor with a suitable sensor. - Check configuration and perform download again. 	37
713 (A713)	Alarm B	B>100% POINT level out of edit limits	<ul style="list-style-type: none"> - The sensor was replaced. 	<ul style="list-style-type: none"> - Carry out calibration again. 	39
715 (E715)	Error C Factory setting: Warning	C>Sensor over temperature	<ul style="list-style-type: none"> - The temperature measured in the sensor is greater than the upper nominal temperature of the sensor. (→ See also Operating Instructions BA274P, parameter description Tmax SENSOR or these Operating Instructions, Page 2.) - Unsuitable download carried out. 	<ul style="list-style-type: none"> - Reduce process temperature/ ambient temperature. - Check configuration and perform download again. 	32
716 (E716)	Error B Factory setting: Alarm	B>Process isolating diaphragm broken	<ul style="list-style-type: none"> - Sensor defect. 	<ul style="list-style-type: none"> - Replace Sensor. - Reduce pressure. 	24
717 (E717)	Error C Factory setting: Warning	C>Transmitter over temperature	<ul style="list-style-type: none"> - The temperature measured in the electronics is greater than the upper nominal temperature of the electronics (+88 °C). - Unsuitable download carried out. 	<ul style="list-style-type: none"> - Reduce ambient temperature. - Check configuration and perform download again. 	34
718 (E718)	Error C Factory setting: Warning	C>Transmitter under temperature	<ul style="list-style-type: none"> - The temperature measured in the electronics is smaller than the lower nominal temperature of the electronics (-43 °C). - Unsuitable download carried out. 	<ul style="list-style-type: none"> - Increase ambient temperature. Insulate device if necessary. - Check configuration and perform download again. 	35
719 (A719)	Alarm B	B>Y-VAL of lin. table out of edit limits	<ul style="list-style-type: none"> - At least on Y-VALUE in the linearisation table is below the MIN. TANK CONTENT or above the MAX. TANK CONTENT. 	<ul style="list-style-type: none"> - Carry out calibration again. (→ See also Operating Instructions BA274P, chapter 5 or these Operating Instructions, Page 2.) 	40
720 (E720)	Error C Factory setting: Warning	C>Sensor under temperature	<ul style="list-style-type: none"> - The temperature measured in the sensor is smaller than the lower nominal temperature of the sensor. (→ See also Operating Instructions BA274P, parameter description Tmin SENSOR or Operating Instructions, Page 2.) - Unsuitable download carried out. - Loose connection at sensor cable 	<ul style="list-style-type: none"> - Increase process temperature/ ambient temperature. - Check configuration and perform download again. - Wait a short period of time and tighten the connection, or avoid loose connection. 	33
721 (A721)	Alarm B	B>ZERO POSITION level out of edit limits	<ul style="list-style-type: none"> - LEVEL MIN or LEVEL MAX has been changed. 	<ul style="list-style-type: none"> - Perform reset (Code 2710) and carry out calibration again. 	41

Code	Error type/ NA 64	Message/description	Cause	Measure	Priority
722 (A722)	Alarm B	B>EMPTY CALIB. or FULL CALIB. out of edit limits	– LEVEL MIN or LEVEL MAX has been changed.	– Perform reset (Code 2710) and carry out calibration again.	42
723 (A723)	Alarm B	B>MAX. FLOW out of edit limits	– FLOW-MEAS. TYPE has been changed.	– Carry out calibration again.	43
725 (A725)	Alarm B	B>Sensor connection error, cycle disturbance	– Electromagnetic effects are greater than specifications in the technical data. (→ See Section 9.) – Sensor or main electronics defect.	– Block off electromagnetic effects or eliminate source of disturbance. – Replace sensor or main electronics.	25
726 (E726)	Error C Factory setting: Warning	C>Sensor temperature error - overrange	– Electromagnetic effects are greater than specifications in the technical data. (→ See Section 9.) – Process temperature is outside permitted range. – Sensor defect.	– Block off electromagnetic effects or eliminate source of disturbance. – Check temperature present, reduce or increase if necessary. – If the process temperature is within the permitted range, replace sensor.	31
727 (E727)	Error C Factory setting: Warning	C>Sensor pressure error - overrange	– Electromagnetic effects are greater than specifications in the technical data. (→ See Section 9.) – Pressure is outside permitted range. – Sensor defect.	– Block off electromagnetic effects or eliminate source of disturbance. – Check pressure present, reduce or increase if necessary. – If the pressure is within the permitted range, replace sensor.	28
728 (A728)	Alarm B	B>RAM error	– Fault in the main electronics. – Main electronics defect.	– Briefly disconnect device from the power supply. – Replace main electronics.	2
729 (A729)	Alarm B	B>RAM error	– Fault in the main electronics. – Main electronics defect.	– Briefly disconnect device from the power supply. – Replace main electronics.	3
730 (E730)	Error C Factory setting: Warning	C>LRV user limits exceeded	– Pressure measured value has undershot the value specified for the Pmin ALARM WINDOW parameter. – Loose connection at sensor cable	– Check system/pressure measured value. – Change value for Pmin ALARM WINDOW if necessary. (→ See also Operating Instructions BA274P, parameter description Pmin ALARM WINDOW or these Operating Instructions, Page 2.) – Wait a short period of time and tighten the connection, or avoid loose connection.	46
731 (E731)	Error C Factory setting: Warning	C>URV user limits exceeded	– Pressure measured value has overshoot the value specified for the Pmax ALARM WINDOW parameter. – Loose connection at sensor cable	– Check system/pressure measured value. – Change value for Pmax ALARM WINDOW if necessary. (→ See also Operating Instructions BA274P, parameter description Pmax ALARM WINDOW or these Operating Instructions, Page 2.) – Wait a short period of time and tighten the connection, or avoid loose connection.	45

Code	Error type/ NA 64	Message/description	Cause	Measure	Priority
732 (E732)	Error C Factory setting: Warning	C>LRV Temp. User limits exceeded	<ul style="list-style-type: none"> – Temperature measured value has undershot the value specified for the Tmin ALARM WINDOW parameter. 	<ul style="list-style-type: none"> – Check system/temperature measured value. – Change value for Tmin ALARM WINDOW if necessary. (→ See also Operating Instructions BA274P, parameter description Tmin ALARM WINDOW or these Operating Instructions, Page 2.) 	48
733 (E733)	Error C Factory setting: Warning	C>URV Temp. User limits exceeded	<ul style="list-style-type: none"> – Temperature measured value has overshoot the value specified for the Tmax ALARM WINDOW parameter. 	<ul style="list-style-type: none"> – Check system/temperature measured value. – Change value for Tmax ALARM WINDOW if necessary. (→ See also Operating Instructions BA274P, parameter description Tmax ALARM WINDOW or these Operating Instructions, Page 2.) 	47
736 (A736)	Alarm B	B>RAM error	<ul style="list-style-type: none"> – Fault in the main electronics. – Main electronics defect. 	<ul style="list-style-type: none"> – Briefly disconnect device from the power supply. – Replace main electronics. 	4
737 (A737)	Alarm B	B>Measurement error	<ul style="list-style-type: none"> – Fault in the main electronics. – Main electronics defect. 	<ul style="list-style-type: none"> – Briefly disconnect device from the power supply. – Replace main electronics. 	20
738 (A738)	Alarm B	B>Measurement error	<ul style="list-style-type: none"> – Fault in the main electronics. – Main electronics defect. 	<ul style="list-style-type: none"> – Briefly disconnect device from the power supply. – Replace main electronics. 	19
739 (A739)	Alarm B	B>Measurement error	<ul style="list-style-type: none"> – Fault in the main electronics. – Main electronics defect. 	<ul style="list-style-type: none"> – Briefly disconnect device from the power supply. – Replace main electronics. 	23
740 (E740)	Error C Factory setting: Warning	C>Calculation overflow, bad configuration	<ul style="list-style-type: none"> – Level measuring mode: the measured pressure has undershot the value for HYDR. PRESS. MIN. or overshoot the value for HYDR. PRESS MAX. – Level measuring mode: The measured level did not reach the LEVEL MIN value or exceeded the LEVEL MAX value. – Flow measuring mode: the measured pressure has undershot the value for MAX. PRESS FLOW. 	<ul style="list-style-type: none"> – Check configuration and carry out calibration again if necessary. – Select a device with a suitable measuring range. – Check configuration and carry out calibration again if necessary. (→ See also Operating Instructions BA274P, parameter description LEVEL MIN. these Operating Instructions, Page 2.) – Check configuration and carry out calibration again if necessary. – Select a device with a suitable measuring range. 	27
741 (A741)	Alarm B	B>TANK HEIGHT out of edit limits	<ul style="list-style-type: none"> – LEVEL MIN or LEVEL MAX has been changed. 	<ul style="list-style-type: none"> – Perform reset (Code 2710) and carry out calibration again. 	44
742 (A742)	Alarm B	B>Sensor connection error (upload)	<ul style="list-style-type: none"> – Electromagnetic effects are greater than specifications in the technical data. (→ See Section 9.) This message normally only appears briefly. – Cable connection sensor –main electronics disconnected. – Sensor defect. 	<ul style="list-style-type: none"> – Wait a few minutes. – Perform reset (Code 7864) and carry out calibration again. – Check cable connection and repair if necessary. – Replace sensor. 	18
743 (E743)	Alarm B	B>Electronic PCB error during initialisation	<ul style="list-style-type: none"> – This message normally only appears briefly. – Main electronics defect. 	<ul style="list-style-type: none"> – Wait a few minutes. – Restart the device. Perform reset (Code 62). – Replace main electronics. 	14

Code	Error type/ NA 64	Message/description	Cause	Measure	Priority
744 (A744)	Alarm B	B>Main electronic PCB error	<ul style="list-style-type: none"> - Electromagnetic effects are greater than specifications in the technical data. (→ See Section 9.) - Main electronics defect. 	<ul style="list-style-type: none"> - Restart the device. Perform reset (Code 62). - Block off electromagnetic effects or eliminate source of disturbance. - Replace main electronics. 	11
745 (W745)	Warning C	C>Sensor data unknown	<ul style="list-style-type: none"> - Sensor does not suit the device (electronic sensor nameplate). Device continues measuring. 	<ul style="list-style-type: none"> - Replace sensor with a suitable sensor. 	56
746 (W746)	Warning C	C>Sensor connection error - initialising	<ul style="list-style-type: none"> - Electromagnetic effects are greater than specifications in the technical data. (→ See Section 9.) This message normally only appears briefly. - Overpressure or low pressure present. 	<ul style="list-style-type: none"> - Wait a few minutes. - Restart the device. Perform reset (Code 7864). - Block off electromagnetic effects or eliminate source of disturbance. - Reduce or increase pressure. 	26
747 (A747)	Alarm B	B>Sensor software not compatible to electronics	<ul style="list-style-type: none"> - Sensor does not suit the device (electronic sensor nameplate). 	<ul style="list-style-type: none"> - Replace sensor with a suitable sensor. 	16
748 (A748)	Alarm B	B>Memory failure in signal processor	<ul style="list-style-type: none"> - Electromagnetic effects are greater than specifications in the technical data. (→See Section 9.) - Main electronics defect. 	<ul style="list-style-type: none"> - Block off electromagnetic effects or eliminate source of disturbance. - Replace main electronics. 	15



8.1.1 On-site display error messages

If the device detects a defect in the on-site display during initialization, the following error messages can be displayed:

Message	Measure
Initialization, VU Electr. Defect A110	Exchange on-site display.
Initialization, VU Electr. Defect A114	
Initialization, VU Electr. Defect A281	
Initialization, VU Checksum Err. A110	
Initialization, VU Checksum Err. A112	
Initialization, VU Checksum Err. A171	

8.2 Response of outputs to errors

The device differentiates between the error types Alarm, Warning and Error.
 → See the following table and Page 55, Section 8.1 "Messages".

Output	A (Alarm)	W (Warning)	E (Error: Alarm/Warning)
Current output	Assumes the value specified via the OUTPUT FAIL MODE ¹ , ALT. CURR. OUTPUT ¹ and SET MAX. ALARM ¹ parameter. → See also the following section "Configuring current output for an alarm".	Device continues measuring.	For this error, you can enter whether the device should react as in the event of an alarm or as in the event of a warning. See corresponding "Alarm" or "Warning" column. (→ See also Operating Instructions BA274P, parameter description SELECT ALARM TYPE or these Operating Instructions, Page 2.)
Bargraph (on-site display)	The bargraph adopts the value defined by the OUTPUT FAIL MODE ¹ parameter.	The bargraph adopts the value which corresponds to the current value.	→ See this table, "Alarm" or "Warning" column, depending on selection.
On-site display	<ul style="list-style-type: none"> The measured value and message are displayed alternately Measured value display: -symbol is permanently displayed. <p>Message display</p> <ul style="list-style-type: none"> 3-digit number such as A122 and description 	<ul style="list-style-type: none"> The measured value and message are displayed alternately Measured value display: -symbol flashes. <p>Message display:</p> <ul style="list-style-type: none"> 3-digit number such as W613 and description 	<ul style="list-style-type: none"> The measured value and message are displayed alternately Measured value display: see corresponding "Alarm" or "Warning" column <p>Message display:</p> <ul style="list-style-type: none"> 3-digit number such as E731 and description
Remote operation (digital communication)	In the case of an alarm, the ALARM STATUS ² parameter displays a 3-digit number such as 122 for "Sensor not connected".	In the case of a warning, the ALARM STATUS ² parameter displays a 3-digit number such as 613 for "Simulation is active".	In the case of an error, the ALARM STATUS ² parameter displays a 3-digit number such as 731 for "URV user limits exceeded".

- 1) Menu path: (GROUP SELECTION →) OPERATING MENU → OUTPUT
- 2) Menu path: (GROUP SELECTION →) OPERATING MENU → MESSAGES

8.2.1 Configuring current output for an alarm

You can configure the current output for the event of an alarm by means of the OUTPUT FAIL MODE, ALT. CURR. OUTPUT and SET MAX. ALARM parameters. These parameters are displayed in the OUTPUT group (menu path: (GROUP SELECTION →) OPERATING MENU → OUTPUT).

In the event of an alarm, the current and the bargraph assume the value entered with the OUTPUT FAIL MODE parameter.

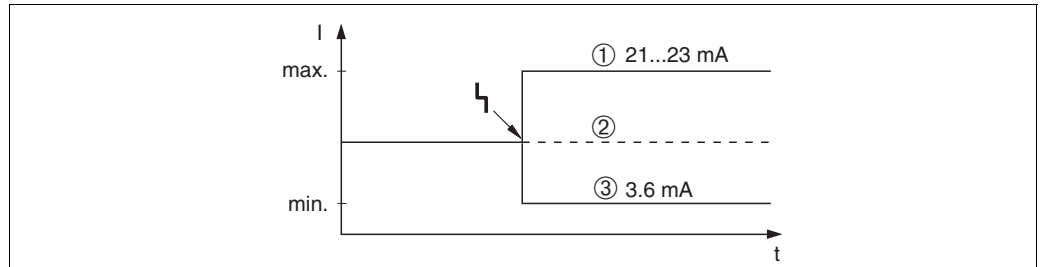

Fig. 31: Current output in the event of an alarm

Options:

- 1 Max. alarm (110%): can be set between 21 to 23 mA via the SET MAX. ALARM parameter
- 2 Hold meas. value: last measured value is kept
- 3 Min. alarm (-10%): 3.6 mA

Factory setting:

- OUTPUT FAIL MODE: Max. Alarm (110%)
- SET MAX. ALARM: 22 mA

Use the ALT. CURR. OUTPUT parameter to set the current output value for the error messages E 120 "Sensor low pressure" and E 115 "Sensor overpressure". You have the following options:

- Normal: the current output assumes the value set via the OUTPUT FAIL MODE and SET MAX. ALARM parameters.
- NAMUR
 - Lower sensor limit undershot (E 120 "Sensor low pressure"): 3.6 mA
 - Upper sensor limit overshoot (E 115 "Sensor overpressure") overshoot: current output assumes the value set via the SET MAX ALARM parameter.

Factory setting:

- ALT. CURR. OUTPUT: normal



8.3 Confirming messages

Depending on the settings for the ALARM DISPL. TIME and ACK. ALARM MODE parameters, the following measures should be taken to clear a message:

Settings ¹	Measures
<ul style="list-style-type: none"> - ALARM DISPL. TIME = 0 s - ACK. ALARM MODE = off 	<ul style="list-style-type: none"> - Rectify cause of the message (see also Section 8.1).
<ul style="list-style-type: none"> - ALARM DISPL. TIME > 0 s - ACK. ALARM MODE = off 	<ul style="list-style-type: none"> - Rectify cause of the message (see also Section 8.1). - Wait for the alarm display time to elapse.
<ul style="list-style-type: none"> - ALARM DISPL. TIME = 0 s - ACK. ALARM MODE = on 	<ul style="list-style-type: none"> - Rectify cause of the message (see also Section 8.1). - Confirm message using ACK. ALARM parameter.
<ul style="list-style-type: none"> - ALARM DISPL. TIME > 0 s - ACK. ALARM MODE = on 	<ul style="list-style-type: none"> - Rectify cause of the message (see also Section 8.1). - Confirm message using ACK. ALARM parameter. - Wait for the alarm display time to elapse. If a message appears and the alarm display time elapses before the message has been acknowledged, the message will be cleared once it has been acknowledged.

1) Menu path for ALARM DISPL. TIME and ACK. ALARM MODE: (GROUP SELECTION →) OPERATING MENU → DIAGNOSTICS → MESSAGES

If the on-site display displays a message, you can suppress it with the -key.

If there are several messages, the on-site display shows the message which has the highest priority (see also Section 8.1). Once you have suppressed this message using the -key, the message with the next highest priority is displayed. You can use the -key to suppress each message, one after the other.

The ALARM STATUS parameter continues to display all the messages present.

8.4 Repair

The Endress+Hauser repairs concept provides for measuring devices to have a modular design and also the customer may carry out repairs (see Chap. 8.6 "Spare Parts" on Page 66).



Note!

- For certified devices, please consult Chapter "Repair of Ex-certified devices".
- For more information on service and spare parts contact the Endress+Hauser Service. → See www.endress.com/worldwide.

8.5 Repair of Ex-certified devices



Warning!

When repairing Ex-certified devices, please note the following:

- Only specialist personnel or Endress+Hauser may undertake repairs of certified devices.
- Relevant standards, national hazardous area regulations and Safety Instructions and Certificates must be observed.
- Only genuine Endress+Hauser spare parts may be used.
- When ordering spare parts, please check the device designation on the nameplate. Identical parts may only be used as replacements.
- Electronic inserts or sensors already in use in a standard instrument may not be used as spare parts for a certified device.
- Carry out repairs according to the instructions. After repairs, the device must fulfil the requirements of the specified individual tests.
- A certified device may only be converted into another certified variant by Endress+Hauser.
- All repairs and modifications must be documented.

8.6 Spare Parts

An overview of the spare parts for your device is available in the internet at www.endress.com. To obtain information on the spare parts, proceed as follows:

1. Go to "www.endress.com" and select your country.
2. Click "Instruments".

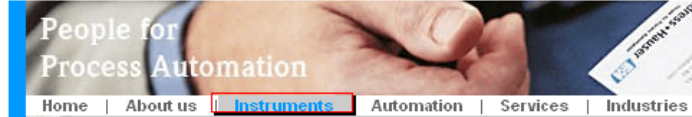

3. Enter the product name into the "product name" field.

Endress+Hauser product search

Via product name
 Enter the product name

4. Select the device.
5. Click the "Accessories/Spare parts" tab.

General information	Technical information	Documents/ Software	Service	Accessories/ Spare parts
---------------------	-----------------------	---------------------	---------	---------------------------------

▶ Accessories
 ▼ All Spare parts

- ▶ Housing/housing accessories
- ▶ Sealing
- ▶ Cover
- ▶ Terminal module
- ▶ HF module
- ▶ Electronic
- ▶ Power supply
- ▶ Antenna module



Advice
 Here you'll find a list of all available accessories and spare parts. To only view accessories and spare parts specific to your product(s), please contact us and ask about our Life Cycle Management Service.

◀ | 1 / 2 | ▶ | 🔍

6. Select the required spare parts (You may also use the overview drawing on the right side of the screen.)

When ordering spare parts, always quote the serial number indicated on the nameplate. As far as necessary, the spare parts also include replacement instructions.

8.7 Returning the device

Before you send in a device for repairs or checking:

- Remove all signs of fluids, paying particular attention to seal grooves and gaps in which fluid can become lodged. This is especially important if the fluid is hazardous to health. Please refer also to the "Declaration of Hazardous Material and De-Contamination".

Please enclose the following when returning the device:

- Please fill out completely and sign the "Declaration of Hazardous Material and De-Contamination".

It is only then possible for Endress+Hauser to inspect or repair the returned device.

- The chemical and physical properties of the fluid.
- A description of the application.
- A description of the error which occurred.
- Special instructions on handling, if necessary, e.g. safety data sheet as per EN 91/155/EEC.

8.8 Disposal

When disposing, separate and recycle the device components based on the materials.

8.9 Software history

Date	Software version	Changes software	Documentation		
			CD-ROM	Operating Instructions	Description of Instrument Functions
11.2003	01.00.zz	Original software. Compatible with: – ToF Tool Field Tool Package, version 1.04.00 or higher – Commuwin II version 2.08.-1, Update G or higher – HART Communicator 375 with Device Rev.: 10, DD Rev.: 1	—	BA271P/00/EN/10.03 52020517	—
06.2004	02.00.zz	– Number of parameters in the Quick Setup menus has been reduced. – On-site operation: LANGUAGE and MEASURING MODE parameters have been moved to the top level. – New SAFETY CONFIRM. group implemented for SIL. → See also SD190P Safety Manual Cerabar S. – MEASURING MODE "Level", LEVEL MODE "Linear": AREA UNIT and TANK SECTION parameters have been replaced with the TANK VOLUME and TANK HEIGHT parameters. – Function of the UNIT FLOW parameter has been split across four parameters. – Function of the SIMULATED VALUE parameter has been split across six parameters. – SENSOR TRIM and CURRENT TRIM groups have been removed. – Sensor adapt reset, code 1209 and sensor calibration reset, code 2509 have been removed. – Quick Setup menus are available via ToF Tool. Compatible with: – ToF Tool Field Tool Package version 2.00.00 or higher – Commuwin II version 2.08.-1, Update > G – HART Communicator 375 with Device Rev.: 20, DD Rev.: 1	—	BA271P/00/EN/05.04 52022795	BA274P/00/EN/05.04 52021469
06.2005	02.01.zz	– Operating keys also integrated on the optional on-site display. – Chinese and Japanese are available as the menu language on request. Compatible with: – ToF Tool Field Tool Package version 3.00.00 or higher – FieldCare version 2.01.00, DTM Library version 2.06.00, DTM: Deltabar S/MD7x/V02.00 V 1.4.98.74* – HART Communicator 375 with Device Rev.: 20, DD Rev.: 1* * Menu languages Chinese and Japanese not selectable	—	BA271P/00/EN/06.05 71000115	BA274P/00/EN/05.04 52021469
			—	BA271P/00/EN/11.05 71009589	BA274P/00/EN/05.04 52021469

Date	Software version	Changes software	Documentation		
			CD-ROM	Operating Instructions	Description of Instrument Functions
06.2006	02.10.zz	<ul style="list-style-type: none"> – New "Level Easy Pressure" and "Level Easy Height" level modes implemented. New LEVEL SELECTION parameter implemented. – OPERATION group with DOWNLOAD SELECT parameter extended. – SAFETY CONFIRM group extended for the "Level" operating mode in the "Level Easy Pressure" level selection. → See also SD190P Safety Manual Cerabar S. – Factory setting for the "Error" messages redefined. – Chinese and Japanese included as menu languages by default. Compatible with: <ul style="list-style-type: none"> – ToF Tool Field Tool Package version 4.0 – FieldCare version 2.02.00 – HART Communicator 375 with Device Rev.: 21, DD Rev.: 1 	—	BA271P/00/EN/07.06 71027246	BA274P/00/EN/07.06 71027249
			—	BA271P/00/EN/08.06 71027246	BA274P/00/EN/07.06 71027249
			CD507P/00/A2/10.07 71033931	BA271P/00/EN/10.07 71043296	BA274P/00/EN/07.07 71061022
			CD507P/00/A2/12.07 71033931	BA271P/00/EN/12.07 71043296	BA274P/00/EN/07.07 71061022
			CD507P/00/A2/05.08 71071801	BA271P/00/EN/05.08 71071770	BA274P/00/EN/05.08 71071855
			CD507P/00/A2/08.08 71077559	BA271P/00/EN/08.08 71077544	BA274P/00/EN/05.08 71071855
			CD507P/00/A2/06.09 71095448	BA271P/00/EN/06.09 71095434	BA274P/00/EN/06.09 71095452

9 Technical data

For technical data, please refer to the Technical Information Cerabar S TI383P (PMC71, PMP71, PMP75); TI438P (PMP72). → See also Page 2, Section "Overview documentation".

10 Appendix

10.1 Operating menu for on-site display, FieldCare and HART handheld terminal



Note!

- The entire menu is depicted on the following pages.
- The menu has a different structure depending on the measuring mode selected. This means that some function groups are only displayed for one measuring mode, e.g. "LINEARISATION" function group for the Level measuring mode.
- In addition, there are also parameters that are only displayed if other parameters are appropriately configured. For example the Customer Unit P parameter is only displayed if the "User unit" option was selected for the PRESS. ENG. UNIT parameter. These parameters are indicated with a "*".
- For a description of the parameters, please refer to Operating Instructions BA274P "Description of device functions". The exact dependency of individual parameters on one another is explained here. See also Page 2, Section "Overview documentation".

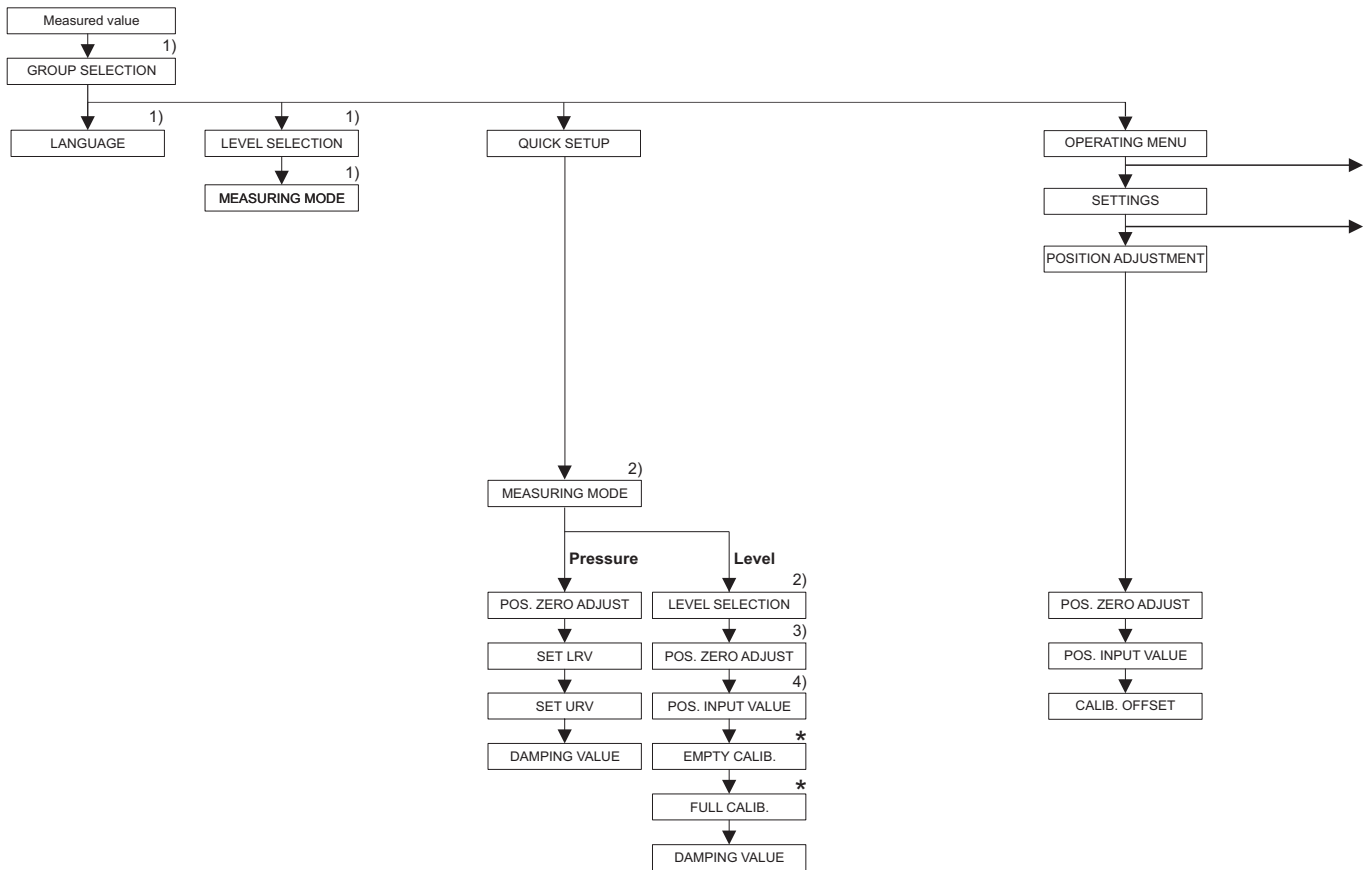

1) Display via on-site display only

2) Display via FieldCare and HART Handheld terminal only

* There are parameters that are only displayed if other parameters are appropriately configured. For example the CUSTOMER UNIT P parameter is only displayed if the "User unit" option was selected for the PRESS. ENG. UNIT parameter. These parameters are indicated with a "*".

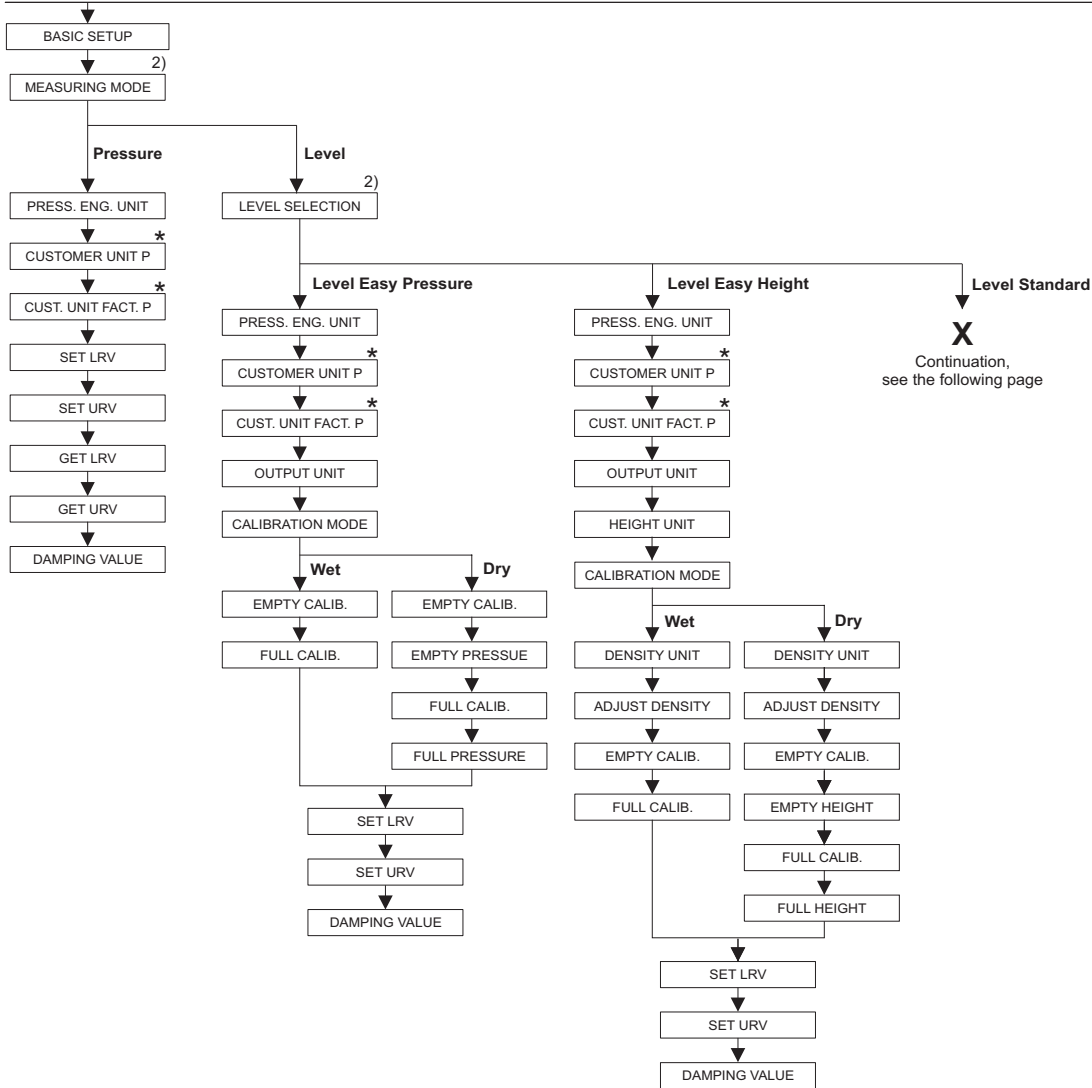

2) Display via FieldCare and HART Handheld terminal only

* There are parameters that are only displayed if other parameters are appropriately configured. For example the CUSTOMER UNIT P parameter is only displayed if the "User unit" option was selected for the PRESS. ENG. UNIT parameter. These parameters are indicated with a "*".

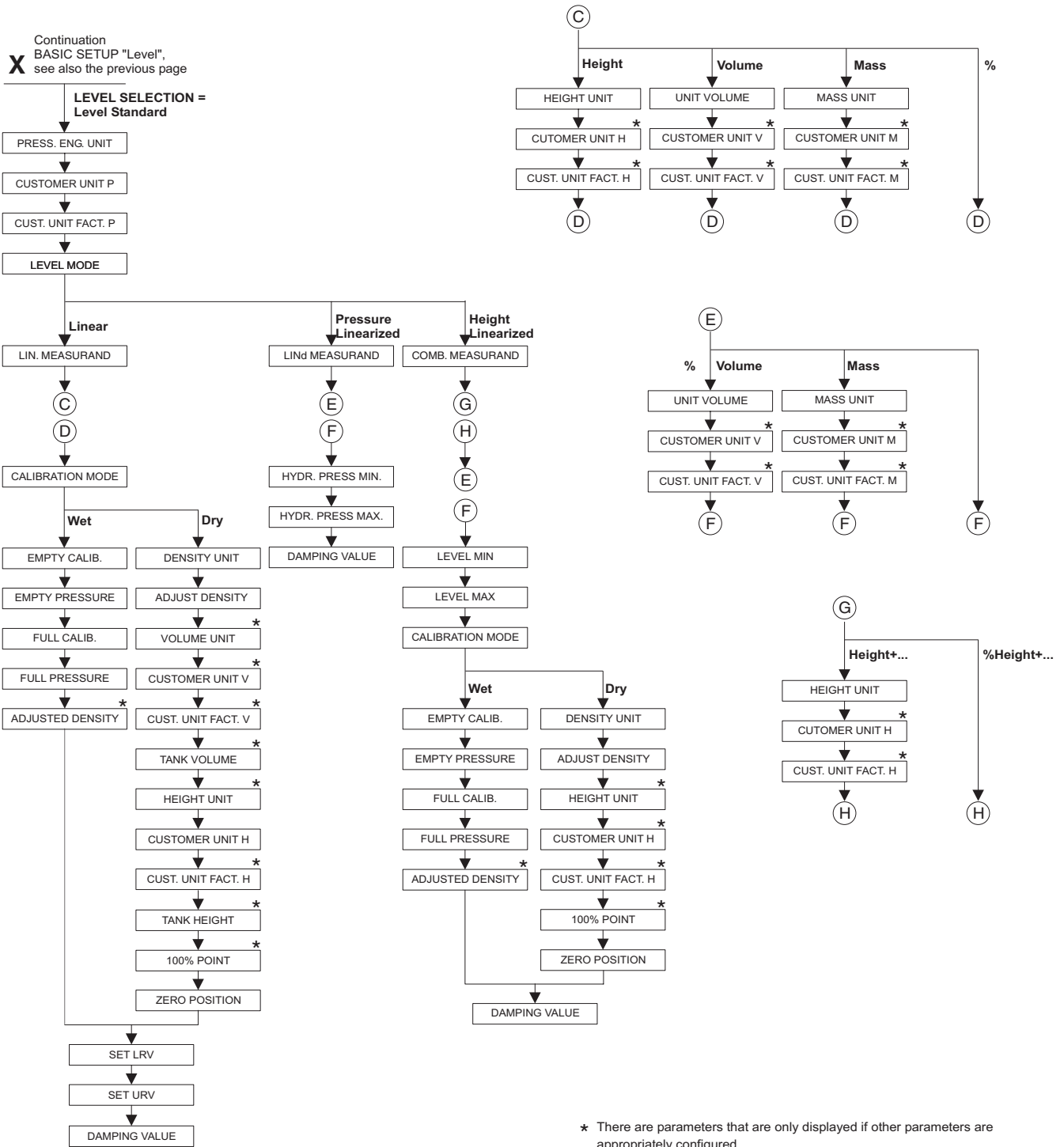

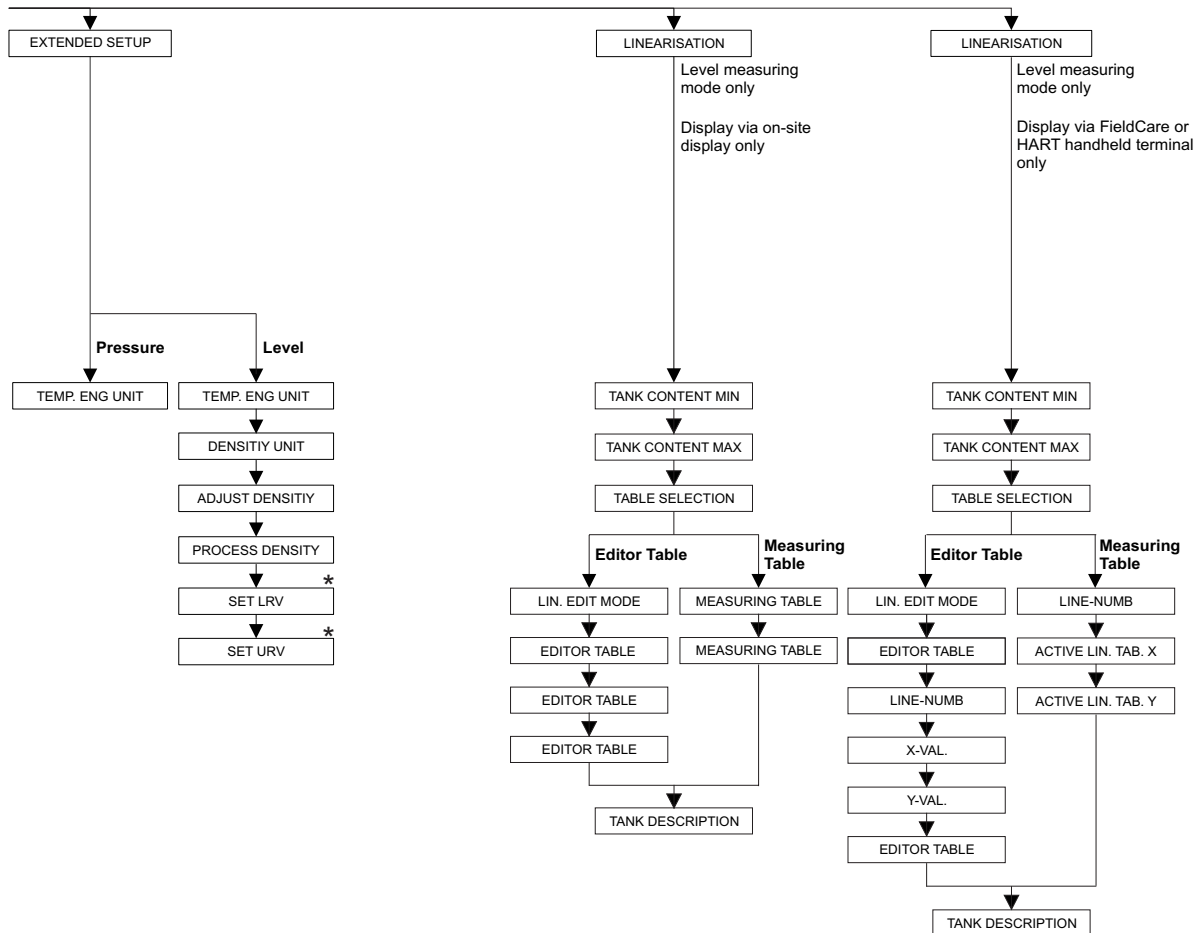

* There are parameters that are only displayed if other parameters are appropriately configured. These parameters are indicated with a "*".

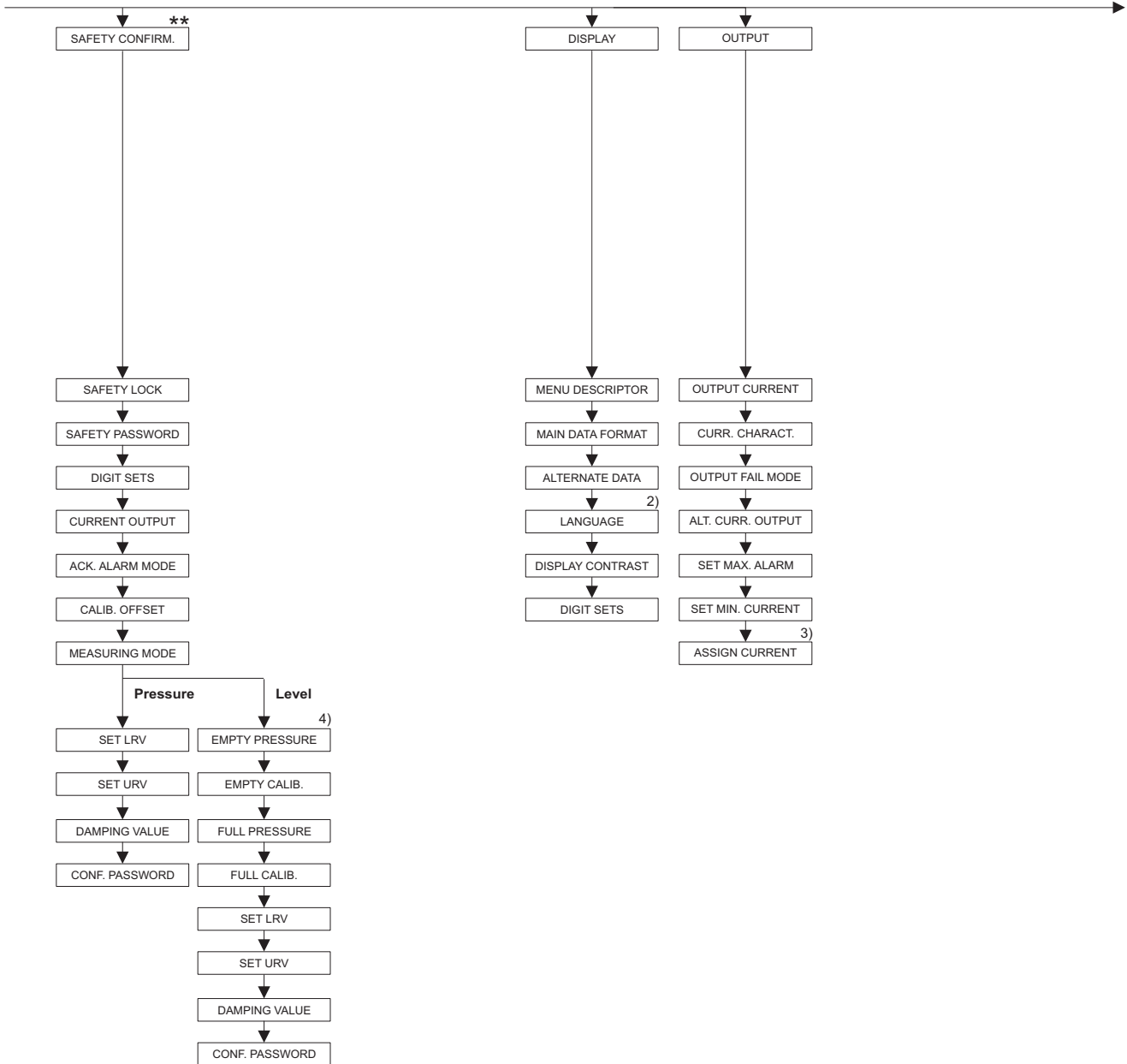

2) Display via HART handheld terminal only

3) Level measuring mode only

4) only LEVEL SELECTION = Level Easy Pressure

* There are parameters that are only displayed if other parameters are appropriately configured. These parameters are indicated with a "*".

** See Safety Manual SD190P.

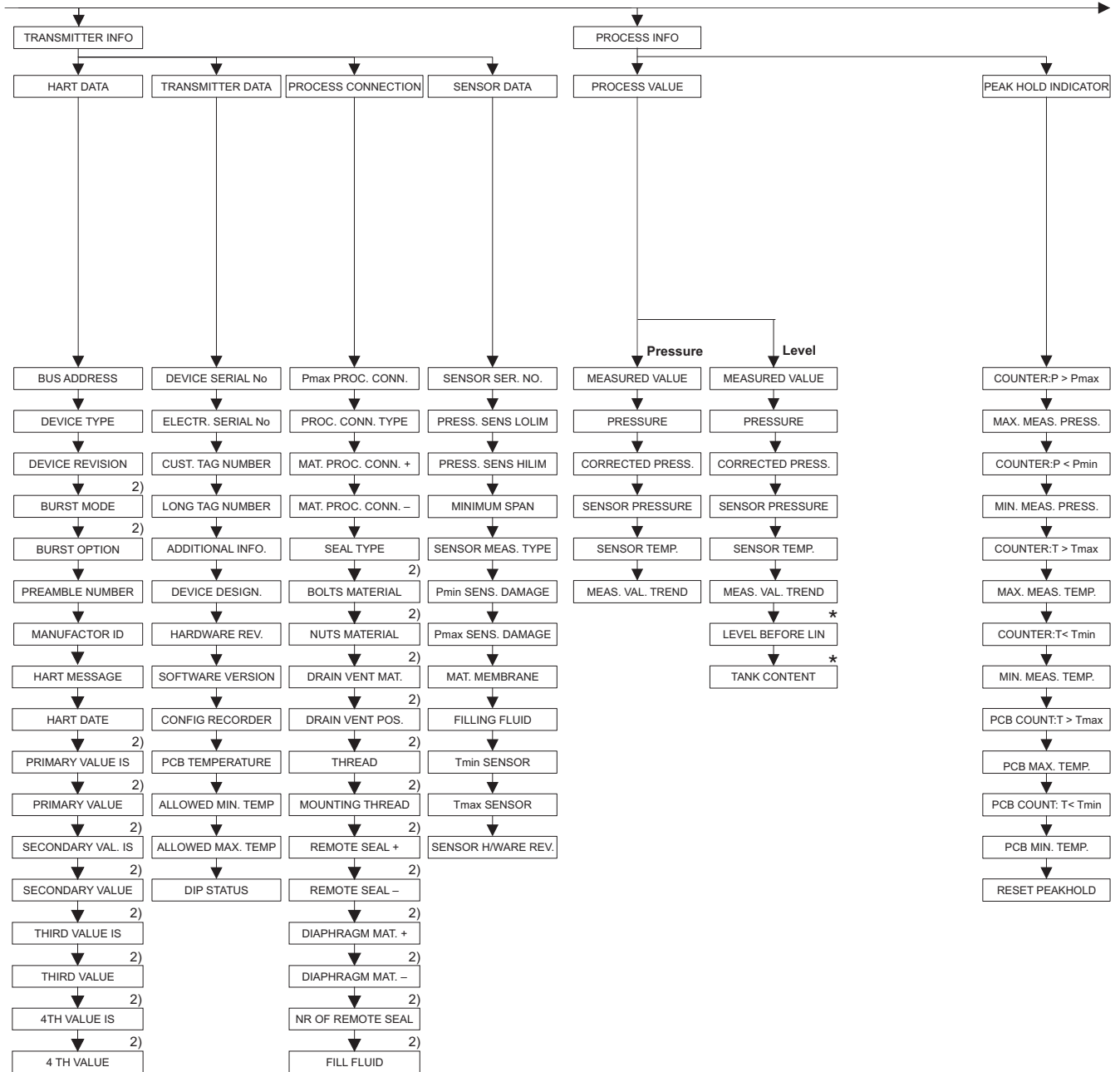

2) Display via FieldCare and HART handheld terminal only

* There are parameters that are only displayed if other parameters are appropriately configured. These parameters are indicated with a "*".

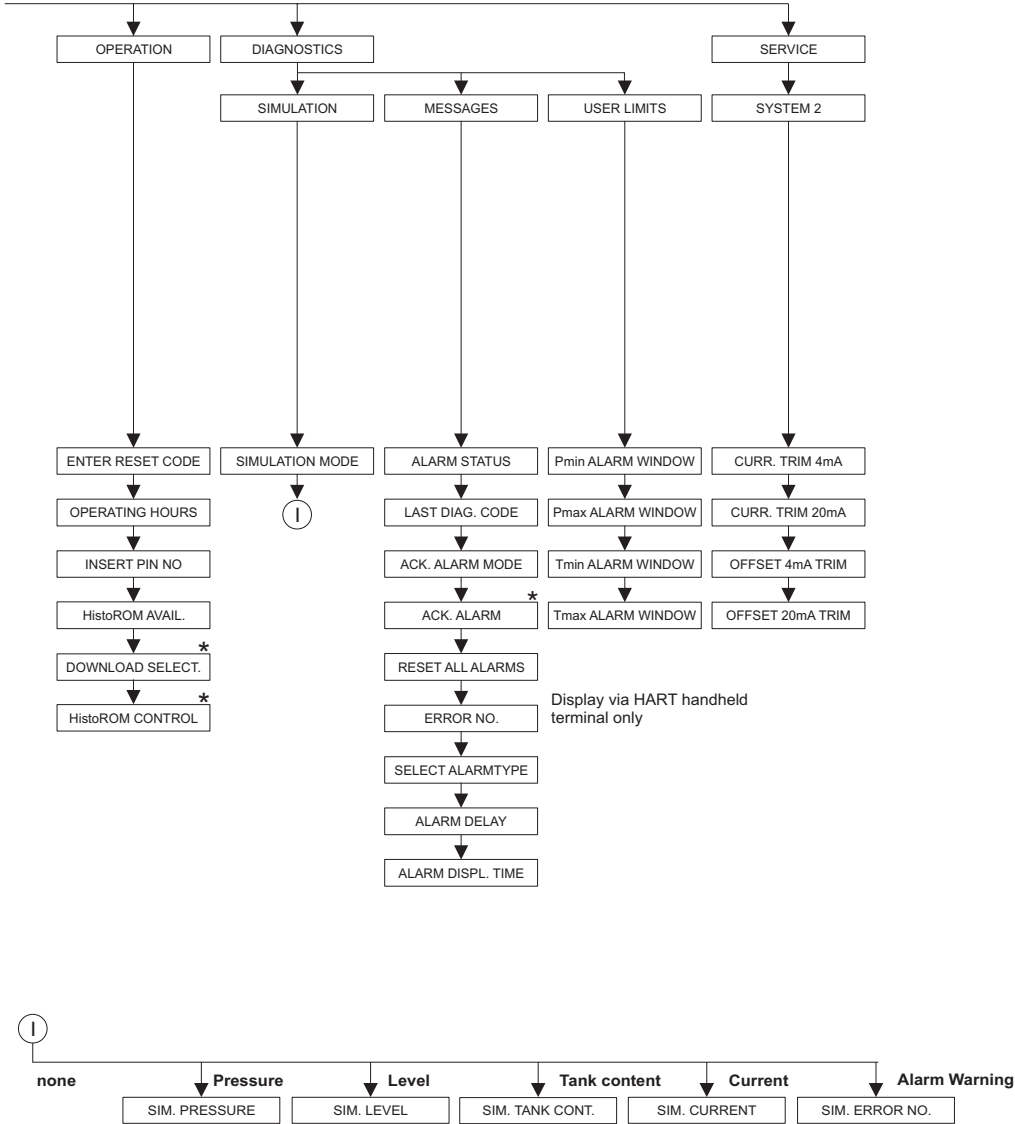

* There are parameters that are only displayed if other parameters are appropriately configured. These parameters are indicated with a "**".

10.2 Patents

This product may be protected by at least one of the following patents. Further patents are pending.

- US 5,836,063 A1 \cong EP 0 797 084 B1
- US 5,877,424 A1 \cong EP 0 780 674 B1
- DE 203 05 869 U1
- US 6,363,790 A1 \cong EP 0 995 979 B1
- US 5,670,063 A1 \cong EP 0 516 579 B1
- US 5,539,611 A1
- US 5,050,034 A1 \cong EP 0 445 382 B1
- US 5,005,421 A1 \cong EP 0 351 701 B1
- EP 0 414 871 B1
- EP 1 061 351 B1
- US 5,334,344 A1 \cong EP 0 490 807 B1
- US 6,703,943 A1

Index

Numerics

4...20 mA test signal. 22

A

Alarm messages 55

C

Cable specification 22

Commubox FXA191, connection 25

Commubox FXA195, connection 25

Connecting Commubox FXA291 26

Connecting ToF Adapter FXA291 26

D

Diaphragm seals, installation instructions 13

Diaphragm seals, vacuum application 14

Display. 28

E

Electrical connection 20

Error messages 55

Ersatzteile 66

F

Factory setting 43

FieldCare 41

H

HART handheld terminal, connection 24

Hazardous areas 4

Heat insulation. 16

HistoROM/M-DAT 37

I

Incoming acceptance 10

Installation instructions for devices with diaphragm seals. . 13

Installation instructions for devices without diaphragm seals . . 11

L

Language, selection 45

Level measurement 50–51

Level measurement, Quick Setup menu 52

Load 23

Locking operation. 42

M

Measuring arrangement for level measurement 13

Measuring arrangement for pressure measurement . . . 11–12

Measuring mode, selection 45

N

Nameplate 6

O

On-site display 28

Operating elements, function, with on-site display 31

Operating elements, position 29

Operating keys, function, without on-site display. 30

Operating keys, position 29

Operating menu 35, 70

Overvoltage protection 27

P

Pipe mounting 16

Position adjustment 47

Potential matching 23, 26

Pressure measurement 48

Pressure measurement, Quick Setup menu 48

Q

Quick Setup menu level 52

Quick Setup menu pressure 48

R

Repair. 65

Repair of Ex-certified devices 65

Reset 43

Rotating the housing. 19

S

Scope of delivery. 9

Screening 23

Separate housing, assemble and mount 17

Service Interface FXA291 26

SIL3 4

Software history 68

Storage. 10

Supply voltage 22

T

Temperature isolator, installation instructions 14

Trouble-shooting 55

U

Unlocking operation 42

W

Wall mounting 16

Warnings 55

Welding recommendation. 18

Declaration of Hazardous Material and De-Contamination

Erklärung zur Kontamination und Reinigung

RA No.

Please reference the Return Authorization Number (RA#), obtained from Endress+Hauser, on all paperwork and mark the RA# clearly on the outside of the box. If this procedure is not followed, it may result in the refusal of the package at our facility.

Bitte geben Sie die von E+H mitgeteilte Rücklieferungsnummer (RA#) auf allen Lieferpapieren an und vermerken Sie diese auch außen auf der Verpackung. Nichtbeachtung dieser Anweisung führt zur Ablehnung ihrer Lieferung.

Because of legal regulations and for the safety of our employees and operating equipment, we need the "Declaration of Hazardous Material and De-Contamination", with your signature, before your order can be handled. Please make absolutely sure to attach it to the outside of the packaging.

Aufgrund der gesetzlichen Vorschriften und zum Schutz unserer Mitarbeiter und Betriebseinrichtungen, benötigen wir die unterschriebene "Erklärung zur Kontamination und Reinigung", bevor Ihr Auftrag bearbeitet werden kann. Bringen Sie diese unbedingt außen an der Verpackung an.

Type of instrument / sensor

Geräte-/Sensortyp _____

Serial number

Seriennummer _____

Used as SIL device in a Safety Instrumented System / Einsatz als SIL Gerät in Schutzzeineinrichtungen

Process data / Prozessdaten

Temperature / Temperatur _____ [°F] _____ [°C]

Pressure / Druck _____ [psi] _____ [Pa]

Conductivity / Leitfähigkeit _____ [µS/cm]

Viscosity / Viskosität _____ [cp] _____ [mm²/s]

Medium and warnings

Warnhinweise zum Medium



	Medium / concentration Medium / Konzentration	Identification CAS No.	flammable entzündlich	toxic giftig	corrosive ätzend	harmful/ irritant gesundheitsschädlich/ reizend	other * sonstiges*	harmless unbedenklich
Process medium Medium im Prozess								
Medium for process cleaning Medium zur Prozessreinigung								
Returned part cleaned with Medium zur Endreinigung								

* explosive; oxidising; dangerous for the environment; biological risk; radioactive

* explosiv; brandfördernd; umweltgefährlich; biogefährlich; radioaktiv

Please tick should one of the above be applicable, include safety data sheet and, if necessary, special handling instructions.

Zutreffendes ankreuzen; trifft einer der Warnhinweise zu, Sicherheitsdatenblatt und ggf. spezielle Handhabungsvorschriften beilegen.

Description of failure / Fehlerbeschreibung _____

Company data / Angaben zum Absender

Company / Firma _____	Phone number of contact person / Telefon-Nr. Ansprechpartner: _____
Address / Adresse _____	Fax / E-Mail _____
_____	Your order No. / Ihre Auftragsnr. _____

"We hereby certify that this declaration is filled out truthfully and completely to the best of our knowledge. We further certify that the returned parts have been carefully cleaned. To the best of our knowledge they are free of any residues in dangerous quantities."

"Wir bestätigen, die vorliegende Erklärung nach unserem besten Wissen wahrheitsgetreu und vollständig ausgefüllt zu haben. Wir bestätigen weiter, dass die zurückgesandten Teile sorgfältig gereinigt wurden und nach unserem besten Wissen frei von Rückständen in gefährlicher Menge sind."

(place, date / Ort, Datum)

Name, dept./Abt. (please print / bitte Druckschrift)

Signature / Unterschrift

www.endress.com/worldwide

Endress+Hauser 
People for Process Automation

BA271P/00/EN/06.09
71095434
CCS/FM+SGML6.0

