

**Features**

- 1-channel signal conditioner
- Universal usage at different power supplies
- Input for 2- or 3-wire sensors, NAMUR sensors or dry contacts
- Input frequency 1 mHz ... 12 kHz
- Current output 0/4 mA ... 20 mA
- Relay and transistor output
- Start-up override
- Line fault detection (LFD)
- Up to SIL2 acc. to IEC 61508/IEC 61511

**Function**

This signal conditioner provides the isolation for non-intrinsically safe applications.

The device is a universal frequency converter that changes a digital input signal into a proportional free adjustable 0/4 mA ... 20 mA analog output signal and functions as a switch amplifier and a trip alarm.

The functions of the switch outputs (2 relay outputs and 1 potential free transistor output) are easily adjustable [trip value display (min/max alarm), serially switched output, pulse divider output, error signal output].

The device is easily configured by the use of keypad or with the PACTware configuration software.

A fault is signaled by LEDs acc. to NAMUR NE44.

For additional information, refer to the manual and [www.pepperl-fuchs.com](http://www.pepperl-fuchs.com).

**Assembly**

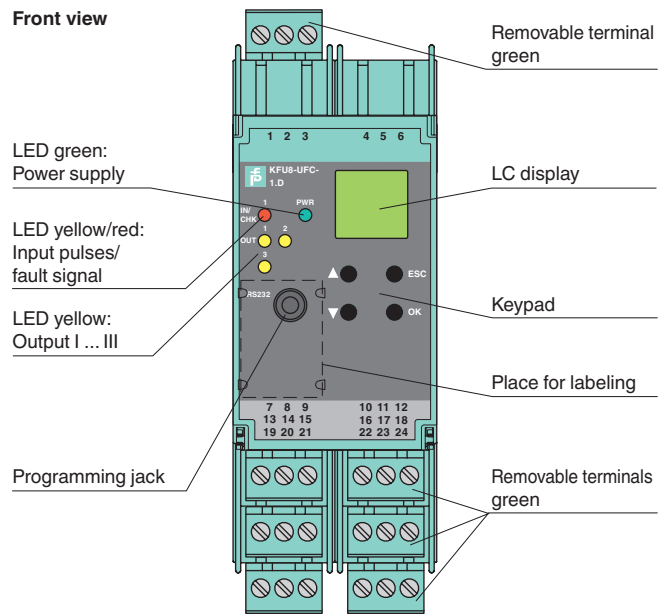

**SIL 2**

**Connection**

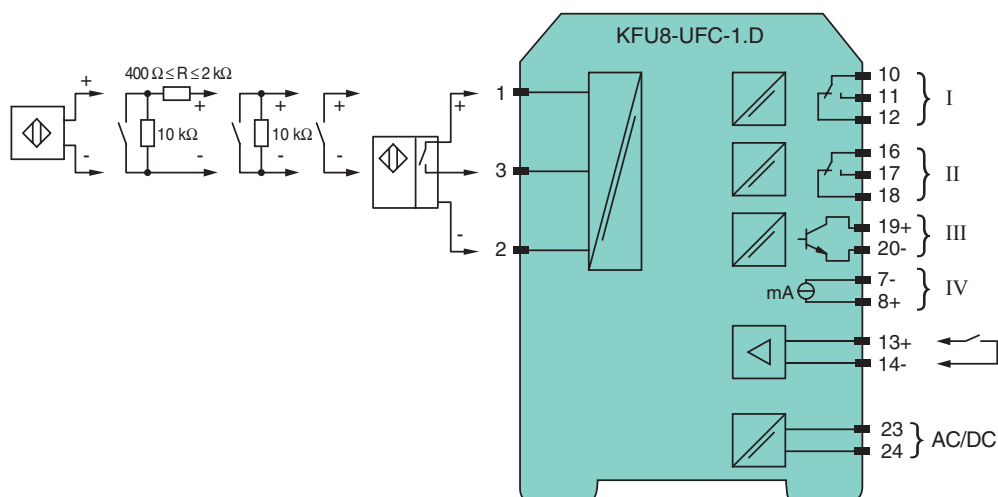

Release date 2016-04-18 11:12 Date of issue 2016-04-18 231195\_eng.xml

Refer to "General Notes Relating to Pepperl+Fuchs Product Information".

Pepperl+Fuchs Group  
www.pepperl-fuchs.com

USA: +1 330 486 0002  
pa-info@us.pepperl-fuchs.com

Germany: +49 621 776 2222  
pa-info@de.pepperl-fuchs.com

Singapore: +65 6779 9091  
pa-info@sg.pepperl-fuchs.com

<b>General specifications</b>	
Signal type	Digital Input
<b>Supply</b>	
Connection	terminals 23, 24
Rated voltage $U_n$	20 ... 90 V DC / 48 ... 253 V AC 50 ... 60 Hz
Power dissipation/power consumption	$\leq 2 \text{ W}$ ; 2.5 VA / 2.2 W ; 3 VA
<b>Input</b>	
Connection	Input I: 2-wire sensor: terminals 1+, 3- three wire sensor: terminals 1+, 2- and 3 input II: terminals 13+, 14- start-up override;
Input I	2- or 3-wire sensor, sensor acc. to EN 60947-5-6 (NAMUR) or mechanical contact
Open circuit voltage/short-circuit current	22 V / 40 mA
Input resistance	4.7 k $\Omega$
Switching point/switching hysteresis	logic 1: $> 2.5 \text{ mA}$ ; logic 0: $< 1.9 \text{ mA}$
Pulse duration	$> 50 \mu\text{s}$
Input frequency	0.001 ... 12000 Hz
Lead monitoring	breakage I $\leq 0.15 \text{ mA}$ ; short-circuit I $> 4 \text{ mA}$
Input II	startup override: 1 ... 1000 s, adjustable in steps of 1 s
Active/Passive	I $> 4 \text{ mA}$ (for min. 100 ms) / I $< 1.5 \text{ mA}$
Open circuit voltage/short-circuit current	18 V / 5 mA
<b>Output</b>	
Connection	output I: terminals 10, 11, 12 output II: terminals 16, 17, 18 output III: terminals 19+, 20- output IV: terminals 8+, 7-
Output I, II	signal, relay
Contact loading	250 V AC / 2 A / $\cos \phi \geq 0.7$ ; 40 V DC / 2 A
Mechanical life	$5 \times 10^7$ switching cycles
Energized/De-energized delay	approx. 20 ms / approx. 20 ms
Output III	electronic output, passive
Contact loading	40 V DC
Signal level	1-signal: (L+) -2.5 V (50 mA, short-circuit/overload proof) 0-signal: blocked output (off-state current $\leq 10 \mu\text{A}$ )
Output IV	analog
Current range	0 ... 20 mA or 4 ... 20 mA
Open loop voltage	$\leq 24 \text{ V DC}$
Load	$\leq 650 \Omega$
Fault signal	downscale I $\leq 3.6 \text{ mA}$ , upscale $\geq 21.5 \text{ mA}$ (acc. NAMUR NE43)
<b>Transfer characteristics</b>	
Input I	
Measurement range	0.001 ... 12000 Hz
Resolution	0.1 % of the measurement value , $\geq 0.001 \text{ Hz}$
Accuracy	0.1 % of the measurement value , $> 0.001 \text{ Hz}$
Measuring time	$< 100 \text{ ms}$
Influence of ambient temperature	0.003 %/K (30 ppm)
Output I, II	
Response delay	$\leq 200 \text{ ms}$
Output IV	
Resolution	$< 10 \mu\text{A}$
Accuracy	$< 20 \mu\text{A}$
Influence of ambient temperature	0.005 %/K (50 ppm)
<b>Electrical isolation</b>	
Input I/other circuits	reinforced insulation according to IEC/EN 61010-1, rated insulation voltage 300 V <sub>eff</sub>
Output I, II/other circuits	reinforced insulation according to IEC/EN 61010-1, rated insulation voltage 300 V <sub>eff</sub>
Mutual output I, II, III	reinforced insulation according to IEC/EN 61010-1, rated insulation voltage 300 V <sub>eff</sub>
Output III/power supply	reinforced insulation according to IEC/EN 61010-1, rated insulation voltage 300 V <sub>eff</sub>
Output III/IV	basic insulation according to IEC/EN 61010-1, rated insulation voltage 50 V <sub>eff</sub>
Output IV/power supply	reinforced insulation according to IEC/EN 61010-1, rated insulation voltage 300 V <sub>eff</sub>
Start-up override/power supply	reinforced insulation according to IEC/EN 61010-1, rated insulation voltage 300 V <sub>eff</sub>
Interface/power supply	reinforced insulation according to IEC/EN 61010-1, rated insulation voltage 300 V <sub>eff</sub>
Interface/output III	basic insulation according to IEC/EN 61010-1, rated insulation voltage 50 V <sub>eff</sub>
<b>Directive conformity</b>	
Electromagnetic compatibility	
Directive 2004/108/EC	EN 61326-1:2006
Low voltage	

Release date 2016-04-18 11:12 Date of issue 2016-04-18 231195\_eng.xml

Refer to "General Notes Relating to Pepperl+Fuchs Product Information".

Pepperl+Fuchs Group  
www.pepperl-fuchs.com

USA: +1 330 486 0002  
pa-info@us.pepperl-fuchs.com

Germany: +49 621 776 2222  
pa-info@de.pepperl-fuchs.com

Singapore: +65 6779 9091  
pa-info@sg.pepperl-fuchs.com

Directive 2006/95/EC	EN 61010-1:2010
<b>Conformity</b>	
Electromagnetic compatibility	NE 21:2006
Degree of protection	IEC 60529:2001
<b>Ambient conditions</b>	
Ambient temperature	-20 ... 60 °C (-4 ... 140 °F)
<b>Mechanical specifications</b>	
Degree of protection	IP20
Mass	300 g
Dimensions	40 x 119 x 115 mm (1.6 x 4.7 x 4.5 in) , housing type C3
Mounting	on 35 mm DIN mounting rail acc. to EN 60715:2001
<b>General information</b>	
Supplementary information	Statement of Conformity, Declaration of Conformity, Attestation of Conformity and instructions have to be observed where applicable. For information see <a href="http://www.pepperl-fuchs.com">www.pepperl-fuchs.com</a> .

### Maximum Switching Power of Output Contacts

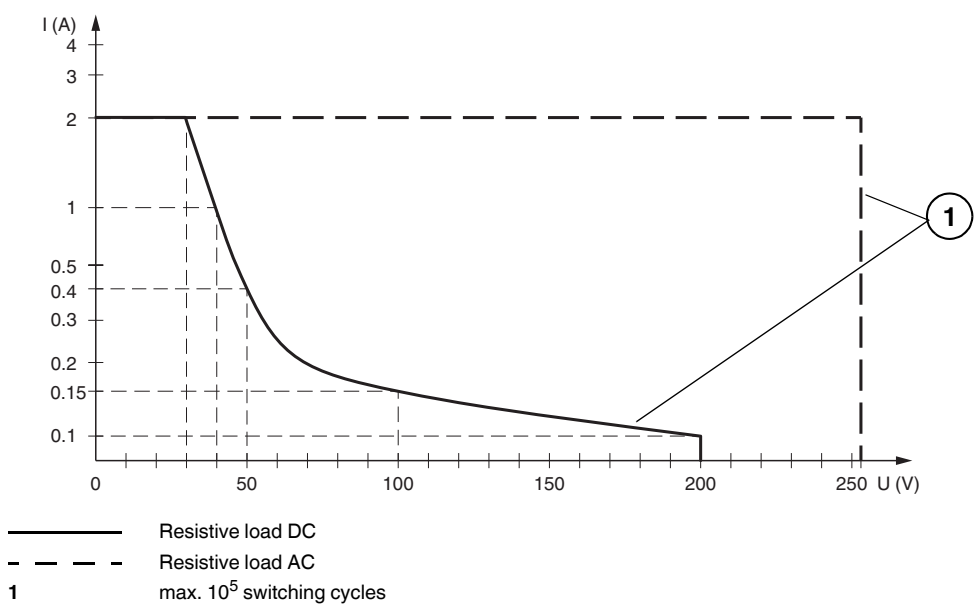

### Accessories

**PACT<sup>ware</sup>™**  
 Device-specific drivers (DTM)

**Adapter K-ADP1**  
 Programming adapter for parameterisation via the serial RS 232 interface of a PC/Notebook

For programming, please use the new version of adapter K-ADP1 (part no. 181953, connector length 14mm). When using the previous version K-ADP1 (connector length 18 mm) the plug is exposed by approx. 3 mm. The function is not affected.

**Adapter K-ADP-USB**  
 Programming adapter for parameterisation via the serial USB interface of a PC/Notebook

Release date 2016-04-18 11:12 Date of issue 2016-04-18 231195\_eng.xml