

LMT102

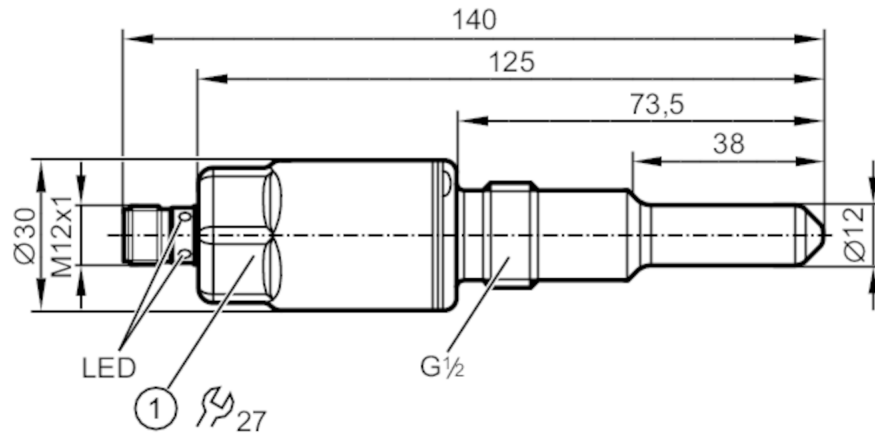

Sensor for point level detection

LMCCE-A12E-QSKG-2/US



1 Tightening torque 20...25 Nm



ACS



CRN cUL^{us}
LISTED



EAC

EC 1935/2004 EHEDG Certified



IO-Link

Product characteristics

Number of inputs and outputs	Number of digital outputs: 2
Factory setting	hydrous media
Process connection	threaded connection G 1/2 sealing cone

Application

Special feature	Gold-plated contacts
Media	Liquids; viscous media; powder
Recommended media	water; hydrous media; oils; oil-based media; powder
Cannot be used for	See the operating instructions, chapter "Function and features".
Probe length [mm]	38
Tank pressure [bar]	-1...40; (MAWP (for applications according to CRN): 40 bar / 4 MPa)

Oil	
Medium temperature [°C]	-20...100
Medium temperature short time [°C]	-20...150; (1 h)
Water	
Medium temperature [°C]	-20...100
Medium temperature short time [°C]	-20...150; (1 h)

Electrical data

Operating voltage [V]	18...30 DC
Current consumption [mA]	< 50
Protection class	III
Reverse polarity protection	yes

Inputs / outputs

Number of inputs and outputs	Number of digital outputs: 2
------------------------------	------------------------------

LMT102



Sensor for point level detection

LMCCE-A12E-QSKG-2/US

Outputs		
Total number of outputs	2	
Output signal	switching signal; IO-Link	
Electrical design	PNP/NPN	
Number of digital outputs	2	
Output function	normally open / normally closed; (parameterisable)	
Max. voltage drop switching output DC [V]	2.5	
Permanent current rating of switching output DC [mA]	100	
Short-circuit protection	yes	
Type of short-circuit protection	pulsed	
Overload protection	yes	
Measuring/setting range		
Factory setting	hydrous media	
Response times		
Response time [s]	< 0.5	
Interfaces		
Communication interface	IO-Link	
Transmission type	COM2 (38,4 kBaud)	
IO-Link revision	1.1	
SDCI standard	IEC 61131-9	
Profiles	Smart Sensor: Process Data Variable; Device Identification	
SIO mode	yes	
Required master port type	A	
Process data analogue	1	
Process data binary	2	
Min. process cycle time [ms]	2.3	
Supported DeviceIDs	Type of operation	DeviceID
	Default	370
Operating conditions		
Ambient temperature [°C]	-20...85	
Note on ambient temperature	Medium temperature: < 100 °C	
	-20...60 °C	
Storage temperature [°C]	Medium temperature: < 150 °C	
	-40...85	
Protection	IP 68; IP 69K	

LMT102



Sensor for point level detection

LMCCE-A12E-QSKG-2/US

Tests / approvals		
EMC	DIN EN 61000-6-2	
	DIN EN 61000-6-4	: open tanks
	DIN EN 61000-6-3	: closed tanks
Shock resistance	DIN EN 60068-2-27	50 g (11 ms)
Vibration resistance	DIN EN 60068-2-6	20 g (10...2000 Hz)
MTTF [years]	223	
UL approval	UL Approval no.	H001

Mechanical data		
Weight [g]	240	
Dimensions [mm]	Ø 30 / L = 125	
Materials	stainless steel (1.4404 / 316L); PEEK; PEI; FKM	
Materials (wetted parts)	PEEK; surface characteristics: Ra < 0,8 / Rz 4	
Process connection	threaded connection G 1/2 sealing cone	

Displays / operating elements		
Display	switching status	LED, yellow
	operating status	LED, green

Remarks		
Pack quantity	1 pcs.	

Electrical connection		
Connector: 1 x M12; Contacts: gold-plated		
		

LMT102



Sensor for point level detection

LMCCE-A12E-QSKG-2/US

Connection

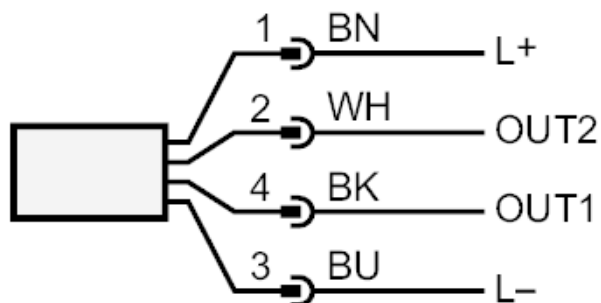

OUT1: switching output IO-Link Teach

OUT2: switching output

colours to DIN EN 60947-5-2

Core colours :

BK = black

BN = brown

BU = blue

WH = white