

Contrans P Transmitter

AMD 200 / AMD 220
for Gauge Pressure

Instructions

42/15-536-12 EN





EG-KONFORMITÄTSERKLÄRUNG

EC DECLARATION OF CONFORMITY
ATTESTATION DE CONFORMITE C.E.

Hersteller: ABB Automation Products GmbH
Manufacturer / Fabricant: Minden

Anschrift: Schillerstraße 72
Address / Adresse: D-32425 Minden

Produktbezeichnung: Meßumformer Contrans P – Reihe AMD 2..
Product name: Transmitter Contrans P – Series AMD 2..
Désignation du produit: Transmetteur Contrans P – Série AMD 2..

Das Produkt stimmt mit den Vorschriften folgender Europäischer Richtlinien überein:

This product meets the requirements of the following European directives:

Les produits répondent aux exigences des Directives C.E. suivantes:

89/336/EWG 89/336/EEC 89/336/C.E.E.	EMV-Richtlinie * <i>Electromagnetic Compatibility Directive *</i> <i>Directives concernant la compatibilité électromagnétique *</i>
73/23/EWG 73/23/EEC 73/23/C.E.E.	Niederspannungsrichtlinie * <i>EC-Low-Voltage Directive *</i> <i>Directives concernant la basse tension *</i>
97/23/EG 97/23/EEC 89/336/C.E.E.	Druckgeräterichtlinie <i>Pressure Instruments Directive</i> <i>Directives concernant les appareils soumis à pression</i>

*** einschließlich Änderungen und deutscher Umsetzung durch das EMVG und Gerätesicherheitsgesetz**

** including alterations and German realization by the EMC law and the instruments safety law*

** y compris les modifications et la réalisation allemande par la loi concernant la compatibilité électromagnétique et la sécurité d'appareils*

Die Übereinstimmung mit den Vorschriften dieser Richtlinien wird nachgewiesen durch die vollständige Einhaltung folgender Normen:

Conformity with the requirements of these Directives is proven by complete adherence to the following standards:

La conformité avec les exigences de ces directives est prouvée par l'observation complète des normes suivantes:

EN 50 081-1 / EN 50 082-2 / EN 61 010-1

14.12.1999

Datum
Date
Date

Dieter Friedemann
Standortleitung
Division manager
Responsable de la division

Friedrich Kipp
Qualitätsmanagement
Quality management
Assurance de la qualité

ABB Automation Products GmbH

Postanschrift:
Schillerstraße 72
32425 Minden

Besuchsanschrift:
Schillerstraße 72
32425 Minden
Telefon +49 (0) 5 71 830-0
<http://www.abb.de/automation>

Sitz der Gesellschaft:
Göttingen
Registergericht:
Göttingen
Handelsregister:
HRB 423
USt-IdNr.: DE 115 300 097

Geschäftsführung:
Uwe Alwardt (Vorsitz)
Andreas Beaucamp
Burkhard Block

Bankverbindung:
Commerzbank AG Minden
Konto: 3 133 063
BLZ: 490 400 43
Swift COBA DE FF 490

Content

1	General Description	3
2	Mounting	4
3	Electrical Connection	6
4	Commissioning	7
5	Checking the Calibration	8
6	Maintenance	8
7	Construction of Equipment	9
8	Changing the Equipment Settings	10
9	Fault Finding	12
10	Maintenance	16
11	Technical Data	20
12	Compliance with Pressure Guide Line (97/23/EG)	22
13	Dimensional Diagrams	23

1 General Description

Application

The AMD 200/AMD 220 Transmitter measures gauge pressure/partial vacuum or level of gases, vapours and liquids. The measuring ranges are graduated from 60 mbar(6 kPa) to 600 bar(60,000 kPa).

The process wetted parts are made of materials with durability to corrosion. The housing has a laminated epoxy resin paint finish as standard.

Indicators, recorders, controllers and process computers can be connected to the output signal of 4...20mA.

The actual transmitter design, such as transmitter type, serial number, material of the process wetted parts (isolating diaphragm (AMD 200) or sensing diaphragm (AMD 220), filling liquid (AMD 200), operating voltage,output signal, adjusting range for lower and upper range values and the adjusted measuring span,are described on the type plate.

If the instrument is an Ex design,then this is described on a separate type plate.

Construction

The AMD 200/AMD 220 Transmitter consists of the D036 (2) or D056 (1) Measuring Mechanism and the amplifier with potentiometers for lower range value,span and damping (8).

With the AMD 220 Transmitter the pressure (pe) acts di-rectly on the sensing diaphragm (4), with the AMD 200 Transmitter the pressure is transferred via the isolating diaphragm (5) and the filling liquid (6) to the sensing diaphragm (7).

In this way the sensing diaphragm is deflected and the output voltage of the pickup system changed. This pressure-proportional change is converted into a load-independent dc current.

Depending upon the design,there is a G 1/2 A (DIN 16 288) spigot or a 1/2-14 NPT female thread for the process connection to the measuring mechanism. The transmitter functions in two-wire technique,the same leads being used for the operating voltage (12...45 Vdc) and the output signal (4...20mA).

The electrical terminal housing is behind the screw lid and is spacially separated from the electronics.

There are test jacks in the terminal housing for measuring the output signal, without interrupting the signal current. Likewise, the lower range value,span and electrical damping can be adjusted here with potentiometers, whereby the span potentiometer is protected against unintentional maladjustment.

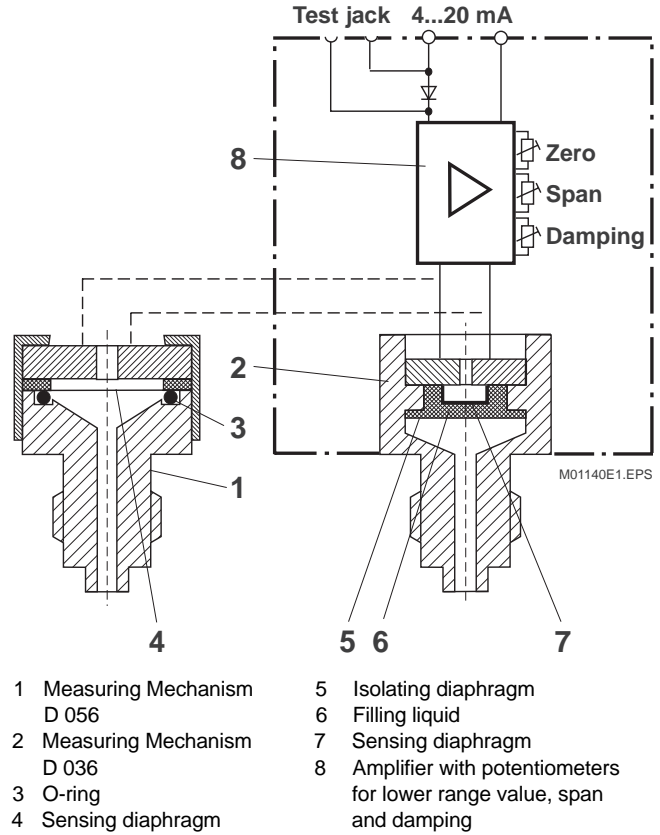

Fig.1. Functional Diagram

2 Mounting

General

Before mounting the transmitter, one must check whether the model of the equipment fulfils the measurement and safety requirements of the measuring position, e.g. with regard to materials, range, temperature, explosion protection and operating voltage. The relevant guidelines, orders, standards and the accident prevention regulations must also be observed.

General instructions are given below for correct mounting of the transmitter and measurement piping. The accuracy of the gauge pressure/partial vacuum or level measurement depends to a great extent on the correct fitting of the transmitter and the associated measurement piping. Critical ambient conditions, such as large change of temperature, vibration and shock should be kept away from the measuring assembly as far as possible. If severe ambient conditions cannot be avoided due to building, measurement technique or other reasons, then this may affect the quality of measurement! (See Section 10 "Technical Data").

If a remote seal with capillary tube is fitted to the transmitter then the publication Instructions 42/15-0813 EN is also to be taken into account.

Transmitter

The transmitter can be flanged directly onto the shut-off valve. Alternatively, there is a mounting bracket available as an accessory for wall or pipe mounting (2" pipe). The transmitter should be installed preferably in a vertical position.

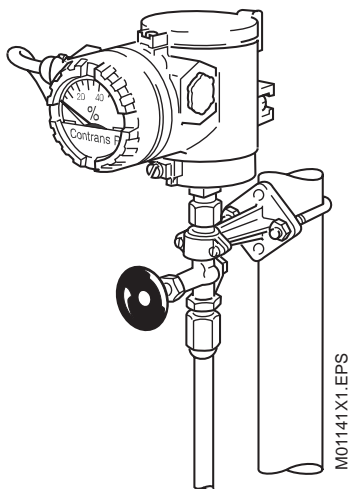

Fig. 2. Mounting directly on the shut-off fitting

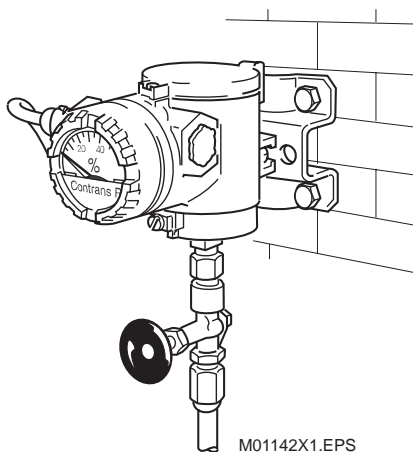
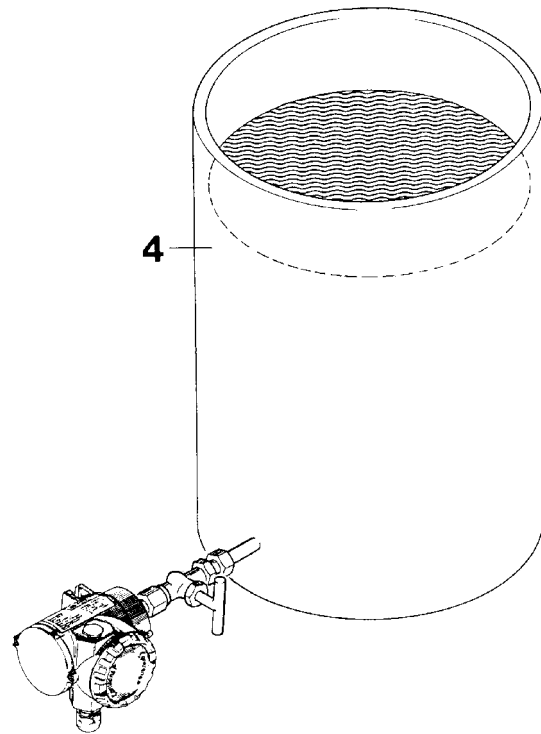

Fig. 3. Wall mounting with mounting bracket



- | | |
|------------------|------------------|
| 1 Transmitter | 3 Process pipe |
| 2 Shut-off valve | 4 Open container |

(18 354)

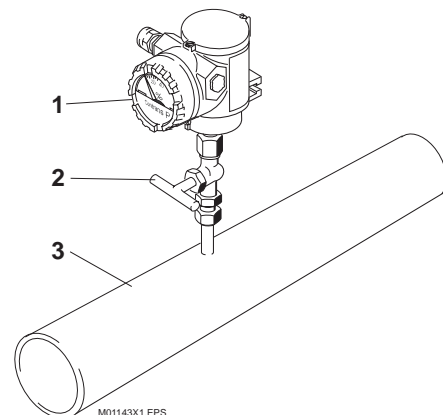

Fig. 4. Direct mounting

Measurement piping

The following points should be noted for correct installation:

- Keep the piping as short as possible and avoid sharp bends
- Install piping so that no deposits can collect, with falling/rising angle of not less than 8%
- Measurement piping should be blown through or flushed with compressed air or better still with the measuring medium before connecting to the measuring mechanism.
- Bleed all air out of piping for liquid measuring media.
- Ensure the correct layout of the process piping (e.g. tight?).
- Install measurement piping so that gas bubbles in liquid measurement, or condensate for gas measurement return to the process pipe.

Measuring assembly

Liquid measurement: The transmitter must be installed below if possible but at least at the same height as the tapping point. When it is installed below the tapping point the difference in height (H) between tapping and the transmitter causes a shift in the lower range value.

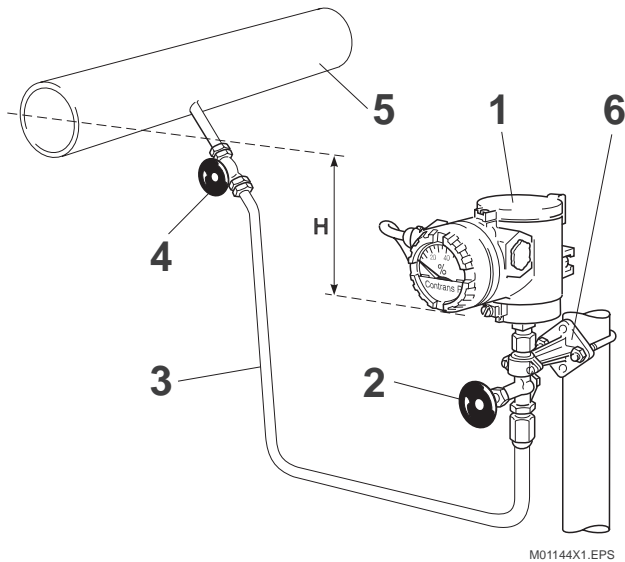

- | | |
|----------------------|--------------------------------|
| 1 Transmitter | 4 Tapping point shut-off valve |
| 2 Shut-off valve | 5 Process pipe |
| 3 Measurement piping | 6 Measuring instrument support |

Fig. 5. Example of measuring arrangement for liquid measurement

Gas measurement: The transmitter must be installed above the tapping point wherever possible.

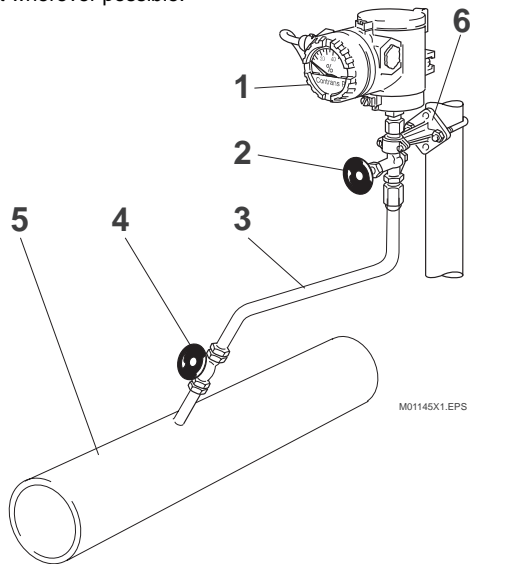

- | | |
|----------------------|--------------------------------|
| 1 Transmitter | 4 Tapping point shut-off valve |
| 2 Shut-off valve | 5 Process pipe |
| 3 Measurement piping | 6 Measuring instrument support |

Fig. 6. Example of measuring arrangement for gas

Vapour measurement: The transmitter should be installed as shown in Fig. 7, so that the measurement pipes remain filled with condensate and no vapour gets into the measuring mechanism directly.

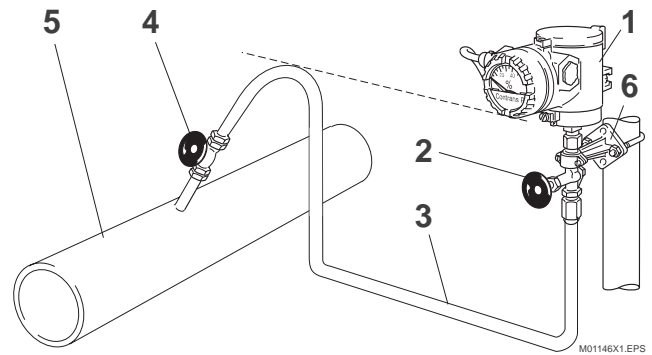

- | | |
|----------------------|--------------------------------|
| 1 Transmitter | 4 Tapping point shut-off valve |
| 2 Shut-off valve | 5 Process pipe |
| 3 Measurement piping | 6 Measuring instrument support |

Fig. 7. Example of measuring arrangement for vapour measurement

Level measurements: The transmitter must be installed beneath the tapping point or, at least, on the same height as it. The tapping point must be installed at the side of the container. The height of the transmitter is decisive for the lower range value.

For critical level measurements (e.g. viscous or corrosive measuring medium, or difficult installations), transmitters with remote seal systems (separate isolating diaphragm) are available.

Configurations other than those suggested above should be only used if local conditions do not permit such installations or if other aspects are against these configurations. In the case of fluid-filled measurement pipes, gas manifolds with vent valves must be provided if heights are excessive. In the case of gas-filled measurement pipes, condensate separators with drain valves must be provided at low points.

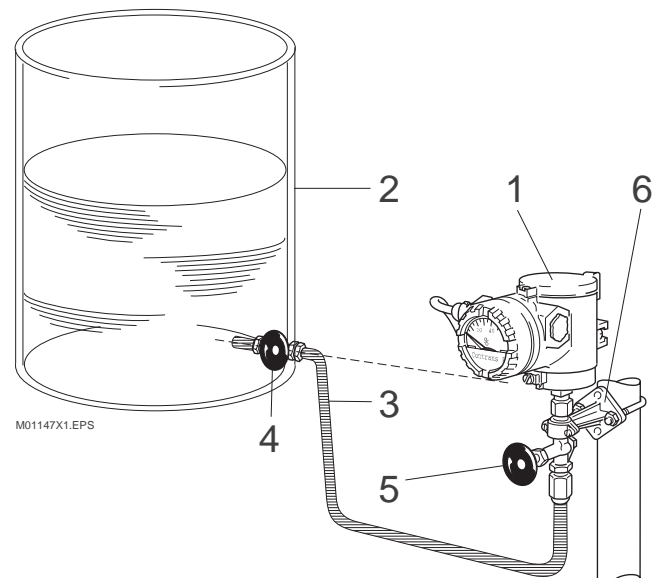

- | | |
|----------------------|--------------------------------|
| 1 Transmitter | 4 Tapping point shut-off valve |
| 2 Open container | 5 Shut-off valve |
| 3 Measurement piping | 6 Measuring instrument support |

Fig. 8. Example of level measurement in open container

3 Electrical Connections

- 2 x Pg 13.5 female thread with one Pg 13.5 gland
- 2 x Pg 13.5 female thread with two Pg 13.5 glands
- 2 x 1/2-14 NPT female thread

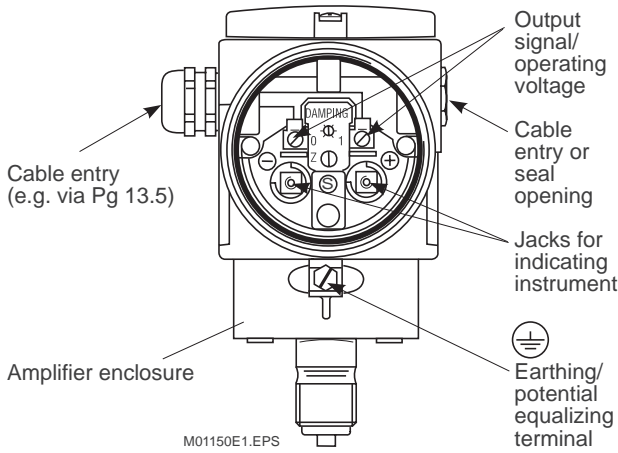

Fig. 9. Cable connection housing

If the transmitter is not already fitted with Pg 13.5 cable gland (perm. cable diameter 6 to 12 mm) thread, an appropriate cable gland must be screwed into tapped holes 1/2-14 NPT.

Unscrew the screw cover to obtain access to the electrical connections. The signal cable is taken through the cable gland into the cable connection housing and connected to the (+) and (-) terminals. The screw terminals are suitable for conductor crosssections of 0.5-2.5 mm². If a cable gland is not used, it must be closed by a suitable screwed stopper.

The glands (24 mm across flats for Pg 13.5) and blanking plugs (22 mm across flats for Pg 13.5) supplied with the instrument are loosely screwed into the amplifier housing. To obtain IP 65 Degree of Protection, these parts are to be screwed handtight into the housing.

- One Han 8U plug connector

The electrical connection is made by a plug and socket on the outside of the housing. The socket connector for the cable connection is enclosed with the transmitter for the plug version.

Consult the enclosed connection diagram.

Attention:

Check the connecting points again before pressing the sockets all the way into the contact insert. Incorrectly installed sockets can only be removed again with a special removal tool (item no.: 0949 813).

Contact insert (view onto sockets):

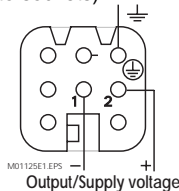

Crimp terminal for 0.75...1,0mm² conductor (also solderable)
Fig. 10. Connection diagram for socket connector

Installation:

The contact sockets (2) are crimped or soldered onto the cable ends from which 1.5...2 cm of the sheath and about 8 mm of the insulation has been removed and inserted from the near into the contact insert (1). The screwed gland (5), thrust ring (7), sealing ring (4) and grommet housing (3) must be pushed onto the cable in the specified order prior to installation (the sealing ring (4) may have to be adapted to the cable diameter first).

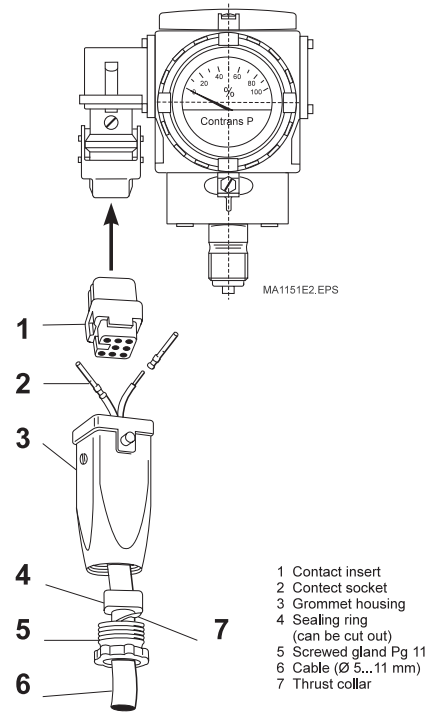

Fig. 11. Installing the socket connector

The signal wires do not have to be screened. However, they should not be laid with other power cables (with inductive load etc.). One should avoid the vicinity of large electrical plant. A connection terminal (⊥) is available for earthing (PE) externally on the housing.

Power supplies, batteries or mains equipment can be used for the operating voltage. Any ripple component in the supply voltage is negligible for the output signal. The permitted operating voltage (U_B) is 12 to 45V dc. The maximum load R of the signal current circuit is calculated from the following:

$$R \leq \frac{U_s - 12V}{20 \text{ mA}} \text{ k}\Omega \quad U_s = \text{is the supply voltage the power supply}$$

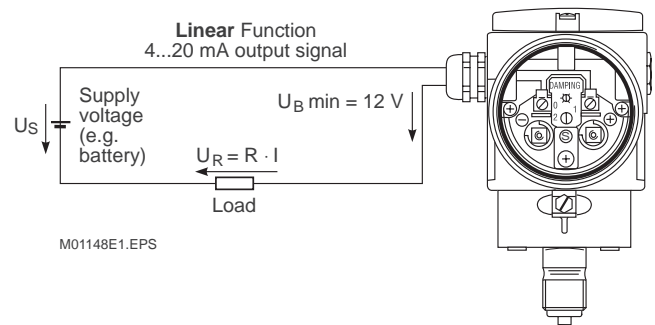

Fig. 12. Connection diagram

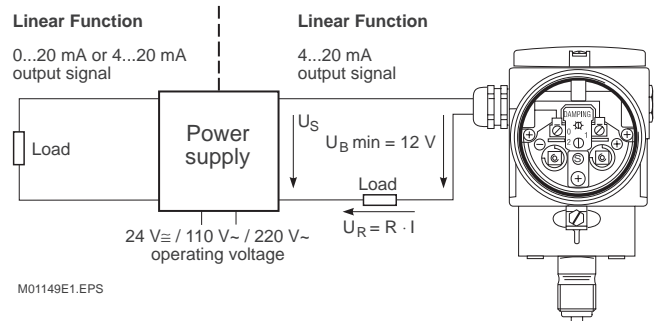

Fig. 13. Connecting to a power supply

Contact-Voltage Protection

The transmitter is not contact-voltage proof when the cap on the housing is open. Do not come in contact with any conductive parts.

Overvoltage Category

The transmitter's signal circuitry is in accordance with overvoltage category II (EN 61010).

Overcurrent Protection / Mains Switch

The transmitter itself does not have a on/off switch. Overcurrent protection and mains switch must be provided for systemside.

Grounding / Protective Conductor

The transmitter operates within the specified accuracy with common mode voltages between the signal wires and the housing up to 250V. In order to fulfill the requirements of the low voltage guidelines for the installation of electrical components (EU guidelines 73/23/EEC) the housing must be earthed/grounded if voltages of >150V could occur.

Notes on explosion protection

The national legal requirements, explosion protection guide-lines and the explosion test certificate of the equipment must be observed for installation (electrical connection, earthing/potential equalization etc.) of explosion protected transmitters. The certified explosion safety of the transmitter is given on the type label.

Transmitters of "intrinsically safe" type of protection according to CENELEC:

- Only fit intrinsically safe equipment in the transmitter signal current circuit.
- The signal current circuit may be interrupted while the transmitter is working (e.g. removing or replacing signal wires).
- the enclosure may be opened during operation.

4 Commissioning

When the transmitter has been installed, it is operated by switching on the supply voltage.

Note: If the transmitter is fitted with an indicating instrument, then the pointer of this instrument is under zero when the operating voltage is not applied.

The shut-off valves should be actuated in the following sequence (basic position of all valves is closed):

- Open shut-off valve if this is provided
- Open shut-off valve of manifold

The reverse sequence should be used when taking out of operation.

Damping

A transmitter output signal caused to be turbulent by the process can be electrically smoothed (damped or attenuated).

For this, there is a damping potentiometer with a scale, in the cable terminal housing (Fig. 9).

The time constants are continuously adjustable from 0.3sec to 6.6 sec.

When delivered, the damping potentiometer is adjusted to 0.3sec which corresponds to the left endstop. When turned clockwise, the time constant increases approximately 1sec per scale division.

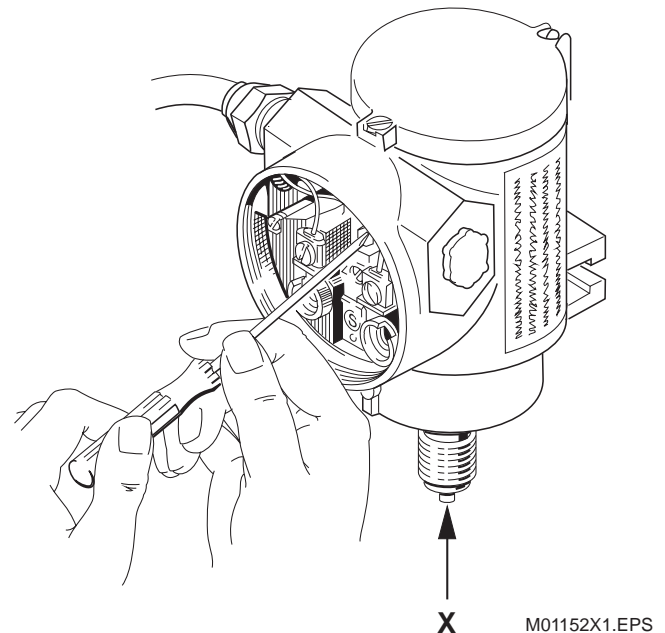

X = Pressure

Fig. 14 Adjusting the damping using a screwdriver

5 Checking the Calibration

The transmitter has been calibrated by the manufacturer in accordance with the ordering information. The values for the lower and upper range values can be seen on the type plate.

The following is basically valid; in the line "Einst./Adj", the first value printed (e.g. 0 bar) is always allocated to the 4mA signal and the second value printed (e.g. 25 bar) always to the 20mA signal.

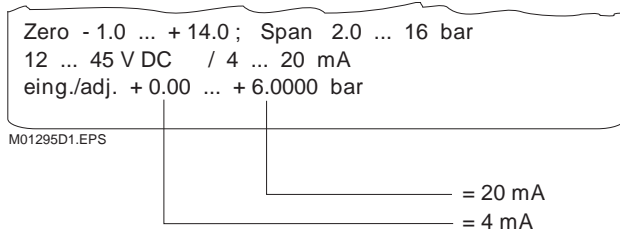

Fig. 15. Type plate (section)

The lower and upper range values are applied as pressure to the measuring mechanism for checking the transmitter.

Reducing stations with adjustable pressure and equalization indication can be used as generators. When connecting up, one must ensure that liquid residues (for gas measurements) or air bubbles (for liquid measurements) are avoided in the connecting pipes, as they can cause errors in checking.

The accuracy of the measuring instruments used should be many times better than that of the transmitter.

The output signal can be measured at the \oplus and \ominus test sockets. The sockets are suitable for 4.3mm plugs. Voltage drop of the ammeter < 300mA with 20mA. The ammeter can, of course, be connected in the output circuit.

If, with transmitters having the "Intrinsically Safe" type of protection in a potentially explosive atmosphere, an ammeter is connected to the test jacks then the sums of the capacitances and inductances of all current circuits, including transmitter (see type plate), have to be equal to or less than the permissible capacitance and inductance of the intrinsically safe signal current circuit (see supply unit type plate). Only passive test equipment or indicating instruments may be connected.

Note: The test sockets have M5 threads; they are for the fixed installation of an external indicating instrument.

Sequence of steps:

1. Check lower range value (4mA).
2. Check upper range value (20mA).

A correction of the lower range value does not affect the set-up span. Similarly, with correction of the span (upper range value), the set-up lower range value is not changed.

1. Checking lower range value (4mA)

The ammeter must show 4mA with the corresponding pressure applied according to the type plate.

Deviations can be corrected with the "Z" (zero) potentiometer using a screwdriver. Turning clockwise raises the output signal.

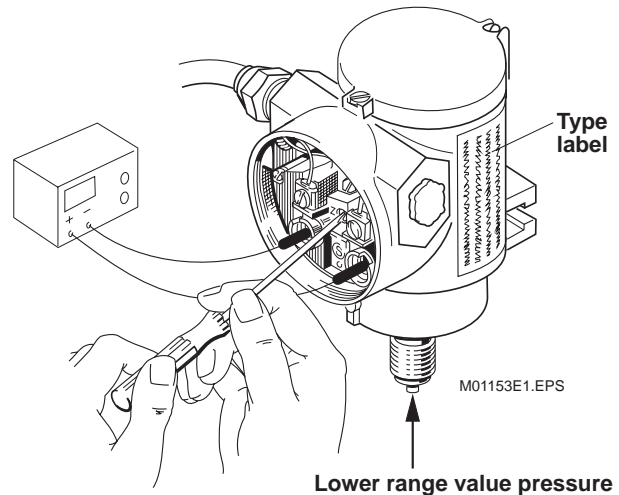

Fig. 16. Correcting the lower range value

2. Checking upper range value (20mA)

The ammeter must show 20mA with the corresponding pressure applied, according to the calibration plate.

Deviations can be corrected by the "S" (span) potentiometer, using a screwdriver.

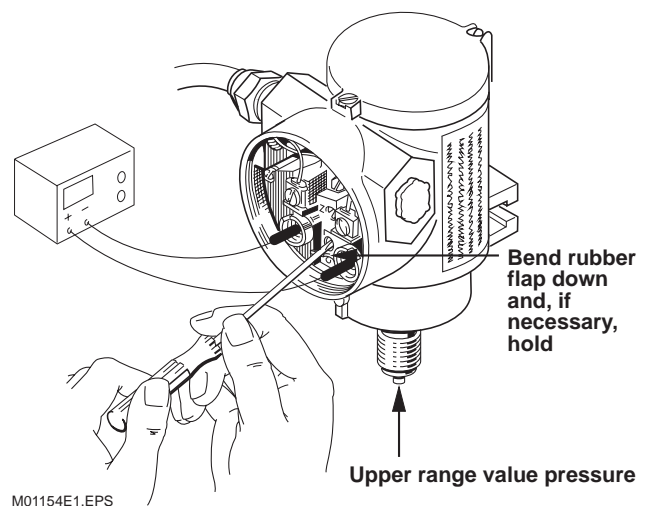

Fig. 17. Correcting the upper range value

6 Maintenance

The transmitter requires no maintenance.

It is sufficient if the output signal is checked at regular intervals - depending upon operating conditions - according to Section 5.

7 Construction of Equipment

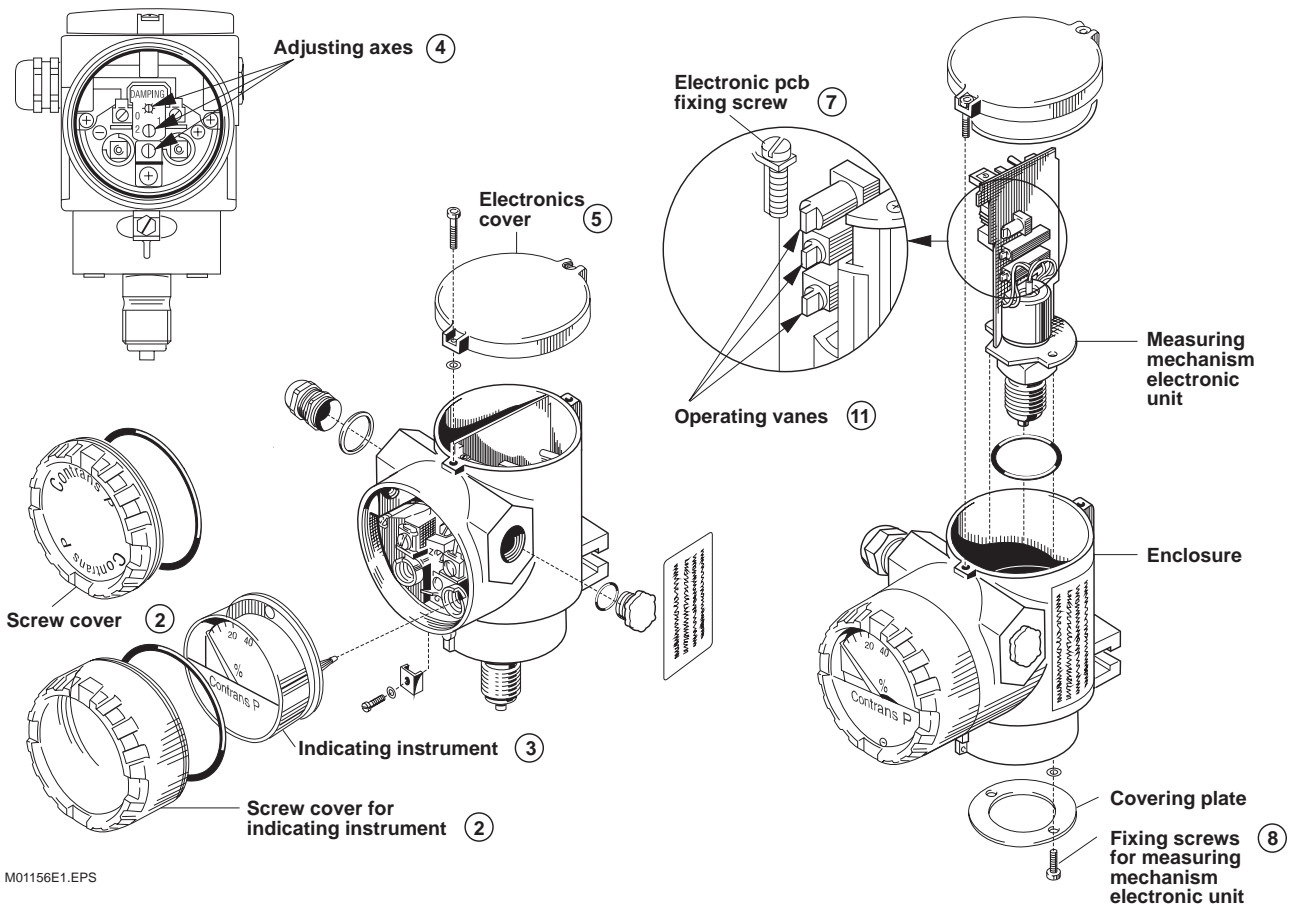

M01156E1.EPS

Fig. 18. Exploded view e.g. AMD 200

Instructions for removing and fitting the measuring mechanism / electronic unit

The amplifier contains CMOS circuits which can be damaged by electrostatic charges. Therefore personnel, working surface, instruments and tools must be at the same potential when working on the amplifier; e.g. by using an earthed, conductive stand and potential equalization to the body by a bonding strip.

Soldering instructions

Soldering may only be carried out on a transmitter in a switched-off state and with a soldering iron at floating potential. If in doubt, provide for potential equalization between the soldering iron tip and transmitter +ve output.

Removing (see Fig. 18 and 19)

1. With the AMD 200 having a **600 bar** range and a **1/2-14 NPT female thread** process connection, the **welded point** is to be removed and the **connecting union** (36mm across flats) loosened by counter holding on the measuring mechanism square shaft (22 mm across flats) (Fig. 19). Unscrew the connecting union from the measuring mechanism.
2. Unscrew **screw cover**.
3. Pull out **indicating instrument** - if fitted.
4. Place the slots of the **adjusting axes** for the S, Z and DAMPING potentiometers, as shown in Fig. 18, into a vertical position.
5. Free the **electronics cover** (captive Phillips screws, size 1 screw-driver).
6. Unsolder the two wires - coming from the cable terminal housing - from the + (slot) and - (solder lug) solder points on the electronic pcb (note positions). Observe soldering instructions.
7. Screw out the **electronic pcb fixing screw**.

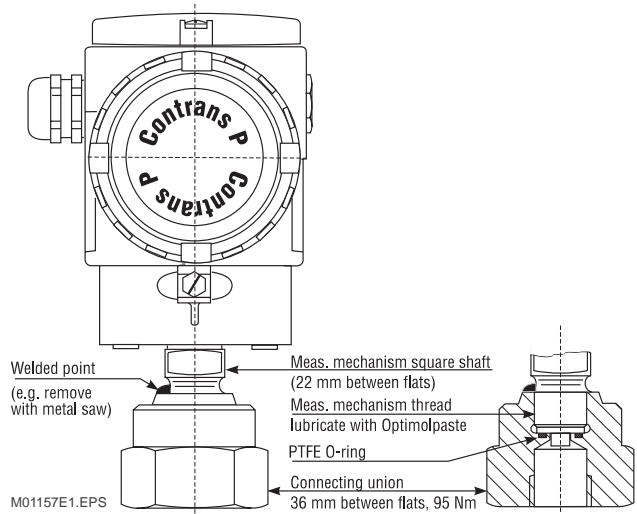

Fig. 19. AMD 200 having a 600 bar range and 1/2 - 14 NPT female thread process connection

8. Screw out the two **fixing screws of the measuring mechanism/electronic unit** (4 mm socket-head screws).
9. Take the **measuring mechanism/electronic unit** carefully out of the **enclosure**.

Fitting (see Fig. 18 and 19)

Fitting is carried out in the reverse sequence. However there are some additional instructions to observe.

10. Check O-rings for damage and if necessary renew (Spare Parts Data Sheet 15-9.85 EN).

11. Set the **operating vanes** of the potentiometers parallel to the electronic pcb (place the adjusting axes into a vertical position!).
12. Lubricate the **two fixing screws for the measuring mechanism/electronic unit** with optimolpaste LN AU 598 (supplied by Optimol Ölwerke GmbH, D - Munich). Tighten screws with a torque $M_A = 4 \text{ Nm}$.
13. With the **AMD 200** having a **600bar** range and a **1/2-14 NPT female thread** process connection, renew the O-ring between the measuring mechanism and the connecting union (Spare Parts Data Sheet 15-9.85 EN). Insert the new O-ring into the inlaid groove of the connecting union. Lubricate the **measuring mechanism threading** (1/2 A) with Optimolpaste LN AU 598 and tighten the **connecting union** with a tightening torque $M_A = 95 \text{ Nm}$ by counter holding on the measuring mechanism square shaft (Fig. 19).

8 Changing the Equipment Setting

Required if,

- the transmitter is to be set to a different measuring span or a different lower range value from that given on the calibration label (Fig. 15).
- the amplifier or the measuring mechanism was replaced.

General

The span and the lower range value can be adjusted anywhere between the values given on the type label. These values, which are determined by the measuring mechanism, must not be exceeded. The span is calibrated by setting the upper range value.

A correction of the lower range value does not affect the set-up span. Similarly, with a correction of the span (upper range value), the set up lower range value is not changed.

The accuracy of the measuring instruments used must be many **times better** than that of the transmitter.

Hereinafter, the adjustment procedure differs depending on the serial number of the transmitter. The serial number is shown in the second line of the type label.

Setting-up Procedure for Transmitters up to F.-No. 155xx x x49999

1. For presetting the lower range value there is a slide switch on the electronic pcb (Fig. 20). Using Table 1, determine the position of the slide switch according to the desired characteristic.

Note: An alternation of the characteristic (rising/falling and vice versa) can only be carried out by the manufacturer.
2. If it is necessary to change the position then, with the power supply switched off, unscrew the electronics cover (Fig. 18).
3. Slide the switch into the position determined from Table 1.
4. Unscrew the screw cover and, if fitted, pull out the indicating instrument (Fig. 18).
5. Connect an ammeter (milliampere scale, $R_i \leq 15 \text{ ohm}$) to the \oplus and \ominus test jacks (4 mm diam./M5 thread) (Fig. 9).
6. Switch on the power supply.
7. Apply the pressure corresponding to the lower range value of the desired span to the measuring mechanism. Using a screwdriver, adjust the "Z" potentiometer (Fig. 16) until the ammeter indicates 4 mA (turning clockwise raises the output signal).

Note: Altering the lower range value does **not** affect the span.
8. Apply the pressure corresponding to the upper range value of the desired span to the measuring mechanism. Using a screwdriver, adjust the "S" potentiometer (Fig. 17) until the ammeter indicates 20 mA.

Note: Altering the span does **not** affect the lower range value.
9. Check the lower range value again.
10. Record the adjusted values.



Bild 19. Position of the slide switch e.g. AMD 200

Adjusting limits of the lower range value in % of max. span	Required characteristic		Presetting the lower range value with slide switch
	rising	falling	
0%, +35% -35%, 0%			
+30%, +87.5% +30%, +100%			
-100% (-1bar), -30% -87.5%, -30%			

Table 1. Presetting the lower range value

Setting-up Procedure for Transmitters from F.-No. 155xx x x5xxxx

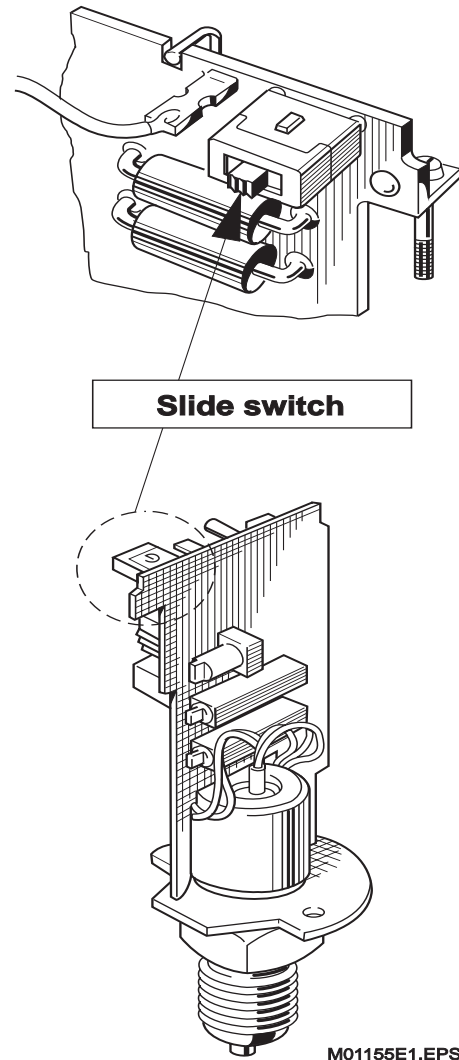
1. For presetting the lower range value there is a **plug-jumper** and a **solder link** on the electronic pcb (Fig. 21). Using Table 2, determine the position of the **plug-jumper** and a **solder link** according to the desired characteristic.
2. If it is necessary to change the position then, with the power supply switched off, unscrew the electronics cover (Fig. 18).
3. Position plug-in jumper and, if necessary, solder link as determined according to table 2.
4. Unscrew the screw cover and, if fitted, pull out the indicating instrument (Fig. 18).
5. Connect an ammeter (milliampere scale, $R_i \leq 15 \text{ ohm}$) to the \oplus and \ominus test jacks (4 mm diameter / M5 thread) (Fig. 9).
6. Switch on the power supply.
7. Apply the pressure corresponding to the lower range value of the desired span to the measuring mechanism. Using a screwdriver, adjust the "Z" potentiometer (Fig. 16) until the ammeter indicates 4 mA (turning clockwise rises the output signal).
Note: Altering the lower range value does **not** affect the span.
8. Apply the pressure corresponding to the upper range value of the desired span to the measuring mechanism. Using a screwdriver, adjust the "S" potentiometer (Fig. 17) until the ammeter indicates 20 mA.
Note: Altering the span does **not** affect the lower range value.
9. Check the lower range value again.
10. Record the adjusted values.

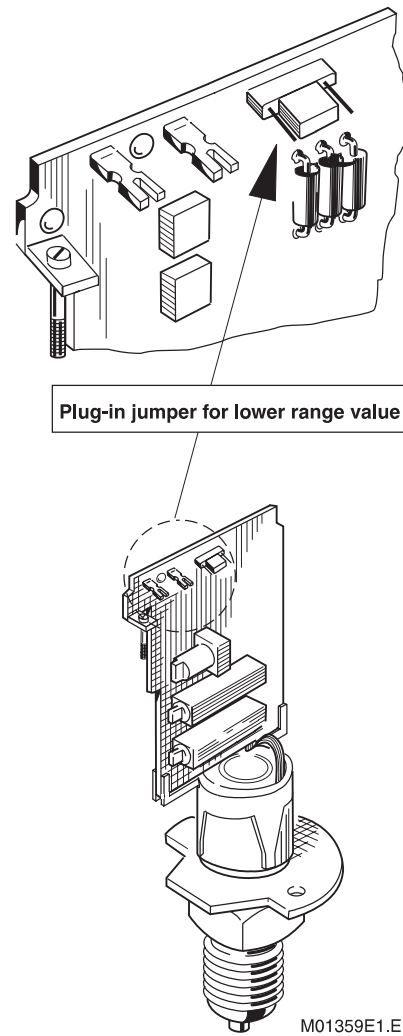

Fig. 21. Position of the "plug-in jumper" e.g. AMD 200

Adjusting limits of the lower range value in % of max. span	Rising characteristic	Falling characteristic	Presetting the lower range value with plug-in jumper
	Position: "solder link for characteristic" Af <input type="checkbox"/> <input checked="" type="checkbox"/> As	Position: "solder link for characteristic" Af <input checked="" type="checkbox"/> <input type="checkbox"/> As	
	Desired lower range value	Desired lower range value	
0%, +35% -35%, 0%			
+30%, +87.5% +30%, +100%			
-100% (-1bar), +30% -80%, +30%			

Table 2. Presetting the lower range value and characteristic

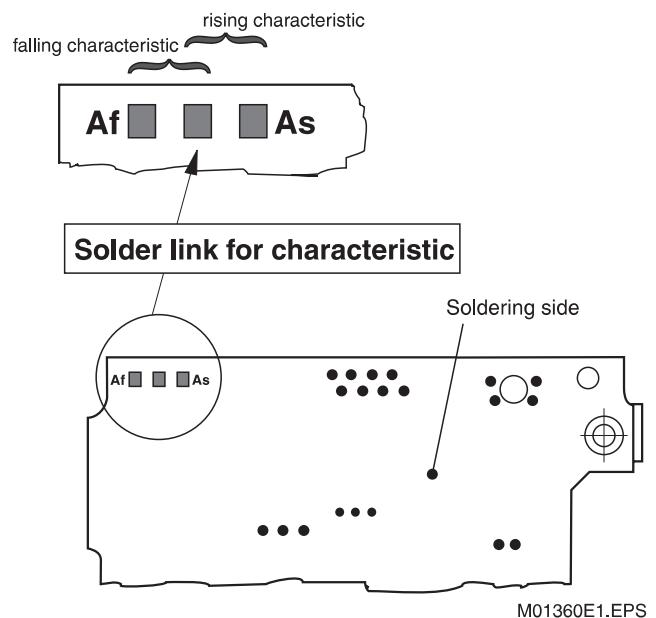

Fig. 22. Position of the "Solder link for characteristic"

9 Fault Finding

Faults and possible causes

1. No output signal

- Shut-off valve still closed.
- Pressure pipe or valve blocked.
- Incorrect supply voltage or wrong polarity.

2. Irregular output signal

- Pulsating measuring medium.
- Load outside permitted limits.
- Pressure pipe or valve blocked.
- Interruption or short circuit in the measuring circuit.

If these faults can be excluded, the following tests should be carried out to determine whether the fault is in the measuring mechanism or the electronics. Observe Section 7 "Instructions for removing and fitting the measuring mechanism/electronic unit"

**Flow diagram for fault finding on the AMD 200
up to F.-No. 155xx x x49999**
(see Fig. 23)

Observe "Handling instructions" (Page 9)

1. Remove measuring mechanism/electronic unit (Observe Section 7 "Construction of Equipment" subsection "Instructions for removing and fitting the measuring mechanism/electronic unit")
2. Unsolder the wiring between the measuring mechanism and electronic on the electronic pcb (solder terminals A(r), B(bk), C(bu), E(wt), D(ye) see Fig. 23).
3. Use a **high impedance** instrument for measuring voltage ($R_i \geq 100 \text{ k}\Omega$).
4. Join the "wt" and "ye" wires together.
5. Apply a voltage of **1.60 Vdc** to the joined "wt-ye" wires and the black wire.
6. Using a high impedance meter, measure between the "r" and "bu" wires:
 - with $p_e = 0\%$ range
measure $< \pm 10 \text{ mVdc}$,
 - with $p_e = 100\%$ range 1)
measure e.g. 40 ... 100 mVdc.
7. If these values are obtained, then it can be assumed that the amplifier is defective.
8. Exchange the amplifier or measuring mechanism according to Section 10 "Repairs".

- 1) If the full pressure (100 % p_e) can not be applied to the measuring mechanism, then take the turn-down factor into account!

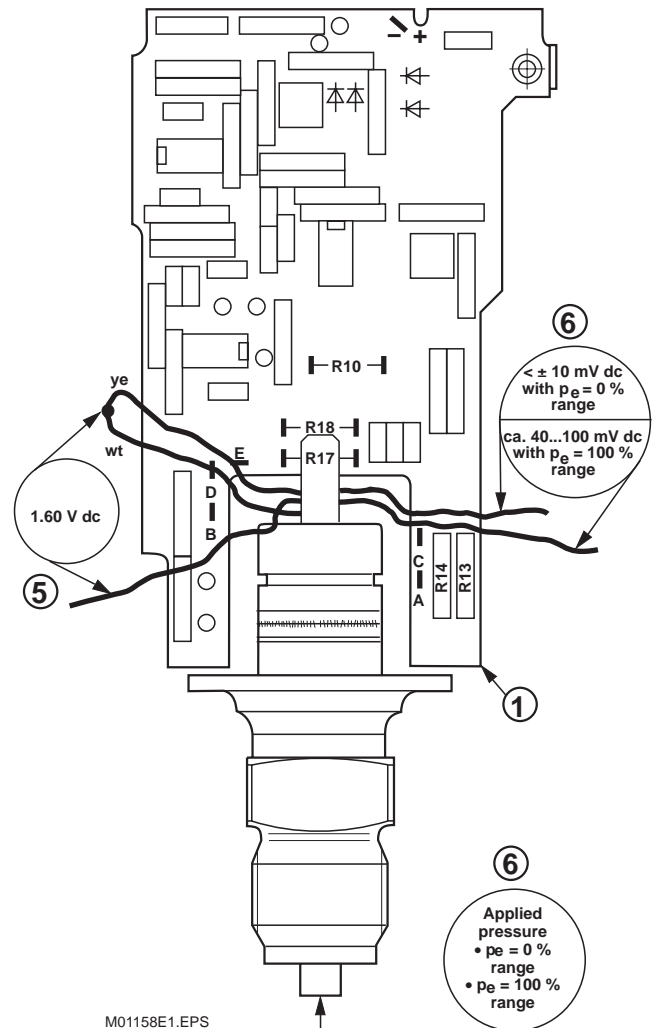

Fig. 23. Measuring mechanism/electronic unit of the AMD 200

**Flow diagram for fault finding on the AMD 200
from F.-No. 155xx x x5xxxx**
(see Fig. 24)

Observe "Handling instructions" (Page 9)

1. Remove measuring mechanism/electronic unit (Observe Section 7 "Construction of Equipment" subsection "Instructions for removing and fitting the measuring mechanism/electronic unit")
 2. Unsolder the wiring between the measuring mechanism and electronic on the electronic pcb (ribbon cable-Fig. 24-View X).
 3. Use a **high impedance** instrument for measuring voltage ($R_i \geq 100 \text{ k}\Omega$).
 4. Connect the two outer wires with each other (Fig. 24 - view X).
 5. Apply a voltage of **1.60 Vdc** to the "connected wires" and the "middle" wire (Fig. 24).
 6. By means of a **high impedance** instrument the following has to be measured between the two **short** wires:
 - with $p_e = 0\%$ range
measure $< \pm 10 \text{ mVdc}$,
 - with $p_e = 100\%$ range 1)
measure e.g. 40 ... 100 mVdc.
 7. If these values are obtained, then it can be assumed that the amplifier is defective.
 8. Exchange the amplifier or measuring mechanism according to Section 10 "Repairs".
-
- 1) If the full pressure (100 % p_e) can not be applied to the measuring mechanism, then take the turn-down factor into account!

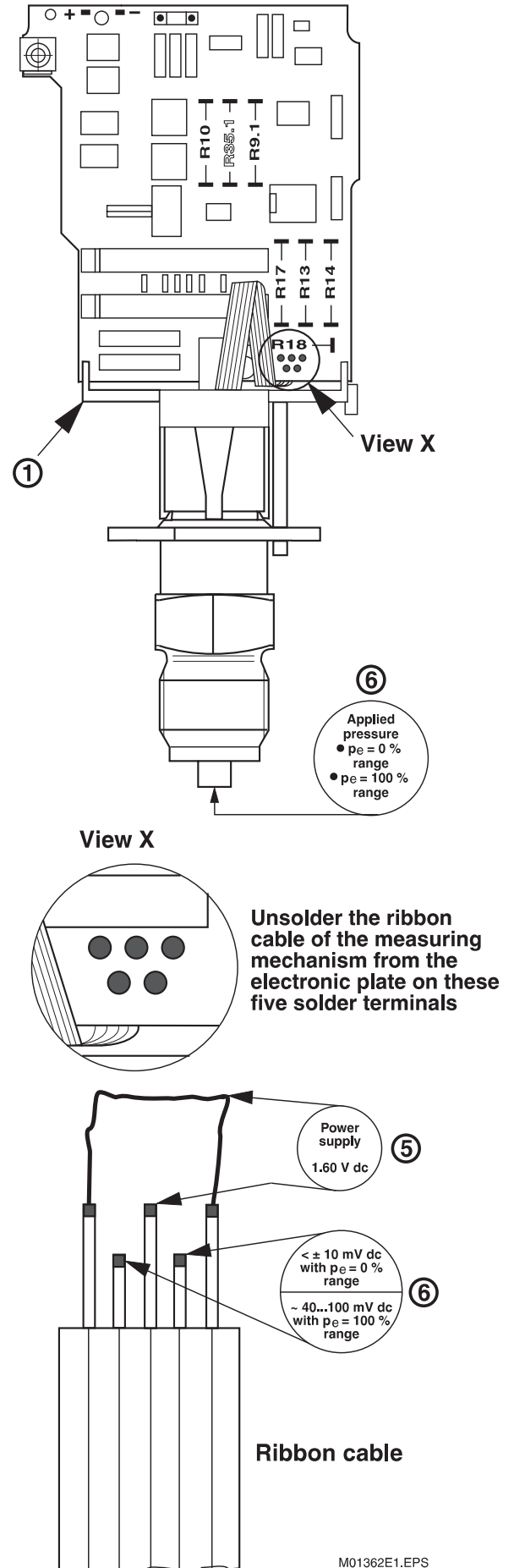

Fig. 24. Measuring mechanism / electronic unit of the AMD 200

**Flow diagram for fault finding on the AMD 220
up to F.-No. 155xx x x49999**

(see Fig. 25 and 26)

Observe "Handling instructions" (Page 9)

1. Remove measuring mechanism/electronic unit (observe Section 7 "Construction of Equipment" subsection "Instructions for removing and fitting the measuring mechanism/electronic unit").
2. Unsolder the **wiring** between the measuring mechanism and the electronic unit - solder terminals **Cref**, **Cp** and **CB** (under certain circumstances,twice). Observe soldering instructions! (Fig. 25).
3. Using a **capacitance bridge** (Fig. 26),
 - with $p_e = 0\%$ of full measuring range,measure the capacitance $C_{p,0}$ between the "Cp" and "CB" wires and also the capacitance $C_{ref,0}$ between the "Cref" and "CB" wires. In both cases the capacitance should be **90...140 pF**.
 - with $p_e = 100\%$ of full measuring range,measure the capacitance $C_{p,100}$ between the "Cp" and "CB" wires and insert the values measured above into the formula below:

$$\frac{|C_{p,100} - C_{p,0}|}{|C_{p,100}|} = 0,1...0,3 \text{ } ^1)$$

The ratio so calculated must be **0.1...0.3**

4. Checking zero offset:
The difference in amount between the values $C_{p,0}$ and $C_{ref,0}$ measured under point 3, must be smaller than or equal to the product of **0.1 x $C_{p,0}$** .

$$|C_{p,0} - C_{ref,0}| \leq 0,1 \times C_{p,0}$$

5. If one of the values measured or calculated under points 3 and 4 is outside the stated tolerances, then it can be assumed that the measuring mechanism is defective.
6. Replace amplifier or measuring mechanism according to Section 10 "Repairs".

- 1) If the full pressure (100 % p_e) can not be applied to the measuring mechanism, then both of the specified limit ratios (0.1 and 0.3) are to be divided by the **turn-down factor**.

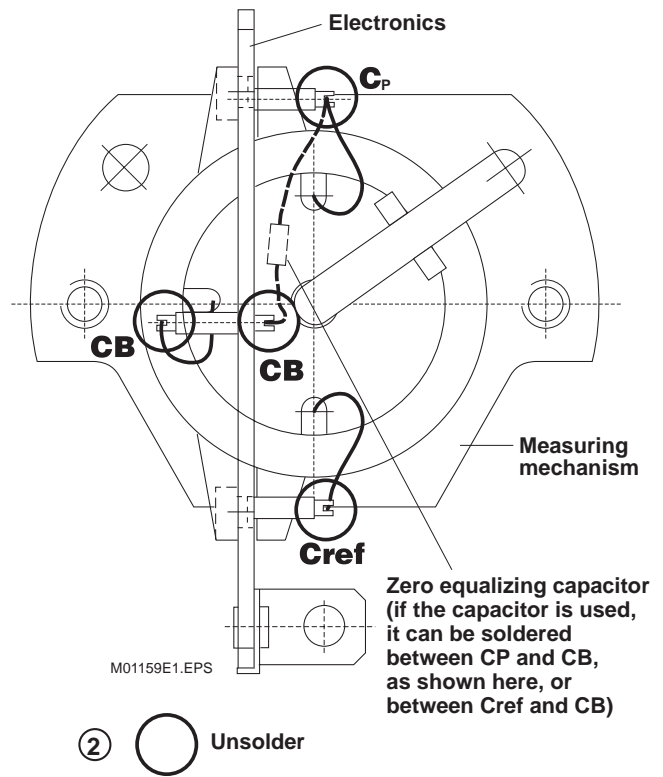

Fig. 25.

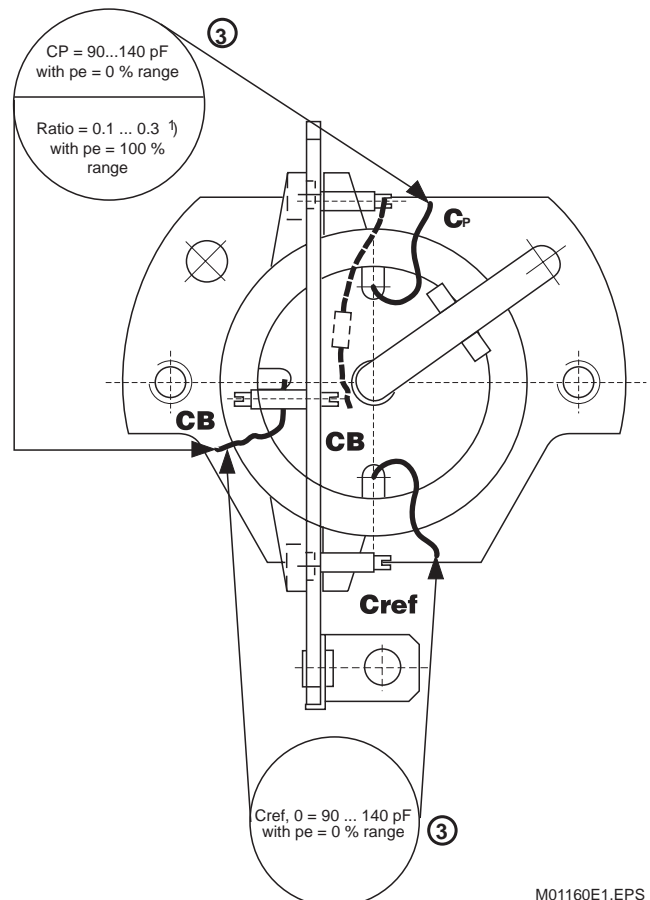

Fig. 26.

**Flow diagram for fault finding on the AMD 220
from F.-No. 155xx x x5xxxx**
(see Fig. 27 and 28)

Observe "Handling instructions" (Page 9)

1. Remove measuring mechanism/electronic unit (observe Section 7 "Construction of Equipment" subsection "Instructions for removing and fitting the measuring mechanism/electronic unit").
2. Unsolder the **wiring** between the measuring mechanism and the electronic unit - solder terminals **Cref**, **Cp** and **CB**. Observe soldering instructions! (Fig. 27).
3. Using a **capacitance bridge** (Fig. 28),
 - with $p_e = 0\%$ of full measuring range, measure the capacitance $C_{p,0}$ between the "Cp" and "CB" wires and also the capacitance $C_{ref,0}$ between the "Cref" and "CB" wires. In both cases the capacitance should be **90...140 pF**.
 - with $p_e = 100\%$ of full measuring range, measure the capacitance **Cp,100** between the "Cp" and "CB" wires and insert the values measured above into the formula below:

$$\frac{|C_{p,100} - C_{p,0}|}{|C_{p,100}|} = 0,1...0,3^{1)}$$

The ratio so calculated must be **0.1...0.3**

4. Checking zero offset:
The difference in amount between the values $C_{p,0}$ and $C_{ref,0}$ measured under point 3, must be smaller than or equal to the product of **0.1 x $C_{p,0}$** .

$$|C_{p,0} - C_{ref,0}| \leq 0,1 \times C_{p,0}$$

5. If one of the values measured or calculated under points 3 and 4 is outside the stated tolerances, then it can be assumed that the measuring mechanism is defective.
6. Replace amplifier or measuring mechanism according to Section 10 "Repairs".

- 1) If the full pressure (100 % p_e) can not be applied to the measuring mechanism, then both of the specified limit ratios (0.1 and 0.3) are to be divided by the **turn-down factor**.

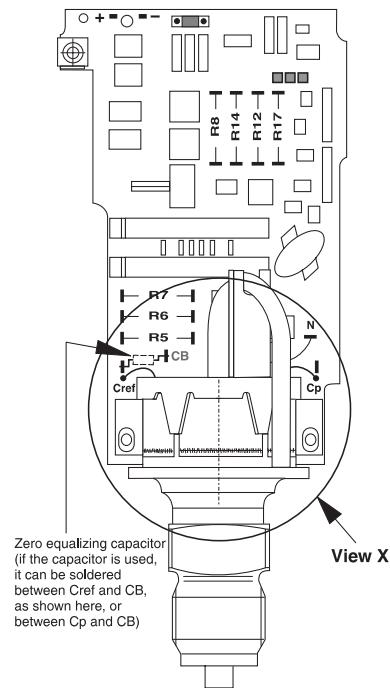

View X
(Outline without purging hose and mount)

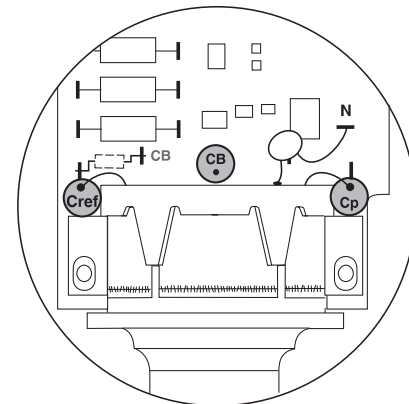

● **unsolder** M01364E1.EPS

Fig. 27.

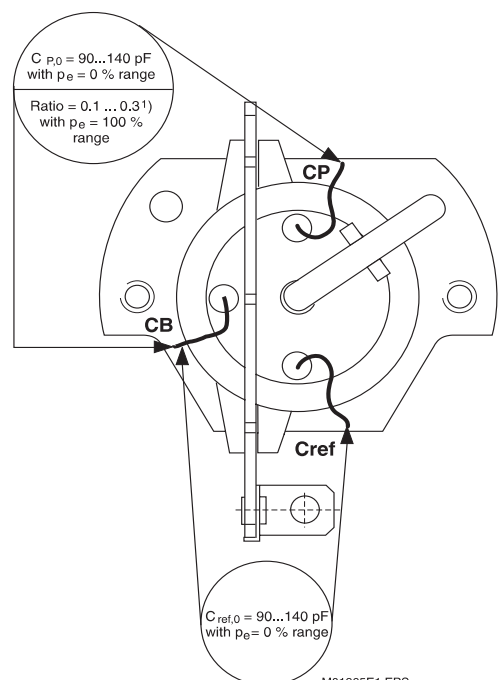

Fig. 28. M01365E1.EPS

10 Repairs

The appropriate safety precautions must be observed before, during and after the repair.

Only dismantle the transmitter to the extent necessary for the cleaning, inspection, repair and replacement of faulty parts

Note Sections 6 on "Maintenance" and 7 on "Construction of Equipment" subsection "Instructions for removing and fitting the measuring mechanism/electronic unit".

Warning: Explosion proof transmitters may only be repaired by the manufacturer or must be certified by an approved expert after the repair!

Exchangeability(in general only within the same transmitter type)
AMD 220: Independent of the serial no., the measuring mechanisms / electronics can be exchanged without restriction.
AMD 200: Observe serial no. (F.-No.)!
 Measuring mechanisms / electronics **up to** serial no. 155xx x x49999 **cannot** be combined with those **from** serial no. 155xx x x5xxxx and vice versa.

Calibrate the transmitter after the repair.
 Measuring mechanisms and measuring mechanisms with remote seals fitted, can only be repaired by the manufacturer

Handling instructions

The amplifier contains CMOS circuits which can be damaged by electrostatic charges. Therefore personnel, working surface, instruments and tools must be at the same potential when working on the amplifier; e.g. by using an earthed, conductive stand and potential equalization to the body by a bonding strip.

Soldering may only be carried out on a transmitter in a switched-off state and with a soldering iron **at floating potential**. If in doubt provide for potential equalization between the soldering iron tip and transmitter +ve output.

AMD 200 Transmitter up to F.-No. 155xx x x49999

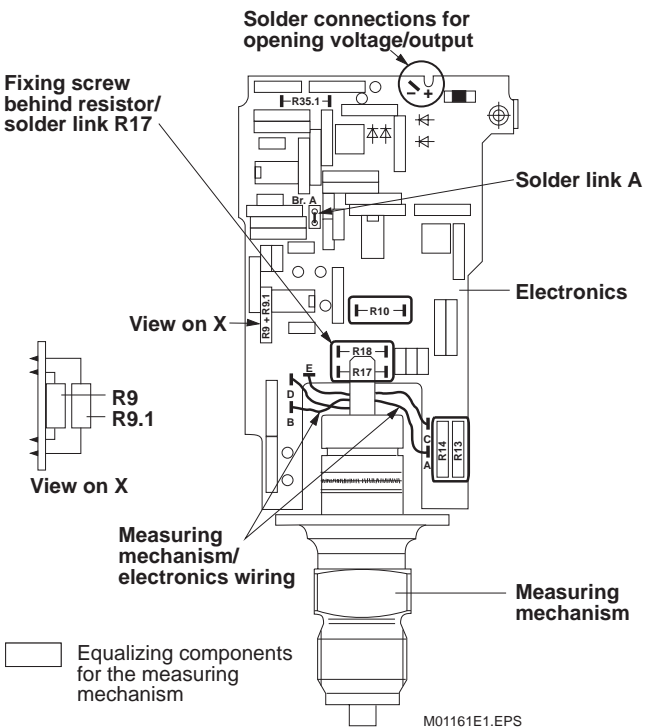

Fig. 29. Component side of the Measuring Mechanism / Electronic Unit

Wire colour (measuring mechanism)	⇒ Solder terminal (electronic)
Black	B
Yellow	D
White	E
Blue	C
Red	A

Fig.30. Connection plan for wiring the measuring mechanism/electronic unit.

● Replacing the electronics

1. Observe the removing instructions in Section 7 "Construction of Equipment".
2. Unsolder the **wiring** between the measuring mechanism and the electronics on the electronic pcb (solder terminals A,B,C,D and E, see Fig. 29). Observe soldering instructions!
3. Unsolder one side of resistor/wire link R17 and loosen the fixing screw there underneath (Phillips screw, size 0 screwdriver). Lay the defective electronic to one side.
4. Screw the new electronic pcb (Spare Parts Data Sheet 15-9.85 EN) to the measuring mechanism.
5. Wire the electronics to the measuring mechanism according to the connection plan, Fig. 30. Observe soldering instructions!
6. Resolder the **equalizing components for the measuring mechanism** (Fig. 29) from the defective electronic pcb onto the new one. Observe the soldering instructions.
7. If **resistor R9.1** is not soldered in on the defective electronic pcb (see Fig.29), then R9.1 is to be cut out of the new electronic pcb.
8. Check if **link A** is soldered in.
9. Assemble the transmitter in reverse sequence. Observe the fitting instructions in Section 7 "Construction of Equipment"! If the transmitter has still to be calibrated, then do not fit the screw cover and electronics cover yet.
10. Calibrate the transmitter according to Section 8 "Changing the Equipment Setting".

● Replacing the measuring mechanism

(Note: The equalizing components which are specifically for the measuring mechanism are on the card **0632 367**. This card is supplied together with the measuring mechanism and is not to be separated from this measuring mechanism).

1. Observe the removing instructions in Section 7 "Construction of Equipment"!
2. Unsolder the **wiring** between the measuring mechanism and the electronics on the electronic pcb (solder terminals A,B,C,D and E, see Fig. 29). Observe soldering instructions!
3. Unsolder R10, R17, R18 and either R13 or R14 (Fig. 29, equalizing components for the measuring mechanism) and loosen the **fixing screw** (Phillips screw, size 0 screwdriver) underneath R17. Lay the defective measuring mechanism on one side.
4. Screw the new measuring mechanism (Spare Parts Data Sheet 15-9.85 EN) to the electronic pcb.
5. Wire the measuring mechanism to the electronics according to the connection plan (Fig. 30). Observe the soldering instructions!

6. Solder the **equalizing components supplied with the measuring mechanism** into the corresponding places on the electronic pcb (Fig. 29, equalizing components for the measuring mechanism). Observe the soldering instructions!

Note:

 - If a resistor is supplied for R13, then R14 remains unconnected and vice versa.
 - If a resistor is supplied for R17, then a solder link is soldered in for R18 and vice versa.
7. Assemble the transmitter in reverse sequence. Observe the fitting instructions in Section 7 "Construction of Equipment"! If the transmitter has still to be calibrated, then do not fit the screw cover and electronics cover yet.
8. Calibrate the transmitter according to Section 8 "Changing the Equipment Setting".

and at the same time pull the plate to the top out of the mount. Put defective electronics aside.

4. Push the new electronic pcb (Spare Parts Data Sheet 15-9.85 EN) into the mount until the snap connection locks in.
5. Push the ribbon cable between electronic unit and mount up to the soldering side. Solder the wires of the ribbon cable to the respective point on the electronic unit (Fig. 24). Observe soldering instructions!
6. Resolder the **equalizing components for the measuring mechanism** (Fig. 31) from the defective electronic pcb onto the new one. Observe the soldering instructions.
7. If **resistor R 9.1** is not soldered in on the defective electronic pcb (see Fig. 31), then R9.1 is to be cut out of the new electronic pcb.
8. Check if **solder link for characteristic: Af or As** (Fig. 22) is soldered in.
9. Assemble the transmitter in reverse sequence. Observe the fitting instructions in Section 7 "Construction of Equipment"! If the transmitter has still to be calibrated, then do not fit the screw cover and electronics cover yet.
10. Calibrate the transmitter according to Section 8 "Changing the Equipment Setting".

**AMD 200 Transmitter
from F.-No. 155xx x x5xxxx**

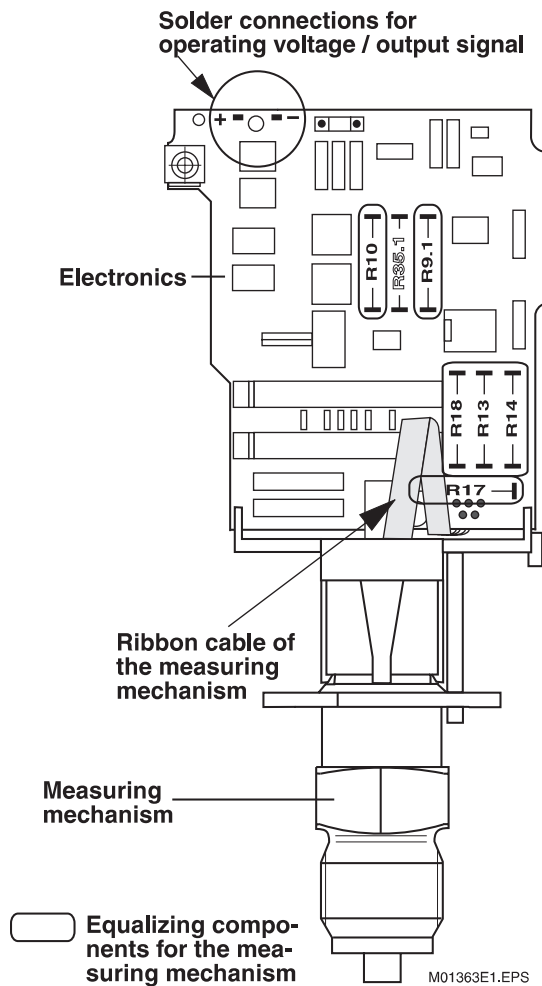

Fig. 31. Component side of the Measuring Mechanism / electronic unit of the AMD 200

● **Replacing the measuring mechanism**

(Note: The equalizing components which are specifically for the measuring mechanism are on card **0632 367**. This card is supplied together with the measuring mechanism and is not to be separated from this measuring mechanism).

1. Observe the removing instructions in Section 7 "Construction of Equipment"!
2. Unsolder the **ribbon cable** between the measuring mechanism and the electronics on the electronic pcb (5 solder terminals, see Fig. 24). Observe soldering instructions!
3. Unsolder R10, R17, R18 and either R13 or R14 (Fig. 31, equalizing components for the measuring mechanism).
4. Hold the measuring mechanism in one hand and take the electronic plate with the other hand from outside in the middle between index finger and thumb. Press the plate slightly towards the ribbon cable and at the same time pull the plate to the top out of the mount.
5. Assemble new measuring mechanism (Spare Parts Data Sheet 15-9.85 EN) with the electronic plate.
6. Push the ribbon cable between electronic unit and mount up to the soldering side. Solder the wires of the ribbon cable to the respective point on the electronic unit (Fig. 24). Observe soldering instructions!
7. Solder the **equalizing components** supplied with the measuring mechanism into the corresponding places on the electronic pcb (Fig. 31, equalizing components for the measuring mechanism). Observe the soldering instructions!

Note:

- If a resistor is supplied for R13, then R14 remains unconnected and vice versa.
- If a resistor is supplied for R17, then a solder link is soldered in for R18 and vice versa.

● **Replacing the electronics**

1. Observe the removing instructions in Section 7 "Construction of Equipment"!
2. Unsolder the **ribbon cable** between the measuring mechanism and the electronics on the electronic pcb (5 solder terminals, see Fig. 24). Observe soldering instructions!
3. Hold the measuring mechanism in one hand and take the electronic plate with the other hand from outside in the middle between index finger and thumb. Press the plate slightly towards the ribbon cable

8. Assemble the transmitter in reverse sequence. Observe the fitting instructions in Section 7 "Construction of Equipment"! If the transmitter has still to be calibrated, then do not fit the screw cover and electronics cover yet.

9. Calibrate the transmitter according to Section 8 "Changing the Equipment Setting".

AMD 220 Transmitter up to F.-No. 155xx x x49999

● Replacing the electronics

1. Observe the removal instructions in Section 7 "Construction of Equipment".
2. Unsolder the **wiring** between the measuring mechanism and the electronics on the electronic pcb (solder terminals **Cref**, **Cp**, **CB** (under certain circumstances,twice) and **N**). Observe soldering instructions! Note pin allocation!
3. Using a small screwdriver, unlock the **snap connection** between the measuring mechanism and the electronic pcb and pull the electronics away from the measuring mechanism (Fig. 32). Lay the defective electronics on one side.
4. Push the new electronics (Spare Parts Data Sheet 15-9.85 EN) onto the measuring mechanism until the connection locks in.
5. Wire the electronics to the measuring mechanism, as before. Observe the soldering instructions!
6. Unsolder **resistors R6 and R17** (Fig. 32) from the **new** electronic pcb and remove!
7. Resolder the **equalizing components for the measuring mechanism** (Fig. 32) including the **zero equalizing capacitor** from the defective electronic pcb onto the new electronic pcb. Observe the soldering instructions!
8. Connect **link B or C** (Fig. 32), corresponding to the defective electronic pcb, with a solder link.
9. Check if **link A** is connected with a solder link.
10. Assemble the transmitter in reverse sequence.Observe the fitting instructions in Section 7 "Construction of Equipment"! If the transmitter has still to be calibrated, then do not fit the screw cover and electronics cover yet.
11. Calibrate the transmitter according to Section 8 "Changing the Equipment Setting".

● Replacing the measuring mechanism

(Note: The equalizing components which are specifically for the measuring mechanism are on the card **0632 367**. This card is supplied together with the measuring mechanism and is not to be separated from this measuring mechanism).

1. Observe the removal instructions in Section 7 "Construction of Equipment"!
2. Unsolder the **wiring** between the measuring mechanism and the electronics on the electronic pcb (solder terminals **Cref**, **Cp**, **CB** (under certain circumstances,twice) and **N**). Observe soldering instructions! Note pin allocation!
3. Unsolder R5, R6, R7, R8, R12, R14 and R17 (Fig. 32, Equalizing components for the measuring mechanism).
4. Unsolder **capacitor C22** from measuring mechanism chassis (Fig. 33).
5. Using a small screwdriver, unlock the **snap connection** between the measuring mechanism and the electronics and pull the electronics away from the measuring mechanism (Fig. 32). Lay the defective measuring mechanism on one side!

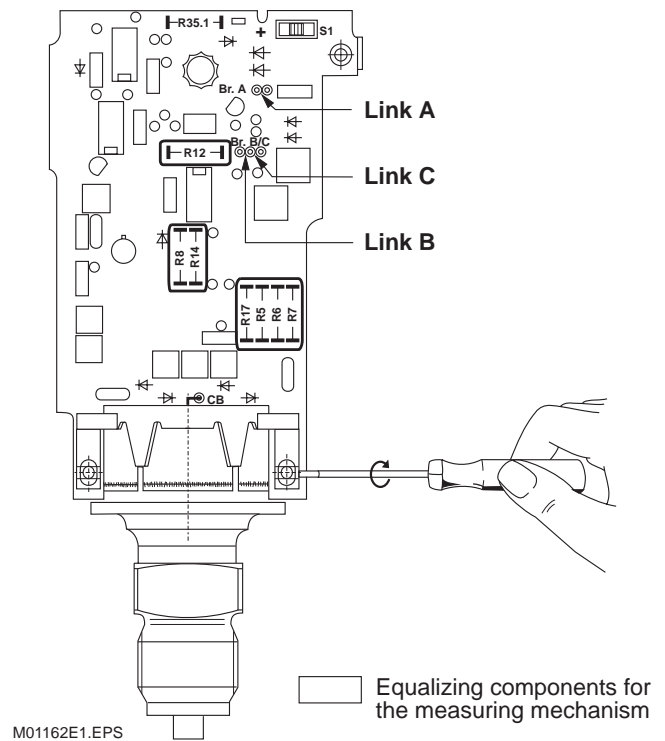

M01162E1.EPS

Fig. 32. Component side of the measuring mechanism/electronic unit of the AMD 220

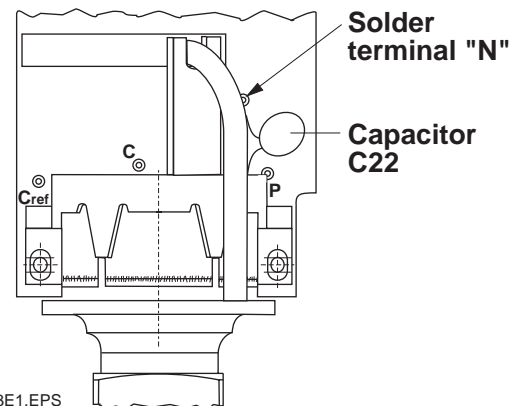

M01163E1.EPS

Fig. 33.

6. Join the new measuring mechanism (Spare Parts Data Sheet 15-9.85 EN) together with the electronic pcb until the snap connection locks in.
7. Solder **capacitor C22** (Fig. 33) - unsoldered under point 4 - into its corresponding position. Observe soldering instructions!
8. Solder the **equalizing components supplied with the measuring mechanism** to the corresponding positions on the electronic pcb (Fig. 32, equalizing components for the measuring mechanism and Fig. 25 for the zero equalizing capacitor).
9. Connect **link B or C**, corresponding to the card 0632 367 supplied, with a solder link.
10. Assemble the transmitter in reverse sequence.Observe fitting instructions in Section 7 "Construction of Equipment"! If the transmitter still has to be calibrated, then do not fit the screw cover and the electronics cover.
11. Calibrate the transmitter according to Section 8 "Changing the Equipment Setting".

AMD 220 Transmitter from F.-No. 155xx x x5xxxx

● Replacing the electronics

1. Observe the removal instructions in Section 7 "Construction of Equipment".
2. Unsolder the **wiring** (Fig. 27 and 35) between the measuring mechanism and the electronics on the electronic pcb (solder terminals **Cref**, **Cp**, **CB** and **N**). Observe soldering instructions! Note pin allocation!
3. Using a small screwdriver, unlock the **snap connection** between the measuring mechanism and the electronic pcb and pull the electronics away from the measuring mechanism (Fig. 34). Lay the defective electronics on one side.
4. Push the new electronics (Spare Parts Data Sheet 15-9.85 EN) onto the measuring mechanism until the connection locks in.
5. Wire the electronics to the measuring mechanism, as before.
6. Unsolder **resistors R6 and R17** (Fig. 34) from the **new** electronic pcb and remove!
7. Resolder the **equalizing components for the measuring mechanism** (Fig. 34) including the **zero equalizing capacitor** from the defective electronic pcb onto the new electronic pcb. Observe the soldering instructions!
8. Connect **link B or C** (Fig. 34), corresponding to the defective electronic pcb, with a solder link.
9. Check if **solderlink for characteristic: Af or As** (Fig. 22) is soldered in.
10. Assemble the transmitter in reverse sequence. Observe the fitting instructions in Section 7 "Changing the Equipment Setting"! If the transmitter has still to be calibrated, then do not fit the screw cover and electronics cover yet.
11. Calibrate the transmitter according to Section 8 "Changing the Equipment Setting".

● Replacing the measuring mechanism

(Note: The equalizing components which are specifically for the measuring mechanism are on the card **0632 367**. This card is supplied together with the measuring mechanism and is not to be separated from this measuring mechanism).

1. Observe the removal instructions in Section 7 "Changing the Equipment Setting"!
2. Unsolder the **wiring** between the measuring mechanism and the electronics on the electronic pcb (solder terminals **Cref**, **Cp**, **CB** (under certain circumstances, twice) and **N**). Observe soldering instructions! Note pin allocation!
3. Unsolder R5, R6, R7, R8, R12, R14 and R17 (Fig. 34, Equalizing components for the measuring mechanism).
4. Unsolder **capacitor C22 (1)** from the measuring mechanism chassis (Fig. 35).
5. Using a small screwdriver, unlock the **snap connection** (soldered side) between the measuring mechanism and the electronics and pull the electronics away from the measuring mechanism (Fig. 34). Lay the defective measuring mechanism on one side!
6. Join the new measuring mechanism (Spare Parts Data Sheet 15-9.85 EN) together with the electronic pcb until the snap connection locks in.
7. Solder **capacitor C22** (Fig. 35) - unsoldered under point 4 - into its corresponding position. Observe soldering instructions!

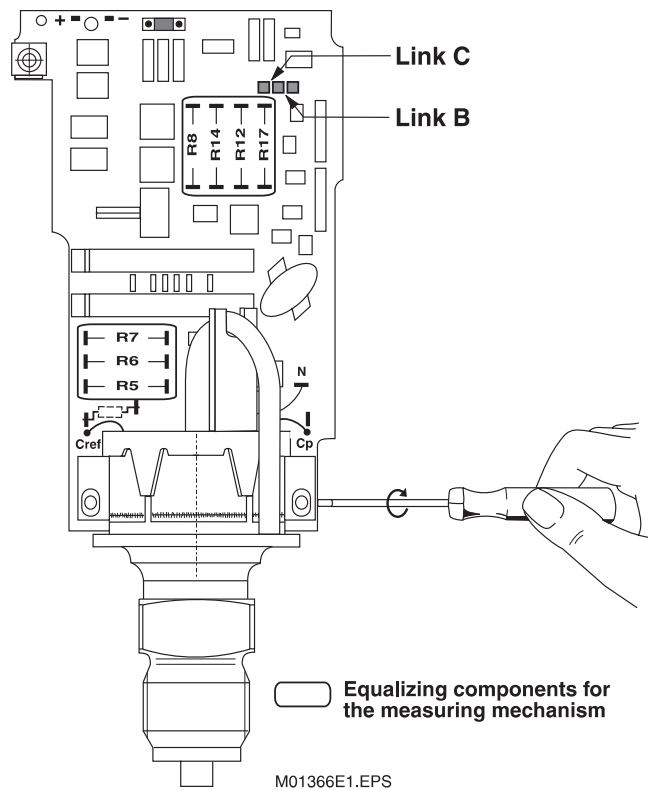
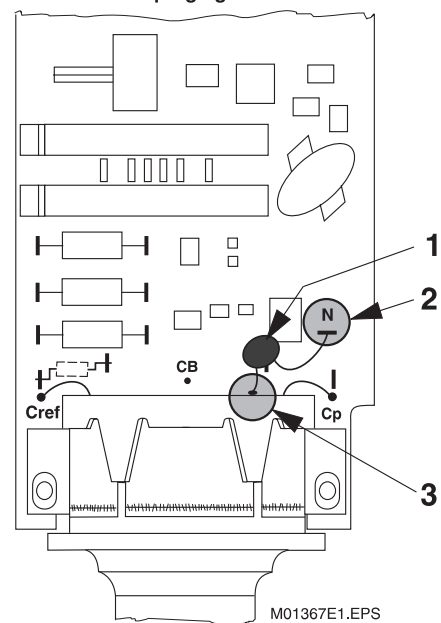

Fig. 34. Component side of the measuring mechanism/electronic unit of the AMD 220

Outline without purging hose and mount



1 Capacitor C22 2/3 unsolder

Fig. 35.

8. Solder the **equalizing components supplied with the measuring mechanism** into the corresponding positions on the electronic pcb (Fig. 34, equalizing components for the measuring mechanism and Fig. 25 for the zero equalizing capacitor).
9. Connect **link B or C**, corresponding to the card 0632 367 supplied, with a solder link.
10. Assemble the transmitter in reverse sequence. Observe fitting instructions in Section 7 "Changing the Equipment Setting"! If the transmitter still has to be calibrated, then do not fit the screw cover and the electronics cover.
11. Calibrate the transmitter according to Section 8 "Changing the Equipment Setting".

Return

Defective transmitters/units are to be sent to the repair department, if possible stating the fault and its cause.

Note: When ordering spare parts/-instruments please quote the serial-no. (F.-No.) of the original transmitter.

11 Technical Data

Measuring media

Gases, vapours, liquids.

Limits of measurement

-100 % (> -1 bar) and +100 % of the actual maximum span.

Lower range value

Continuously adjustable between -100 % (> -1 bar) and +87.5% of the maximum span.

Measuring spans

Continuously adjustable between 12.5 %...100 % of the maximum span. With range 60 mbar: min. measuring span is 5 mbar.

● AMD 220

5 ... 60 mbar (0.5 ... 6 kPa)
50 ... 400 mbar (5 ... 40 kPa)
0.3125 ... 2.5 bar (31.25 ... 250 kPa)
2 ... 16 bar (0.2 ... 1.6 MPa)

● AMD 200

0.1325...2.5 bar (31.25...250 kPa)
2...16 bar (0.2...1.6 MPa)
5...40 bar (0.5...4.0 MPa)
12.5...100 bar (1.25...10 MPa)
31.25...250 bar (3.125...25 MPa)
75...600 bar (7.5...60 MPa)

Characteristic

Linear, rising or falling.

Over-ranging limits

● AMD 220

Ranges \leq 400 mbar: 10 bar,
● with O-ring perfluorocautchouc: 5 bar
Ranges 2,5 bar: 25 bar
Ranges 16 bar: 32 bar

● AMD 200

Ranges 2.5 bar ... 250 bar: 2 x times the range end value
Range 600 bar: 900 bar

Filling liquid of the mechanism

● AMD 200

See type label
IK = silicone oil
LH = carbon fluoride

● AMD 220

"Dry measuring mechanism" without filling liquid

Filling volume (AMD 200)

approx. 0.2 cm³.

Process wetted parts (steel materials acc. to DIN 17 007)

● Process connection

See Type plate
1.4571 = austenitic stainless steel (316Ti) or
1.4404 = austenitic stainless steel (316L) or
Hast.C = Hastelloy C

● Diaphragm

See Type plate
1.4435 = austenitic stainless steel (316L) or
Hast.C = Hastelloy C
ceramic Al₂O₃.

● O-ring

AMD 200

PTFE, only with the 600 bar range, having a 1/2-14NPT female thread as process connection

AMD 220

See Type plate
Buna (standard) or
Viton (see Ambient Conditions), or perfluoroelastomer(=PTFE)
• permissible operating temperature
Ranges \leq 400 mbar: -15°C ... +80°C
Ranges > 400 mbar: 0°C ... +80°C



The O-ring prevents the medium reaching the atmosphere

Operating voltage at the transmitter

$U_{B, \min.}$ = DC 12 V, $U_{B, \max.}$ = DC 45 V.

Load R

$R \leq \frac{U_S - 12V}{I_{\max}}$ k Ω U_S = supply voltage

Output signal

4 ... 20 mA, gauge-pressure proportional.

Amplifier enclosure

Material: Copper free die-cast aluminium (GD-AISI). Screw cover made of polycarbonate.

Protective varnish: Epoxy resin.

Degree of Protection: IP 65 (jet waterproof) according to EN 60529 (= NEMA Standard Type 4).

Colour: Gravel grey, RAL 7032.

Process connection

DIN 16 288-Form B-G 1/2A (R 1/2" manometer) plug or 1/2-14 NPT female thread.

Electrical connection

0.5 to 2.5 mm² screw terminals or Han 8U plug connector

Type of mounting

Screwed directly onto a fitting. Wall or pipe mounting with a mounting bracket (optional). Installation position is vertical (preferably).

Weight

approx. 0.85 kg.

Ambient Conditions

Ambient temperature range
(note temperature classes
explosion proof
transmitters!)

-40 °C to +80 °C;
AMD 220: -15 °C to +80 °C or 0 °C to
+80 °C with O-ring
perfluoroelastomer;
-18 °C to +80 °C with O-ring Viton
AMD 200: -20 °C to +80 °C with filling
liquid LH (carbon fluoride).

Process temperature range

-40 °C to +80 °C;
AMD 220: -15 °C to +80 °C or 0 °C to
+80 °C with O-ring
perfluoroelastomer;
-18 °C to +80 °C with O-ring Viton
AMD 200: -20 °C to +80 °C with filling
liquid LH (carbon fluoride).

Storage and transportation
temperature range

-50 °C to +80 °C

Humidity

≤ 95% annual mean, condensation
permitted**Explosion Protection****Type of protection
according to CENELEC:****Intrinsically safe "i"
DIN EN 50 020.**

Type
Identification code (DIN EN 50 014)
Type Approval Certificate
Test certificate can be obtained under No.49/15-31 EX.

AMD 200
EEx ib IIC T4 or T6
PTB Nr. Ex-89.C.2098
Test certificate can be obtained under No.49/15-31 EX.

Type
Identification code (DIN EN 50 014)
Type Approval Certificate
Test certificate can be obtained under No.49/15-32 EX.

AMD 220
EEx ib IIC T4 or T6
PTB Nr. Ex-89.C.2179
Test certificate can be obtained under No.49/15-32 EX.

Transient Response at reference conditions

All values are limit values and refers to the output span. The effects
identified with a * on the zero (pe = 0) and the long-term drift are with
reference to the maximum span and are to be multiplied by the
turn-down factor.

Conformity

including hysteresis and
dead band, terminal-based0.2 %¹⁾

Hysteresis

0.1 %¹⁾

Dead band

0.02 %

Power supply

voltage effect per volt

0.005 %

Effect of ambient temperature per 10 K
between -10 °C to +60 °C

* on zero

0.2 %

on span

0.15 %

* Long-term drift per 6 months

0.5 %

* Effect of electro-magnetic interference²⁾

0.2 %

Rise time acc. to DIN 16 086

0.3 s

additional adjustable time constant

0...6.6 s

¹⁾ With adjusted span < 10 mbar, the factor 1.5 is to be taken into
account

²⁾ With high frequency voltage acc. to EN 50 082-2 coupled directly
onto unscreened cables at frequencies ≤ 4 MHz to 3 V; at higher
frequencies or with screened cable to 10 V.

12 Compliance with Pressure Guide Line (97/23/EG)

12.1 Devices with PS \geq 200 bar

Devices with a permissible pressure PS > 200 bar have been subject to a conformity validation by TÜV NORD (0045) acc. to module H. They may be used for liquids of group 1 (PED: 1G).

The data label contents the following specifications:

PED: 1G →

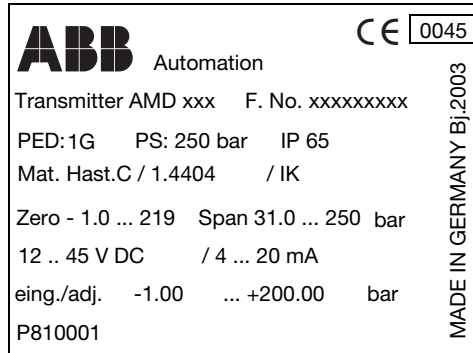

← **CE 0045**

12.2 Devices with PS < 200 bar

Devices with a permissible pressure PS < 200 bar correspond to article 3 paragraph (3). They have not been subject to a conformity validation. These instruments were designed and manufactured acc. to the proven and practical engineer experiences (SEP).

The CE-label on the data label does not apply for the pressure device rules.

In this case the data label contents the following specifications:

PED: SEP

13 Dimensional Diagram

Errors and omissions excepted. All dimensions in millimeters (mm).

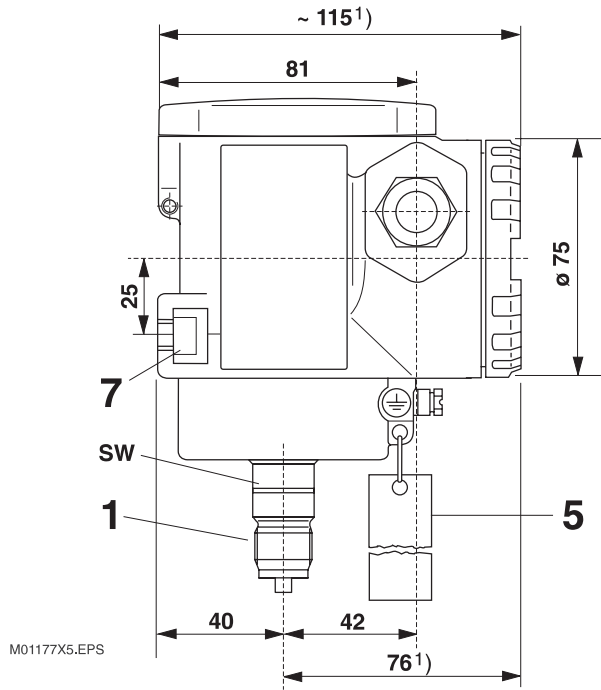
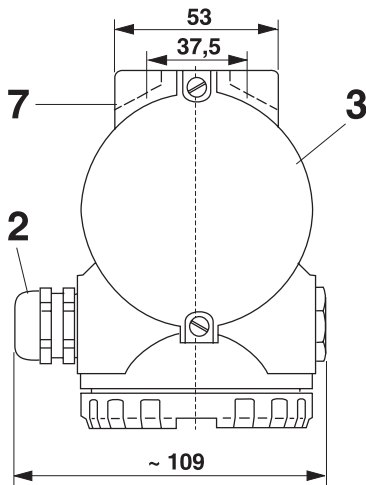
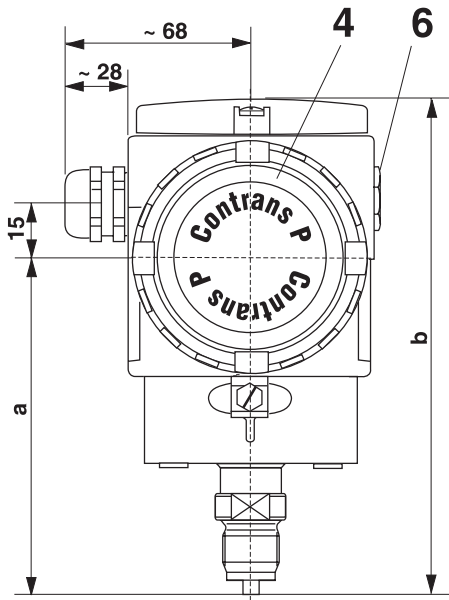

M01177X5.EPS

- SW** (= width across flats in mm):
22mm (standard)
27mm with 1/2-14 female thread process connection and ranges ≤ 250 bar.
36mm with 1/2-14 female thread process connection and 600 bar range.

- 1** Process connection
(DIN 16288 Form B-G1/2A plug is illustrated)
2 Electrical connection:
Pg 13.5 cable gland
or two cable glands, one each right and left
or 1/2-14 NPT female threads one each side
or one Han 8 U plug connector.
3 Type plate.
4 Srew cover.
5 Tie-on plate, e.g. for tag number (optional).
6 Sealing plug.
7 Groove for screws when wall or pipe mounting.

¹⁾ Plus 15 mm for design with indicating instrument.

Process connection: Front bonded diaphragm

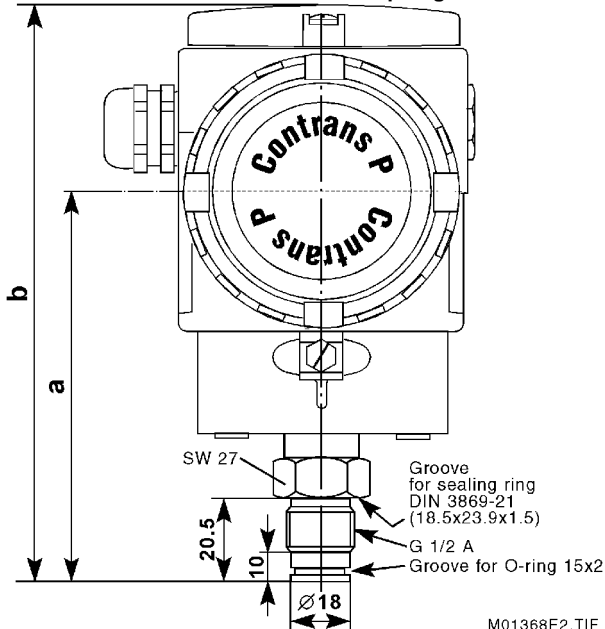

M01368E2.TIF

Dimensions "a" and "b" are dependent upon the transmitter and the process connection.

Process connection	AMD 220		AMD 200	
	"a"	"b"	"a"	"b"
DIN 16 288-Form B spigot	101	151	101	151
1/2-14 NPT female thread	97	147	97	147
Front bonded diaphragm	100.5	150.5	100.5	150.5
1/2-14 NPT male thread	105	155	105	155
G 1/2-Form D spigot for convex seal	111	161	111	161
1/2-14 NPT female thread and 600 bar range	--	--	130	180

Design with one Han 8U connecting plug

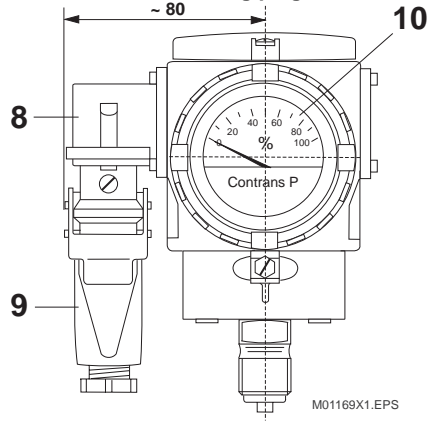

- 8 Han 8U plug connector.
- 9 Equipment socket.
(supplied with plug connector design).
- 10 Indicating instrument (optional).

Possible mounting with mounting bracket (optional)

Vertical pipe mounting

(perm. pipe diameter is 53...64mm)

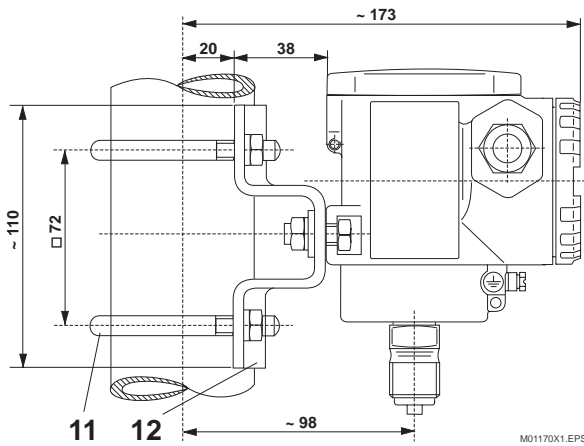

Wall mounting

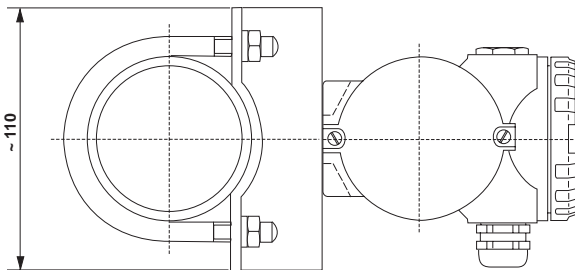
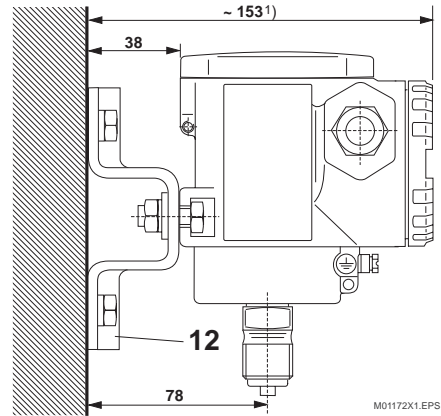

Horizontal pipe mounting

(perm. pipe diameter is 53...64mm)

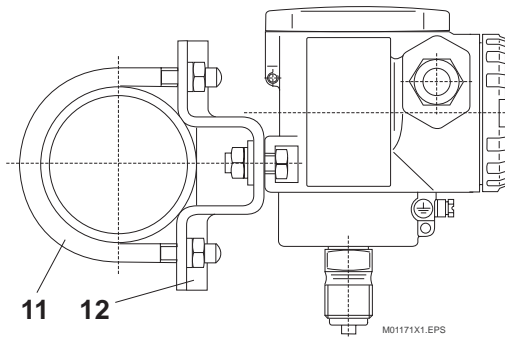

- 11 U-bolts for 2" pipe mounting (optional).
- 12 Mounting bracket, 11mm diameter holes (optional).

¹⁾ Plus 15 mm for design with indicating instrument.

This Technical Documentation is subject to copyright. Translation, reproduction and distribution in any form even as a revised version or in extracts is forbidden without prior permission of the holder of rights; particularly reprint, photomechanical or electronic reproduction and storage in data processing systems or data networks is not allowed. Offenders will be prosecuted and civil action brought against them.



ABB Automation Products GmbH

Schillerstraße 72
D-32425 Minden
Tel. (05 71) 8 30 - 0
Fax (05 71) 830 - 18 46
<http://www.abb.de/automation>

Subject to technical changes
Printed in the Fed. Rep. of Germany
42/15-536-12 EN 02.2003