

Commander SK

Simplicity with Functiona



Snap in Fieldbus
or I/O options
such as EtherNet/IP or
“Real-Time” clock I/O
with Solution Modules



Add PLC functionality
with the
LogicStick

lity



- Easy keypad control
- Top 10 parameters on cover
- SmartStick parameter cloning
- Built-in EMC filter and DB transistor
- Industry-leading two-year warranty and all major approvals

*The new 3Ø size D Commander SK
5 hp @ 230V, 10 hp @ 460V*

Actual size : H=11.81", W=4.53", D=7.80"

Commander SK Overview

Simplicity with Functionality

OPERATOR INTERFACE



EXTERNAL PLC CONTROL

CONTROL MODE

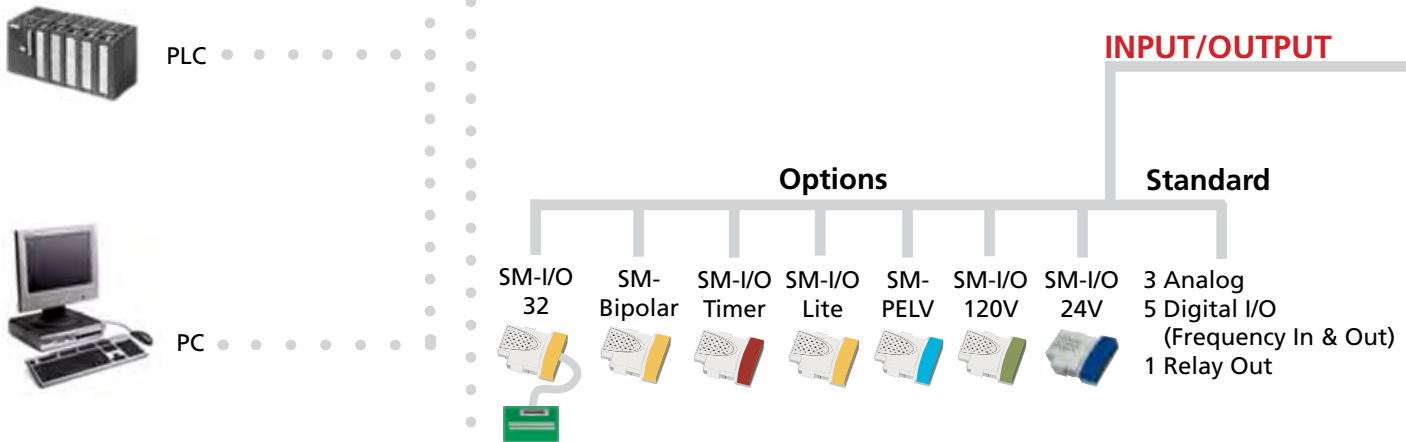

FILTERS

V/Hz / Open Loop Vector



Standard

Options



DYNAMIC BRAKING



Zero Space Internal
Brake Resistor
E-Stop Duty
(size 2 only)

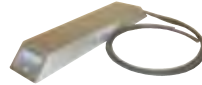

Dynamic Brake Resistors



APPLICATIONS WITH PLC FUNCTIONALITY



LogicStick

Programming Platform



Standard

PLC Functionality
Features
Function Block Programming
Ladder Logic Sequencing

COMMUNICATIONS

Standard

Options



Modbus RTU



DeviceNet



EtherNet/IP
Modbus TCP/IP



EtherCAT



Commander SK

Simplicity with Functionality

Commander SK has been designed to be a simple, compact, cost effective AC motor speed controller that delivers performance with simplicity and ease of use. With all the parameters you need for 90% of applications printed on the front of the drive, Commander SK ensures installation and commissioning are straight forward.

However, for more demanding applications, Commander SK can deliver benchmark functionality at no added cost to the base drive itself. Plug-in options, dynamic performance, PLC functionality and other advanced features ensure that in more complex applications the Commander SK can deliver more than the average general purpose drive - giving you lower cost solutions and better productivity in your motor control applications.



TYPICAL APPLICATIONS

Pump
Accurate Control

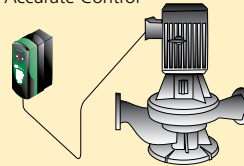

Material Payoff
Performance

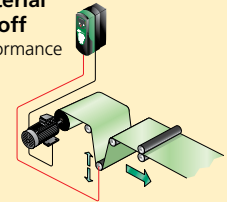

Fan
Energy Saving

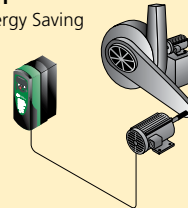

Multiple Motor
Open Loop V/Hz

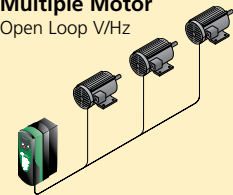

Extruder
Reliability

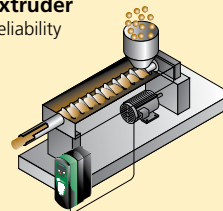

Conveyor
Smooth Acceleration

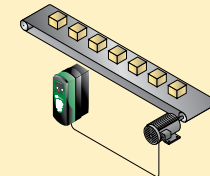

Mixer
Simple and Easy

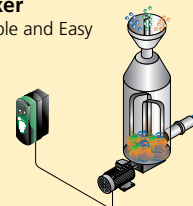

- 0.3 to 1.5 hp (0.25 to 1.1 kW), 1Ø 100-120 VAC
- 0.3 to 3 hp (0.25 to 2.2 kW), 1Ø 200-240 VAC
- 1.5 to 40 hp (1.1 to 22 kW), 3Ø 200-240 VAC
- 0.5 to 200 hp (0.37 to 110 kW), 3Ø 380-480 VAC
- 3 to 150 hp (2.2 to 90 kW), 3Ø 575 VAC
- 25 to 175 hp (15 to 110 kW), 3Ø 690 VAC
- Easy to set-up – all the parameters you need (90% of typical applications) are printed on the front
- Easy installation – choose between simple panel mounting and DIN-rail mounting (up to 2 hp)
- Simple connections – easy access terminals with clear marking
- Simple start-up – easy push button set-up - no need for complex programming
- Communications – Modbus RTU standard, Fieldbus Options; Profibus-DP, EtherCAT, INTERBUS, DeviceNet, CANopen, Ethernet
- PLC Functionality– LogicStick and IEC61131-3 ladder and function block programming
- Wide range of I/O – extra I/O options available including Real-Time Clock
- Performance – high performance open loop vector and torque control

FEATURE

Performance Advantage

Open loop vector control with true space vector modulation

Precise control algorithm provides full torque down to 1 Hz for exceptional performance

Access to multiple parameter levels

Customizes the drive to meet each user's needs: simple (level 1), flexible (level 2) and advanced (level 3)

Top ten level 1 parameters listed on the drive's front cover

On-the-spot easy reference for drive set-up and maintenance

Static auto-tune

Allows fast motor / drive optimization without motor shaft rotation

Two sets of motor map parameters saved in the drive's memory

Allows sequenced switching between two motors with different operating characteristics

Configurable analog and digital I/O

Customizes drive to the specific application

S-ramp accel / decel profiling

Provides smooth speed transitions, minimizing machine "jerk"

Built-in independent PID control

Eliminates the need for an external PID controller while providing "outer loop" control of a process variable

Real-Time Clock option

For scheduling and timing operations

Wide range of industry standard fieldbuses

Modbus RTU (Standard), Profibus-DP, INTERBUS, DeviceNet, CANopen, Ethernet, EtherCAT



Additional Plug-in Functionality

SmartStick

The SmartStick cloning module provides fast and cost-effective drive-to-drive parameter transfer and storage without a PC.

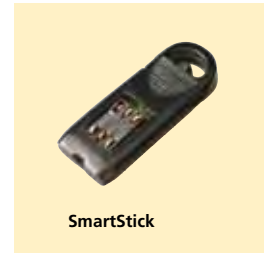

LogicStick PLC Funtionality

Replace nano and micro PLCs by using LogicStick and IEC61131-3 ladder and function block programming.



Fieldbus Communications

The available fieldbus options are Profibus DP, INTERBUS, DeviceNet, CANopen, EtherCAT and Ethernet.



Expandable I/O

In addition to the standard built-in I/O a wide range of I/O options including the new SM-I/O 32 are available to greatly increase the capabilities of the Commander SK.

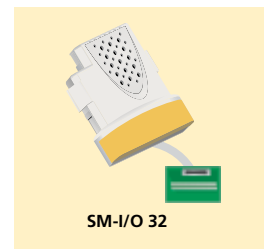

READY TO RUN RIGHT OUT OF THE BOX!

Commander SK comes from the factory preset to operate in V/Hz, and takes only minutes to have up and running:

- 1 Mount the drive
- 2 Wire up the motor
- 3 Wire up the power
- 4 Hardware enable the drive by placing a jumper between B2 and B4
- 5 Provide input power
- 6 Verify rated motor Amps and Volts settings
- 7 Press the Start button to run
- 8 Press Up or Down arrows to set the speed

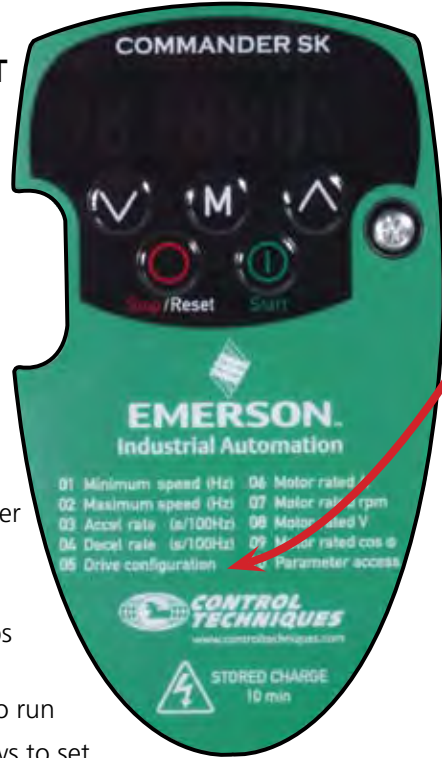

SECONDS TO RECONFIGURE...

To change the drive to another configuration is a simple and fast process. For example, if you want to set the drive to the HVAC (Hand-off-auto) preset, simply:

- 1 Press the Mode button (M)
- 2 Press the Up Arrow (^) until you reach parameter 05, Drive Configuration
- 3 Select by pressing the Mode button (M)
- 4 Press the Up Arrow through the available preset configurations until you see HVAC
- 5 Press the Mode button (M) to select HVAC
- 6 Press the Stop/Reset button and the default HVAC configuration is set

Display Keypad included as standard, Remote Keypad optional

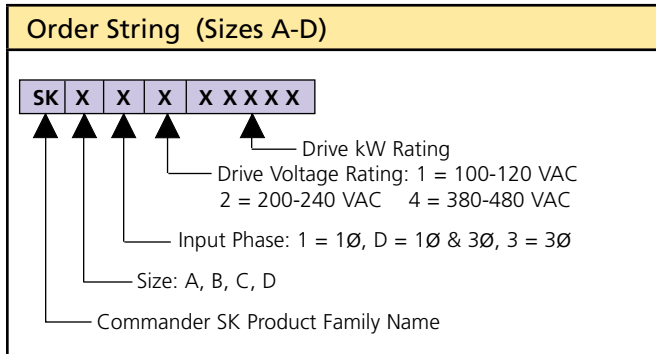

Note: Drive must be disabled (B2 & B4 open) to change the drive's configuration.

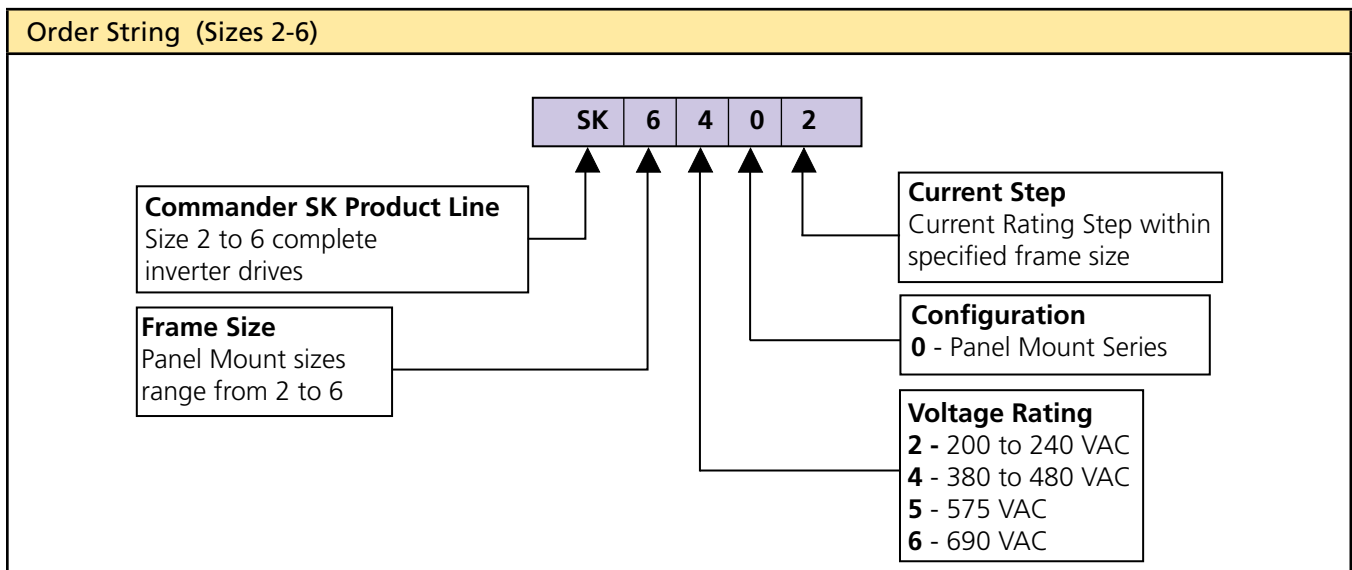

COMMANDER SK RATINGS

100 / 120 VAC ±10% 1Ø (230V 3Ø output)	Normal Duty			Heavy Duty		
	Motor Power (HP)	Max Continuous Current (A)	Typical Output (kW)	Motor Power (HP)	Max Continuous Current (A)	Typical Output (kW)
Order Code						
SKA1100025	.33	1.7	0.25	.33	1.7	0.25
SKA1100037	.5	2.2	0.37	.5	2.2	0.37
SKB1100075	1	4	0.75	1	4	0.75
SKB1100110	1.5	5.2	1.1	1.5	5.2	1.1

200 / 240 VAC ±10% 1Ø (230V 3Ø output)	Normal Duty			Heavy Duty		
	Motor Power (HP)	Max Continuous Current (A)	Typical Output (kW)	Motor Power (HP)	Max Continuous Current (A)	Typical Output (kW)
Order Code						
SKA1200025	0.33	1.7	0.25	0.33	1.7	0.25
SKA1200037	0.5	2.2	0.37	0.5	2.2	0.37
SKA1200055	0.75	3	0.55	0.75	3	0.55
SKA1200075	1	4	0.75	1	4	0.75
SKBD200110	1.5	5.2	1.1	1.5	5.2	1.1
SKBD200150	2	7	1.5	2	7	1.5
SKCD200220	3	9.6	2.2	3	9.6	2.2
SKDD200300	3	12.6	3	3	12.6	3

200 / 240 VAC ±10% 3Ø	Normal Duty			Heavy Duty		
	Motor Power (HP)	Max Continuous Current (A)	Typical Output (kW)	Motor Power (HP)	Max Continuous Current (A)	Typical Output (kW)
Order Code						
SKBD200110	1.5	5.2	1.1	1.5	5.2	1.1
SKBD200150	2	7	1.5	2	7	1.5
SKCD200220	3	9.6	2.2	3	9.6	2.2
SKDD200300	3	12.6	3	3	12.6	3
SKD3200400	5	17	4	5	17	3
SK2201	5	15.5	4	3	12.6	3
SK2202	7.5	22	5.5	5	17	4
SK2203	10	28	7.5	7.5	25	5.5
SK3201	15	42	11	10	31	7.5
SK3202	20	54	15	15	42	11
SK4201	25	68	18.5	20	56	15
SK4202	30	80	22	25	68	18.5
SK4203	40	104	30	30	80	22

575 VAC ±10% 3Ø	Normal Duty			Heavy Duty		
	Motor Power (HP)	Max Continuous Current (A)	Typical Output (kW)	Motor Power (HP)	Max Continuous Current (A)	Typical Output (kW)
Order Code						
SK3501	3	5.4	3	2	4.1	2.2
SK3502	5	6.1	4	3	5.4	3
SK3503	7.5	8.4	5.5	5	6.1	4
SK3504	10	11	7.5	7.5	9.5	5.5
SK3505	15	16	11	10	12	7.5
SK3506	20	22	15	15	18	11
SK3507	25	27	18.5	20	22	15
SK4603	30	36	22	25	27	18.5
SK4604	40	43	30	30	36	22
SK4605	50	52	37	40	43	30
SK4606	60	62	45	50	52	37
SK5601	75	84	55	60	63	45
SK5602	100	99	75	75	85	55
SK6601 ¹	125	125	90	100	100	75
SK6602 ¹	150	144	110	125	125	90

NEW Higher horse power
Commander SK models
now to 200 hp and new
extended 110V range

380 / 480 VAC ±10% 3Ø	Normal Duty			Heavy Duty		
	Motor Power (HP)	Max Continuous Current (A)	Typical Output (kW)	Motor Power (HP)	Max Continuous Current (A)	Typical Output (kW)
Order Code						
SKB3400037	0.5	1.3	0.37	0.5	1.3	0.37
SKB3400055	0.75	1.7	0.55	0.75	1.7	0.55
SKB3400075	1	2.1	0.75	1	2.1	0.75
SKB3400110	1.5	2.8	1.1	1.5	2.8	1.1
SKB3400150	2	3.8	1.5	2	3.8	1.5
SKC3400220	3	5.1	2.2	3	5.1	2.2
SKC3400400	5	9	4	5	9	4
SKD3400550	7.5	13	5.5	7.5	13	5.5
SKD3400750	10	16.5	7.5	10	16.5	7.5
SK2401	10	15.3	7.5	7.5	13	5.5
SK2402	15	21	11	10	16.5	7.5
SK2403	20	29	15	20	25	11
SK2404	20	29	15	20	29	15
SK3401	25	35	18.5	25	32	15
SK3402	30	43	22	30	40	18.5
SK3403	40	56	30	30	46	22
SK4401	50	68	37	50	60	30
SK4402	60	83	45	60	74	37
SK4403	75	104	55	75	96	45
SK5401	100	138	75	100	124	55
SK5402	125	168	90	125	156	75
SK6401 ¹	150	205	110	150	180	90
SK6402 ¹	200	236	132	150	210	110

690 VAC ±10% 3Ø	Normal Duty			Heavy Duty		
	Motor Power (HP)	Max Continuous Current (A)	Typical Output (kW)	Motor Power (HP)	Max Continuous Current (A)	Typical Output (kW)
Order Code						
SK4601	25	22	18.5	20	19	15
SK4602	30	27	22	25	22	18.5
SK4603	40	36	30	30	27	22
SK4604	50	43	37	40	36	30
SK4605	60	52	45	50	43	37
SK4606	75	62	55	60	52	45
SK5601	100	84	75	75	63	55
SK5602	125	99	90	100	85	75
SK6601 ¹	150	125	110	125	100	90
SK6602 ¹	175	144	132	150	125	110

Normal Duty	For applications that use self-ventilated induction motors and require a low overload capability (e.g. fans, pumps)
Heavy Duty	150% overload current for 60 seconds. For constant torque applications that require a high overload capability (e.g. cranes, hoists).

1) Size 6 drives require a +24VDC - 3.5A power supply for the heat sink fans not provided with unit. See the Options & Accessories section for available power supplies.

COMMANDER SK TERMINAL DIAGRAM

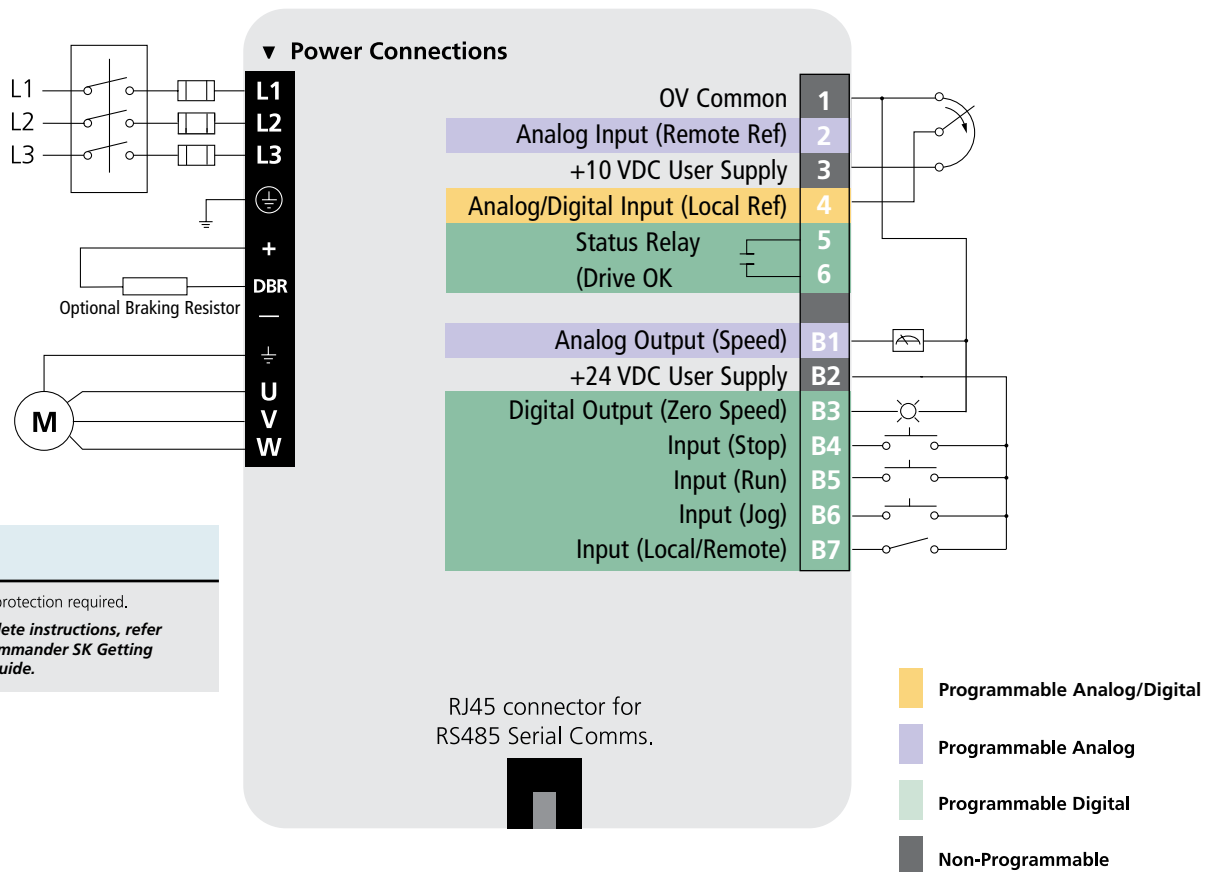

NOTE

* Thermal protection required.
For complete instructions, refer to the Commander SK Getting Started Guide.

TERMINAL DESCRIPTION

Pin	Function ①	Type/Description	Notes
T1	0V Common	Common for External Analog Signals	
T2 ①	Analog Input 1 (A1) either voltage or current	Remote Speed Reference Input 4-20 mA	
T3	+10 VDC	Reference Supply	5 mA max Short Circuit Protected
T4	Analog Input 2 (A2) or Digital Input	Local Speed Reference Input 0-10V	0 to +10 VDC (AI) 0 to +24 VDC (DI)
T5 T6	Status Relay (Normally open)	Drive Healthy	240 VAC 30 VDC 2A/6A resistance
B1	Analog Output 1 single ended Unipolar	Motor Speed	0 to +10 VDC @ 5 mA max
B2	+24 VDC Output	User Supply	100 mA max
B3	Digital Input/Output Pulse Output	Zero Speed	0 to +24 VDC, Pulse Output to 10 kHz

Pin	Function ①	Type/Description	Notes
B4	Stop	Digital Input	0 to +24 VDC
B5	Run	Digital Input	0 to +24 VDC,
B6	Jog	Digital Input	0 to +24 VDC,
B7	Local/Remote Speed Reference Select A1/A2	Digital Input / Pulse Input	0 to +24 VDC, Pulse Input to 50 kHz

① 4-20, 20-4, 20-0 mA are also available. See Commander SK Getting Started Guide.

Values in parenthesis designate functions when #5 = AI.AV
 Drive default is keypad mode #5 = PA

COMMANDER SK SPECIFICATIONS

Environment

IP20

UL TYPE 1 or NEMA 1 rating with optional cover + conduit entry kit

Ambient temperature -10°C to +40°C @ 3 kHz switching

Operation to +50°C/+55°C with de-rating

Humidity 95% maximum (non-condensing)

Electromagnetic Immunity complies with EN61800-3 and EN61000-6-3 and 4

Electromagnetic Emissions complies with EN61800-3 (second environment) as standard. Complies with EN61000-6-3 (residential) and EN61000-6-4 (industrial) generic standards with optional footprint EMC filter

Control

Open loop vector control, V/Hz

Speed or torque control

Reference input: 0-10V, 0-20 mA, 4-20 mA, 8 Presets, Pulse, PWM (-10 to +10V SM-Bipolar option)

Digital I/O - All configurable

4 inputs, not stop, run, jog, local/remote (default)

1 I/O zero speed (default)

1 relay drive health (default)

Switching frequency: 3 kHz (default)

230V: 6, 12, 18 kHz

460V: 6, 12 kHz

Output frequency 0 to 1500 Hz

Accel and Decel ramps (linear and S type)

Positive logic control

Serial communication

Modbus RTU RS485 via RJ45 connector

Baud rate 4800, 9600, 19200 or 38400 bits per second

DC injection braking as standard

Dynamic braking transistor as standard (except SKA1100025 & SKA1100037)

Dynamic motor V/Hz for energy saving

Quadratic motor V/Hz for fan and pump optimization

Protection

Undervoltage, Supply and DC link overvoltage, Phase loss, Drive overload, Instantaneous overcurrent, Short circuit, Ground fault, Drive thermal, Watchdog, Motor thermal

General Characteristics

Maximum overload 150% of rated current for 60 seconds

Intelligent Thermal Management (ITM) optimizes switching frequency

Catch a spinning motor

Power loss ride through

Automatic no-spin auto-tune for fast performance optimization

Keypad access to all parameters for more demanding applications

Approvals & Listings

UL, cUL UL File #E171230

IEC Meets IEC Vibration, Mechanical Shock and Electromagnetic Immunity Standards

CE Low Voltage Directive

UL UL type 1 with kit

ISO 9001:2000 Certified Manufacturing Facility

ISO 14001 Certified Manufacturing Facility

COMMANDER SK DIMENSIONS

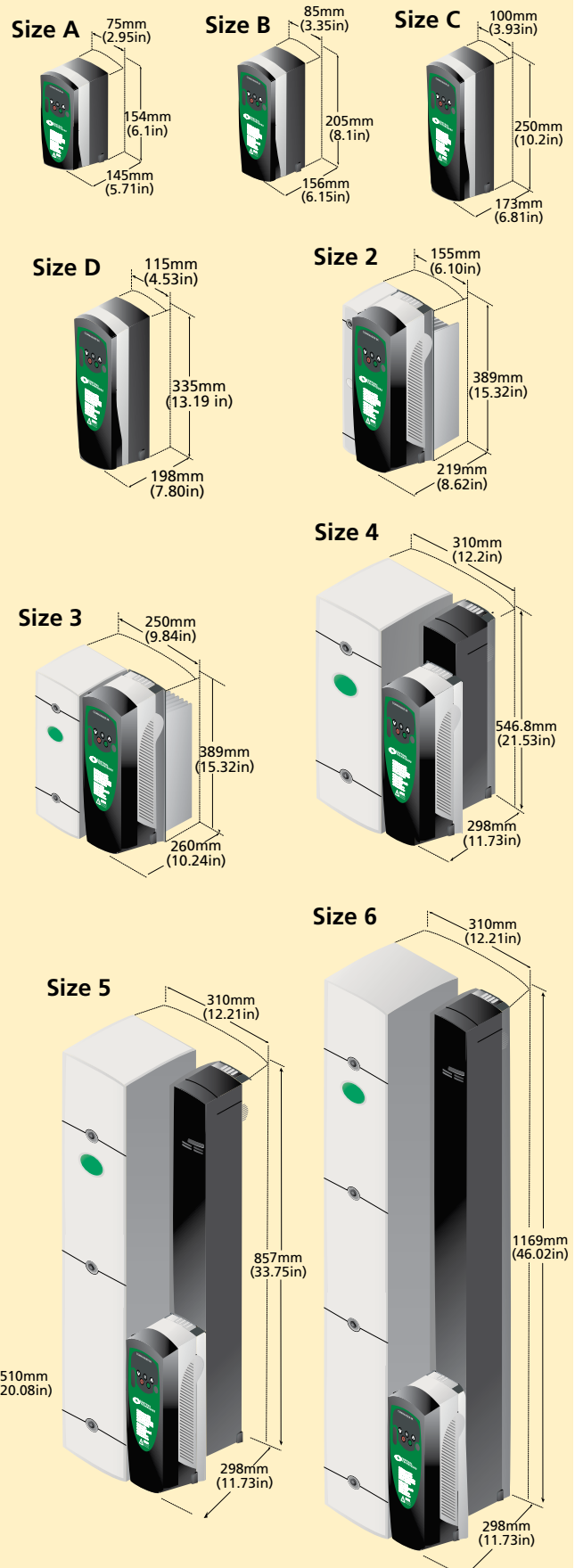

Commander SK

Options

Commander SK has been designed to offer simplicity with an impressive selection of options and standard features. It also offers functionality that enables users to get more productivity from their machines.

Users that scratch the surface of this simple drive will discover a list of dynamic and functional options that owe much to the ground breaking Solution Platform products, such as Unidrive SP, in the Control Techniques product portfolio.

Plug in the power of a PLC!



OPTIONS AT-A-GLANCE

Option	Description	Order Code
Drive Configuration & Programming	Configuration Tool	CTSOFT
	Keypad to Drive Cable	SP-LCD-485-XXX
	RS232/485 Cable	CT-COMMS-CABLE
	USB Cable	CT-USB-CABLE
	Cloning and parameter storage	SMARTSTICK
Operator Interfaces	Remote LED display	SK-KEYPAD REMOTE
	Remote LCD display	SM-KEYPAD PLUS
	HMI Operator Interfaces	See AC Options & Accessories
Power Accessories	Internal EMC Filter	Standard
	External EMC Filter	See the Options & Accessories section
	Braking Resistor	See the Options & Accessories section
Environmental Protection and Cable Management Options	Top & Side covers and conduit entry	SK-NEMA1-KIT-A, B, C OR D
	Conduit Boxes sizes 2-6	See AC Options & Accessories
Input/Output Size B and up accept up to one SM total	Extended I/O	SM-I/O LITE
	Extended I/O	SM-I/O-32
	Extended I/O plus Real Time Clock	SM-I/O-TIMER
	Double Insulated Extended I/O	SM-I/O-PELV
	120V Extended I/O	SM-I/O-120V
	24V Protected I/O	SM-I/O-24V
	Bipolar Reference	SM-BIPOLAR
Communications Size B and up accept up to one SM total	Modbus RTU	Standard
	PROFIBUS DP	SM-PROFIBUS-DP
	DeviceNet	SM-DEVICENET
	CANopen	SM-CANOPEN
	Interbus-S	SM-INTERBUS
	Ethernet	SM-ETHERNET
	Ethernet (EtherCAT)	SM-ETHERCAT
Application Programming Software (IEC61131-3)	Ladder and function block programming	SYPTLITE
	Memory for SyPTLite program	LOGICSTICK



Drive Configuration and Parameter Programming

DRIVE CONFIGURATION TOOL

CTSoft software is a free Windows-based drive configuration tool designed to enable the complete control and display of all parameters within a Commander SK. Functions within CTSoft allow data to be uploaded, viewed, saved, or retrieved from disk, modified and printed. It can be used offline in the office or online in the factory. CTSoft communicates with the Commander SK via the computer's serial port to the drive's RS485 port using a communications cable (CT-Comms-Cable or CT-USB-Cable).

Some of CTSoft's capabilities include:

- Remote Upload/Download
- Parameter Saving
- Monitor Screens
- Multiple Window Display
- Block Diagram Animation
- Project Storage

SMARTSTICK

This option enables the simple set up of parameters in a variety of ways. The SmartStick can:

- 'Clone' a complete set of parameters from the first drive to multiple drives (ideal for serial production)
- Download parameter settings to the drive to easily set up your application
- Automatically save the user parameter set up for storage and maintenance purposes
- Load complete motor map parameters



The SmartStick may be "hot swapped".

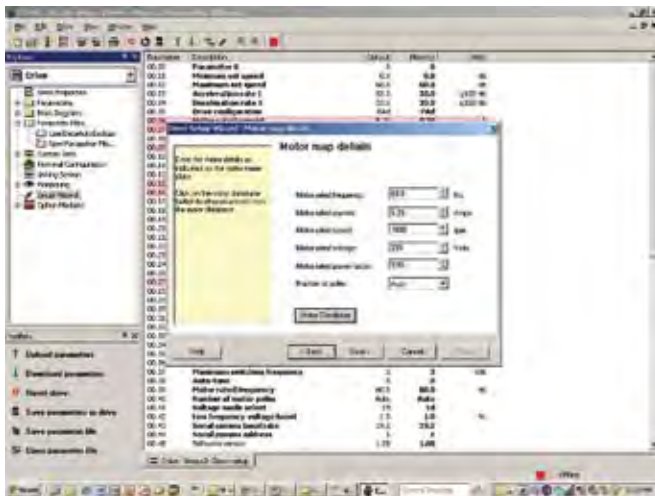

Operator Interfaces

KEYPAD OPTIONS

The Commander SK can be configured or operated using the standard fixed keypad, or with either the SK-Keypad Remote or SM-Keypad Plus. The SK-Keypad Remote is a NEMA12 (IP65) full-function, 7-digit LED data display with an additional multi-function push button. The SM-Keypad-Plus is a back-lit LCD display option that can be remote mounted, has 5 languages, plus custom text database, online help, and HMI features.



SK-Keypad Remote



SM-Keypad Plus

Multi-lingual

English
French
Spanish
German
Italian

Keypad to Drive Cable SP-LCD-485-XXX
XXX=005, 010, 015, 025, 050 feet

HUMAN MACHINE INTERFACE (HMI)

These operator interface units complement the product line by offering an impressive way of accessing parameters and adding more programming power to your application.



For more information, refer to the Accessories Section.

Power Accessories

DYNAMIC BRAKING RESISTORS

Dynamic braking resistors provide a means of rapidly decelerating or stopping the motor and load. The mechanical energy stored in the spinning mass is converted into electrical energy by the drive and then quickly dissipated into the resistor. Internal, panel mount and enclosed version are available.



See the Options & Accessories section for complete braking resistor ratings, model numbers and order codes.

EMC FILTERS

An internal EMC filter is provided as standard with the Commander SK which is adequate for most industrial applications. The drive and filter conforms to EN61800-3 (second environment). For installations where it is deemed necessary, Control Techniques provide a range of additional external EMC filters. The internal filter can be easily removed if the drive is to be used on IT supplies or with low earth leakage external EMC Footprint filters.



External EMC filters are used to minimize high frequency power supply line disturbances caused by PWM AC drives that may interfere with proper operation of sensitive electronic equipment. The Commander SK EMC filters are designed such that they can be mounted in either of two orientations.

- Bookend: filter mounts next to the drive with the smallest dimension being the width of the filter
- Footprint: filter mounts between the drive heatsink and the panel or enclosure

Note: Refer to the Options & Accessories section in the back of the catalog for complete details on all EMC filters including low leakage filters.

TOP COVER OPTIONS

A plastic top cover can be fitted to the Commander SK. This cover simply clips onto the top of the drive for protection from falling particles. The top cover provides protection to IP4X per IEC specification.

NEMA 1 KIT

The NEMA 1 Kit includes a Top Cover, Side Covers, and a Conduit Entry Box providing a UL Type 1 Plenum rating. With this option Commander SK drives can be mounted into air handling ducts.



Sizes A-D
SK-NEMA1-KIT-A, B, C or D

CONDUIT BOXES

Conduit plates for Commander SK, Commander GP20 and Unidrive SP wall-mount drives.

For overall dimensions and order codes see the [AC Options & Accessories section page 83](#).

Description	Order Code
Plastic Top & Side Covers	SK-COVER-A, SK-COVER-B, SK-COVER-C, SK-COVER-D
UL Type 1 Rating Kit	SK-NEMA1-KIT-A, SK-NEMA1-KIT-B, SK-NEMA1-KIT-C, SK-NEMA1-KIT-D
Conduit Boxes sizes 2-6	C-BOX-S2, C-BOX-S3, C-BOX-S4, C-BOX-S5, C-BOX-S6

I/O OPTIONS

SM-BIPOLAR (Commander SK only)

This module provides an optional bipolar speed reference input card for the Commander SK. It allows the direction of rotation of a motor to be controlled via an analog signal rather than the run forward and run reverse terminals or a forward/reverse terminal.



- ±10V bipolar input
- Relay output

ADDITIONAL I/O OPTIONS*

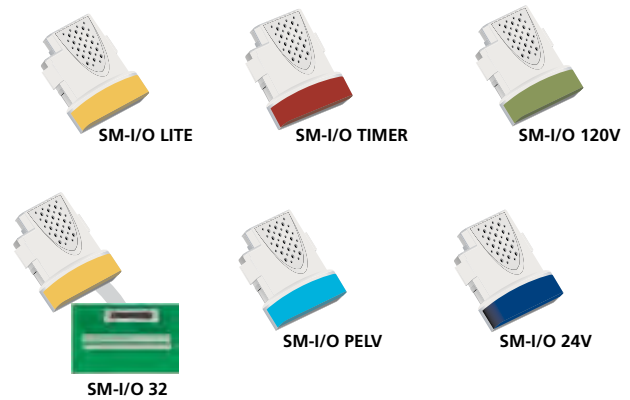

* These SM I/O option modules also work with other Control Techniques drives.

For more details and order codes see the [AC Drive Options section at the end of the AC Drives section](#).

For complete product descriptions please refer to the [Options and Accessories section](#).

COMMUNICATION OPTIONS*

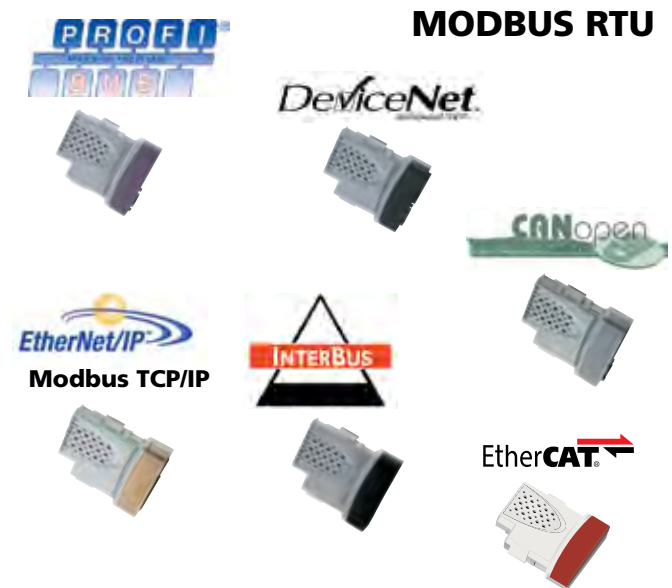

* These SM Communications option modules also work with other Control Techniques drives.

For more details and order codes see the [AC Drive Options section at the end of the AC Drives section](#).

For complete product descriptions please refer to the [Options and Accessories section](#).

PLC Funtionality On-Board

LADDER PROGRAMMING SOFTWARE SyPTLite IEC 61131-3

SyPTLite is a ladder diagram editor that allows you to develop programs that can be executed onboard Commander SK with a LogicStick.

SyPTLite is designed to meet the needs of the majority of automation users wishing to extend the functionality of the drive control and sequencing. The software has been developed with a definite focus on intuitive ease of use allowing you to quickly access all of the drive's parameters and to monitor and debug your ladder program online.

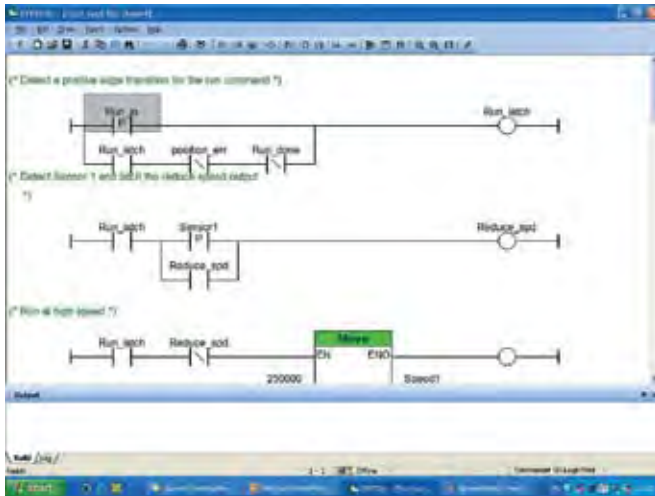

Programming Software

SyPTLite with LogicStick

Commander SK is Control Techniques' simple and easy-to-use general-purpose drive. However, Commander SK contains features and functions that you may not expect to find on a low-cost drive, such as the flexibility to program PLC applications onboard the drive. By inserting a LogicStick into the front of the drive, you quickly add memory for program storage that allows you to write a PLC ladder program using SyPTLite. The drive is prioritized to execute all motor control related functions first and will use any remaining processing time to execute the SyPTLite ladder program as a background activity. Inset shows strap used to secure the LogicStick.



Description	Order Code
The LogicStick plugs into the front of the drive and enables you to program PLC functions within the drive. Typically 30-50 rungs of logic.	LOGICSTICK

SyPTLite contains a comprehensive library of functions that is based on those available in the SyPTPro programming tool. These include:

- Arithmetic Blocks
- Comparison Blocks
- Timers
- Counters
- Multiplexers
- Latches
- Bit Manipulation



RAPIDPAK
When you need it FAST!

**One Week
Shipment
Standard**

EMERSON
Industrial Automation

See the RapidPak pages in the Packaged Drives and Engineered Systems section for details.

Commander SK

Specialty Pump Drive Solution



Save energy and control constant pressure with the Commander SK drive that is dedicated to pumping applications. The Commander SK Pump Drive is rich with features that are a perfect match for simplex (single pump) system needs.

The SK Pump Drive is shipped pre-programmed and ready for quick and easy installation. Simply enter the motor parameters, desired control mode, and diagnostic settings and you're up and running! This can be done without a computer through the built-in keypad, or using your PC and our free CTSOft commissioning software.



- Save Energy, Time, and Cost With These Features:
- **Constant Pressure PID**
 - **Auto / Hand Modes**
 - **No Flow Detection**
 - **Dry Well Detection**
 - **Transducer Loss Detection**
 - **Sleep / Wake**
 - **Pipe Fill Start Mode**
 - **Keypad and Terminal Control**
 - **Automatic Fault Reset**
 - **Multiple Pressure Set-points**
 - **Use Pressure Transducer and/or Switch Feedback**



Typical Wiring Diagram:

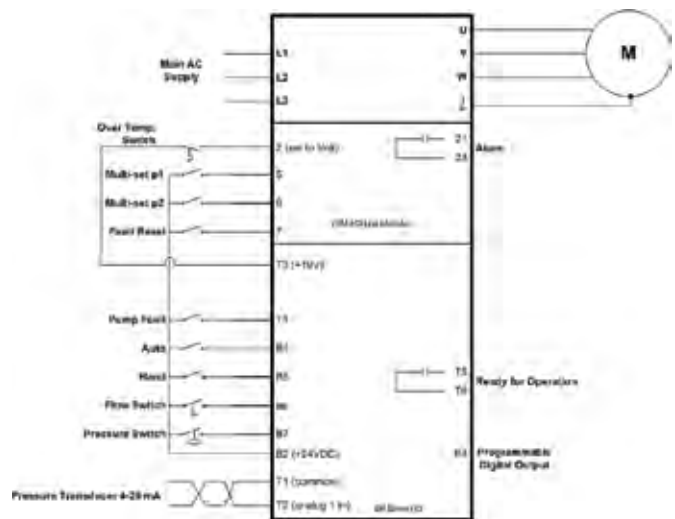

NOTE:

- Pressure Switch Input B7 Only active in Pump Mode 1 18.12 = 1
- Flow Switch Input B6 Only active in Pump Mode 1 18.12 = 1 Or 2
- All outputs are programmable to indicate any alarm, trip or status

Simple Ordering

Adding the suffix **-P** to any SK drive specifies it as a pump drive. Using a **-PL** suffix with any SK drive frame size B or larger, adds an SM-I/O Lite module that allows:

1. Multiple pressure set-point selection via digital inputs
2. An external reset digital input
3. Over temperature digital input
4. One additional programmable relay output

In either case, the drive will be shipped with a pumping specific parameter set, a pre-programmed LogicStick, and a manual.

For anyone wishing to convert an existing SK drive to a Pump version, the pre-programmed LogicStick is available as a separate item. Order Code is **LOGICSTICK-PUMP**.