

COILS AND CONNECTORS



COILS AND CONNECTORS

INTRODUCTION

For each NEM electrically operated valve, indication of coil type is available, the coil must be selected through the technical specification, referring to feeding voltage and connector type.

Here follows some technical definitions of the coil's characteristics.

Feeding voltage

In order to obtain correct functionality and long life of the coil it is strongly recommended to maintain the feeding voltage always at +/-10% of the nominal value.

Thermal insulation class (DIN VDE 0580)

The insulation class of the coil gives max absolute working temperature (T).

Class F - T = 155°C
Class H - T = 185°C

The max absolute working temperature value "T" is the sum of the working temperature ΔT of the coil energized for 1 hour and of the ambient temperature Ta:

$$T = \Delta T + T_a$$

The insulation class of the wire gives the max working temperature inside the coil, before a short circuit damages of the wire insulation.

All NEM coil are produced with "H" class insulation copper wire, with >185°C resistance capability.

ED - Working intermittent (DIN VDE 0580)

Intermittent working (ED) is the max acceptable percentage of energized time "ti" versus the total cycle time "tc" (tc=ti+tr / tr=rest time).

$$ED = (t_i / t_c) * 100 \text{ [100\%]}$$

All coils can be used with ED=100%, as long as the max acceptable insulation class temperature is not exceeded.

Moreover, all NEM proportional coils can be considered as ON-OFF coils with ED=50% if the maximum total cycle time is defined as 5 minutes (according to the DIN VDE 0580).

Protection class (EN60529)

The protection class IP is a code based on two numbers that gives the level of protection for an electric equipment against the acid. or inad. contact with human body or objects and the water resistance. The first value gives the level of protection against external solid objects, the second value gives the level of protection against liquid penetration.

Some example of protection class:

IP RATE	DEFINITION
IP 65	<ul style="list-style-type: none"> Total protection against accid. or inad. contact. Protection against dust. Protection against water (out of a nozzle) from all direction
IP 67	<ul style="list-style-type: none"> Total protection against accid. or inad. contact. Protection against dust. Protection against water plunging

COIL - TUBE Ø 13

22 W

- Wire insulation class.....H (>185°C)
- ED.....100%
- Coil power at 20° C.....22 W
- Ambient temperature.....-20 +40° C
- Weight.....0,19 Kg

ELECTRIC CIRCUITS

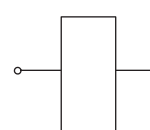

STANDARD

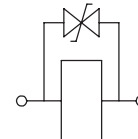

**WITH DIODE
(BI-DIRECTIONAL)**

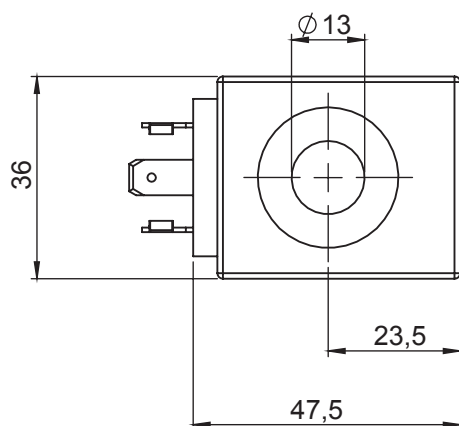
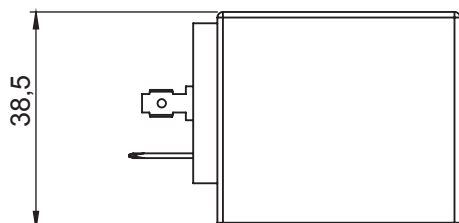

AMP - JUNIOR

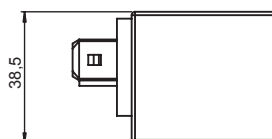

AMP - SUPER SEAL

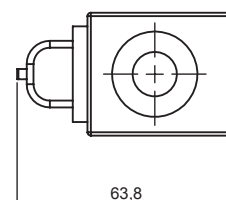
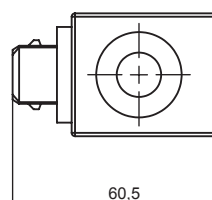
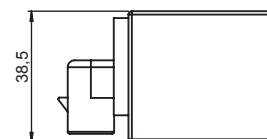

CABLE

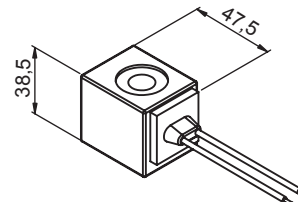

Note:

- Coil interchangeable with CT-9400 model.

CONNECTOR	PROTECTION CLASS	COIL THERMAL INSULATION CLASS	VOLTAGE [V]	RESISTANCE [Ω]	CIRCUIT	ORDERING CODE
DIN 43650	IP65*	F	12 V dc	6,5	STANDARD	092001130
DIN 43650	IP65*	F	14 V dc	8,9	STANDARD	092001132
DIN 43650	IP65*	F	24 V dc	26,5	STANDARD	092002130
DIN 43650	IP65*	F	26 V dc	30,6	STANDARD	092002132
AMP-JUNIOR	IP65*	F	12 V dc	6,5	STANDARD	092201130
AMP-JUNIOR	IP65*	F	24 V dc	26,5	STANDARD	092202130
AMP-JUNIOR	IP65*	H	26 V dc	32,5	WITH DIODE	092202132
CABLE L=300mm	IP65*	F	14 V dc	8,9	STANDARD	092601130
CABLE L=300mm	IP65*	F	26 V dc	30,6	STANDARD	092602130
AMP-SUPER SEAL	IP67*	F	24 V dc	26,5	STANDARD	092702130

* Protection index with standard connector



COIL - TUBE Ø 13

18 W

- Wire insulation class.....H (>185°C)
- ED..... 100%
- Coil power at 20° C.....18 W
- Ambient temperature.....-20 +40° C
- Weight.....0,15 Kg

ELECTRIC CIRCUITS

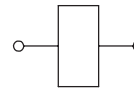

STANDARD

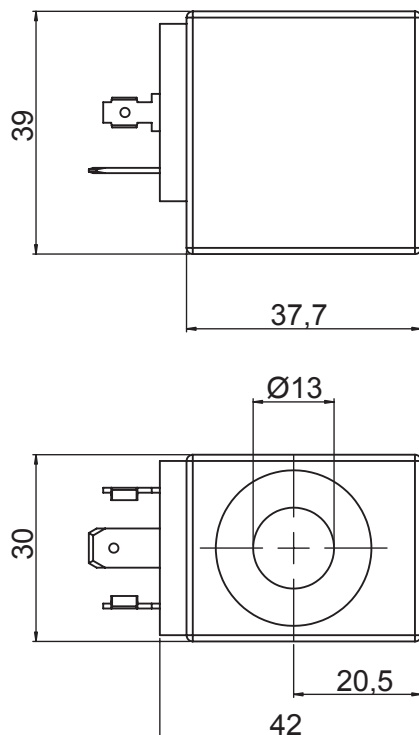

CONNECTOR	PROTECTION CLASS	COIL THERMAL INSULATION CLASS	VOLTAGE [V]	RESISTANCE [Ω]	CIRCUIT	ORDERING CODE
DIN 43650	IP65*	F	12 V dc	7,5	STANDARD	093001131
DIN 43650	IP65*	F	24 V dc	30,1	STANDARD	093002131
DIN 43650	IP65*	F	24 V rac**	25,6	STANDARD	093007130
KOSTAL M27x1	IP65*	F	12 V dc	7,5	STANDARD	093401131
KOSTAL M27x1	IP65*	F	24 V dc	30,1	STANDARD	093402131

* Protection index with standard connector

** Rectifier not included

COIL - TUBE Ø 13

20,5 W

- Wire insulation class.....H (>185°C)
- ED.....100%
- Coil power at 20° C.....20,5 W
- Ambient temperature.....-20 +40° C
- Weight.....0,16 Kg

ELECTRIC CIRCUITS

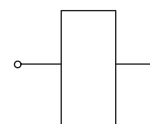

STANDARD

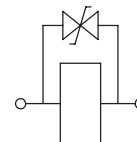

**WITH DIODE
(BI-DIRECTIONAL)**

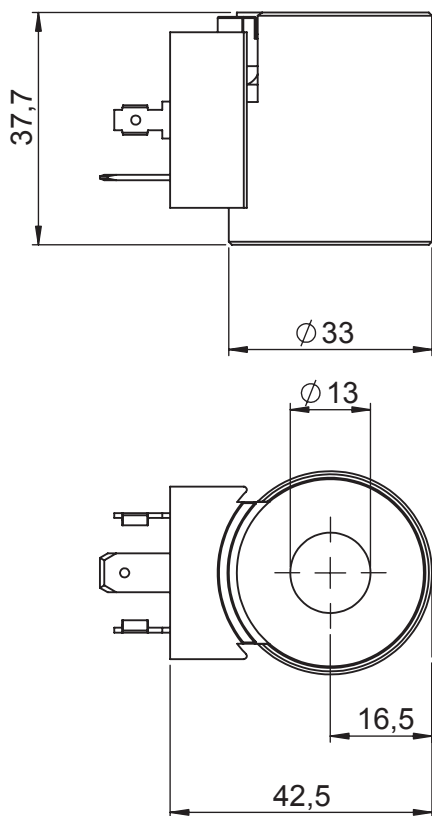

DEUTSCH DT4

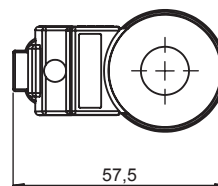
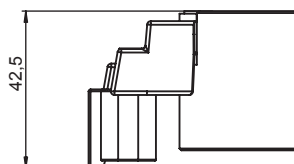

AMP - JUNIOR

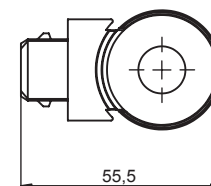
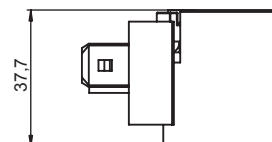

Note:

- Coil interchangeable with CT-9200 model.

CONNECTOR	PROTECTION CLASS	COIL THERMAL INSULATION CLASS	VOLTAGE [V]	RESISTANCE [Ω]	CIRCUIT	ORDERING CODE
DIN 43650	IP65*	H	12 V dc	7	STANDARD	094001000
DIN 43650	IP65*	H	24 V dc	28	STANDARD	094002000
DEUTSCH DT 4	IP67	H	12 V dc	7	WITH DIODE	094101000
DEUTSCH DT 4	IP67	H	24 V dc	28	WITH DIODE	094102000
AMP - JUNIOR	IP65*	H	12 V dc	7	STANDARD	094201000
AMP - JUNIOR	IP65*	H	24 V dc	28	STANDARD	094202000

* Protection index with standard connector



PROPORTIONAL COIL - TUBE Ø 19

36 W

- Wire insulation class.....H (>185°C)
- ED *.....100%
- Coil power at 20° C.....36 W
- Max current at 24 V dc.....0,9 A
- Max current at 12 V dc.....1,8 A
- Ambient temperature.....-20 +40° C
- Weight.....0,28 Kg

* ON/OFF use allowed only with ED 50% max (ED 50% according to the DIN VDE 0580)

ELECTRIC CIRCUITS

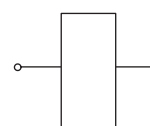

STANDARD

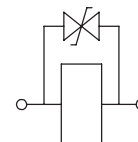

**WITH DIODE
(BI-DIRECTIONAL)**

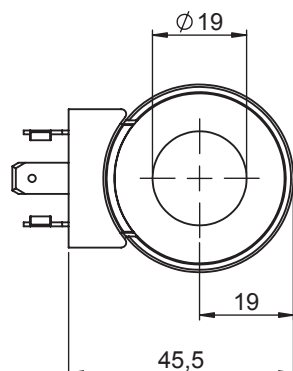
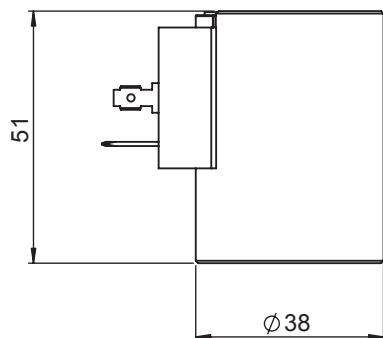

AMP - JUNIOR

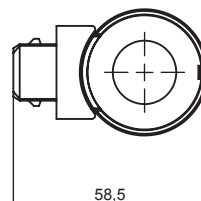
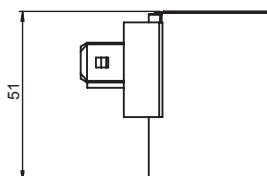

DEUTSCH DT4

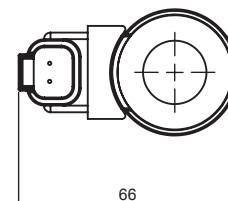
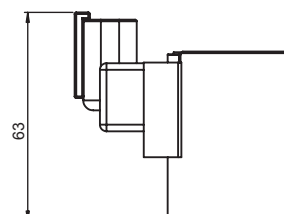

CONNECTOR	PROTECTION CLASS	COIL THERMAL INSULATION CLASS	VOLTAGE [V]	RESISTANCE [Ω]	CIRCUIT	ORDERING CODE
DIN 43650	IP65*	H	12 V dc	3,9	STANDARD	098001190
DIN 43650	IP65*	H	24 V dc	14,5	STANDARD	098002190
DEUTSCH DT 4	IP67	F	12 V dc	3,9	WITH DIODE	098101190
DEUTSCH DT 4	IP67	F	24 V dc	14,5	WITH DIODE	098102190
AMP - JUNIOR	IP65*	F	12 V dc	3,9	WITH DIODE	098201190
AMP - JUNIOR	IP65*	F	24 V dc	14,5	WITH DIODE	098202190
AMP - JUNIOR	IP65*	H	26 V dc	18,8	WITH DIODE	098212192

* Protection index with standard connector

COIL - TUBE Ø 19

24 W

- Wire insulation class.....H (>185°C)
- ED.....100%
- Coil power at 20° C.....24 W
- Ambient temperature.....-20 +40° C
- Weight.....0,28 Kg

ELECTRIC CIRCUITS

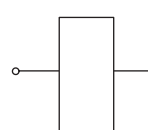

STANDARD

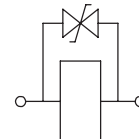

**WITH DIODE
(BI-DIRECTIONAL)**

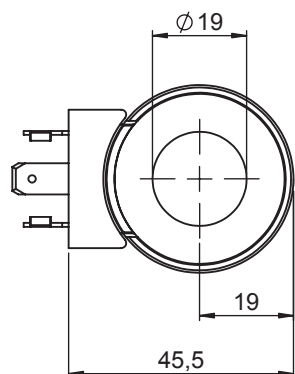
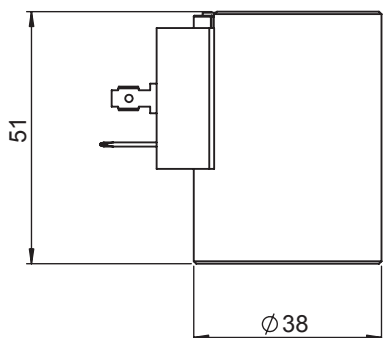

AMP - JUNIOR

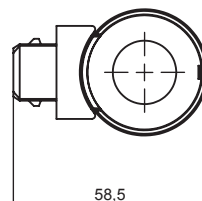
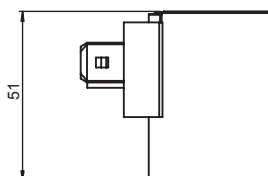

DEUTSCH DT4

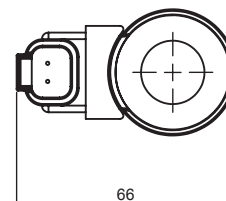
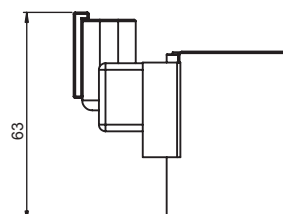

CONNECTOR	PROTECTION CLASS	COIL THERMAL INSULATION CLASS	VOLTAGE [V]	RESISTANCE [Ω]	CIRCUIT	ORDERING CODE
DIN 43650	IP65*	H	12 V dc	6,8	STANDARD	098011190
DIN 43650	IP65*	H	24 V dc	24	STANDARD	098012190
DIN 43650	IP65*	H	26 V dc	27,1	STANDARD	098012191
DIN 43650	IP65*	H	220 V Rac**	1470	STANDARD	098016190
DEUTSCH DT 4	IP67	F	12 V dc	6,8	WITH DIODE	098111190
DEUTSCH DT 4	IP67	F	24 V dc	24	WITH DIODE	098112190
AMP - JUNIOR	IP65*	F	12 V dc	6,8	WITH DIODE	098211190
AMP - JUNIOR	IP65*	F	24 V dc	24	WITH DIODE	098212190
AMP - JUNIOR	IP65*	H	26 V dc	28,1	WITH DIODE	098212193

* Protection index with standard connector

** Rectifier not included - Power 25W



CONNECTOR DIN 43650 - ISO 4400

- Insulation class. **VDE 0110-1/89**
- Protection index. **IP 65**
- Distance between poles **18 mm**
- Poles resistance at 20°C. **6 < Ohm**
- Ambient temperature **-40 +90° C**
- Max conductor cross sett. **1,5 mm**
- Weight. **0,05 Kg**

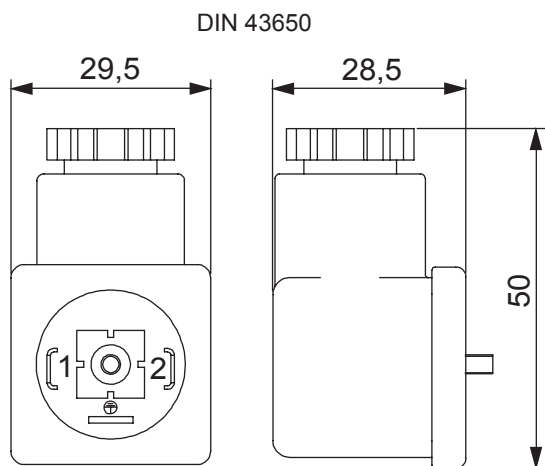

Ordering code

4 3 5 2 2 0 1 0 0 0

NITRILE SEAL

PROPORTIONAL ELECTRIC DRIVER

- Power supply voltage **12-24VDC**
- Rectified and filtered ripple voltage. **10%**
- Output current **0-1,7A**
- Max current absorption without load **30mA**
- Off-set current. **0-1,0A**
- Medium power absorption. **35W**
- Dither frequency. **50-400Hz**
- Ramp up-down time. **0,1-10 S**
- Current stability on temperature range. **3%**
- Maximum time delay of the ramp independently of the full load current setting. **YES**
- Operating temperature range. **-10/+50°C**
- Protection class. **IP65**
- Weight. **100g**

GENERAL DESCRIPTION

This miniature electronic regulator is embedded into the plug housing with DIN43650 - ISO 4400 connector and allows open loop driving of the solenoid of proportional valves. It is protected against power supply polarity inversion and solenoid short circuit. The minimum and maximum current values are adjusted with two potentiometers, and other two separate potentiometers allow the ramp-up and ramp-down parameter adjustment. A yellow led is lit when the system is powered.

NOTE

The power supply voltage must be in the 12 to 24 V DC range. It is necessary to power the system with rectified and filtered voltage. The use of a 4700 mF 35V electrolytic capacitor is recommended to filter the power voltage supply. The electronic controller can drive valves with coil powered at 12 or 24 Vdc. In order to assure the nominal maximum current value of the coil it is necessary that the voltage supply of the controller exceeds the nominal voltage supply of the coil valve at least of 1,5V.

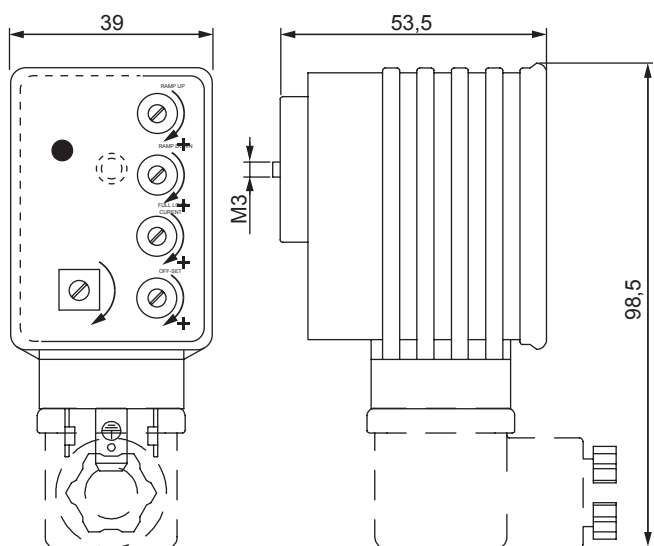

Ordering code

2980010000



PROPORTIONAL ELECTRIC DRIVER

APPLICATIONS

1 - On-Off application mode with switch and ramp setting for acceleration and deceleration uses.

The **GND** and **3** terminals are connected to the two terminals of the switch (normally open). When the switch is closed, the input reference signal is tied to the maximum voltage value and consequently the current of the solenoid reaches the maximum value. When the switch is open the current flowing into the solenoid reaches the minimum value. The **ramp up** and **ramp down** potentiometers allow to adjust, using linear ramp, respectively the time delay between the switching from minimum to maximum current and the delay between the switching from maximum to minimum current. The minimum and maximum current values are adjusted with the offset and full load potentiometers.

2 - Control mode using a voltage generator as input signal.

The external signal control must be connected to terminal 3 and ground (0V) must be connected to terminal 2. The input voltage on the terminal 3 can be regulated from 0 to 10V. The current on the valve coil is proportional to the

input command voltage. Set this signal to the maximum value(10V), then proceed to the adjustment of the full load potentiometer, in order to set the maximum current value on the solenoid.

3 - Control mode with potentiometer.

Pins 1, 2 and 3 of the potentiometer must be connected respectively to the **GND**, **3** and **2** terminals of the controller. To setup the controller, rotate the potentiometer fully clockwise and follow the **“Adjustment instructions”**. A 5KOhm potentiometer is recommended. In any case the potentiometer value must be between 2KOhm and 5KOhm.

4 - Two axes control with joystick.

This control can be done using a joystick with two axes and two EPC-H02 devices. The joystick is connected to a voltage converter; this converters supplies the input reference signals for the two devices. The currents and the ramps of the two devices are independent. By doubling the above said system, it is possible to realize a four axes system.

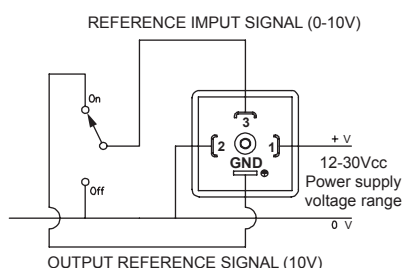

(ON-OFF CONNECTION)

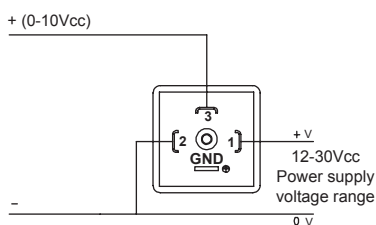

(EXTERNAL CONNECTION)

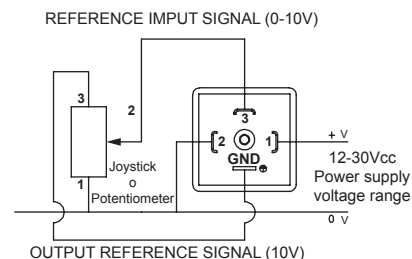

(POTENTIOMETER CONNECTION)

ADJUSTMENT INSTRUCTIONS

After the system is connected, verify that is possible to move the hydraulic cylinder using the potentiometer or the switch. Set the ramp up and ramp down potentiometers to zero, rotating the cursor completely counter clockwise. Set the external potentiometer to zero (or open the external switch) and set the minimum current of the solenoid using the offset potentiometer, rotating it until the hydraulic device begins to move: with this setting, the system will operate without delay. Set the full load potentiometer to zero and rotate the external control potentiometer

completely clockwise (or close the external switch): rotate the full load potentiometer clockwise until the hydraulic cylinder reaches the maximum displacement, then rotate the full load potentiometer back until the hydraulic cylinder comes back slightly. Once the tuning of the start and end positions of the hydraulic cylinder stroke is complete, it is possible to regulate the switching speed between the two extreme positions of the stroke using the ramp up and ramp down potentiometers. This further adjustment doesn't affect the previously tuned settings.