

Working pressure 700 Bar

Choice of air or electric power options

Supplied complete with hand pendant controller

Hi-Force hydraulic torque wrench pumps are compatible for use with all Hi-Force hydraulic torque wrenches. All models are 700 Bar maximum working pressure, fitted with an easily accessible and adjustable torque setting pressure relief valve, and are available as air driven or electric driven pump units. All pumps are supplied with a remote operation, push button hand pendant controller with three metres of control line cable. Glycerine filled, easy to read, dual scale (0-700 Bar/0-10,000 PSI) hydraulic pressure gauges are fitted as standard to all models. Air driven versions also include an integral inline filter, regulator, lubricator system with airline pressure gauge and an exhaust air cooling system.

F

- >> Dual scale glycerine filled pressure gauge fitted as standard
- >> Two speed operation with choice of standard length hoses available
- >> Externally adjustable torque setting pressure relief valve fitted as standard
- >> Protective carrying frame and oil sight level gauge
- >> Air pressure gauge and filter-regulator-lubricator unit (air powered pumps only)
- >> Integral oil cooling system (air powered pumps only)
- >> HTWP2141/2AR are fitted with auto retract function as standard

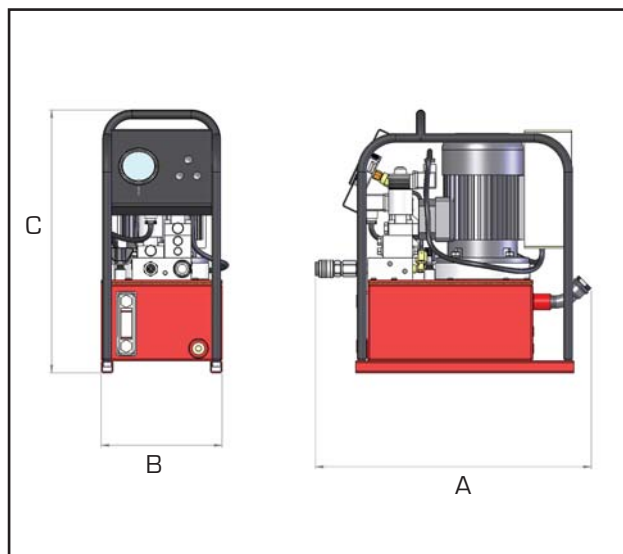

Model number	Max pressure bar	Power supply	Motor rating kW	Displacement l/min low pressure	Displacement l/min high pressure	Changeover pressure bar	Weight kg
HTWP2140P	700	7 Bar	1.50	6.1	0.51	60	28.0
HTWP2141AR	700	110 volt	0.75	3.9	0.36	60	34.0
HTWP2142AR	700	240 volt	0.75	3.9	0.36	60	34.0
HTWP3140P-A	700	7 Bar	3.70	13.5	1.90	100	60.0
HTWP3141P-A	700	110 volt	2.20	6.3	0.90	100	72.0
HTWP3142P-A	700	240 volt	2.20	6.3	0.90	100	72.0

Dimensions in mm		
A	B	C
468	205	445
468	205	445
468	205	445
547	246	589
547	246	653
547	246	653