

Centrale elettronica
Electronic control unit
Centrale électronique
Elektronische Steuereinheit
Central electrónica
Central electrónica
Elektroniczna jednostka sterująca
Electrische zekering

900CT-824S

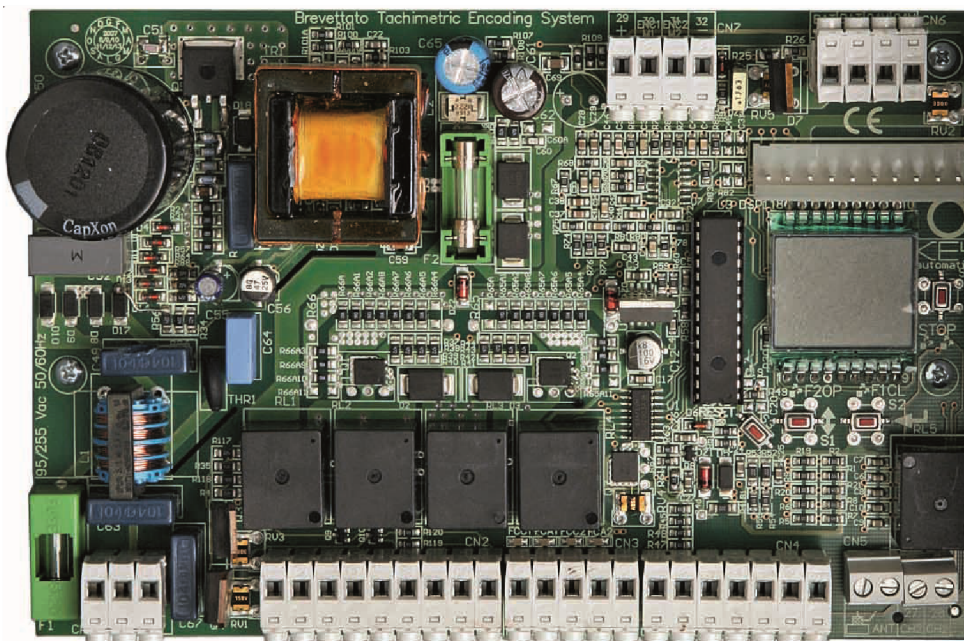

IT MANUALE ISTRUZIONI
GB INSTRUCTION MANUAL
F MANUEL D'EMPLOI
D BEDIENUNGSANLEITUNG
E MANUAL DE INSTRUCCIONES
P MANUAL DE INSTRUÇÕES
PL INSTRUKCJA OBSŁUGI
NL GEBRUIKSHANDLEIDING

www.DigiDsc.com

• 2144757973
• 2144929013
• 2144748478
• 9123036082



Key Automation S.p.A



Organizzazione con Sistema
di Gestione certificato
Company with Management
System certified

ISO 9001:2008

SINCERT

⚠ WARNING: 

*It is advisable to read the instructions carefully before you start installation.
Failure to comply with these instructions, improper use or incorrect connection may compromise the safety or correct operation of the device and hence of the entire system.*

No liability shall be accepted for any malfunctions and/or damage due to failure to comply with the instructions.

The company reserves the right to make improvements to the products.

⚠ WARNING:

This appliance is not intended to be used by persons (including children) whose physical, sensory or mental are reduced, or lack of experience or knowledge, unless they have been able to benefit, through the intermediary of a person responsible for their security, surveillance or statements regarding your use of the appliance.

-Children must be supervised to ensure that do not play with the appliance;

-Do not allow children to play with the controls.

⚠ THIS BOOKLET IS TO BE USED ONLY BY THE INSTALLER

Installation must be carried out only by professionally qualified personnel in compliance with current legal requirements.

All connection must be performed without mains supply.

 ELECTRICAL CONNECTIONS

To ensure operator safety and to prevent damage to the components while connections are being made, or when the radio card is being inserted, the control unit absolutely must not be powered on. For power cords, motor lines, flasher/courtesy light line, and electric lock, use a cable with a cross-section that is suitable for the length (minimum 1.5 mm²).

For auxiliary power supplies, controls and safety contacts a minimum section of 0,5 mm². When the control cables are very long (more than 30 m), de-coupling is suggested using relays at the control unit.

If a fuse trips, after removing the cause, replace it with another one of the same type. Install the various safety devices, limit switches, photocells, sensitive rib, stop button.

If one or more of the safety devices are not installed, the corresponding terminals must be short circuited with the controls common.

All contacts N.C. Assigned to the same input must be connected in series.

All contacts N.O. Assigned to the same input must be connected in parallel.

Provide disconnecting devices in the power supply network in accessible places.

For the power supply of the control unit, there must be an external disconnecting switch (not included), independent and properly sized.

Before to activation of the engine we asks:

- Unlock the engine mechanically and verify the exact link of the limit switch according to the opening and closing of the door, the led corresponding to the position switches concerned must GO OFF with limit switches activated
- manually close the door, make now a boost of P/P by pressing the corresponding button; the first manoeuvre required to effect the APERTURE is one, if not remove power to the facility and turn the connector to reverse the opens with the closes.

⚠ WARNING 

The data and information contained in this manual are subject to change at any time and without prior notice from Key Automation S.p.A.

MODELS AND CHARACTERISTICS

900CT-824S

Control unit for two motors, 24 Vdc with encoder and switching power supply, tachymetric and amperometric electronic clutch, set up for radio card and integrated battery charger module, supplied with plastic box

ENGLISH

TECHNICAL DATA	900CT-824S
POWER SUPPLY	95-255 Vac 50/60 Hz
ACCESSORY POWER SUPPLY OUTPUT	24 Vdc 400 mA
WORKING TIME	0-120 sec
PAUSE TIME	0-120 sec
OPERATING TEMPERATURE	-20°C/+70°C

CONNECTIONS

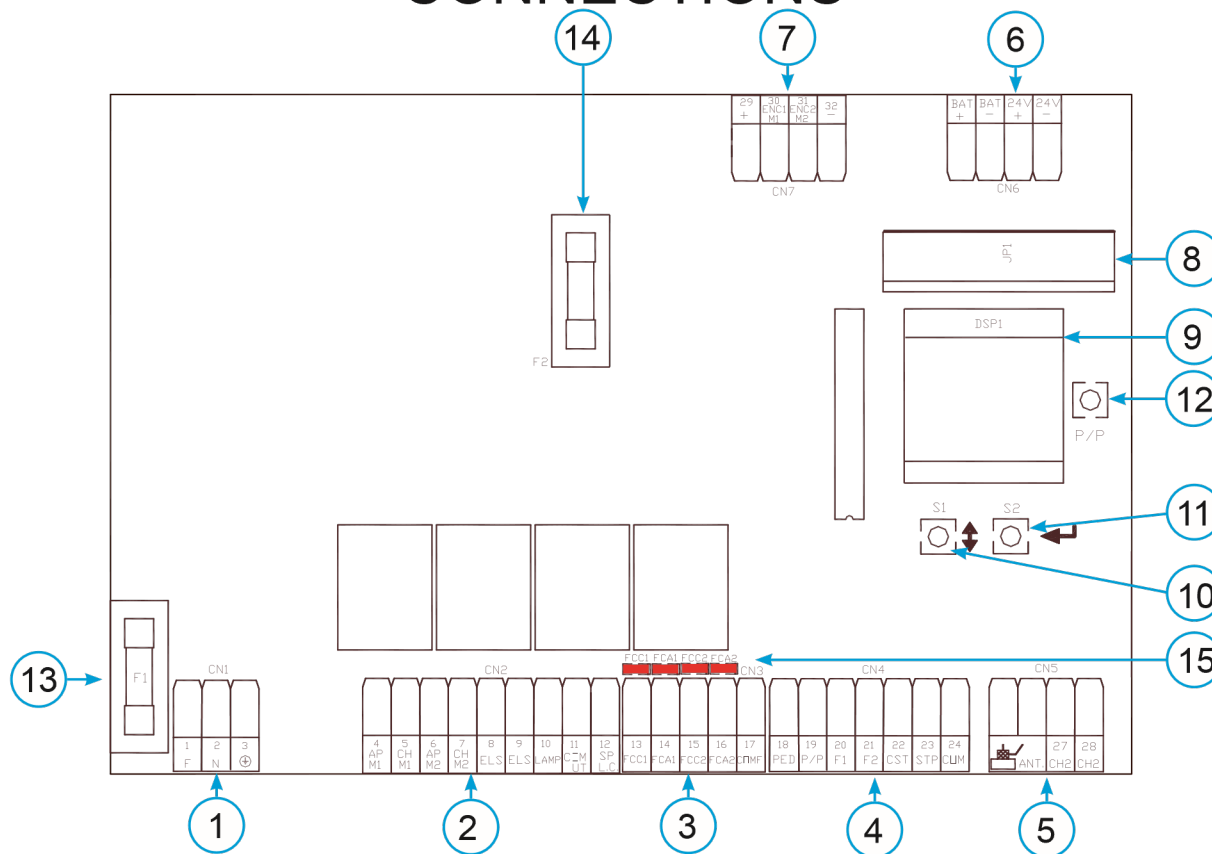

DESCRIPTION

- ① CN1 Power supply 95-255 Vac
- ② CN2 Supply engines and accessory
- ③ CN3 Connection safeties
- ④ CN4 Connection exit (Controls and safeties)
- ⑤ CN5 Connection antenna and second radio channel
- ⑥ CN6 Connection batteries and accessory supplies 24Vdc
- ⑦ CN7 Connection encoder
- ⑧ JP1 Connector for radio receiver
- ⑨ DSP1 Display for signalling functions and safety inputs
- ⑩ S1 Button for scrolling programming functions (see table)
- ⑪ S2 Button for selecting programming functions
- ⑫ P/P Step/step button
- ⑬ F1 Line protection 230Vac 1,6A
- ⑭ F2 Engine line protection 230Vac 8A
- ⑮ Signaling led of safeties Led on = contact closed

CONNECTOR CN1

- 1) F Phase 95-255 Vac
- 2) N Neutral 95-255 Vac
- 3)  Ground

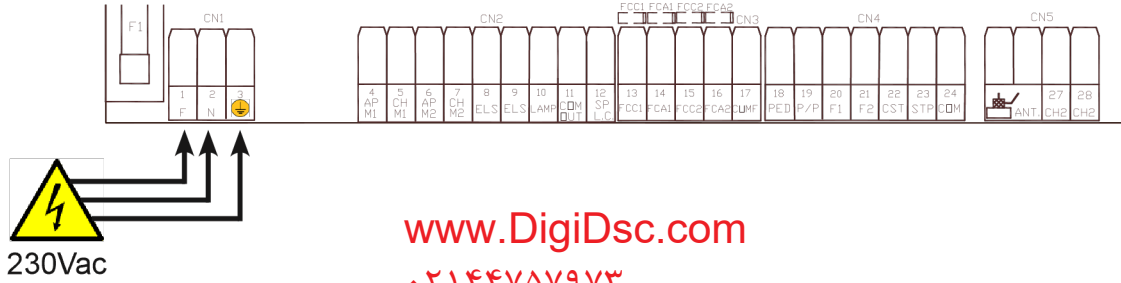

www.DigiDsc.com

- 2144757973
- 2144929.13
- 2144748478
- 9123.36.82

CONNECTOR CN2

- 4) AP M1 M1 motor connection
- 5) CH M1 M1 motor connection
- 6) AP M2 M2 motor connection
- 7) CH M2 M2 motor connection
- 8) ELS Electric lock output connection
- 9) ELS Electric lock output connection

Motor M2 starts first during closing

- 10) LAMP Flasher connection max. 25W 24Vdc
- 11) COM OUT Common link Blinking light gate open/courtesy light
- 12) SP LC Gate open indicator / courtesy light max 3Watt 24Vdc

for higher power levels, it is recommended to connected a relay sized for the applied load to this output

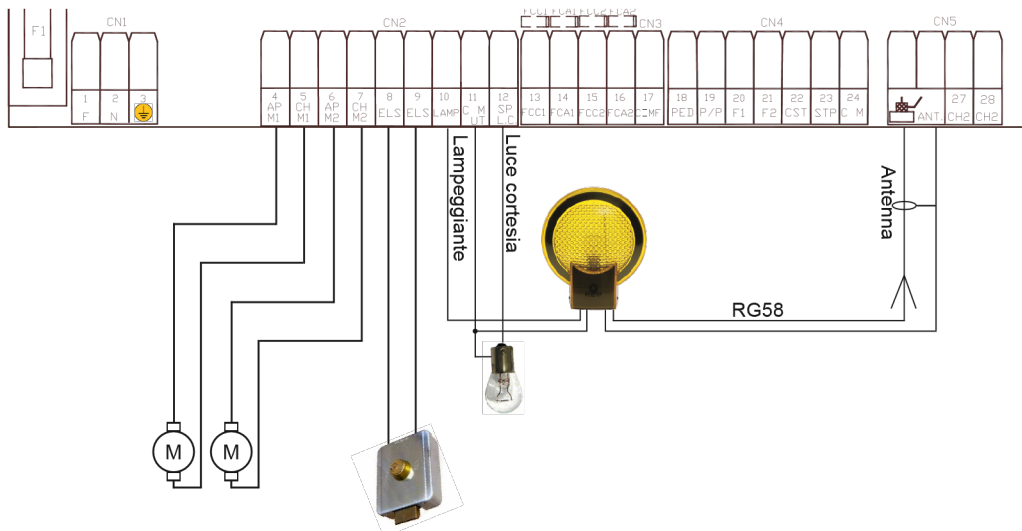

CONNECTOR CN3

- 13) FCC1 Motor 1 limit switch (closing limit switch)
- 14) FCA1 Motor 1 limit switch (opening limit switch)
- 15) FCC2 Motor 2 limit switch (closing limit switch)
- 16) FCA2 Motor 2 limit switch (opening limit switch)
- 17) COMF Motors 1-2 limit switch common connection

www.DigiDsc.com

• 2144757973

• 2144929.13

• 2144748478

N.B. the LEDs corresponding to the limit switches are ON when the relative limit switch is not involved, if the limit switches are not used, they MUST be JUMPED on the COMF terminal

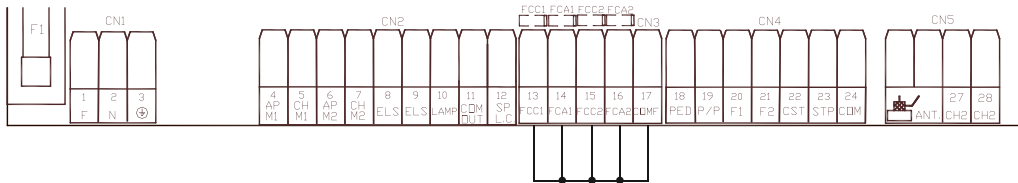

CONNECTOR CN4

- 18) PED Connection of the Pedestrian Function N.O. contact Normally Open
With 2 motor operation, door M1 is opened completely, in the case of a pedestrian opening and at the same time, with a step/step P/P impulse, door 2 starts immediately if 2 motors are selected, it opens fully if 1 motor is selected.
- 19) P/P Connection of the Step/Step Function N.O. contact Normally Open
Input of the Open/Close or Open/Stop/Close command based on the selection of Parameter D
- 20) F1 Connection of the Close Photocell F1 N.C. contact Normally Closed
This input is considered a safety, the contact can be interrupted at any time during closing of the automation causing an immediate stop in movement and reversing the direction of movement
- 21) F2 Connection of the Open Photocell F2 N.C. contact Normally Closed
This input is considered a safety, the contact can be interrupted at any time during opening by the automation causing an immediate stop in movement, the automation will continue until the contact is restored.
- 22) CST Rib connection Normally Closed contact N.C.
At each intervention of the photo-rib, the motion will stop and invert for 2 seconds, and will then stop, deactivating the automatic closure if activated
- 23) STP Stop connection Normally Closed contact N.C.
This input is considered a safety. The contact may be interrupted at any moment immediately stopping the automation disabling any function including automatic closing
- 24) COM Link common commands and of securities

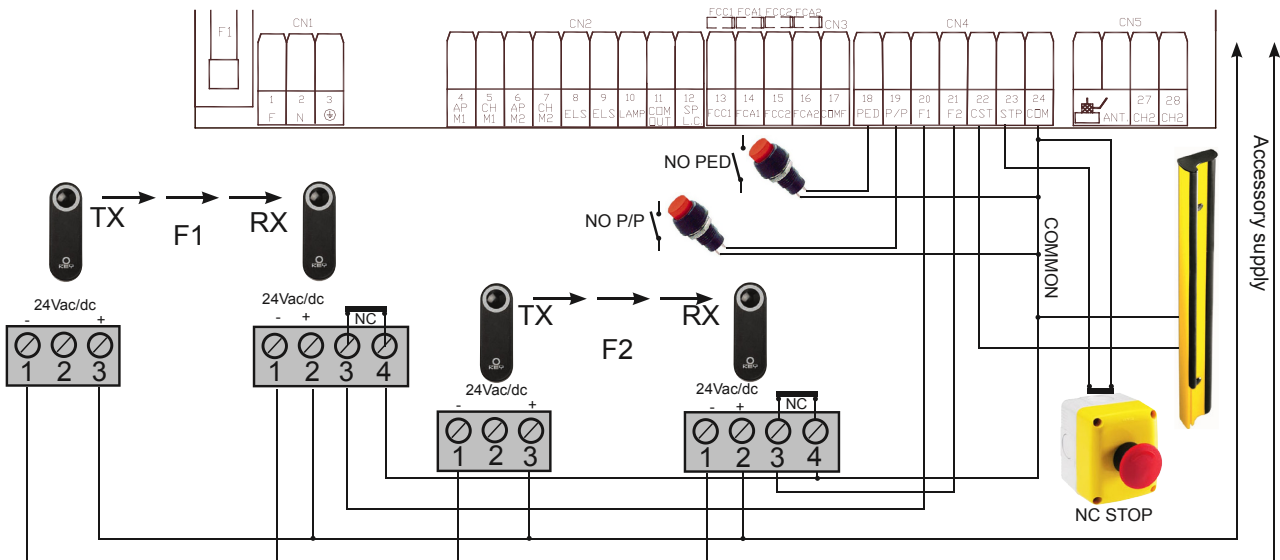

ENGLISH

CONNECTOR CN5

- 25) ANT Antenna connection (signal)
- 26) ANT Antenna connection (braid)
- 27) CH2 2nd radio channel connection (only if the 2 channel snap-in receiver is used)
- 28) CH2 2nd radio channel connection (only if the 2 channel snap-in receiver is used)

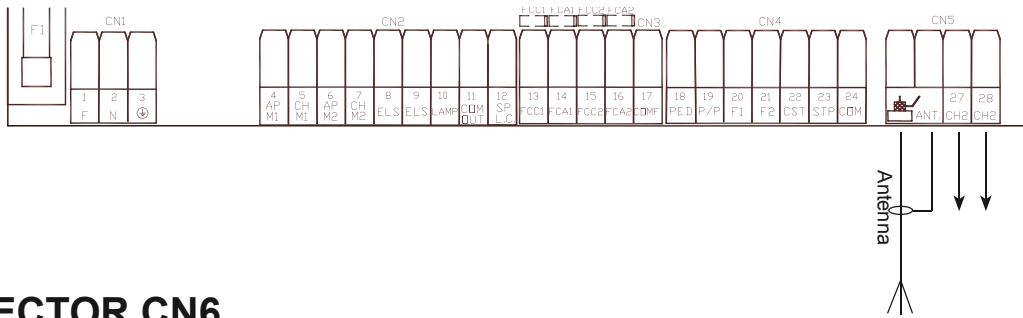

CONNECTOR CN6

- 33) BAT+ Connection positive battery charger
- 34) BAT- Connection negative battery charger

Built-in current controlled recharge circuit with backup operation, electronically protected against short circuits for use it connect 2 batteries in series 12Vdc max.7Ah

- 35) 24V+ Connection of accessory power supply 24Vac 300mA max
- 36) 24V- Connection of accessory power supply 24Vac 300mA max

CONNECTOR CN7

- 29) + Positive power supply of the encoders
- 30) ENC1 M1 Signal of the encoder for motor M1
- 31) ENC2 M2 Signal of the encoder for motor M2
- 32) - Negative power supply of the encoders

The electronic brake is always active in both operating directions, when it intervenes the operation reverses for both doors for 2 seconds then the movement is stopped for 1 second then it continues motion in the direction opposite of the obstacle; if it intervenes three consecutive times, the entire system will STOP, deactivating the automatic closure if necessary, making it necessary for the user to provide a start impulse, upon which the control unit will perform a realignment when opening, showing EM on the display.

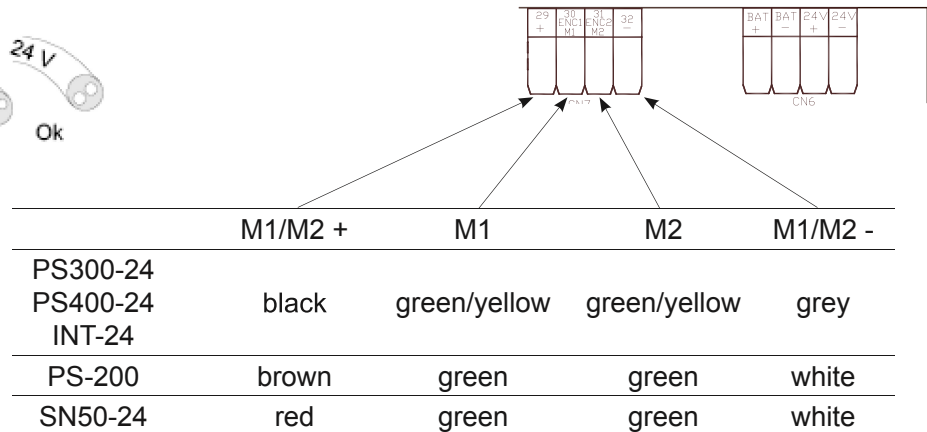
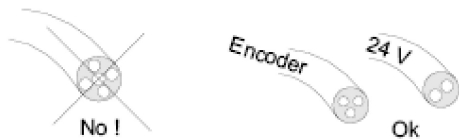

CONNECTOR JP1

Connector for radio receiver mod:
900RXI-42, 900RXI-42R, 900RXI-22

VISUAL DIAGNOSIS

Visual diagnosis of correct connection of controls:

The control unit is designed to permit installation as quickly as possible, and thus to see immediately whether the wiring connections are correct by means of LED indicators:

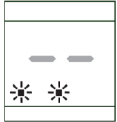

- STOP input no. 23 in which the use of a N.C. contact is mandatory must be closed and the two LCD dots must NOT flash. If they flash this means that the contact is open

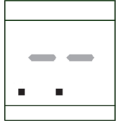

- The RIB input no. 22 in which the use of a N.C. contact is mandatory must be closed and the two LCD dots must NOT turn on steady, if they are ON STEADY this means that the contact is open

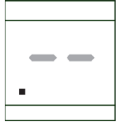

- The PHOTO OPEN F2 input no. 21 in which the use of a N.C. contact is mandatory must be closed and the F2OP left LCD dot must be OFF, if it ON STEADY this means that the contact is open

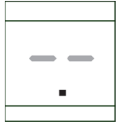

- The PHOTO CLOSE F1 input no. 20 in which the use of a N.C. contact is mandatory must be closed and the F1CL right LCD dot must be OFF, if it ON STEADY this means that the contact is open

N.B. In normal conditions of use, the LCD dots must not flash or be on steady, they turn on or flash if the corresponding safety is tripped

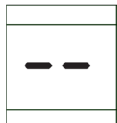

- With the automation closed, will be shown

www.DigiDsc.com

• 2144757973

• 2144929.13



- During OPENING the display will show OP

• 2144748478

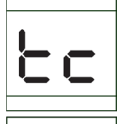

- If you have selected Automatic operation, TC will be shown in the pause time



- During CLOSING the display will show CL

• By using a new P/P command check that the complete opening of the door is carried out up to the stop. At this point press the P/P button again and check the complete closing of the door up to the stop.

• After having verified the correct complete opening and closing enable the deceleration based on the desired percentage (Par. H) and the maximum motor force (Par. A)



- The electronic brake is always active in both operating directions, when it intervenes the operation reverses for both doors for 2 sec., then the movement is stopped for 1 sec. then it continues motion in the direction opposite of the obstacle; if it intervenes three consecutive times, the entire system will STOP, deactivating the automatic closure if necessary, making it necessary for the user to provide a start impulse, upon which the control unit will perform a realignment when opening, showing EM on the display.



PROGRAMMING

The following procedure is used to access the self-learning procedure for working times/automatic closure/door offset:

1. Position the doors to half their opening position,
2. Press down on the S2 ENTER button until Parameter A is displayed
3. Press the P/P button, door 2 will start to close and after 3 sec. door 1 will start to close (if the first movement is not closure, press the reset button and invert the motor connection wires)
4. After both doors have closed completely, door 1 will open automatically and after 2 sec. door 2 will open (the entire procedure is performed in slow motion)
5. After both doors have completely opened the count for the automatic closure time will start, which is displayed in sec. on the display, after the desired time has passed perform a P/P command, the M2 door will close first, then pressing the P/P command again will cause the M1 door to close in order to self-learn the desired door delay time N.B. If you want to have the door delay time equal to 0, simply press the P/P button two times after learning the automatic closure time.
6. Once both doors have closed completely, the programming procedure will end automatically

N.B.: Depending on the maximum opening stop point, in normal operation the control unit will automatically stop the doors in advance to prevent striking the mechanical stop (remember that the mechanical stop is obligatory)

N.B.:Once the parameters have been displayed, the total manoeuvres counter are shown in two different screens, where the thousand units are indicated by the lighting up of the point. To reset this counter, simultaneously press and hold buttons P1 and P2 (ENTER/UP-DOWN) until 0000 is displayed

N.B. If the point of the LCD on the left lights up, it means that 10,000 manoeuvres have been exceeded, which must be added to the value shown.

To exit parameter display, press ENTER several times until automatic closure condition is shown (- - two dashes).

www.DigiDsc.com

• 2144757973

• 2144929.13

• 2144748478

• 9123.36.82

FUNCTIONS \ VALUES		0	1	2	3	4	5	9
A	ELECTRONIC CLUTCH (sensitivity)	--	Maximum	Average maximum	Average minimum	mini- mum	Sensitivity selection parameter: Maximum sensitivity= minimum force	
b	MOTOR SPEED	--	Minimum	Maximum	Motor speed selection parameter			
c	AUTOMATIC CLOSURE (seconds)	NO	YES	pedes- trian only	Automatic closure selection parameter			
d	OPEN COMMAND	Open Stop Close	Open Close	Activating the P/P function prevents the automation from stop- ping; remember that this enabled function may be critical for automations with great inertia				
E	CONDOMINIUM (OPENING ONLY)	NO	YES	Activating the condominium function, the first P/P impulse opens and only accepts reopening while the door is closing				
F	ELECTRIC LOCK BATTERING RAM	NO	YES (only when opening)	YES (when opening / closing)	Selecting the Battering ram parameter, the control unit will permit the releasing and coupling of the electric lock, commanding the closing motors for a brief period of time			
G	SP/LC OUTPUT	Indicator on	Courtesy light	Selection parameter for output as an open gate indicator or courtesy light Parameter G=0 enables the gate open indicator where the flasher frequency indicates the automation status : <ul style="list-style-type: none"> slow while opening quick while closing on steady when the gate has stopped open it turns off with the gate closed Parameter G=1 enables the courtesy light timed for 90 sec. from the first opening or closing impulse				
H	% SLOW MOTION	NO	10%	20%	30%	40%	% of travel in slow motion selection parameter	
I	SLOW MOTION SPEED	--	low	Medium low	Medium high	High	Speed during slow motion selection parameter	
L	LIMIT SWITCH	NO	YES	Motors with electric limit switch selection parameter (SN50-24)				
n	No. OF MOTORS	--	1	2	1 or 2 motor automation selection parameter			
o	PRE-FLASH	NO	1 sec	2 sec.	3 sec.	8 sec.	Activating the Pre-flash func- tion, the flasher is activated for the selected period of time before each closing movement	
O	CLOSE AFTER TRANSIT	NO	YES	Activating the Close after Transit function, with automatic closure activated, permits the closure of the automation in the shortest period of time without waiting for the automatic reclosure				
P	TIMER / MAGNETIC LOOP (to be connected on P/P)	NO	YES	When you activate the function Timer / Magnetic Coil via parameter P after terminating total opening if step/step contact is kept closed the automatic closing time is locked so that the gate never closes until the step/step contact is opened again, if there are several step/step impulses during the standby time for automatic closing the time will be continuously reset				
r	SOFT START	NO	YES	Activating the Soft Start function, during the first seconds of movement of the automation, the control unit will command the motor to operate at a reduced speed for a softer start				
S	SOFT STOP	NO	YES	Activating the Soft Stop function, during the last seconds of movement of the automation, the control unit will command the motor to operate at a reduced speed for a softer arrival				
y	PHOTOCELL F2 OPERATION	active only when opening	active when opening and closing	Selection parameter for F2 operation when opening or when opening+closing				
J	MOTOR TYPES	PS-200	PS300- 24/400-24	SN-20	SN50-24	INT-24	Motorisation type selection parameter	
U	COUNTER	NO	4=40000	Activating the function, selecting a value between 1 and 9 (1 value =10000 manoeuvres) it is possible to set a maximum number of ma- noeuvres that as they decrease will signal the request for service with regular luminous flasher signals upon automation closure. To reset the count hold down the S2 enter and S1 up/dwn buttons together for 5 sec.				

N.B.: each function variation is confirmed upon completion of closure

BATTERY KIT

A system with the CT-824S can operate even if there is a mains power outage by installing two 12V 2.2Ah batteries (not supplied) without making any change to the system.

Connection sequence:

- Disconnect the 230Vac power supply
- Connect the two batteries in sequence paying attention to the terminal polarity No.33 BAT+ and No. 34 BAT-
- Check that the safety LED's come on
- Re-connect the mains power supply
- New batteries charge up after about ten hours.

The number of manoeuvres that can be performed with the battery supply depends on many factors; an approximate example could be 4 complete cycles under the following conditions:

- hinged doors 3 mt 250 kg
- system with 1 pair of photocells, snap-in receiver and 1 flasher (20W max.)
- batteries charged
- within 5 hours of 230V power supply failure

FINAL WARNINGS

- The installation of the automation must be performed properly by qualified personnel in possession of legal requirements and in compliance with machine directive.
- Check the solidity of existing structures (columns, hinges, doors) in relation to the force generated by the motor.
- Check that there are suitably sturdy mechanical stops at the end of opening and closing travel of the doors.
- Analyze the risks of the automation and adopt necessary safety measures and warnings.
- install controls (such as the key selector) so that the user is not in a hazardous position.
- Upon completion of installation, check the safety devices several times, as well as those for signalling and automation release.
- Provide the automation with the EC label or tag that contains the danger information and identification data.
- Give the final user the instructions for use, safety warnings and the EC declaration of conformity.
- Make sure the user understands proper automatic, manual and emergency operation of the automation.
- Inform the user in writing (for example in the instructions for use) of any unprotected residual risks and foreseeable improper use.
- Provide a maintenance schedule for the system (at least every 6 months for the safeties) with an appropriate register of work performed.
- Keep this instruction manual for future reference.
- Key Automation S.p.A. reserves the right to make, at any time, any modifications which may be required to improve appearance and/or operation.

DISPOSAL



This product is composed of various components which may in turn contain pollutants. Do not dispose of it in the environment! Find out about the method for recycling or disposing of the product in compliance with current local laws