



### Model Number

**KFU8-DW-1.D**

Overspeed/Underspeed Monitor

### Features

- Speed monitoring up to 40 kHz
- 1 pre-select value with relay output and LED indicator
- 2-, 3-, 4-wire and NAMUR sensors as well as rotary encoder connectable
- Start-up delay
- Menu driven operation via 4 front keys
- Period measurement
- Output signal can be inverted
- Display devices can be set between 0.1 ... 2.5 sec.

### Technical data

#### Functional safety related parameters

MTTF<sub>d</sub> 100 a

#### Supply

Rated voltage 196 ... 250 V AC ; 98 ... 127 V AC; 47 ... 63 Hz  
20.4 ... 28 V DC

Fusing external fusing 4 A

Power consumption AC: < 5 VA  
DC: < 5 W

#### Indicators/operating means

Type 4-digit, 7-segment red display, 7 mm digit height

Display interval 0.002 ... 9999 Hz or  
0.01 ... 9999 min<sup>-1</sup>

Parameter assignment keypad-driven menu

Switching state LED yellow, 3 mm

#### Input 1

Connection terminals 8-, 9+

Connectable sensor types NAMUR sensors according to DIN EN 60947-5-6

Open loop voltage 8.2 V DC

Short-circuit current 6.5 mA

Switching point 1.2 ... 2.1 mA Switching hysteresis approx. 0.2 mA

Input frequency 0.002 ... 10000 Hz, pulse length/duration: ≥ 20μs

Impedance 1.2 kΩ

#### Input 2

Switching point high: 16 ... 30 V DC; max. 10 mA due to integrated constant current sink; R<sub>i</sub> ≈ 3 kΩ  
low: 0 ... 6 V DC

Input frequency 0.002 ... 40000 Hz, pulse length/duration: ≥ 12μs

Connection terminals 7+, 13- sensor supply  
terminals 14, 15 NPN/PNP input (galvanically isolated)

Connectable sensor types Two, three, or four-wire proximity switch, incremental rotary encoder, or externally generated pulses 16 ... 30 V

Sensor supply 19 ... 28 V DC non-stabilised; ≤ 30 mA short-circuit protected

#### Input 3

Start-up override Triggering by external signal 16 ... 30 V or Place jumper between terminals 2/3 or by switching on supply voltage (terminal 2 and terminal 3 permanently bridged)

Jumpering time 0.1 ... 999.9 s (External trigger signal)

#### Output

Relay 1 changeover contact  
NO, NC, COM

Sensor supply 24 V DC ± 10 %, 30 mA , short-circuit protected

Contact loading 250 V AC/2 A/ cos φ ≥ 0.7  
40 V DC/2 A

Delay ≤ 20 ms (incl. calculation time)

Mechanical life ≥ 30.000.000 switching cycles

#### Transfer characteristics

Changing interval 5 ms (Internal processing time)

Time delay before availability ≤ 400 ms

Measuring error 0 ... 40000 Hz: ≤ ±0,10%  
Display: ±1 digit

Timer function ON-delay, OFF-delay, one shot, pulse extension

Time 0 ... 999.9 s ; Direction of action reversible

#### Standard conformity

Electromagnetic compatibility acc. to EN 50081-2 / EN 50082-2

#### Ambient conditions

Ambient temperature -25 ... 50 °C (-13 ... 122 °F)

Storage temperature -40 ... 85 °C (-40 ... 185 °F)

Relative humidity max. 80 %, not condensing

Altitude 0 ... 2000 m

Operating conditions The device has only to be used in an indoor area.

#### Mechanical specifications

Protection degree IP20

Connection coded, removable terminals , max. core cross-section 0.34 ... 2.5 mm<sup>2</sup>

Construction type modular terminal housing in Makrolon, System KF

Mounting Snap onto 35 mm standard rail compliant with DIN EN 50022 or Screw fastening using slide-on straps in a 90 mm net

Dimensions

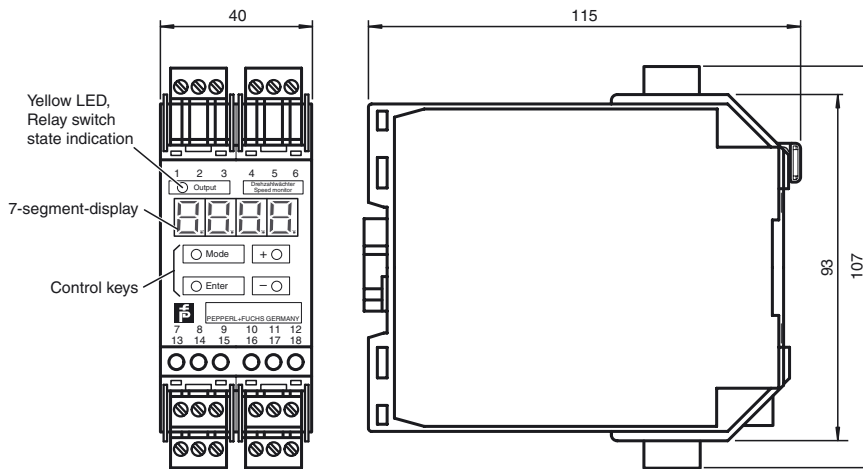

Electrical connection

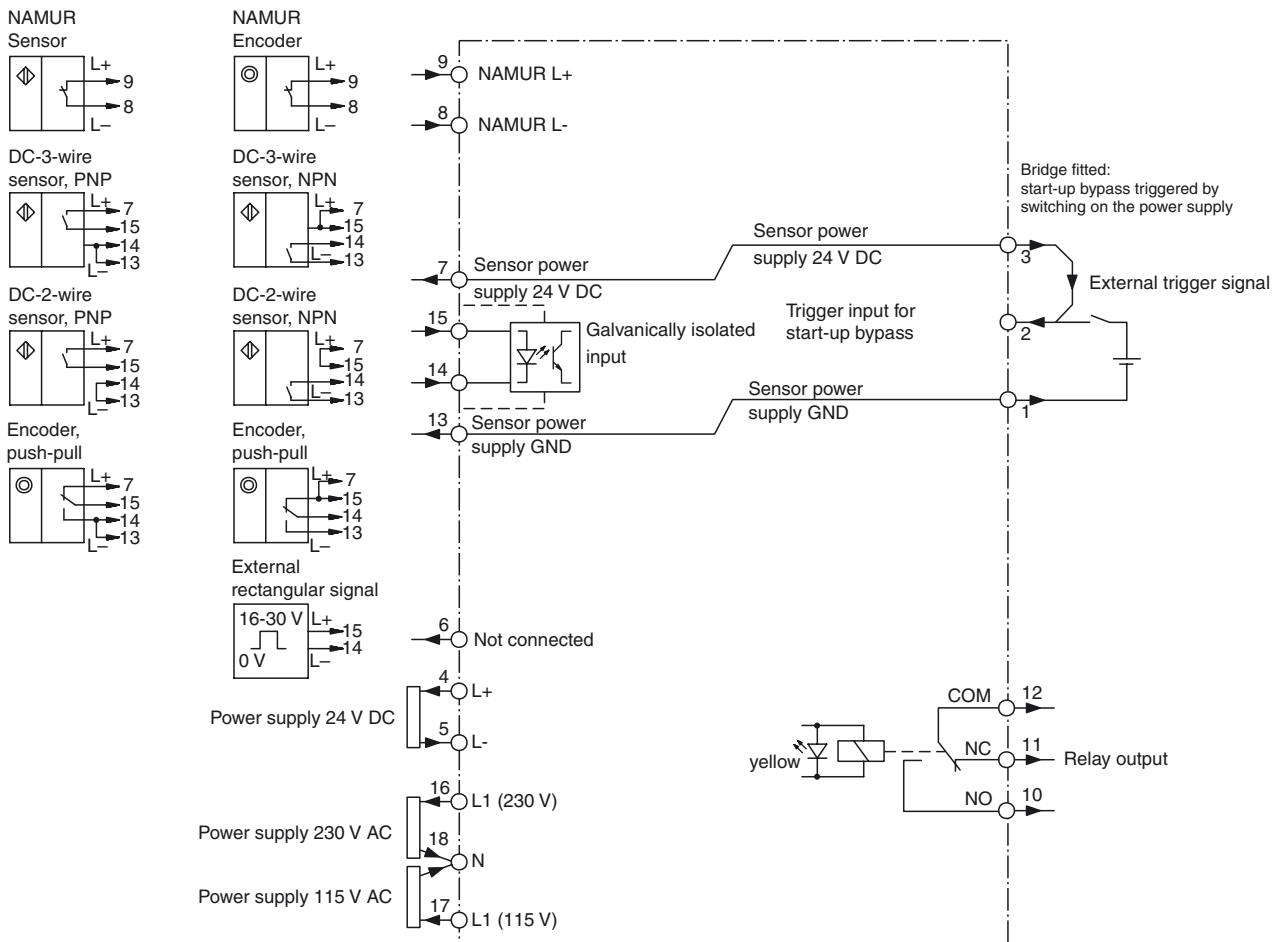

Notes

## Device description

The KFU8-DW-1.D Speed Monitor is a device for the **indication and monitoring of periodic signals**, which occur in almost all areas of automation and process technology, i. e. of frequencies in general and rotational speeds in special cases. The input signals are evaluated in accordance with the cycle method, i. e. by measurement of the period of oscillation and conversion into frequency or rotational speed by a very fast  $\mu$  controller.

The frequently occurring special case of rotational speed measurement has been paid particular attention in the development of the device. Thus **indication** and **input** can be either in **Hz** or in **rpm**. It is also possible, in applications involving slow processes, in which the signal sensors **provide many pulses per revolution**, to operate automatically with the **actual rotational speed** of the drive by specifying the number of pulses per revolution.

The indication of the measured value is provided on a **4-digit, 7-segment LED display** on the front of the device, with **up to 3 places after the decimal point**.

The monitoring function is achieved on the basis of a **limit value**, whose upper and lower hysteresis value is freely selectable within the respective display range.

The **output signal** is generated by a relay with a changeover contact, when the hysteresis limits are violated. Thanks to a high switching capability, the relay output can **be used for the direct activation** of an actuating element or **as an input signal for a higher level control system**. Also, the switching status of the relay is indicated by means of a **yellow LED** on the front of the device.

A function block is connected in series with the relay, which **10 provides for various timer functions** and thus obviates the requirement for the subsequent addition of a timer relay. In addition to the **pull-in and drop-out delay, passing make contact and pulse extension**, the **direction of operation of the relay**, i. e. monitoring of speed fluctuation about a nominal value, can also be selected.

The built-in **start-up override**, initiated when the power supply is switched on, or by an external signal, **prevents error signals** during the running up of the monitored system.

The speed monitor can be supplied with **115 V AC, 230 V AC or by a 24 V DC** supply and when connected to an alternating voltage it provides a **24 V DC source to supply the signal sensor**.

All current **two, three and four-wire proximity switches** and incremental **encoders** can be accepted as the signal sensor. In addition, two terminals are reserved for the connection of **proximity switches in accordance with DIN 19234 (NAMUR)**.

## Terminal assignment

|        |                                     |
|--------|-------------------------------------|
| T. 1:  | Signal sensor supply GND            |
| T. 2:  | Trigger input for start-up override |
| T. 3:  | Signal sensor supply +24 V DC       |
| T. 4:  | Power supply + 24 V DC              |
| T. 5:  | Power supply GND                    |
| T. 6:  | Not connected.                      |
| T. 7:  | Signal sensor supply +24 V DC       |
| T. 8:  | NAMUR input L-                      |
| T. 9:  | NAMUR input L+                      |
| T. 10: | Relay make contact, NO              |
| T. 11: | Relay break contact, NC             |
| T. 12: | Relay root, COM                     |
| T. 13: | Signal sensor supply GND            |
| T. 14: | Signal sensor NPN input             |
| T. 15: | Signal sensor PNP input             |
| T. 16: | Power supply L1, 230 V AC           |
| T. 17: | Power supply L1, 115 V AC           |
| T. 18: | Power supply N                      |

Timer functions, reversal of operating direction of the output relay

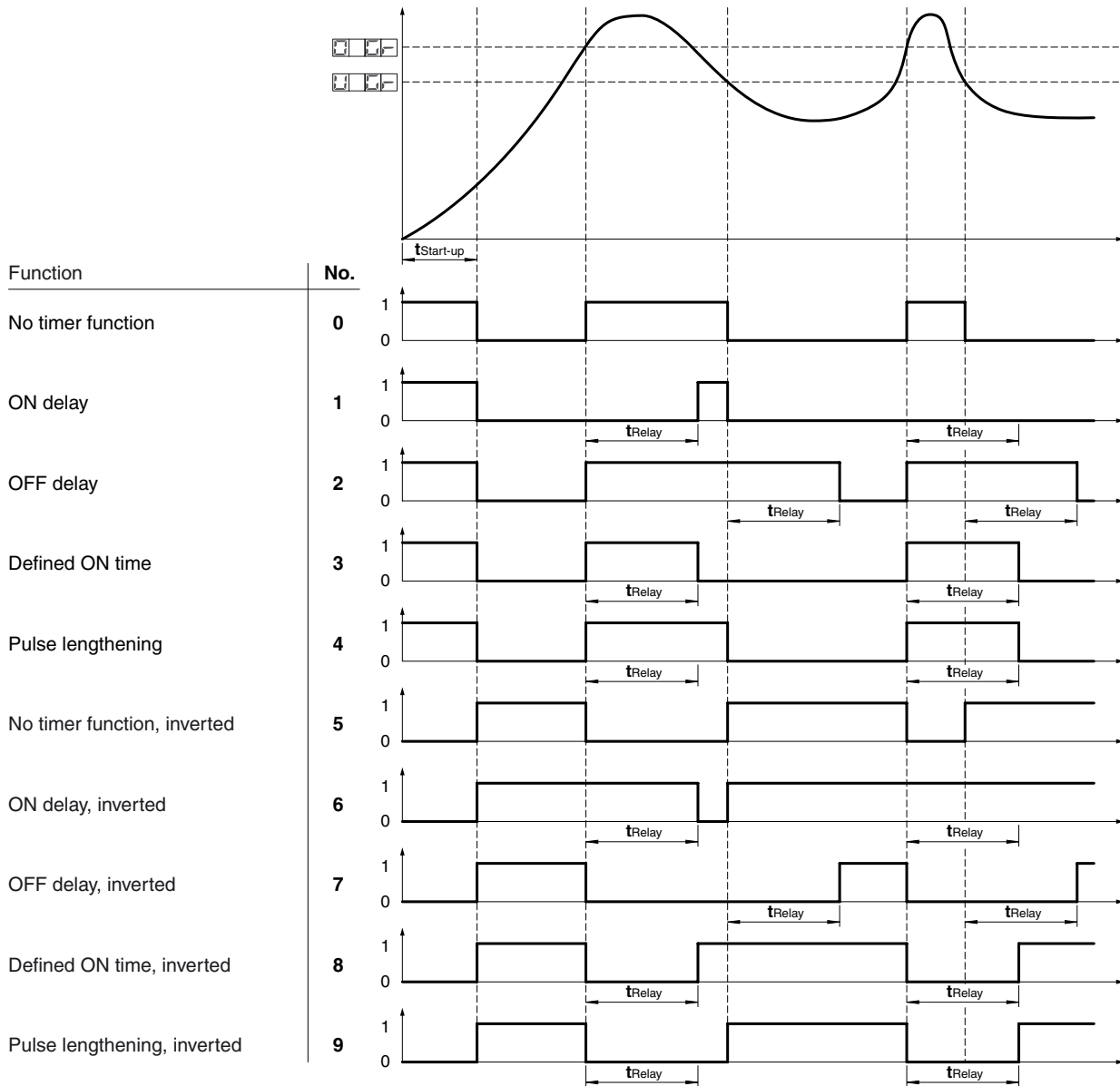

Release date: 2010-12-13 12:08 Date of issue: 2011-01-17 190149\_ENG.xml

Operating principle

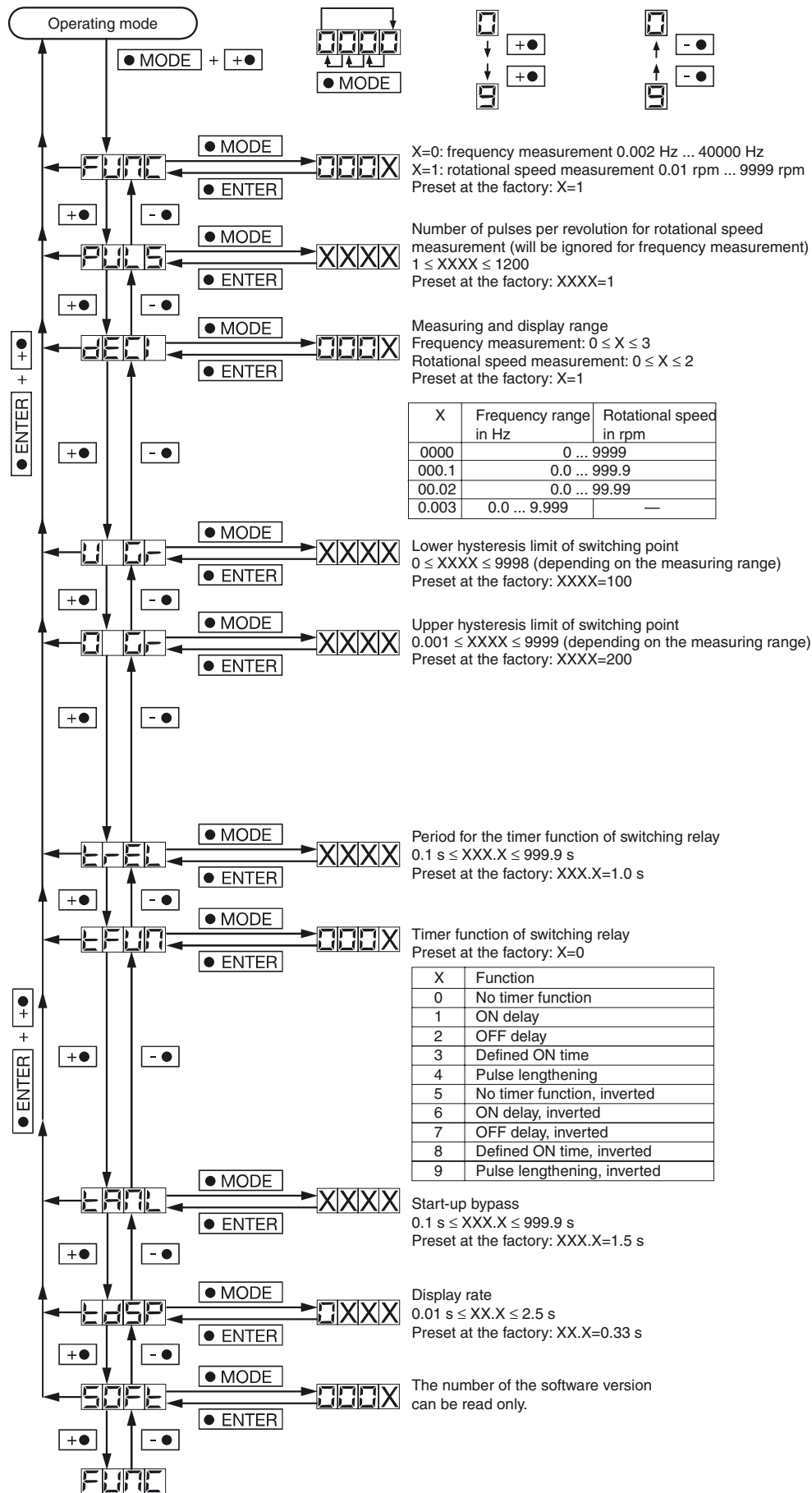

Release date: 2010-12-13 12:08 Date of issue: 2011-01-17 190149\_ENG.xml

Subject to modifications without notice

Pepperl+Fuchs Group  
www.pepperl-fuchs.com

USA: +1 330 486 0001  
fa-info@us.pepperl-fuchs.com

Germany: +49 621 776-4411  
fa-info@pepperl-fuchs.com

Copyright Pepperl+Fuchs  
Singapore: +65 6779 9091  
fa-info@sg.pepperl-fuchs.com