

RSCC

Load cells

Special features

- Load cell with SG measurement system
- Maximum capacities: 50 kg to 5 t
- Hermetically sealed (IP68)
- Rust-resistant materials
- Legal-for-trade to 3000 divisions, test report per OIML-R60 for class III scales
- Meets EMC requirements as per EN 45 501
- Six-wire circuit
- Ex-protection version (optional)



Diagram of RSCC load cell

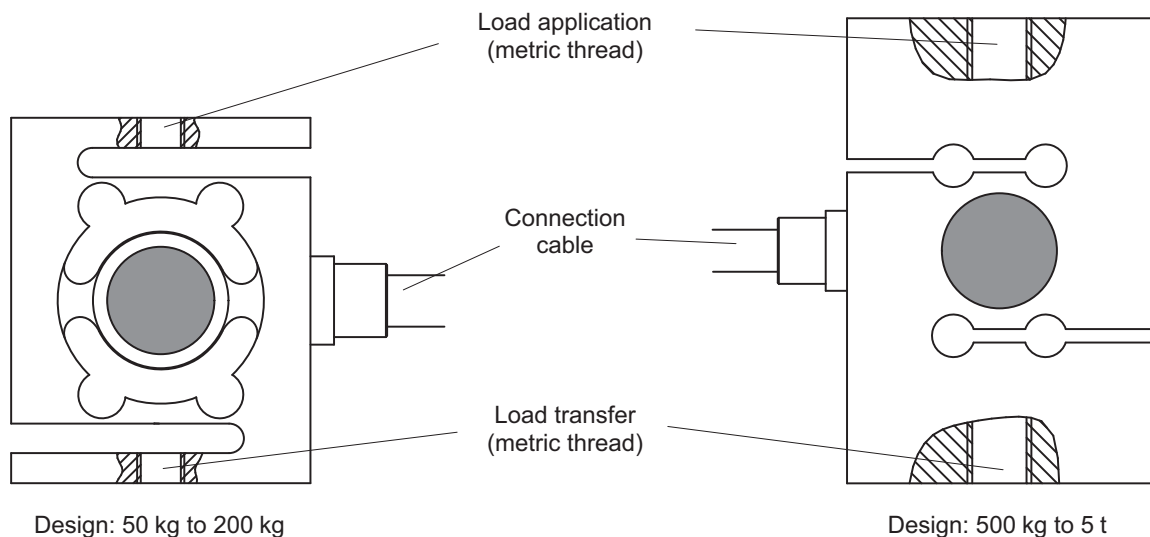

Dimensions (in mm; 1 mm = 0.03937 inches)

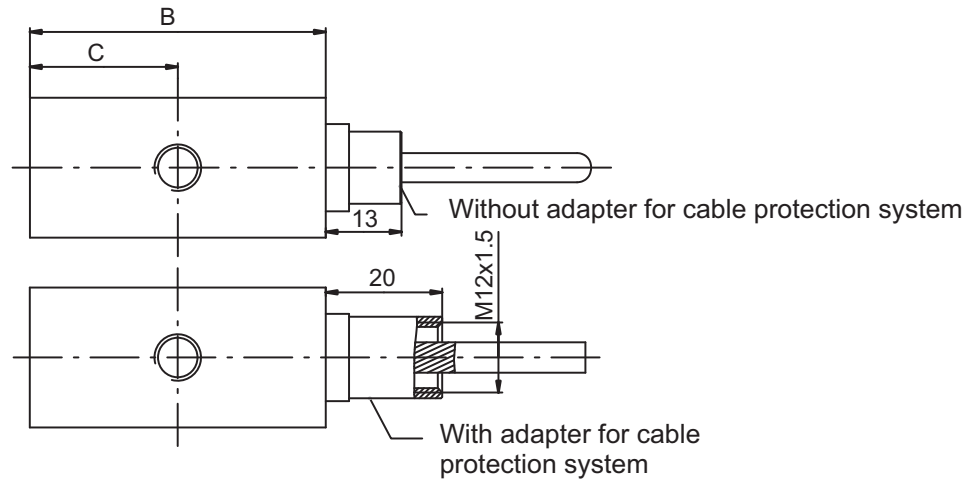
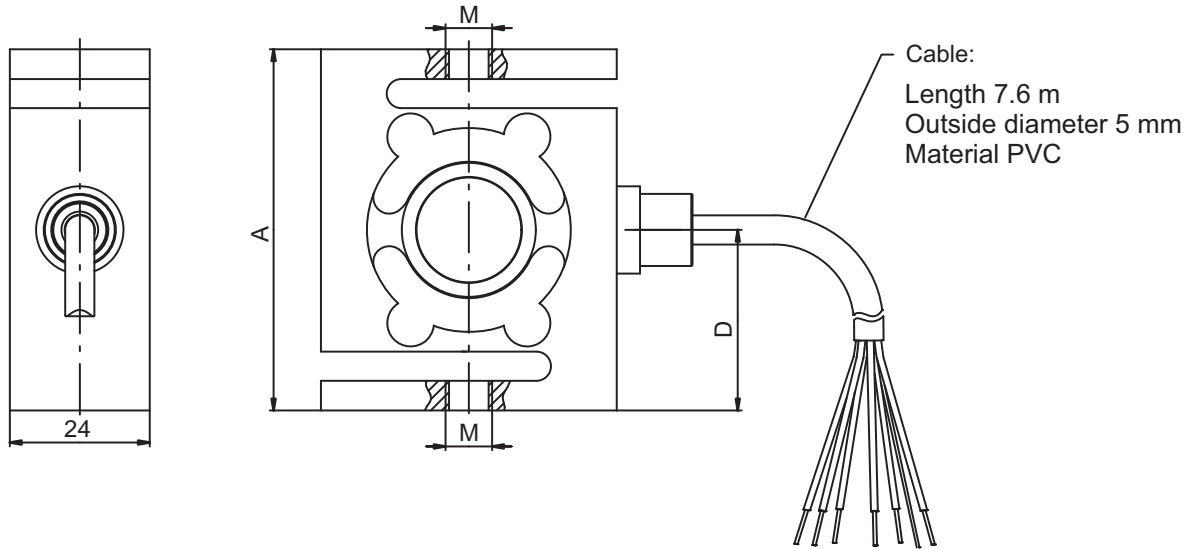

Maximum capacity	A	B	C	D	M
50 kg	62	50.8	25.4	31	M8
100 kg	62	50.8	25.4	31	M8
200 kg	87.3	57.2	28.6	43.7	M12

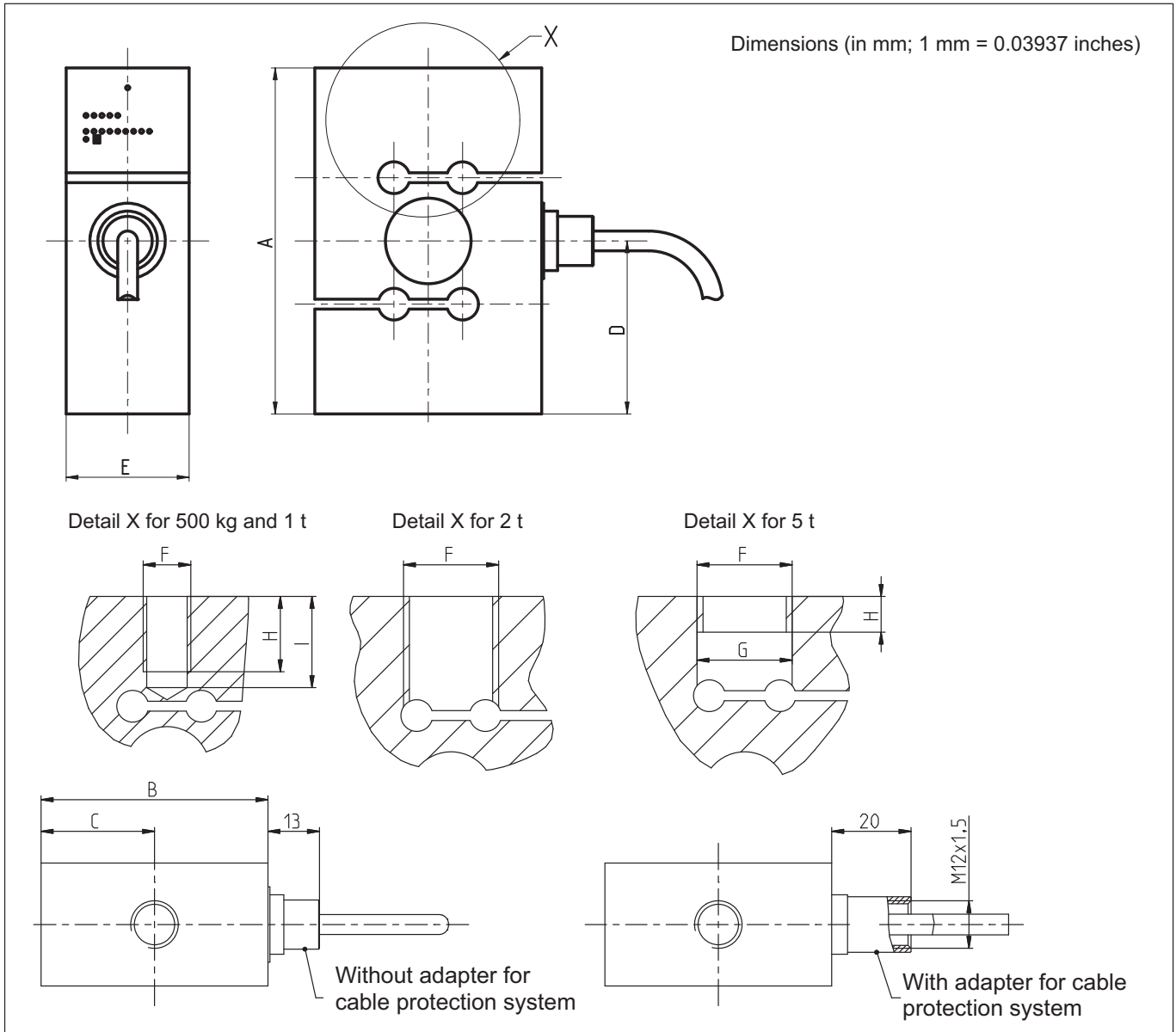

Maximum capacity	A	B	C	D	E	F	G	H	I
500 kg	87.3	57.2	28.6	43.7	31	M12	-	19	23
1 t	87.3	57.3	28.6	43.7	31	M12	-	19	21
2 t	100	69.8	34.9	50	31	M24x2	-	continuous	continuous
5 t	100	76.2	38.1	50	36.5	M24x2	Ø24	9	continuous

Cable protection

(Option 6 required: with adapter for a cable protection system; customer side cable protection version)

Cable protection system*, (provided by customer) comprising:

Screwed cable gland*
Flexible cable protection tubing*
O-ring (provided by customer)

UnscREW the M12 sleeve and replace with an M12 threaded tube coupling

* Supplier such as Flexicon
(<http://www.flexicon.uk.com>)

Mounting accessories (to be ordered separately)

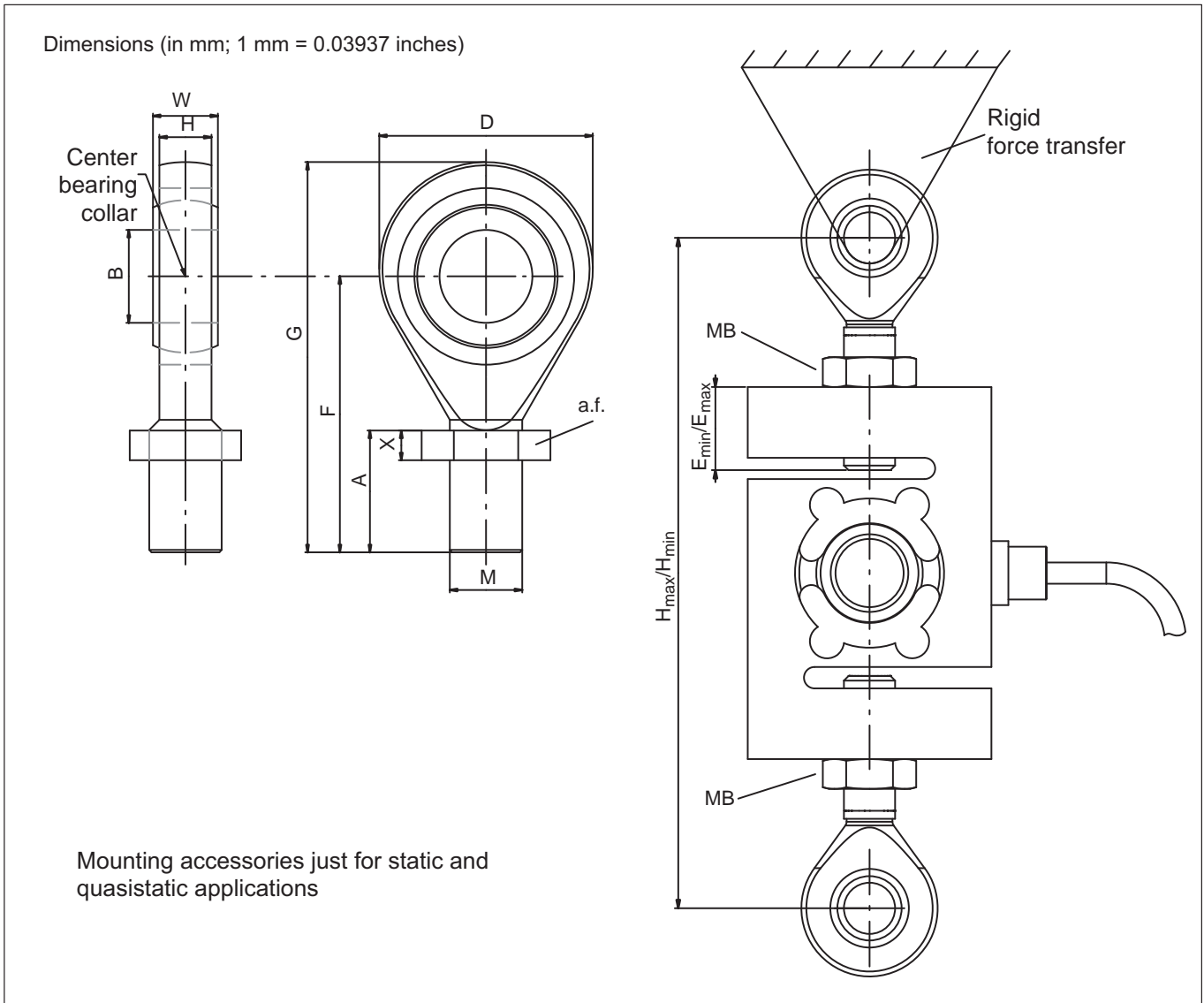

Maximum capacity	Weight (kg)	A	$\varnothing B$ H7	D	F	G	H	M	W	X	a.f.
50 kg to 100 kg	0.05	15	8	24	32	44	9	M8	12	6.5	13
200 kg to 1 t	0.1	33.5	12	32	54.5	70.5	12	M12	16	7	19
2 t to 5 t	0.4	57.5	25	60	94.5	124.5	22	M24x2	31	10	36

Maximum capacity	H_{min}	H_{max}	E_{min}	E_{max}	M_B (N·m)
50 kg	110	118	4	8	15
100 kg	110	118	4	8	15
200 kg	156	174	11	20	50
500 kg	158	174	11	19	50
1 t	158	174	11	19	50
2 t	231	263	13	29	200
5 t	241	265	12	24	500

Specifications

Type		RSCC						
Accuracy class as per OIML R 60		C3						
Number of load cell verification intervals (n_{LC})		3000						
Maximum capacity (E_{max})		50 kg	100 kg	200 kg	500 kg	1 t	2 t	5 t
Minimum load cell verification interval (v_{min})	% of E_{max}	0.0120						
Nominal (rated) sensitivity (C_N)	mV/V	2						
Sensitivity tolerance	%	± 0.25						
Zero signal	mV/V	0 ± 0.1						
Temperature coefficient of sensitivity (TK_C) ¹⁾	% of C_N / 10 K	± 0.0170 (20°C to 40°C) ± 0.0110 (-10°C to 20°C)						
Temperature coefficient of zero signal (TK_0)		± 0.0166						
Relative reversibility error (d_{hy}) ¹⁾		± 0.0166						
Non-linearity (d_{lin}) ¹⁾	% of C_N	± 0.0166						
Creep upon loading (d_{cr}) over 30 min.		± 0.0166						
Input resistance (R_{LC}) (nominal)		389 ± 15						
Output resistance (R_0)	Ω	350 ± 1.5						
Insulation resistance (R_{iso})	GΩ/100 V	> 2						
Reference excitation voltage (U_{ref})	V	5						
Nominal (rated) supply voltage range (B_U)		0.5 to 12						
Nominal (rated) amb. temperature range (B_T)		-10 to +40						
Operating temperature range (B_{tu})	°C	-30 to +70						
Storage temperature range (B_{tl})		-50 to +85						
Reference temperature (t_{ref})		22						
Limit load (E_L)		150						
Breaking load (E_d)	% of E_{max}	200			300			200
Relative perm. vibrational stress (F_{srel}) (oscillation width as per DIN 50100)		70						
Nominal (rated) displacement at maximum capacity (s_{nom}), ± 0.05 mm	mm	0.35	0.4	0.35	0.1	0.2	0.2	0.4
Weight (G), approx.	kg	0.7		1	1.4		1.7	2.2
Degree of protection per EN 60 529 (IEC 529)		IP 68 (test conditions 1 m water column / 100 h)						
Cable length, six-wire configuration		7.6 m as standard						
Material:	Measuring body	stainless steel 1.4545 ²⁾						
	Cable entry	stainless steel / neoprene						
	Cable sheath	PVC						

1) The values for non-linearity (d_{lin}), relative reversibility error (d_{hy}) and temperature coefficient of sensitivity (TK_C) are recommended values. The sum of these values is within the cumulated error limits according to OIML R60.

2) As per EN 10088-1.

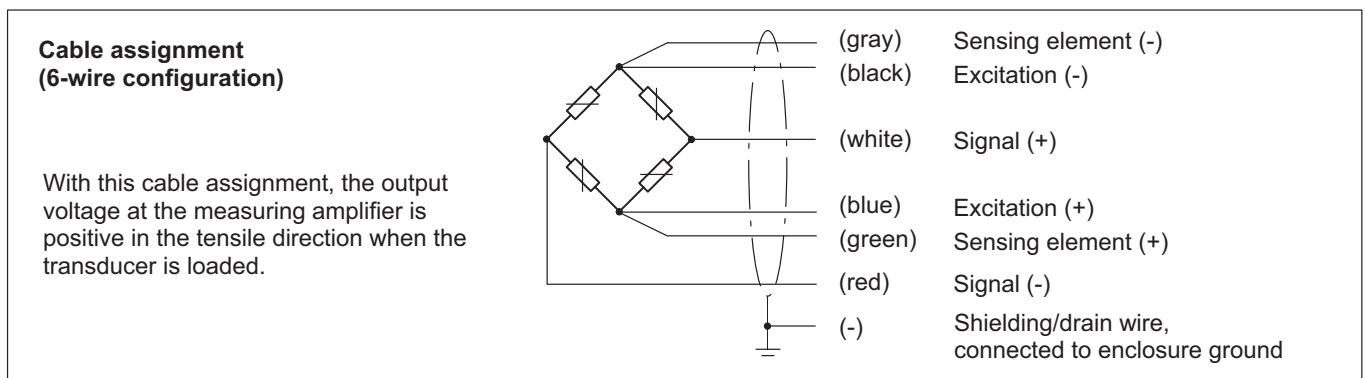

Product numbers (overview)

RSCC load cells

Maximum capacity	Order no.	Maximum capacity	Order no.
50 kg	1-RSCC3/50KG-1	1 t	1-RSCC3/1T-1
100 kg	1-RSCC3/100KG-1	2 t	1-RSCC3/2T-1
200 kg	1-RSCC3/200KG-1	5 t	1-RSCC3/5T-1
500 kg	1-RSCC3/500KG-1		

RSCC load cells, optional versions

Order No.
K-RSCC

Code	Option 1: Design
N	Standard

Code	Option 2: Accuracy class
C3	C3 (OIML)

Code	Option 3: Maximum capacity
50	50 kg
100	100 kg
200	200 kg
500	500 kg
1000	1 t
2000	2 t
5000	5 t

Code	Option 4: Explosion protection
N	No explosion protection
A11/21	IECEX+ATEX Zone 1/21 + FM, intrinsic safe II 2G Ex ia IIC T6/T4 Gb / II 2D Ex ia IIIC T125°C Db*
A12/22	IECEX+ATEX Zone 2/22, not intrinsic safe II 3G Ex ec IIC T6/T4 Gc / II 3D Ex tc IIIC T125°C Dc*

Code	Option 5: Cable length / cable protection system
S7.6	Standard 7.6 m
12	12 m
20	20 m
A7.6	7.6 m with adapter for cable protection system
A12	12 m with adapter for cable protection system
A20	20 m with adapter for cable protection system

K-RSCC - [N] - [C] [3] - [] [] [] [] - [] [] [] [] [] [] - [] [] [] [] [] []

* Including EC-Type Examination Certificate/Certificate of Conformity BVS 13 ATEX X 108 X/IECEX BVS 13.0109 X

RSCC accessories

Accessory	Order no.	Material
Rod end for RSC; 50 kg ... 100kg	1-U1R/200KG/ZGW	Stainless steel
Rod end for RSC; 200 kg ... 1 t	1-U2A/1T/ZGUW	Tempered steel, galvanized; Roller bearing steel; PTFE/bronze corrugated foil
Rod end for RSC; 2 t ... 5 t	1-U2A/5T/ZGUW	

Subject to modifications.
All product descriptions are for general information only. They are not to be understood as a guarantee of quality or durability.

Hottinger Brüel & Kjaer GmbH
Im Tiefen See 45 · 64293 Darmstadt · Germany
Tel. +49 6151 803-0 · Fax +49 6151 803-9100
Email: info@hbm.com · www.hbm.com

measure and predict with confidence

