

Eletta Flow Monitor

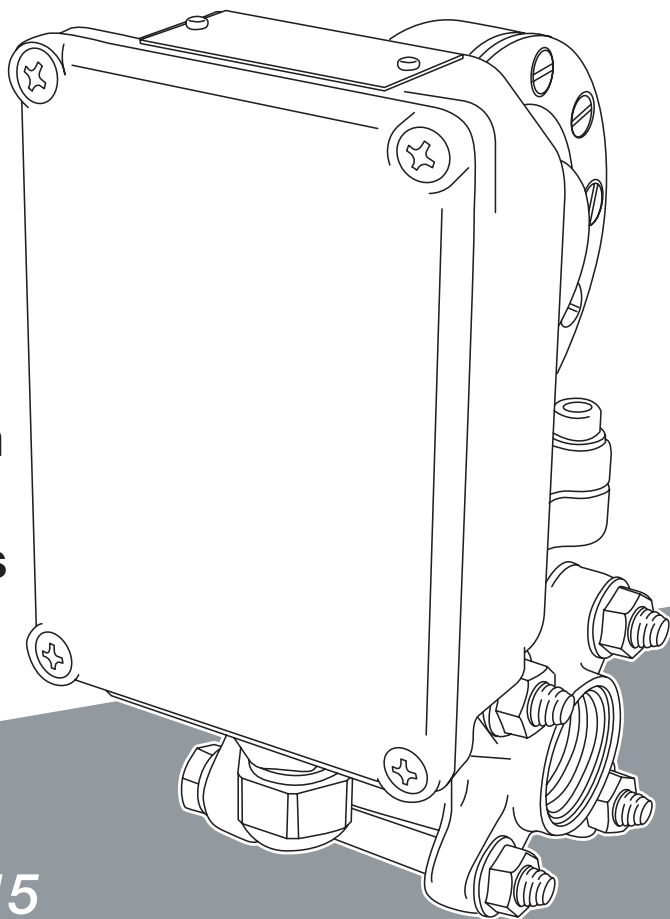

Installation
and
Operations
Manual



*Models
V1 and V15*

ELETTA

— FLOW MONITORS —

Please note that this manual is available as a PDF-file on our website www.eletta.com along with other information such as technical leaflets and application reports.

This gives you the option either to print out the desired publications or watch it on the screen. Of course this also enables you to benefit from the use of modern software.

For instance you can adjust the size of the image to suit your specific need.

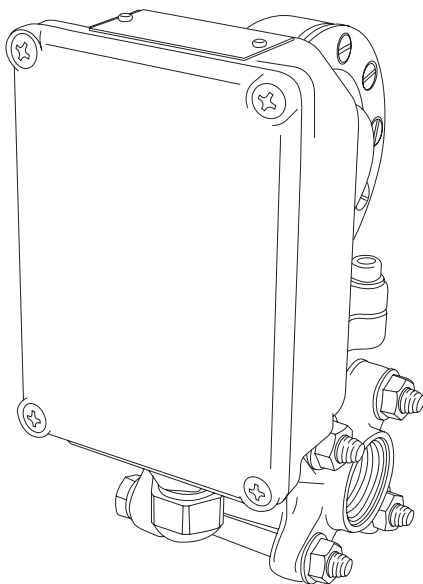

Notice of Proprietary Rights

This manual contains confidential technical data, including trade secrets and proprietary information, which is the property of Eletta Flow AB, Sweden.

Any changes or alterations to downloaded or printed Eletta original literature such as manuals, drawing, etc are not permitted without permission in writing from Eletta Flow AB, Sweden. These data are disclosed to you under the permission that you use it with limits within your company only, not including manufacture or processing uses.

Any other use is strictly prohibited without prior written permission from Eletta Flow AB, Sweden.

Customer Service

Our Customer Service Center is available to answer any of your commercial or technical questions at our normal office hours, 8.00 to 16.30 C.E.T. (8 a.m. to 4:30 p.m. Central European Time) The switchboard is manned 7.00 to 19.00 (7 a.m. to 7 p.m. C.E.T.) Before and after normal office hours on Monday to Friday, you can leave a message to the person at the switchboard and our Customer Service staff will contact you later. Questions and inquiries will be dealt with immediately over the phone or through fax and e-mail. The above hours are not valid at National Holidays or other occasions when production is closed.

Eletta has an International Network of Authorized Distributors, who are able to give you both technical and commercial assistance with our Products. Please see www.eletta.com.

As we have tried to write this manual as carefully and comprehensive as possible from the beginning, we understand that you can still run into problems, which are not clearly described in this manual. In the unlikely event of such an incident, we kindly ask you to make sure that you go through the manual carefully, before contacting our Distributors or Eletta AB in Sweden. This is to save valuable time for any of us involved in the Eletta Products, as it is sometimes easy to overlook a specific sentence in the manual. If you after doing this still are not able to solve the problem, our Customer Service staff, at the below numbers and addresses, are more than happy to help you. You will also find useful information about our Products and organization on our homepage, which you can find at the address below.

This is how you can reach us:

Via Phone: +46 8 603 07 80 (Orders & Inquiries)
+46 8 603 07 70 (Switchboard)

Distributors: See www.eletta.com

Via Mail: Eletta Flow AB
P.O.Box 5084
SE-141 05 Kungens Kurva, SWEDEN

Via e-mail: info@eletta.com

Website: www.eletta.com

Contents

1	General Information	5
	1.1 Description	5
	1.2 Specifications	10
2	Installation	14
	2.1 Unpacking.....	14
	2.2 Procedures before Installation	14
	2.3 Installation of the Pipe Section	15
	2.4 Separate mounting of the Pipe Section and Control Unit	16
	2.5 Installation and changing the Control Unit	18
	2.6 Pressure Drop	20
	2.7 Electrical Installation	22
3	Operation	24
	3.1 Principle of operation, DP-Flow Measurement	24
	3.2 Change of Flow Range	24
	3.3 Change of Flow Direction	26
	3.3.1 Flow Direction Selector (from January 2013).....	26
	3.3.2 Flow Direction Selector (until December 2012)	27
	3.4 Adjustment of switch point	28
4	Trouble shooting	29
	4.1 Verification of Flow.....	29
	4.2 Electrical connections.....	30
	4.3 Spares.....	31
5	Distributors	31
6	Tables	32
	6.1 Measuring Ranges	32
	6.2 Weight and Dimensions	33
7	Spare Parts	34
	7.1 Exploded Drawing V-GL/FA	34
	7.2 Exploded Drawing V-GSS/FSS.....	36

General Information

1.1 Description

The Eletta Flow Monitor is used to control and measure flow of liquids and gases in pipes from size 15 mm to 500 mm (larger pipes as an option). They have been manufactured for over 65 years and are well known for its reliability. They are used where operational safety demands, efficient supervision and rugged installation is needed, all over the world. Eletta Flow AB in Sweden is certified according to ISO9001 and ISO14001.

The Eletta Flow Monitor is based on the proven and dependable differential pressure principle, using interchangeable orifice plates for different measuring ranges. The Flow Monitors are working with two different differential pressure ranges, i.e. 50 – 200 mbar for the V1 and 22 – 550 mbar for the V15, depending on the desired and ordered flow range. The same goes for our models; D2 and D5, S2 and S25 and R2 and R5. Due to the working principle of the instrument, it is of utmost importance that the installation instructions (chapter 2) are followed carefully in order to get the proper function of the instrument.

The Eletta Flow Monitor models V1 and V15 will give you a repeatable switch point of < 2% if installed in the right way. (See chapter 1.2 “Specifications”, for complete information.)

The Instrument consists of two parts mainly i.e. the Pipe Section and the Control Unit. The Pipe Section is the part that is to be mounted in the process pipe and the Control Unit is mounted directly (standard) or remote on/to the Pipe Section. The Control Unit contains the micro switch (SPDT) and the electrical connection terminal block. It also contains the mechanical adjusting dial where you change the setting of the flow alarm tripping point.

The Pipe Sections are available in different process connections with the following standards;

Threaded connections in BSP or NPT from 15 mm (1/2”) to 40 mm (1 1/2”) depending on the chosen material of construction.

Flanged (wafer) connection from DN15 /PN16 (ANSI 1/2”/150 lbs) to DN 500/PN16 (ANSI 20”/150lbs) depending on the chosen material of construction. The DIN-standard flanged units are colored *blue*, the ANSI-standard units are colored *green* (>50 mm < 200 mm) for easy recognition in the field.

The Control Units V1 and V15 are equipped with one, freely adjustable over the whole ordered flow range, micro switch, which can be set for low/high flow alarm.

Product label

Each of our flow monitors wear a product label, see picture below with description.

 Phone +46 (0)8 6030770 www.eletta.com	
Type:	Temp:
Range:	Max Pressure:
Liquid:	Protection Class:
Model:	Std:
No:	CE

- Type: Model type of the flow monitor. For example V15-GL15. Reference to section 1.2 Specifications for a thorough description of available types.
- Temp: The maximum operation temperature allowed for the control unit. Reference to section 1.2 Specifications for a thorough description of available types.
- Range: The flow range for which the flow monitor have been manufactured.
- Max Pressure: The maximum operation pressure allowed for the flow monitor.
- Liquid: The media which the flow monitor have been designated for. Examples: Water, oil etc.
- Protection class: IP -classification (International protection rating), of the control unit.
- Model: The article number of the flow monitor.
- Std: Pipe standard for which the flow monitor is designated. For example: DIN PN16, Dimensions according to DIN and pressure classification according to PN16.
- No: Serial number of the flow monitor. Each of our flow monitor have their own unique id number, which is used for traceability.
- Year of manufacturing.

Ex versions

The Ex versions of flow monitors of type V1 and V15 are designed to be used in explosive atmospheres. The monitors are approved according to the IECEx certification scheme as an intrinsically safe apparatus according to standards IEC 60079-0:2007, IEC 60079-11:2007 and IEC 60079-26:2006.

According to the ATEX directive (94/9/EC) the monitors of type V1 and V15 are considered as “simple apparatuses” according to EN 60079-11:2006. The monitors contain mechanical parts that move slowly and with low power input, incapable of forming hot surfaces or other ignition sources even in cases of rare malfunction. The ATEX directive is not applicable for “simple apparatuses” or for slow moving mechanical parts with low power input. The monitors have been designed and examined as simple apparatus according to EN 60079-0:2009, EN 60079-11:2006, EN 60079-26:2007 and EN 13463-1:2009.

The explosion protection is based on normal atmospheric pressure (0,8-1,1 bar), normal oxygen content (21 % v/v) and minimum ambient temperature -20 °C. For maximum ambient temperature see section 1.2 “Specifications”.

Information in the manual concerning our Ex versions will be marked with:  in the margin.

Ex label

Our Ex approved flow monitors wears an Ex label which defines the explosion protection code and the Intrinsically safe parameters to be used, see picture below with description.

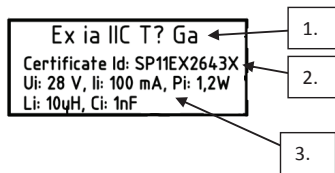

- Explosion protection code. All our Ex versions of the V-series are approved for
 - ia = Intrinsically safe equipment to be used in Zone 0.
 - IIC = Explosion code for flammable and explosive gases; Hydrogen, acetylene, carbon disulphide
 - T? Temperature classification = Indicates the maximum surface temperature of the equipment. Reference to table 5 in section 1.2 Specifications, for available Temperature classes.
 - Ga = Equipment classified for gases in Zone 0.
- Certificate ID: The type examination code of the equipment.
- Intrinsically safe parameters of which the flow monitor should be connected. Reference to 2.7 Electrical installation.

Ex Type ID of our Ex versions

V1 or V15		
Pipe dimension		
Type	DIN PN16	ANSI 150lbs
-FA15-Ex	DN 15	½"
-FA20-Ex	DN 20	¾"
-FA25-Ex	DN 25	1"
-FA32-Ex	DN 32	1 ¼"
-FA40-Ex	DN 40	1 ½"
-FA50-Ex	DN 50	2"
-FA65-Ex	DN 65	2 ½"
-FA80-Ex	DN 80	3"
-FA100-Ex	DN 100	4"
-FA125-Ex	DN 125	5"
-FA150-Ex	DN 150	6"
-FA200-Ex	DN 200	8"
-FA250-Ex	DN 250	10"
-FA300-Ex	DN 300	12"
-FA350-Ex	DN 350	14"
-FA400-Ex	DN 400	16"

Table 1.

V1 or V15		
Pipe dimension		
Type	DIN PN16	ANSI 150lbs
-FSS15-Ex	DN 15	½"
-FSS20-Ex	DN 20	¾"
-FSS25-Ex	DN 25	1"
-FSS32-Ex	DN 32	1 ¼"
-FSS40-Ex	DN 40	1 ½"
-FSS50-Ex	DN 50	2"
-FSS65-Ex	DN 65	2 ½"
-FSS80-Ex	DN 80	3"
-FSS100-Ex	DN 100	4"
-FSS125-Ex	DN 125	5"
-FSS150-Ex	DN 150	6"
-FSS200-Ex	DN 200	8"
-FSS250-Ex	DN 250	10"
-FSS300-Ex	DN 300	12"
-FSS350-Ex	DN 350	14"
-FSS400-Ex	DN 400	16"
-FSS450-Ex	DN 450	18"
-FSS500-Ex	DN 500	20"

Table 2.

V1 or V15	
Type	Pipe dimension
-GSS15-Ex	DN15 (G ½" / NPT ½")
-GSS20-Ex	DN20 (G ¾" / NPT ¾")
-GSS25-Ex	DN25 (G 1" / NPT 1")

Table 3.

V1 or V15	
Type	Pipe dimension
-GL15-Ex	DN15 (G ½" / NPT ½")
-GL20-Ex	DN20 (G ¾" / NPT ¾")
-GL25-Ex	DN25 (G 1" / NPT 1")
-GL40-Ex	DN40 (G 1 ½" / NPT 1 ½")

Table 4.

Ex **Note!:** The control unit may be delivered without a mounted pipe section, in case a unit need to be replaced. The type designation on the product label of the control unit then applies for the complete assembled Flow monitor (control unit and pipe section) according to tables above. An Ex version control unit should only be mounted with a pipe section in accordance to the information on the product label.

Ex Special conditions for safe use

- 1 The blue enclosure and surfaces of the control unit are made of aluminum. This light metal part shall not be subject to impacts or friction in order to avoid sparks.
- 2 The process connection to the Flow monitor must be performed to be sufficiently sealed between the inside and outside of the process connection (IP67).
- 3 To avoid electrostatic charging of the enclosure the internal earth connection must be connected to earth.
- 4 The ambient temperature range for the equipment deviates from the standard range. The temperature class for the equipment depends on the ambient temperature. See table 5 in section 1.2 Specifications, page 13.

1.2 Specifications

The *only* difference between the V1 and V15 is the turn down of the flow range i.e. the V1 has a **1:2** turn down (for example; 50 –100 l/min) and the V15 has a turn down of **1:5** (for example; 40 – 200 l/min).

Repeatability: <+/-2% of actual pre-set tripping flow value.

It is recommended that you always chose the Flow Range of the Flow Monitor so that the normal flow is in the middle of the Monitor Flow Range. Make sure that the expected alarm set points is within the chosen flow range.

For example: If you have a flow of 110 l/min maximum and the normal Flow is at 90 l/min, choose the Eletta Flow Monitor V1 with a Flow Range of 60–120 l/min.

Pressure: Max: 16 bar, (232 PSI), higher test pressure as an option.
Min: A line pressure of appr. 0,7 – 1,0 bar is required for proper operation.

Temperature: Control Unit

-20°C to 90°C, standard

-20°C to 120°C (12°F to 248°F), ambient

Recommendation of choice of rubber material:

Rubber material	Min T °C	Max T °C
Nbr	-20	80
Epdm	-40	100
Fpm	-10	250

Higher **process** temperature possible with remote installation of Control Unit (*separate mounting, see section 2.4*).

Pipe Section:

The pipe sections (GL all sizes and FA ≥ 40 mm ≤ 100 mm) are equipped with spacers holding the orifice plate made of Polyamide plastic (PA) material and they can handle liquid/gas temperature up to 150°C (302°F). For higher process temperature, we recommend to use the stainless steel pipe section, which has no spacers. See spacers p. 9.



Our Ex versions are all equipped with spacers in stainless steel.

Process connection:

DN15 – 40 (½" – 1 ½") for GL-models
 DN15 – 25 (½" – 1") for GSS –models
 DN15 – 400 (½" – 16") for FA-models
 DN15 – 500 (½" – 20") for FSS-models

Control Unit: IP65 (NEMA 4), standard
 Aluminum alloy, alodine and epoxy polyester coated 1
 off cable gland of nickel-plated brass included.

Optional Local Indication:

There is no local readout of the flow or flow set value in the V-series Flow Monitor. However, there is an "Indication window" which can be mounted in the cover of the Control Unit and this can be ordered as an option. This feature indicates roughly how the is which makes it easy to check if there is a flow or not. The "Indication window" is not to be used as an accurate measurement indication of the flow. If you need an accurate and direct reading Flow Monitor, we recommend the S-series Flow Monitor with a large and easy visible 135 mm (5,3") diameter dial. The V-series can be upgraded in the field to an S-series with local indication. Please contact Eletta Flow for advice.

Ex **Note:** Local indication is not available on our Ex versions.

Alarm indication:

On the V-series there is no visible micro switch indication to indicate if the switch is on or off. This feature can be ordered as an option as LED-indication on the side of the Control Unit.

Ex **Note:** LED indication is not available on our Ex versions.

Micro switch spec:

Standard versions - Contact surfaces are silver plated
 Hystereses: ca. 10%
 Voltage: max. 460 VAC
 Current: max. 15 A
 Inductive load: 0,02A @ 230 VDC
 0,03A @ 125 VDC 1A @ 30 VDC Type: SPDT

Ex Ex versions - The contact surfaces of the micro switches are gold plated, suitable for the lower voltage and currents of intrinsically safe circuits

Hystereses: ca. 10%
 Voltage: max. 125 VAC
 Current: max. 1 A
 Inductive load: 0,5 A @ 28 VDC
 Type: SPDT

Material; Diaphragm housing and pipe section:**Type GL:** De-zincificated brass, CW602N, EN12420**Type GSS:** Seaworthy stainless steel 1.4527**Type FA:** Housing: De-zincificated brass, CW602N, EN12420

Pipe section: <DN50 (ANSI 2") Bronze CC491K / EN1982

>DN50 (ANSI 2") Painted cast iron, GG25 / DIN1691

Type FSS: Housing: Seaworthy stainless steel 1.4527 / EN10283

Pipe section: Stainless steel 1.4435

Material

- diaphragm:**
- Textile reinforced Hydrated Nitrile rubber (HNBR), standard on all models except stainless steel.
 - Textile reinforced EPDM rubber, optional for all models.
 - Textile reinforced Fluorinated rubber, FPM, standard in stainless steel models, optional for others.

**Material,
O-rings and
sealings:**

Follows the Diaphragm materials.

Spacer:

(FA and GL): The spacer holds the orifice plate inside the pipe section and for all GL-models and for FA-models ≥ 40 and ≤ 100 . They are made of Polyamide plastic (PA) as a standard. Max. liquid/gas temperature is 120°C (248°F). For other sizes stainless steel 1.4435.



Our Ex versions are all equipped with spacers in stainless steel.

**Intrinsically Safe Data (valid for our Ex versions only):**

The flow monitor is a part of an intrinsically safe circuit according to below data:

Ambient temperature (T_{amb}): Must not exceed the maximum temperature of the medium according to table x below.

Intrinsically safe circuit:

Code for explosions protection: Ex ia IIC T* Ga

* according to table x below

Maximum input voltage (U_i): 28,0VMaximum input current (I_i): 100 mAMaximum input power (P_i): 1,20WMaximum internal capacitance (C_i): 1 nFMaximum internal inductance (L_i): 10 μ H



Relation between medium temp and Temperatur class.

Maximum temperature of the medium through the pipe section of the Flow monitor (°C)	Temperatur class
100	T4
70	T5
60	T6

Table 5.

**CE-
approvals:**

The Eletta Flow Monitors conforms with the EU directive for low voltage no: 72/23/EEC (EN 60 204-1, Part 1). We refer to the certificates issued, which will be sent to you upon request. They can also be found on www.eletta.com.

**PED-
Directive:**

Complies with applicable parts in Pressure Equipment Directive 97/23/EC. Conformity assessment has been performed according to module A. Internal production control combined with module A1. Internal manufacturing checks with monitoring of the final assessment, for category 2. Performed by Inspecta AB, Notified body No. 0409. PED Declaration of conformity will be sent to you upon request and are also available on www.eletta.com.

2.1 Unpacking

We appreciate that you have decided to purchase our Products and we would like to ask you to begin the installation by checking your delivery against the Packing List. Please make sure to check the box for external damages before opening. If you find external damages, which have also led to damages to the Flow Monitor inside, you should contact the forwarder/shipper to claim replacement (or the cost of replacement). Check the Monitors' identification tag against your purchase order to make sure you have got the right articles with the right specifications.

All Monitors are individually packed in plastic bags and put into the box either two by two or individually in each box. The plastic bag is to prevent foreign particles to get inside the Pipe Section, which could prevent proper function of the Flow Monitor after the installation.

The box is made out of recycled environmental friendly material and we kindly ask you to deal with the waste material in a way that will have as little impact to the environment as possible.

2.2 Procedures before Installation

Ex **Note!** Installation and maintenance of Ex versions should be executed according to applicable national laws and regulations. Within EU, directive 1999/92 EC should be considered. EU members within CENELEC should consider the requirements within national standards, based on EN-60079-14 and EN60079-17.

Note!!! Before any installation or maintenance work, disconnect all electrical power! Please check that you are going to mount the Monitor at the lowest point in the piping system if you are measuring liquids and at the highest point if you are measuring gases. Also check if the planned flow direction in the system matches the one indicated on the Monitor. There is a red flow direction arrow on the outside of the pipe section (not the Stainless Steel-models which have a marking engraved on the side). If you find this to mismatch, we refer to section 3.3 "Change of Flow Direction", to adjust the internal flow director in order to match the desired flow direction. Change of the flow direction on our Stainless Steel Pipe Sections (FSS/GSS) is not possible in the field without ordering a new Pipe Section and we kindly ask you to contact your local representative or Eletta Flow AB, Sweden for help.

Check that the pipe section has the right threads or the right flange standard to match your piping or counter flange. If you are using the separate/remote execution i.e. Pipe Section and Control Unit installed in different locations,

please check the plastic hoses for any damages or holes that can prevent proper function. The plastic hoses should not be used in temperatures over 90°C/16 bar (194 °F/232 PSI). If your application temperature exceeds this temperature/pressure, we recommend to use copper or stainless steel tubing, depending on the compatibility to the measured gas or liquid (see section 2.4)



Note: Remote/separate execution is not available on our Ex versions.

2.3 Installation of the Pipe Section

Note!!! Before starting to install the Pipe Section, please make sure that the piping is not under pressure from flow of liquid/gas!

The pipe section can be installed in any desired direction, vertically or horizontally and the direction arrow on the pipe section denote the direction of the flow. It is very important that the pipe section is mounted with the correct direction, as the function of the Flow Monitor otherwise will be prevented. The piping shall be rigid and free from vibrations and hoses connected directly into the Monitors should be avoided as much as possible. If you have weak piping we advise you to use the M6 mounting holes (only on GL-series) on the backside of the pipe section, to fasten the pipe section to a wall or a rigid bracket. The straight runs before and after the Monitor should not be to short, in order to avoid disturbances, which can cause the Monitor to show incorrect values. We recommend giving at least 10-15 diameters upstream and 5 diameters downstream.

(Please see Fig. 1)

Recommended installation of Pipe Section

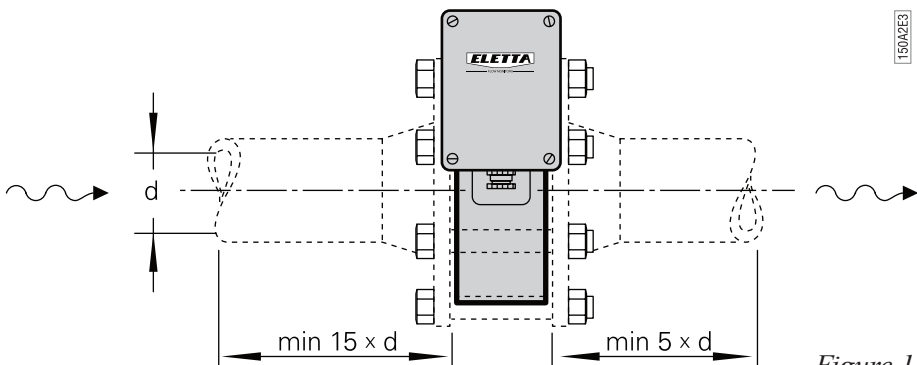

Figure 1

The reasons for this procedure is to achieve a stable flow profile inside the pipe and by doing so, get a true reading. Please be aware of the fact that it is practically impossible to predict when the flow is stable after disturbances in the piping, so this must serve as a guideline only.

The straight runs must be free from valves, bends or in/decreasing diameters. Any of these disturbances must be placed **before** and preferably **after** you start counting the straight runs.

If you are installing the threaded versions, GL and GSS-versions, please make sure that you are not using so called **"tube fittings"**. We have often seen them to have a much smaller inside diameter than the pipe section, even though the size of the thread match. This can create a jet stream of the fluid or gas, which will cause the differential pressure to be too low and you will not get a good or accurate reading.

The following inside diameters apply for the threaded Pipe Sections:

GL- and GSS 15 = **16 mm**

GL- and GSS 20 = **21 mm**

GL- and GSS 25 = **26 mm**

GL-40 = **41 mm**

Make sure that the Control unit, if mounted directly on the pipe section, is placed on top of the pipe section and not under to prevent particles in the fluid to collect in the diaphragm housing. Please consider using a filter in the pipeline if you suspect the fluid to contain particles.

The flanged models, FA and FSS-versions, must be aligned with the counter flange and not placed in stress by tightening the bolts uneven. The flanged models come with a gasket and we recommend using this, as it is dimensioned to suit the installation. Please see to that the packing is properly aligned and not disturbing the flow. It is also of utmost importance that the connecting pipe and flange is of the same diameter (inside) and standard as the pipe section. A mismatch can cause an erratic or incorrect reading of the flow. If needed, please support the Flow Monitors with rigid brackets. There is no problem in attaching the brackets directly to the Flow Monitor (see above), but we recommend mounting them in the pipeline downstream and upstream to avoid unnecessary stress in the installation area.

2.4 Separate mounting of the Pipe Section and the Control Unit

Ex **Note!**: Remote/separate execution is not available as Ex versions.

Sometimes separate mounting of the Pipe Section and the Control Unit is requested due to vibrations, high temperature or lack of space. As the Eletta Flow Monitor is using the differential pressure caused by the orifice plate mounted in the pipeline and directs these two pressures via two individual ports up to the Control Unit, it is also possible to separate the

Monitor into two parts. The pressure is then lead through either plastic hoses or metallic tubing depending on the liquid, pressure and temperature. As a standard, we supply 2x1,75 meter (5.74 feet) of PA plastic, Ø 6 mm (0,23 inch) hoses capable of handling 90°C (194°F) and 16 bar (232 PSI), together with two specially made adapters to be mounted on the Pipe Section and Control Unit respectively. If your application requires metallic tubing (copper or stainless steel) it has to be provided locally. If you are measuring a chemical liquid or gas, check with the supplier which material you should use in your tubing. Please make sure to use only 6 mm tubing in order to suit the tube fittings included in the delivery.

There is no actual limitation in the length of the hoses or tubing, but we recommend placing the units as close as possible to each other, as this will help in troubleshooting and on-site calibration.

Note!!! The hoses/tubings must have the same length to avoid uneven pressure. If you mount valves (not included in delivery) in the pressure hoses/tubing, it will help you to easily shut them off and remove/exchange the Control Unit at full process pressure.

The Mounting of three-way/five-way standard valve (not included in delivery) will allow you to discharge any entrapped air/gas or condense and also provide the possibility to even out the pressure between the plus and minus leg for zero verification.

Please follow the above "Installation of the Pipe Section" after you have mounted the adapter on to the Pipe Section. As you will use hoses/tubing to lead the pressure up to the Control Unit, it is possible to mount the Pipe Section in any direction, vertically or horizontally and with the pressure ports pointing up, down or to the side (*pls. see to section 2.3*).

Separate mounting of Pipe Section and Control Unit GL/FA

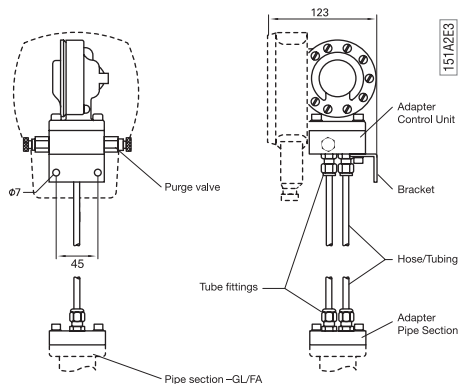

Figure 2

Separate mounting of Pipe Section – GSS/FSS

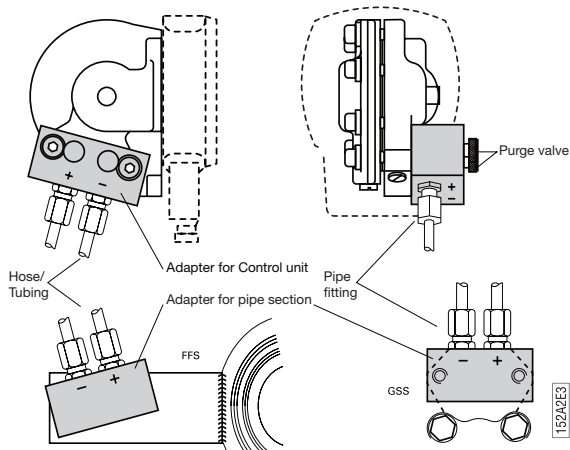

Figure 3

Find a suitable place for the Control Unit to be mounted. Use the supplied bracket to attach it to a wall, pipe or another steady and rigid support. To take advantage of the large and clear dial, the Control Unit should be clearly visible from a distance and easy accessible for maintenance if needed. Please plan this with respect to later mounted piping or other obstacles.

Install the hoses/tubing, commencing with the Pipe Section. Check that you have enough length to cover the distance between the Pipe Section and Control Unit. The Pipe Section adapter has a (+) and (-) marking engraved and the adapter on the Control Unit too. Please make sure to match (+) to (+) and (-) to (-) on the adapters. Press the hose/tube end into the coupling and tighten with care. Proceed to the Control Unit and repeat the above. When you fill up the system for the first time with liquid, please make sure that all entrapped air in the piping between the Pipe Section and Control Unit is removed. The air can otherwise, as it is a compressible media, cause faulty Flow readings.

2.5 Installation and changing of the Control Unit

As all Eletta Flow Monitors are designed in sections to achieve a modular and versatile Flow Monitor, there is a possibility to upgrade/rebuild them and adding other features to your already installed Monitor, by changing the Control Unit or Pipe Section.

Ex

Note!: Equipments which are Ex product are only allowed to be exchanged with other Ex product.

If you, for example, would like to upgrade a V- or S-series with mechanical micro switches to a D-series including analog and/or frequency output, local front display and two independent adjustable relays or the other way around, this is easily done. es

You simply order a Control Unit with the flow range you need.

When you order, you will get the **Control Unit with the diaphragm housing included**. Make sure you order the right material in the diaphragm housing and the soft rubber parts (diaphragm, o-rings and diaphragm lever) and you will get the Control Unit already tested and calibrated and ready to fit onto the Pipe Section, without any on-site adjustments or calibration. All Eletta DP Flow Monitors are working with the same differential pressure within their specific range (*Pls. see section 1.1*).

As an option we have a manifold with shut-off valves, this enables you to dismount the control unit from the pipe-section during full operation.

Start with making sure that there is no pressure in the system. Turn the electric power supply off and then disconnect the cables from the microswitch electric terminal.

On the -GL Pipe Section; loosen the four (4) hexagon screws that hold the diaphragm housing (do **not** remove the blue housing at any time) to the Pipe Section. Replace the flow direction selector (3.3.1 and 3.3.2) if damaged, or if other material is required. *Install the new Control Unit and tighten the four (4) hexagon screws firmly again.*

On the -GSS Pipe Section; loosen the two (2) hexagon screws that hold the diaphragm housing and replace the O-rings to the right material, if necessary. *Install the new Control Unit and tighten the two (2) screws firmly again.*

On the -FA Pipe Section; shut off the two (2) included valves as per above and then untighten the four (4) screws which hold the diaphragm housing. Replace the flow direction selector (3.3.1 and 3.3.2) if damaged, or if other material is required. *Install the new Control Unit and tighten the four (4) screws firmly again. **Do not forget** to open the two (2) shut-off valves again, in order to get a proper function!*

On the -FSS Pipe Section; Loosen the two screws that hold the diaphragm housing and replace the O-rings to the right material, if necessary.

Install the new Control Unit and tighten the two (2) screws firmly again.

Connect the electrical cables according to your new Control Unit's possibilities and for detailed information regarding wiring, please see section 2.7 "Electrical installation".

2.6 Pressure Drop

The Eletta Flow Monitor is a differential pressure measuring device and therefore it creates a certain pressure drop when in function. There are two different types of Pressure Drop's involved, **actual pressure drop** and **permanent pressure drop**. Below we will explain the difference between these two: When the orifice plate mounted in the Eletta Flow Monitor reduces the flow area inside the pipe system, a pressure drop over the orifice is created. This is what we call **actual pressure drop**. *Please refer to chapter 1.1 "Description" for actual pressure drop (differential pressure span).*

The calculation of the flow is using this pressure drop to calculate the actual flow value (*see calculation below*). **The actual pressure drop** is a temporary pressure state and the Eletta Flow Monitors are working within this differential pressure created within the Flow range of the Monitor. When the flow has passed the Monitor, the pressure is then trying to get back to its original pressure and normally after 10 - 15 times the inner diameter of the pipe, the flow becomes linear and fully developed. This is a normalized flow but due to friction losses over our Flow Monitor, the pressure will not be able to reclaim all the energy (*pressure*). This is what we call **permanent pressure drop**.

The **permanent pressure drop** can be calculated approximately by $\Delta\rho_{(ppd)} = \Delta\rho_{(apd)}(1-\beta^2)$, where the symbols represent:

$\Delta\rho_{(ppd)}$ = permanent pressure drop

$\Delta\rho_{(apd)}$ = actual pressure drop for a certain flow

Please see below formula for calculating actual pressure drop.

$\Delta\rho$ = differential pressure flow measurement and

β = **d/D** ratio (ratio between bore and inner diameter of the pipe).

This means that for the normal β range (0.2 - 0.7) a typical permanent pressure loss ranges from 0.96 $\Delta\rho$ and 0.51 $\Delta\rho$ can be expected.

Example:

For the Eletta Flow Monitor V1-GL15 with a flow range of 10 - 20 l/min, the following calculation can be used as an example; bore = 10.20 mm inner diameter = 16 mm This gives $\beta = 10.20/16.00$ which results in $(1-\beta^2) = 0.594 \cdot \Delta\rho$.

Actual pressure drop (differential pressure) at a flow of 15 l/min in the above example = 112,5 mbar (see calculation under fig. 4) Taken the above into consideration, at a flow of 15 l/min, the mentioned Flow Monitor will have an approximate **permanent pressure drop** of: $0,594 \cdot 112,5 \text{ mbar} = 66,82 \text{ mbar}$

The Pressure loss curves in the graph (fig. 4) must serve as a guideline.

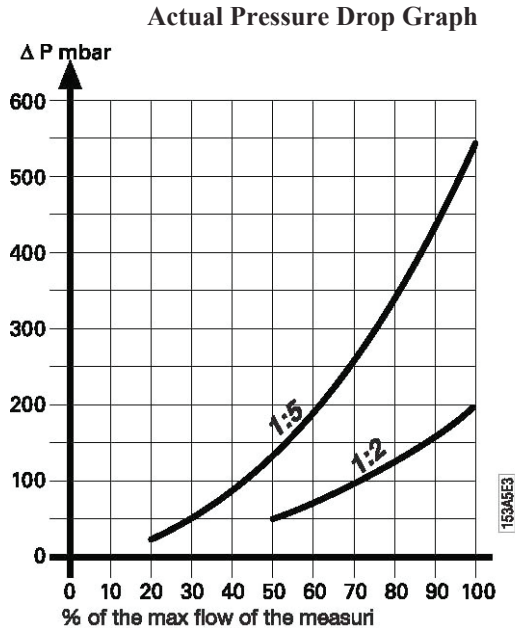

Figure 4

Please use the following formula to calculate Actual Pressure Drop in mbar:

The following formula can be used to calculate the actual pressure drop at a given flow if you have other flow than the example below:

$\Delta\rho \text{ (apd)} = (Q/Q_{\text{max}})^2 \cdot 200$ for turn down ratio of 1:2 and $\Delta\rho = (Q/Q_{\text{max}})^2 \cdot 550$ for turn down ratio of 1:5

Q = actual flow

Q_{\max} = maximum flow of the Flow Monitor (installed orifice plate)

Δp = actual pressure drop in mbar

Example: Eletta Flow Monitor type V1-GL15, flow range 10 - 20 l/min.

Use the formula

$\Delta p_{(\text{apd})} = (Q/Q_{\max})^2 \times 200$ which gives; $\Delta p_{(\text{apd})} = (15/20)^2 = 112,5 \text{ mbar}$

2.7 Electrical Installation

Note!!! An authorized professional person should make all electrical installations and before any circuit is connected/disconnected, make sure that all power is off!

Before you connect any cables, please make sure that you have the right power supply which is within the specifications (see section 1.2 “Specifications”).

All terminal block connections are to be made through the included cable gland PR 22,5/PG 16 and please note that you can have two alternative mountings of the cable gland depending on what side you want to enter with the cables.

Note! If the cable gland is moved make sure that the disposed opening is covered by the screw plug in metal.

Ex

It is allowed to install our Ex versions of the V-series Flow Monitor in an Ex-hazardous area with an intrinsically safe circuit, according to below data:

Ambient temperature (T_{amb}): Must not exceed the maximum temperature of the medium

Explosion protection code: Ex ia IIC T* Ga

* according to table 5, section 1.2 Specifications, page 14

Maximum input voltage (U_i):	28,0V
Maximum input current (I_i):	100 mA
Maximum input power (P_i):	1,20W
Maximum internal capacitance (C_i):	1 nF
Maximum internal inductance (L_i):	10 μ H



To avoid an electric potential difference between pipe system and the flow monitor there are two ring cable shoes supplied with our Ex products. The ring cable shoes may be attached onto the diaphragm housing screws and used as ground terminals to ensure terminal grounding between pipe section and the connecting pipe system. See pictures below.

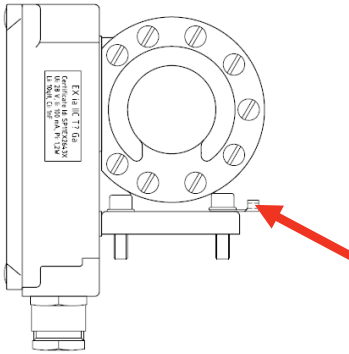

Ground terminals V-GL/FA Ex
version for connection to pipe system

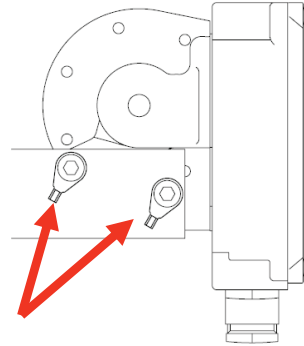

Ground terminals V-SS Ex
version for connection to pipe system

The terminal block connections are described in fig. 6. A grounding screw is to be found at the side of the terminal block.

Wiring diagram

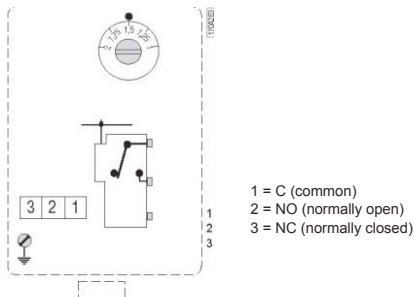

Figure 6

The wiring diagram shows the switching function when the flow is zero or below the setpoint.

3.1 Principle of operation, DP-Flow Measurement

The Eletta Flow Monitor's function is based on the proven and dependable differential pressure principle, using interchangeable sharp-edge orifice plates for different measuring ranges. This is perhaps the oldest and most widely used principle for flow metering, mainly because of its simplicity, its relatively low cost and high volume of research data available for predicting the Flow Monitors behavior. In the Pipe Section, a fixed area flow restriction (the orifice plate) causes a pressure drop, which varies with the flow rate. This pressure drop has a high and a low pressure, which is lead through two channels from each side of the orifice plate, to the Control Unit. By measure the pressure drop allows flow rate measurement by means of a mathematical formula.

A short form of the calculation can be described as $Q = \sqrt{\Delta p}$.

In most Eletta Flow Monitors, the differential pressure is sensed and measured mechanically via a rubber diaphragm and linked to an outside of the process liquid/gas. This mechanism transforms into a movement, which acts mechanically on the pre-adjusted micro switch. All the Eletta Flow Monitors are tested and approved according to the European CE-mark regulations. (*Pls. check www.eletta.com for copy of the certificate.*)

3.2 Change of Flow Range

The Eletta Flow Monitor features an orifice construction that does not require recalibration after replacement and can easily be rebuild in the field to change the flow range to another from the flow rate ordered. This is valid for all Pipe Sections **except the GSS/FSS-models** where you have to order a completely new Pipe Section.

If you need another flow range than ordered originally. The orifice plate inside the pipe section is the only part in the liquid/gas that has to be changed. You can order and change any flow range that suits your specific application, as long as the new flow rate falls within the total possible span for the actual Flow Monitor (*see Flow Rate table in section 6*).

In each case of rebuilding the flow Monitor in the field, we kindly ask you to consult Eletta or your local Distributor for advise of the right orifice plate before ordering.

First empty the piping system so it is un-pressurized and has no flow!

For threaded model -GL:

Untighten the bolts that hold the Pipe Section between the flanges in the piping (Do **not** remove the threaded parts from the piping). Remove only the number of bolts necessary to pull the Monitor from the piping, normally it takes only one bolt from the highest position, to get the Monitor out. Take out one of the spacers that holds the orifice plate. Change the orifice plate to the new ordered orifice plate and remember that you can install it in any direction. Reinstall the spacer that holds the orifice in place inside the Pipe Section. Install the Monitor in the piping system and tighten the bolts firmly to avoid leakage.

For threaded stainless steel model –GSS:

In this model there is no loose replaceable orifice plate and therefore it is necessary to change the complete orifice section with holder, to achieve a new flow range.

Please follow the above instructions for the –GL model for dismantling the whole orifice plate with holder. Remove the Control Unit from the old Pipe Section (orifice section) and install this to the new Pipe Section. Remount the Flow Monitor into the piping system and tighten the bolts firmly.

For flanged model -FA:

Follow the procedure above to loosen the pipe section from the counter flanges in the piping system, but note that the spacers ring is held in place with two screws, which have to be untightened before removal and reinstalled after.

For flanged stainless steel model -FSS:

In this model there is no loose replaceable orifice plate and therefore it is necessary to change the complete pipe unit to achieve a new flow range. Follow the procedure above to loosen the pipe section from the counter flanges in the piping system. Remove the Control Unit from the old Pipe Section (orifice section) and install this to the new Pipe Section. Remount the Flow Monitor into the piping system and tighten the bolts firmly.

Always check that no gaskets will interfere, by misaligning, with the flow when installing the pipe section.

Type plate

When you change the orifice plate in order to get a new flow range, we recommend you to change the identification plate to a plate with the new range marked. This identification plate comes together with the orifice plate when you order an orifice plate separately. Please make sure that your output signals

in the receiving end PLC, display, computer etc., are matched for the new flow range. The micro switch might be necessary to adjust and we refer to the section 3.4 for complete instruction on how to do this.

3.3 Change of Flow Direction

For GL-models, first empty the pipe system so that it is un-pressurized and has no flow!

For FA-models, use the shut-off valves, see section 2.5

At the time of ordering, you must specify in which direction the Flow Monitor shall be mounted i.e. from which side is the flow entering the Pipe Section. (Please refer to fig. 6 below for alternatives.) If, for some reason, the Flow Monitor is ordered with the wrong flow direction, it is possible to change this in the field.

3.3.1 Flow direction Selector (from January 2013)

GL- and FA-models are delivered with a flow direction selector that can be used for both directions.

To change the direction, loosen the four (4) hexagon screw, which hold the diaphragm housing to the Pipe Section. Remove the diaphragm housing and you will see the flow direction selector (it might have attached itself to the bottom side of the diaphragm housing). Replace the flow direction selector in the configuration for your system (see fig. 6).

Please also remember to turn the red arrow mounted on the Pipe Section (-GL and -FA models), to align with the new flow direction.

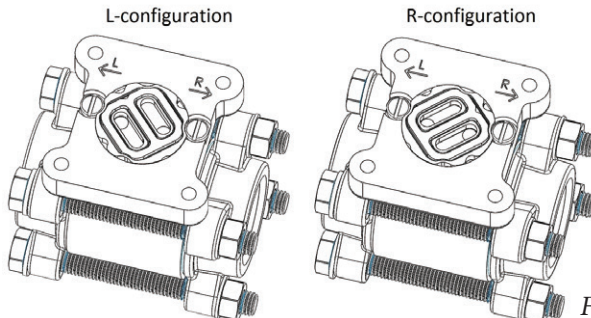

Figure 6

3.3.2 Flow Direction Selector (until December 2012)

For GL and FA models there are two flow direction selectors to choose from, the "R" and the "L" selector.

For flow according to symbol R, use the R Flow Direction selector and the opposite for L.

To change the selector, loosen the four (4) hexagon screws, which hold the diaphragm housing to the Pipe Section. Remove the diaphragm housing and you will see the flow direction selector, which is held in place by two screws. Remove the screws and change the selector. Make sure that the four o-rings are mounted correctly to avoid leakage. Mount the diaphragm housing to the Pipe Section and tighten the four hexagon screws firmly.

Please also remember to turn the red arrow mounted on the Pipe Section (-GL and -FA models), to align with the new flow direction.

For -GSS and -FSS models we refer to section 2.2.

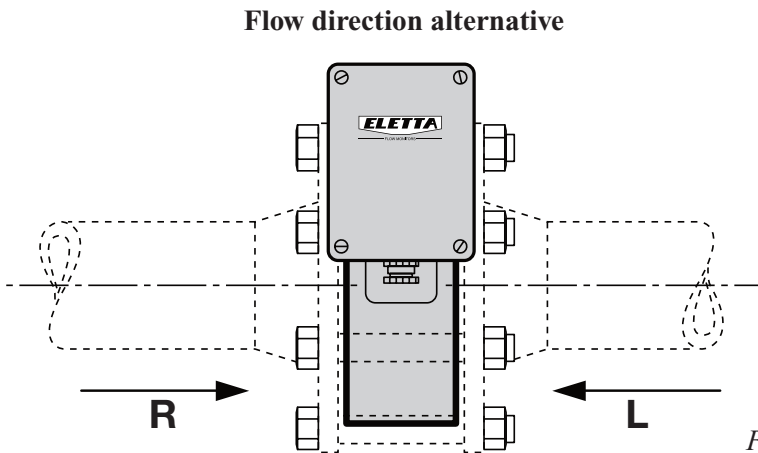

Figure 8

3.4 Adjustment of switch point, V1 and V15

All the Eletta Flow Monitors are tested and calibrated according to the customers' orders before shipping. If the customer does not specify a desired switch point for the flow alarm, the V-series Monitor's micro switch is preset to trip at 50% (decreasing flow) of the ordered max flow value, for example a 10 - 20 l/min flow range would have the switch set to trip at 15 l/min, decreasing flow.

Please note!! We have calibrated each and every Flow Monitor in our flow rig and set the switches according to the Flow values we achieve in the rig under good conditions. We must stress that under actual field conditions, the flow profile can be different from the one in our flow rig depending on valves, hoses, bends or other obstructions and therefore the actual switching can be off from our preset values. There is a possibility to adjust the switch/alarm point in the field by adjusting the micro switches' position mechanically. To readjust, remove the cover and the adjusting dial is then visible at the top. The adjusting dials are marked the same as the scale in the front and this marking can be used to approximately find the right switch/alarm point for the actual application.

Put a screwdriver in the slot of the adjusting dial and gently turn the dial to the desired position. You will find that you by doing this are moving the plate, where the micro switch is mounted, physically. If you have the possibility to check against a flow meter in the system, you will get the best on site adjustment of the switch point. Reinstall the cover and start up the process again.

See fig below for instructions.

Adjusting of high/low flow alarm for V1/V15

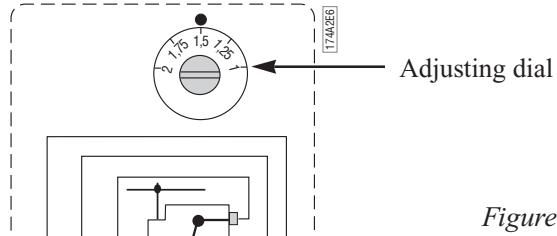

Figure 6B

Trouble shooting

4.1 Verification of flow

We would like to stress the fact that all the Eletta Flow Monitors are calibrated and adjusted individually on water in a specially purpose built calibrated flow rig in our workshop. This means that we have calibrated/adjusted the Monitors under reference conditions with enough straight runs before and after, always the same liquid, temperature, flows and pressure. If you find our Monitors to show another value compared to a reference meter on site, it can well be due to the fact that the reference meter has been calibrated under other reference conditions and that our Monitor have other conditions on site in the actual application, than we used under the calibration prior to shipping. We calibrate all our Monitors against flow and not pressure.

The meter is not giving an alarm:

- Is there any power supply connected?
- Is the Monitor mounted correctly with respect to the flow direction? Please check the arrow on the outside of the pipe section with the actual (true) flow direction for GL- and FA-models, check the flow direction selector inside the monitor. Lift the control unit and check the arrow on this part. Make sure that it is corresponding to the true flow.
- Is there any flow in the pipe? And is it enough to create the needed ΔP ?
- Do you have the right orifice plate for the application? Check the stamped values on the orifice plate. (Pipe section model number and flow)
- If you are using compression couplings into the Monitor inlet, check that the inside diameter is enough to avoid the “nozzle” effect described above in section 2.3 and also check the table for the minimum correct inner diameter in the same section.

Under the above section 3.1 it is described how the Monitor creates the differential pressure. Eletta Flow Monitors work with two different ΔP 's i.e. on the V1 units the ΔP is always maximum 200 mbar and for the V15 units, the ΔP is always maximum 550 mbar. This means that at maximum ΔP the flow is always 100% in any Flow Monitor mounted on any pipe section. This makes it very easy to move one control unit from one pipe to another pipe section on another pipe in order to check the function. It does not matter what size/diameter the pipe section has, as we always work with the same ΔP on every pipe size and corresponding Control Unit.

You can of course also verify the alarm point in the Eletta Flow Monitor versus another flow meter in the system or take the Monitor out and put in a flow test rig, if you have the possibility.

If the above is not the case there is a need to send the Monitor to the Distributor or directly to The Eletta Service department for control.

If you find process liquid/gas coming out of the Control Unit;

Most probably you will find a broken diaphragm lever, the small stainless steel shaft going through a rubber sealing and it is attached to the diaphragm in the end. If you have exposed the Monitor to excessive pressure (over 16 bar/232 PSI standard) or if the process liquid/gas is too aggressive to the rubber in the sealing, it can cause the sealing to break.

When this happens, it nearly always causes a broken circuit board and therefore you will need to replace the whole Control Unit as this is a from the manufacturer calibrated replacement part. Do not replace the diaphragm lever only, as it is in most cases impossible to re-calibrate the V-series Monitor in the field to the right settings.

Please check the identification plate/tag on the Monitor and write down the serial number, flow range and liquid before ordering a new Control Unit from your representative or us. You can then easily replace the broken Control Unit in minutes without any field calibration necessary (*please section 2.5 for details on how to replace a Control Unit*).

If you originally ordered a specially designed Flow Monitor i.e. if it does not follow our standard execution, it must be checked what kind of soft parts (diaphragm and seals) you have installed in the Flow Monitor. There are three different kinds of rubber to order (*see section 1.2 for details*) and we kindly ask you to provide us with the above information in order to help us ship you the right material.

4.2 Electrical connections

Please always see to that you are using the right voltage and current (*see Specification section 1.2*) and that you have connected all the leads in a proper way (*see section 2.7*). If you remove the front dial on the Control Unit of the Monitors it is normally very easy to see, if a component is broken/burned.

If so, please do not try to repair the circuit board yourself. Check the identification plate/tag and write down the serial number, flow range and liquid and order a new Unit from us. It is not possible to order only the circuit board as

the calibration of a new board must be done together with the Control Unit. We will ship you the complete Control Unit with diaphragm housing and you then can easily fit the new Control Unit to your existing Pipe Section with only four (4) screws, (*please see section 2.5 for details*).

4.3 Spares

We are proud to say that our Flow Monitors are well known for their long lifetime and robust construction but inevitably, it is sometimes needed to order spare parts. We refer to section 7 where you can find an exploded drawing showing all replaceable components included in the Flow Monitor.

If you have installed the Eletta V-series Flow Monitor in a very critical application, we recommend you to have a complete identically precalibrated Control Unit on stock, as it will only take removal of four bolts to change this. The Pipe Section consists of no moving parts and all copper alloy/steel material and it is very rare with a break down of this part.

5

Distributors

Eletta has appointed distributors around the world. You find more information about which distributor to contact on our website www.eletta.com or call our customer service.

Phone: +46 8 603 07 80

Tables

6.1 Measuring Ranges

V1		
Dim. DN		lit/min
1/2" DN 15	GL,GSS FA, FSS	0,4 – 0,8
		1 – 2
		1,6 – 3,2
		2 – 4
		2,4 – 4,8
		3,2 – 6,4
		4 – 8
		6 – 12
		8 – 16
		10 – 20
		12 – 24
16 – 32		
3/4" DN 20	GL,GSS FA, FSS	4 – 8
		6 – 12
		8 – 16
		10 – 20
		12 – 24
		16 – 32
		20 – 40
1" DN 25	GL,GSS FA, FSS	8 – 16
		10 – 20
		12 – 24
		16 – 32
		24 – 48
		36 – 72
		40 – 80
1 1/4" DN 32	FA, FSS	50 – 100
		20 – 40
1 1/2" DN 40	GL, FA, FSS	20 – 40
		28 – 56
		40 – 80
		60 – 120
		80 – 160
2" DN 50	FA, FSS	100 – 200
		40 – 80
2 1/2" DN 65	FA, FSS	80 – 120
		80 – 160
		120 – 240
		160 – 320
		240 – 480
		280 – 560
3" DN 80	FA, FSS	120 – 240
		160 – 320
		240 – 480
		320 – 640
		400 – 800
4" DN 100	FA, FSS	160 – 320
		280 – 560
		400 – 800
		600 – 1200
		700 – 1400
5" DN 125	FA, FSS	400 – 800
		600 – 1200
		800 – 1600
		1000 – 2000
6" DN 150	FA, FSS	600 – 1200
		800 – 1600
		1200 – 2400
		1400 – 2800
		1500 – 3000
8" DN 200	FA, FSS	800 – 1600
		1200 – 2400
		1600 – 3200
		2400 – 4800
		2500 – 5000
10" DN 250	FA, FSS	1600 – 3200
		2000 – 4000
		3200 – 6400
		4000 – 8000

V15		
Dim. DN		lit/min
1/2" DN 15	GL,GSS FA, FSS	0,4 – 2
		1 – 5
		2 – 10
		4 – 20
		6 – 30
8 – 40		
3/4" DN 20	GL, GSS FA, FSS	4 – 20
		6 – 30
		8 – 40
		15 – 75
1" DN 25	GL, GSS FA, FSS	6 – 30
		12 – 60
		16 – 80
1 1/4" DN 32	FA, FSS	24 – 120
		30 – 150
1 1/2" DN 40	FA, FSS	8 – 40
		20 – 100
		40 – 200
2" DN 50	FA, FSS	60 – 300
		8 – 40
		20 – 100
2 1/2" DN 65	FA, FSS	40 – 200
		20 – 100
		50 – 250
3" DN 80	FA, FSS	100 – 500
		20 – 100
		40 – 200
		80 – 400
4" DN 100	FA, FSS	160 – 800
		80 – 400
		160 – 800
		240 – 1200
5" DN 125	FA, FSS	240 – 1200
		160 – 800
		250 – 1250
		400 – 2000
6" DN 150	FA, FSS	300 – 1500
		200 – 1000
		400 – 2000
		600 – 3000
8" DN 200	FA, FSS	400 – 2000
		600 – 3000
		1000 – 5000
		1500 – 7500
10" DN 250	FA, FSS	600 – 3000
		1000 – 5000
		1600 – 8000
		2400 – 12000

It is possible to order a lower measuring range than indicated in the table above for each pipe size, but not a higher one.

6.2 Weight and Dimensions

V.-GL						
Type	D	A mm	B mm	C mm	E mm	Weight kg*
-GL15	R 1/2"	75	150	30	80	3,0
-GL20	R 3/4"	75	150	30	80	3,0
-GL25	R 1"	75	150	30	80	3,0
-GL40	R 1 1/2"	85	160	40	90	4,0

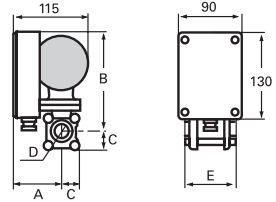

V.-FA					
Type	d mm	D mm	A mm	Width mm	Weight kg*
-FA15	16 (1/2")	53	150	70	4,0
-FA20	22 (3/4")	63	154	70	4,5
-FA25	30 (1")	73	161	70	4,5
-FA32	39 (1 1/4")	84	167	70	5,0
-FA40	43 (1 1/2")	94	172	70	6,0
-FA50	55 (2")	109	180	70	6,0
-FA65	70 (2 1/2")	129	190	70	7,0
-FA80	82 (3")	144	197	70	8,0
-FA100	107 (4")	164	207	70	8,0
-FA125	132 (5")	194	222	70	10,0
-FA150	159 (6")	219	235	70	11,0
-FA200	207 (8")	274	263	70	15,0
-FA250	260 (10")	330	290	70	19,0
-FA300	310 (12")	385	320	70	21,0
-FA350	340 (14")	445	345	70	35,0
-FA400	390 (16")	498	375	70	40,5

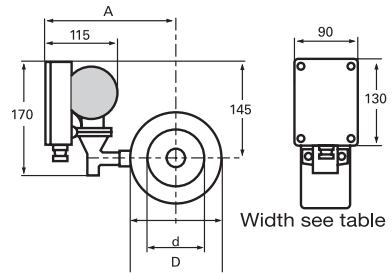

V.-GSS					
Type	D	A mm	B mm	C mm	Weight kg*
-GSS15	R 1/2"	100	130	35	3,0
-GSS20	R 3/4"	100	130	35	3,0
-GSS25	R 1"	100	130	35	3,0

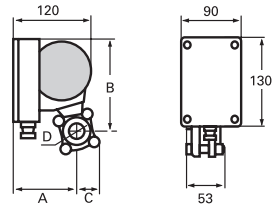

V.-FSS					
Type	d mm	D mm	A mm	Width mm	Weight kg*
-FSS15	16 (1/2")	53	169	15	3,0
-FSS20	22 (3/4")	63	175	15	3,0
-FSS25	30 (1")	73	183	15	3,0
-FSS32	39 (1 1/2")	84	185	15	3,0
-FSS40	43 (1 1/2")	94	190	15	3,0
-FSS50	55 (2")	109	210	15	3,0
-FSS65	70 (2 1/2")	129	220	15	3,5
-FSS80	82 (3")	144	228	15	3,5
-FSS100	107 (4")	164	238	15	4,0
-FSS125	132 (5")	194	253	15	4,5
-FSS150	159 (6")	219	266	15	5,0
-FSS200	207 (8")	274	293	15	6,5
-FSS250	260 (10")	330	320	15	8,0
-FSS300	310 (12")	385	350	15	9,5
-FSS350	340 (14")	445	375	18	14,5
-FSS400	390 (16")	498	405	18	16,5

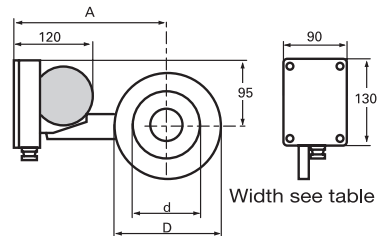

*Approximate weight

3-D models in step format are available on demand.

Exploded drawing

7.1 V-GL/FA

Item	Description	Nos	Item	Description	Nos
1	Cover	1	19	Screw, washer, nut	4
2	Screw	4	20	Pipe body GL	1
3	Terminal block	1	21	O-ring	1
4	Microswitch	1	22	Orifice plate GL	1
5	Adjusting dial	1	23	O-ring	2
6	Casing	1	24	Spacer GL	2
7	Cable gland	1	25	Threaded flange GL	2
8	Lever	1	26	Connecting unit FA	1
9	Diaphragm housing	1	27	O-ring	2
10	Diaphragm	1	28	Shut-off valve	2
11	Diaphragm spring	1	29	Screw	2
12	Diaphragm cover	1	30	O-ring	2
13	Screw	9	31	Pipe body FA	1
14	Screw with washer	4	32	O-ring	1
15	Spring bar	1	33	Orifice plate FA	1
16	O-ring	4	34	Spacer FA	2
17	Screw	2	35	Screw and washer	4
18	Flow direction selector	1			

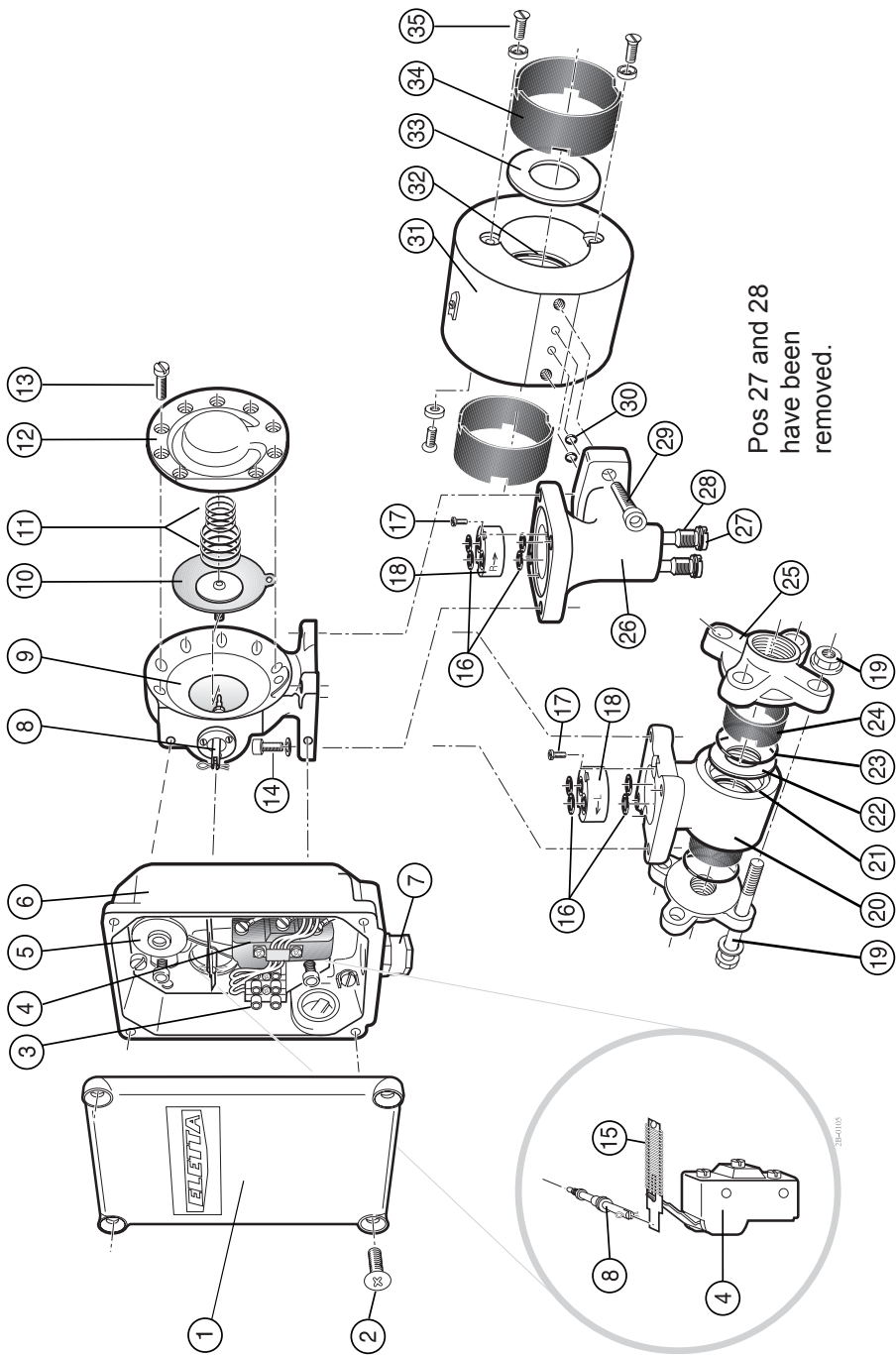

7.2 V-GSS/FSS

Item	Description	Nos	Item	Description	Nos
1	Cover	1	13	Screw with washer	6
2	Screw	4	14	O-ring	2
3	Terminal block	1	15	Spring bar	1
4	Microswitch	1	16	Screw	2
5	Adjusting dial	1	17	Orifice plate/Pipe unit FSS	1
6	Casing	1	18	Orifice plate/Pipe unit GSS	1
7	Cable gland	1	19	Threaded flange GSS	2
8	Lever	1	20	Screw, washer, nut	4
9	Diaphragm housing	1	21	O-ring	2
10	Diaphragm	1	22	Manifold for FSS (Option)	(1)
11	Diaphragm spring	1	23	Shut-off valve (Option)	(2)
12	Diaphragm cover	1			

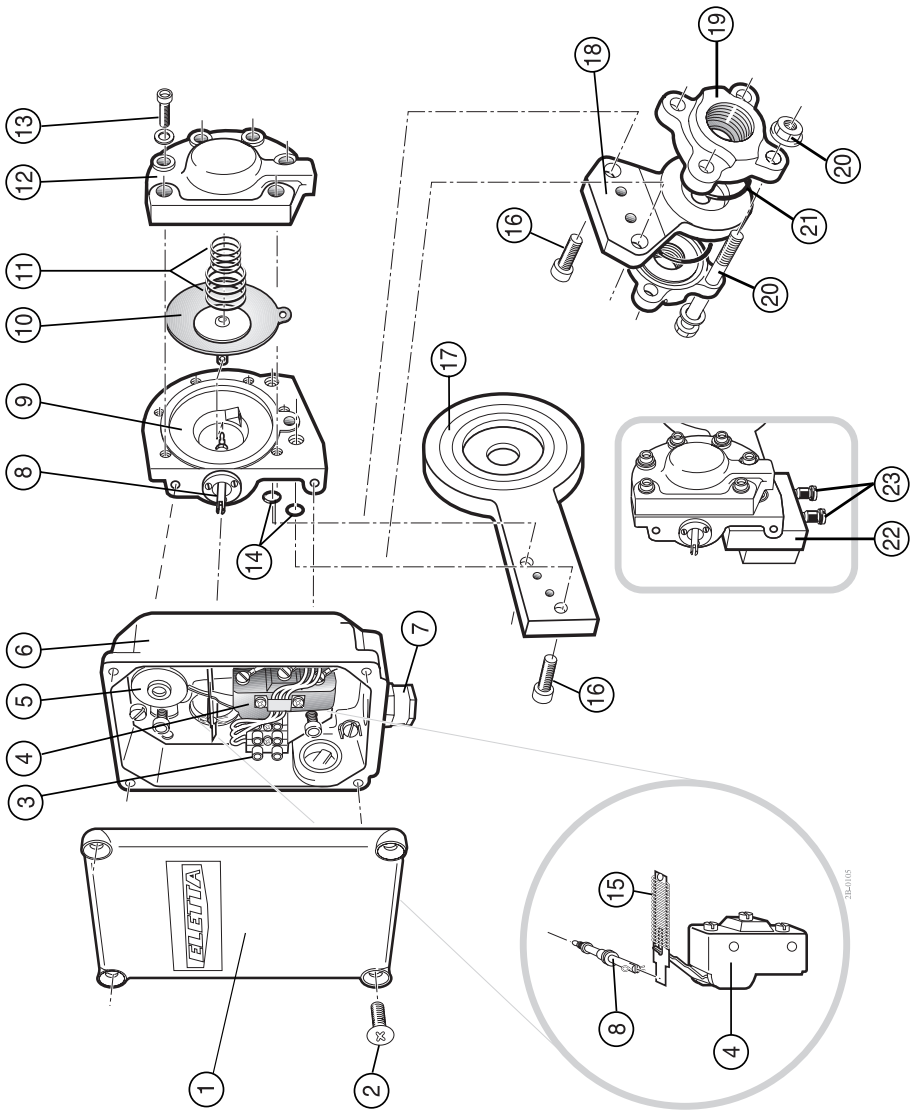



— FLOW MONITORS —